

Helping Customers Innovate, Improve & Grow



### Features

- Reflow Process Compatible
- Surface Mount package
- SC\_CUT Crystal
- Low Profile Compact Package (8.3mm)
- Standard Frequencies: 10; 12.8; 19.2; 20; 26; 30.72 Mhz

### Applications

- Base stations
- Test equipment
- Synthesizers
- Military communication equipment
- Digital Switching

## Performance Specifications

Frequency Stabilities <sup>1</sup> (SC-Cut Crystal-Option - 10 to 40 MHz)					
Parameter	Min	Typical	Max	Units	Condition
vs. operating temperature range (referenced to +25°C)	-10		+10	ppb	-20 to +70°C
	-10		+10	ppb	-40 to +85°C
Initial tolerance	-0.2		+0.2	ppm	at time of shipment, nominal EFC
vs. supply voltage change	-5		+5	ppb	V <sub>s</sub> ±5% static
vs. load change	-5		+5	ppb	Load ±5% static
vs. aging / day	-0.5		+0.5	ppb	≤10 Mhz after 30 days of operation
vs. aging / day	-1		+1	ppb	> 10 Mhz after 30 days of operation
vs. aging / year	-60		+60	ppb	≤ 10 Mhz after 30 days of operation
vs. aging / year	-100		+100	ppb	> 10 Mhz after 30 days of operation
Holdover					
start up time					
Warm-up time			5	minutes	to ±100ppb of final frequency (1 hour reading) @ +25°C

## Performance Specifications

Supply Voltage (Vs)						
Parameter	Min	Typical	Max	Units	Condition	
Supply voltage (standard)	3.135	3.3	3.465	VDC		
	4.75	5.0	5.25	VDC		
Power consumption			3.1	Watts	during warm-up	
			1.5	Watts	steady state @ +25°C	
RF Output						
Signal [standard]	HCMOS					
Load		15		pF		
Signal Level (Vol)			0.4	VDC	with Vs=3.3V and 15pF Load	
Signal Level (Vol)			0.5		with Vs=5.0V & 12V and 15pF Load	
Signal Level (Voh)	2.4			VDC	with Vs=3.3V and 15pF Load	
Signal Level (Voh)	3.5				with Vs=5.0V & 12V and 15pF Load	
Duty Cycle	45		55	%	@ (Voh-Vol)/2	
Rise time			5	ns		
Fall time			5	ns		
Signal	Sine Wave					
Load		50		Ω		
Output Power @3,3V	2	5	8	dBm	50 Ω load	
Putput Power @ 5.0V	5	8	11	dBm	50 Ω load	
Harmonics			-30	dBm	50 Ω load	
Frequency Tuning (EFC)						
Tuning Range	Fixed OCXO; No adjust					Opti- on <sup>5</sup>
	±0.8		±2.4	ppm	with SC cut crystal	
Linearity	10%					
Tuning Slope	Positive					
Control Voltage Range	0.0	1.4	2.8	VDC	with Vs=3.3V	
	0.0	2.0	4.0	VDC	with Vs=5.0V	
modulation						
Reference Voltage Output (Vref)						
Reference Voltage	2.75	2.8	2.85	VDC	with Vs = 3.3 VDC	
	3.92	4.0	4.08	VDC	with Vs = 5.0 VDC	
Additional Parameters						
Phase Noise <sup>3</sup>		-80	-70	dBc/Hz	1 Hz	@ 30.72MHz with SC Cut
		-110	-105	dBc/Hz	10 Hz	
		-138	-130	dBc/Hz	100 Hz	
		-148	-140	dBc/Hz	1 kHz	
		-152	-145	dBc/Hz	10 kHz	
Phase Noise <sup>3</sup>		-90	-80	dBc/Hz	1 Hz	@ 20MHz with SC Cut
		-120	-110	dBc/Hz	10 Hz	
		-140	-135	dBc/Hz	100 Hz	
		-148	-145	dBc/Hz	1 kHz	
		-152	-145	dBc/Hz	10 kHz	
Weight			10	g		
Processing & Packing	Handling & Processing Note					

Absolute Maximum Ratings					
supply voltage (Vs)			5.5	V	with Vs=3.3 & 5.0VDC
Output Load			50	pF	
Operable Temperature Range	-45		+85	°C	
Storage Temperature Range	-45		+85	°C	

## Outline Drawing / Enclosure

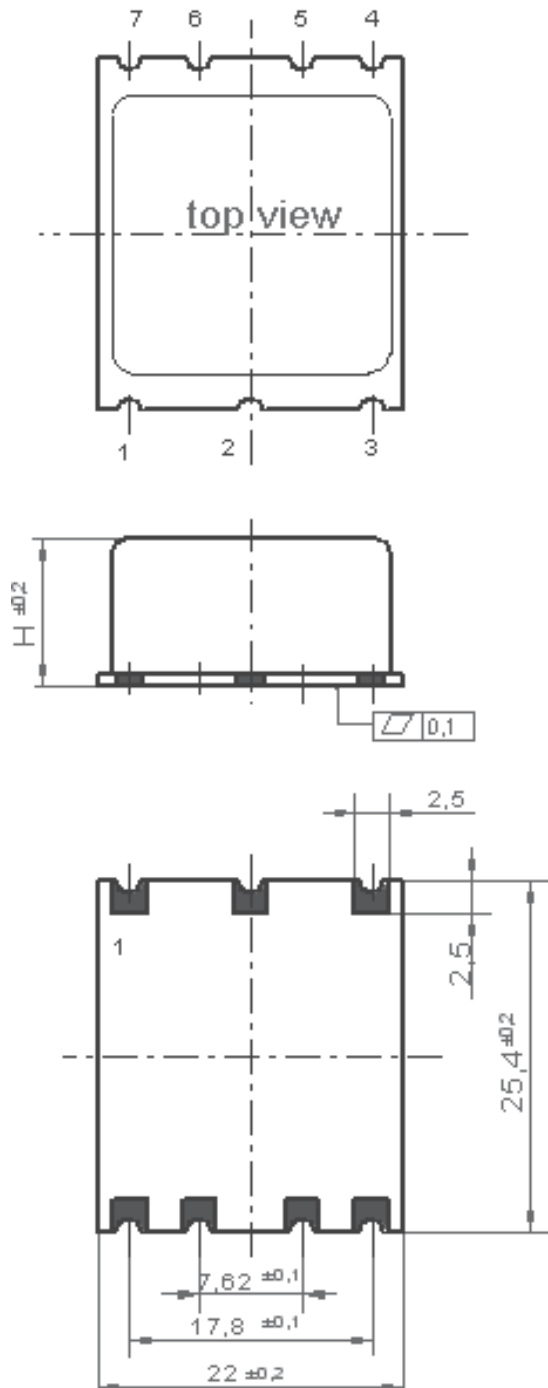

OX-220	
Height "H"	cover material
12.1	plastic
8.5	plastic

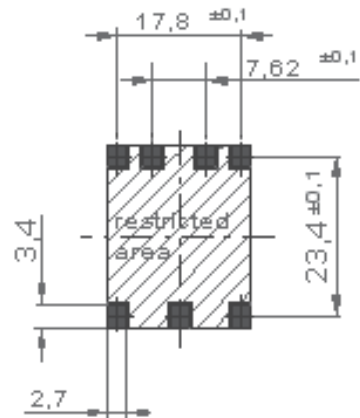

Padvorschlag  
land pattern  
recommendation

Pin Connections	
1	Electronic Frequency Control Input (EFC)
2	Reference Voltage output
3	Supply Voltage Input (Vs)
4	RF Output
5	Oven Alarm
6	N.C or Option (must remain un connected)
7	Ground (Case)

Dimensions in mm

## Standard Shipping Method (OX-220 / OX -221)

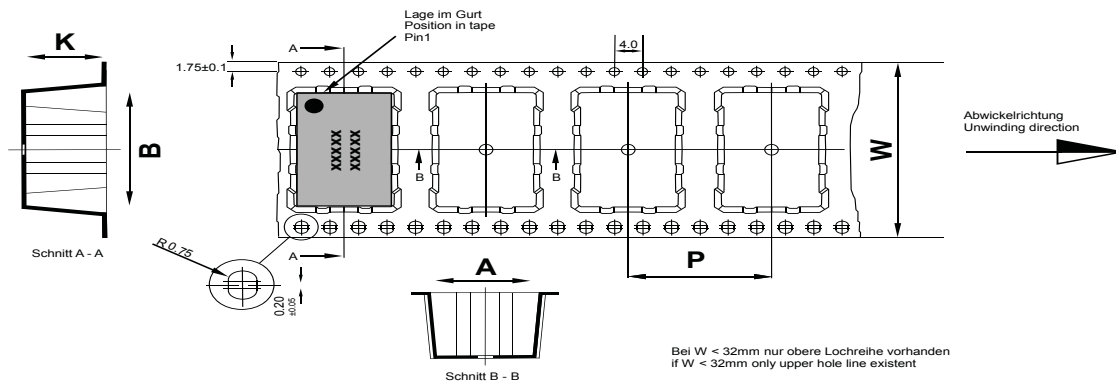

Maßangaben in mm: A, B und K Maße von Bauelement abhängig Fertigungstoleranzen entsprechen der DIN IEC 286-3	Dimension in mm: A, B und K are dependent upon component dimensions production tolerance complying DIN IEC 286-3
--	--

All dimensions in millimeters unless otherwise stated

Enclosure Type	Tape Width W (mm)	Quantity per meter	Quantity per reel	Dimension P
OX-2201 (12.1mm)	44	37.5	175	28
OX-2206 (8.5mm)	44	37.5	250	28

## Recommended Reflow Profile

IPC/JEDEC J-STD-020 (latest revision)  
 Additional Information:  
 This SMD oscillator has been designed for pick and place reflow soldering.  
 SMD oscillators must be on the top side of the PCB during the reflow process.

## Additional Environmental Conditions

Parameter	Description
Rapid temperature changes	MIL-883-1010 Cond B 1000 cycles -55/125C
Vibration	MIL-STD-883 Meth 2007 Cond A 20G 20-2000Hz 4x in each 3axis 4 min
Shock	Mech.Shock MIL-STD-202 Meth 213 Cond.C 100G 6ms 6 shocks in each direction
Solderability	J_STD_002C Cond A, Through hole device/ Cond. B, SMD 255C (diving time 50,5sec.) Dip+Look with 8h damp pre-treatment: solder wetting >95%
Solvent resistance	MIL-STD-883 Meth 2015 Solv. 1,3,4
ESD	HBM JESD22-A114-F Class 1C 10* 1000V
Moisture Sensit.	Level 1 JESD22-A113-B
RoHS compliance	100% RoHS 6 compliant
Washable	non-washable device

**Note:** All temperatures refer to topside of the package, measured on the package body surface.

## Ordering Information

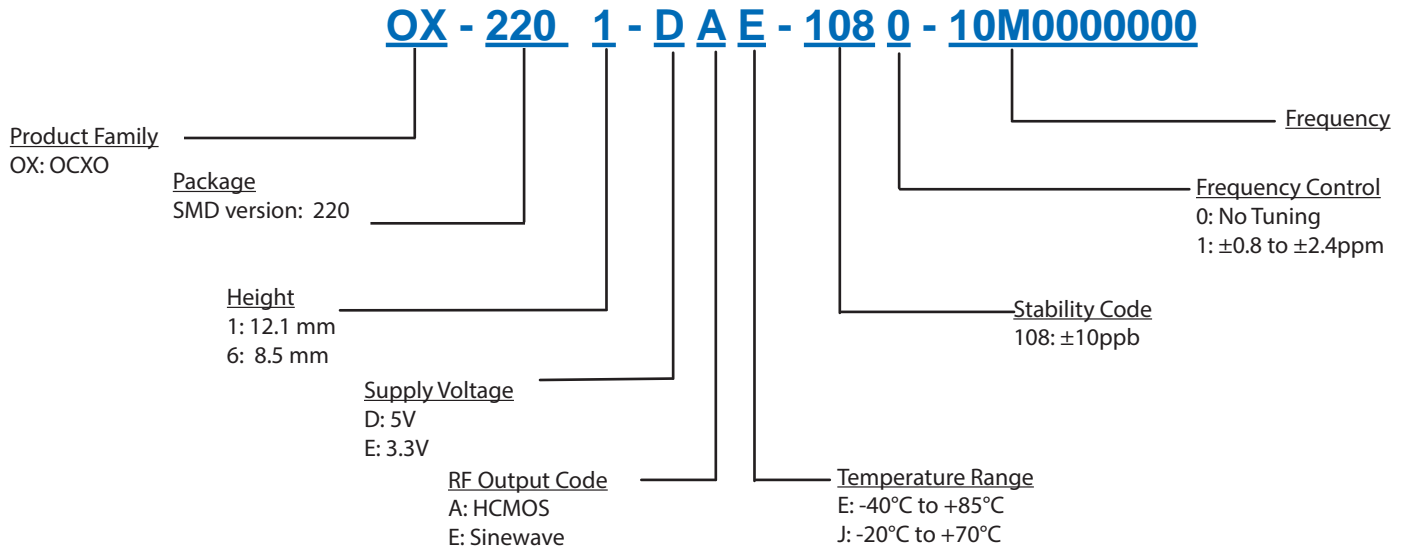

**Notes:**

1. Contact factory for improved stabilities or additional product options. Not all options and codes are available at all frequencies.
2. Unless other stated all values are valid after warm-up time and refer to typical conditions for supply voltage, frequency control voltage, load, temperature (25°C).
3. Phase noise degrades with increasing output frequency.
4. Subject to technical modification.
5. Contact factory for availability.

## For Additional Information, Please Contact

**USA:**

Vectron International  
267 Lowell Road  
Suite 102  
Hudson, NH 03051  
Tel: 1.888.328.7661  
Fax: 1.888.329.8328

**Europe:**

Vectron International  
Landstrasse, D-74924  
Neckarbischofsheim, Germany  
Tel: +49 (0) 7268.801.100  
Fax: +49 (0) 7268.801.282

**Asia:**

Vectron International  
68 Yin Cheng Road(C), 22nd Floor  
One LuJiaZui  
Pudong, Shanghai 200120, China  
Tel: +86 21 6194 6886  
Fax: +86 21 6194 6699

**Disclaimer**

Vectron International reserves the right to make changes to the product(s) and or information contained herein without notice. No liability is assumed as a result of their use or application. No rights under any patent accompany the sale of any such product(s) or information.

Rev 18 Feb 2014