

Monolithic Dual Switching Diode Common Anode

**Lead free product
Halogen-free type**

BAW56GH

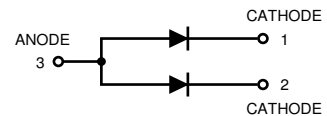
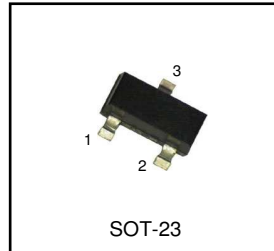

MAXIMUM RATINGS

Rating	Symbol	Value	Unit
Reverse Voltage	V _R	70	Vdc
Forward Current	I _F	200	mAdc
Peak Forward Surge Current	I _{FM} (surge)	500	mAdc

THERMAL CHARACTERISTICS

Characteristic	Symbol	Max.	Unit
Total Device Dissipation FR-5 Board ⁽¹⁾ TA=25°C Derate above 25°C	P _D	225	mW
Thermal Resistance, Junction to Ambient	R _{θJA}	556	°C / W
Total Device Dissipation Alumina Substrate, ⁽²⁾ TA=25°C Derate above 25°C	P _D	300 2.4	mW mW / °C
Thermal Resistance Junction to Ambient	R _{θJA}	417	°C / W
Junction and Storage Temperature	T _J ,T _{STG}	-55 to +150	°C

ELECTRICAL CHARACTERISTICS (TA=25°C unless otherwise noted) (EACH DIODE)

Characteristic	Symbol	Min.	Max.	Unit
----------------	--------	------	------	------

OFF CHARACTERISTICS

Reverse Breakdown Voltage (I _{BR} = 100uAdc)	V _(BR)	70	-	Vdc
Reverse Voltage Leakage Current (V _R =25Vdc, T _J =150°C) (V _R =70Vdc) (V _R =70Vdc, T _J =150°C)	I _R	- - -	30 2.5 50	uAdc
Diode Capacitance (V _R =0, f = 1.0 MHz)	C _D	-	2.0	pF
Forward Voltage (I _F = 1.0 mAdc) (I _F = 10 mAdc) (I _F = 50 mAdc) (I _F = 150 mAdc)	V _F	- - - -	715 855 1000 1250	mVdc
Reverse Recovery Time (I _F = I _R = 10 mAdc, I _R (REC) = 1.0 mAdc) (Figure 1) R _L = 100 Ω	t _{rr}	-	6.0	nS

(1) FR-5=1.0 × 0.75 × 0.062 in.

(2) Alumina = 0.4 × 0.3 × 0.024in. 99.5% alumina.

FIGURE 1. RECOVERY TIME EQUIVALENT TEST CIRCUIT

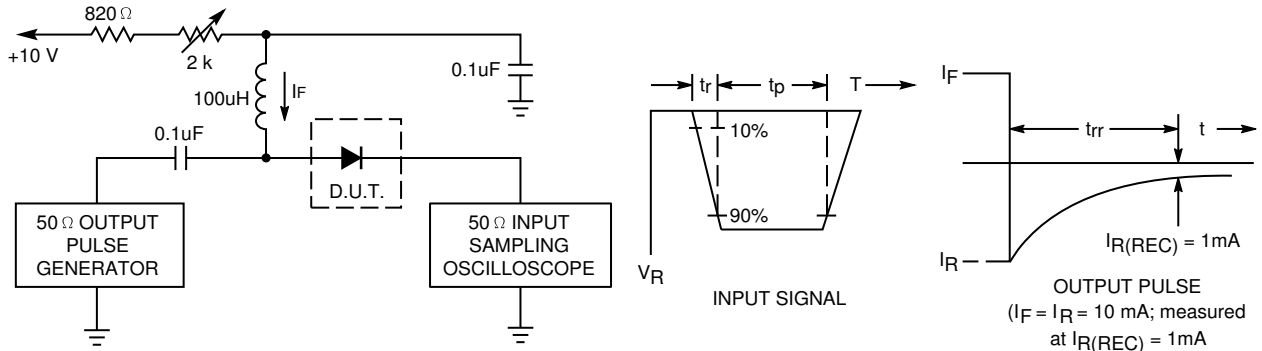

- Notes: 1. A 2.0kΩ variable resistor adjusted for a Forward Current (I_F) of 10mA.
- 2. Input pulse is adjusted so $I_{R(peak)}$ is equal to 10mA.
- 3. $t_p \gg t_{rr}$

FIGURE 2. FORWARD VOLTAGE

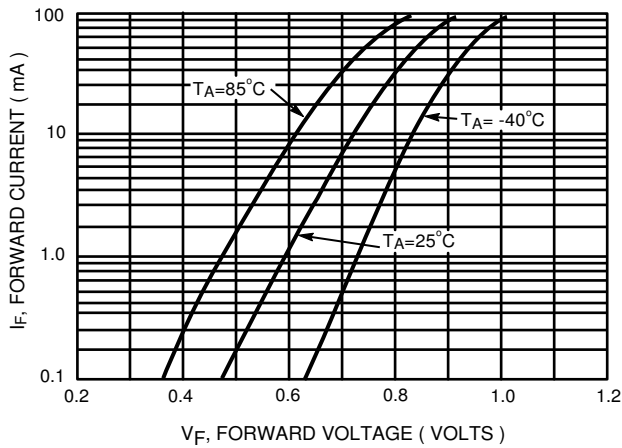

FIGURE 3. LEAKAGE CURRENT

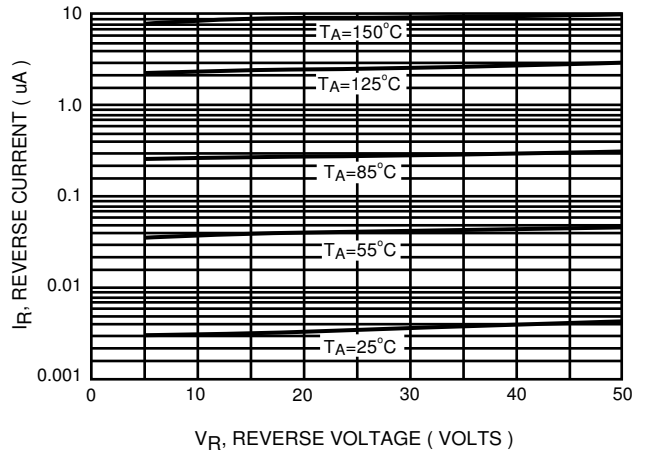
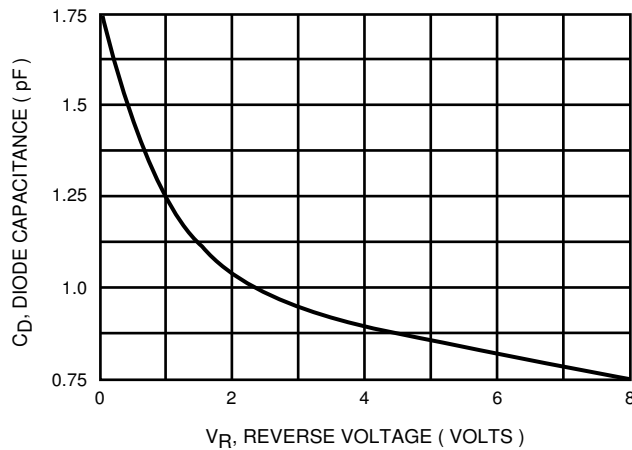

FIGURE 4. CAPACITANCE



CASE DRAWINGS

SOT-23

Unit : mm

