

SCD545H
● FEATURES

- * Halogen-free type
- * Compliance to RoHS product
- * Lead less chip form, no lead damage
- * Low power loss, High efficiency
- * High current capability, low VF
- * Plastic package has Underwriters Laboratory Flammability Classification 94V-0

● APPLICATION

- * Switching mode power supply applications
- * Portable equipment battery applications
- * High frequency rectification
- * DC / DC Converter
- * Telecommunication

● MECHANICAL DATA

Case : Packed with FRP substrate and epoxy underfilled
Terminals : Pure Tin plated (Lead-Free),
 solderable per MIL-STD-750, Method 2026.
Polarity : Laser Cathode band marking
Weight : 0.02 gram

● PACKING

- * **3,000 pieces per 7" (178mm ± 2mm) reel**
- * **4 reels per box**
- * **6 boxes per carton**

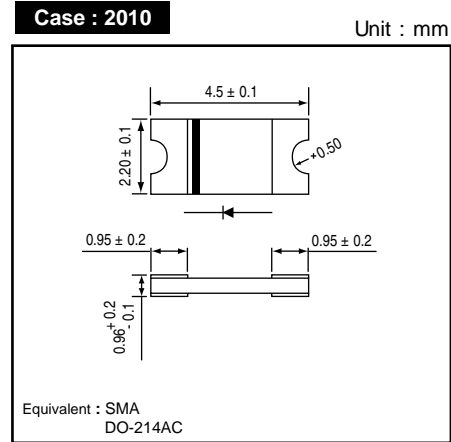
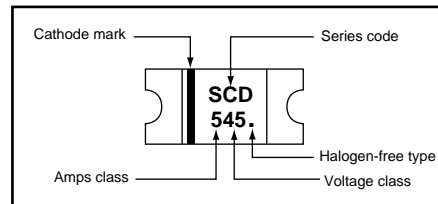
● OUTLINE DIMENSIONS

● MARKING

Absolute Maximum Ratings (Ta = 25 °C)

ITEM	Symbol	Conditions	Rating	Unit
Repetitive peak reverse voltage	VRRM		45	V
Average forward current	IF(AV)	TC = 83 °C	5	A
Peak forward surge current	IFSM	8.3ms single half sine-wave	100	A
Operating junction temperature Range	Tj		125	°C
Storage temperature Range	TSTG		-55 to +150	°C

Electrical characteristics (Ta = 25 °C)

ITEM	Symbol	Conditions	Min.	Typ.	Max.	Unit
Forward voltage (NOTE 1)	VF	IF = 3.0A	-	0.42	-	V
		IF = 5.0A	-	0.48	0.54	
Repetitive peak reverse current	IRRM	VR = Max. VRRM , Ta = 25 °C	-	0.05	0.20	mA
Junction capacitance	Cj	VR = 4V, f = 1.0 MHz	-	210	-	pF
Thermal resistance	Rth(JA)	Junction to ambient (NOTE 2)	-	109	-	°C/W
	Rth(JL)	Junction to case (NOTE 2)	-	29	-	°C/W

NOTES : (1) Pulse test width PW=300usec , 1% duty cycle.
 (2) Mounted on P.C. board with 0.2 x 0.2"(5.0 x5.0mm) copper pad areas.