

# SPECIFICATION FOR APPROVAL

- ( ● ) Preliminary Specification
- (   ) Final Specification

Title	17.1" WXGA TFT LCD
-------	--------------------

BUYER	GENERAL
MODEL	

SUPPLIER	LG.Philips LCD Co., Ltd.
*MODEL	LM171W01
MODEL	B3

\*When you obtain standard approval,  
please use the above model name without suffix

SIGNATURE	DATE
_____/_____ /	_____/_____ /
_____/_____ /	_____/_____ /
_____/_____ /	_____/_____ /

Please return 1 copy for your confirmation with your signature and comments.

SIGNATURE	DATE
S.W.Lee / G.Manager _____	_____ _____
<b>REVIEWED BY</b>	
J.T. Kim / G. Manager _____	_____ _____
<b>PREPARED BY</b>	
Nelson Chung / Engineer _____	_____ _____

**MNT/TV Products Engineering Dept.  
LG. Philips LCD Co., Ltd**

Product Specification

Contents

No	ITEM	Page
	COVER	1
	CONTENTS	2
	RECORD OF REVISIONS	3
1	GENERAL DESCRIPTION	4
2	ABSOLUTE MAXIMUM RATINGS	5
3	ELECTRICAL SPECIFICATIONS	6
3-1	ELECTRICAL CHARACTREISTICS	7
3-2	INTERFACE CONNECTIONS	8
3-3	SIGNAL TIMING SPECIFICATIONS	10
3-4	SIGNAL TIMING WAVEFORMS	11
3-5	COLOR INPUT DATA REFERNECE	12
3-6	POWER SEQUENCE	13
4	OPTICAL SFECIFICATIONS	14
5	MECHANICAL CHARACTERISTICS	18
6	RELIABLITY	21
7	INTERNATIONAL STANDARDS	22
7-1	SAFETY	22
7-2	EMC	22
8	Packing	23
8-1	DESIGNATION OF LOT MARK	23
8-2	Packing FORM	23
9	PRECAUTIONS	24



Product Specification

## 1. General Description

The LM171W01-B3 is a Color Active Matrix Liquid Crystal Display with an integral Cold Cathode Fluorescent Lamp(CCFL) backlight system. The matrix employs a-Si Thin Film Transistor as the active element. It is a transmissive type display operating in the normally white mode. This TFT-LCD has a 17.1 inch diagonally measured active display area with XGA resolution(768 vertical by 1280 horizontal pixel array) Each pixel is divided into Red, Green and Blue sub-pixels or dots which are arranged in vertical stripes. Gray scale or the brightness of the sub-pixel color is determined with a 8-bit gray scale signal for each dot, thus, presenting a palette of more than 16,194,277 colors.

The LM171W01-B3 has been designed to apply the 8Bit Parallel LVDS interface method. The LM171W01-B3 is intended to support displays where high brightness, wide viewing angle, high color saturation, and high color depth are very important.

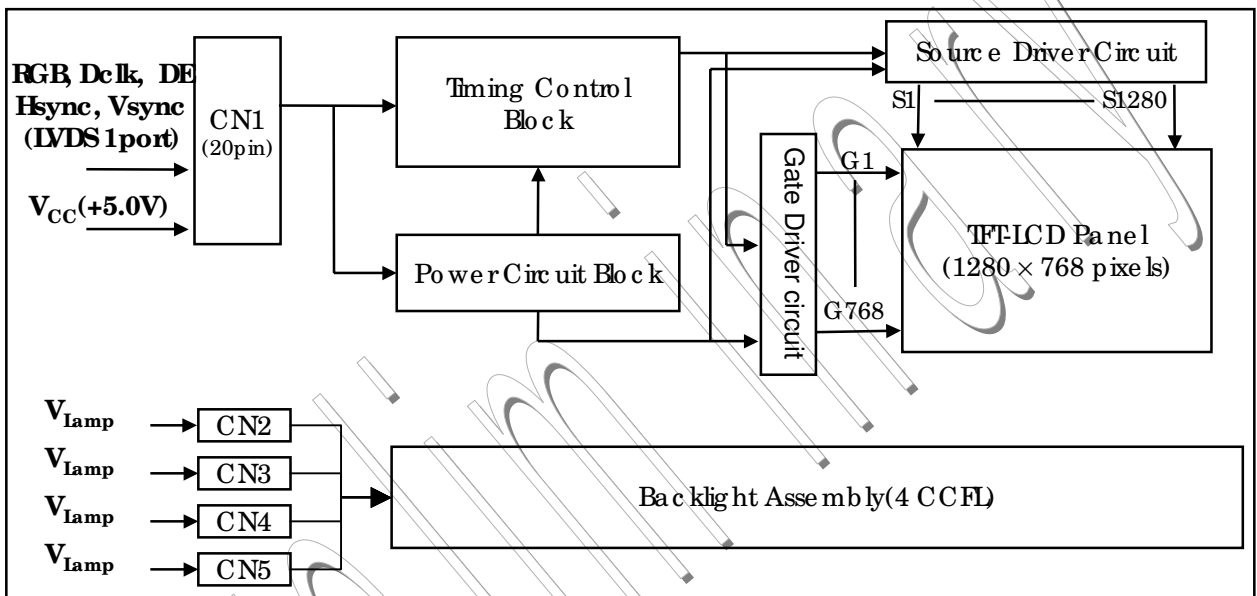

## General Features

Active Screen Size	17.1 inches(43.438cm) diagonal
Outline Dimension	400(H) x 258(V) x 16.8(D)mm (Typ.)/18.5(D)mm(User Connector Area)
Pixel Pitch	0.291mm x 0.291mm
Pixel Format	1280 horiz. By 768 vert. Pixels RGB strip arrangement
Color Depth	16,194,277 Colors (6bit+FRC2bit )
Luminance, White	400 cd/m <sup>2</sup> (Center 1 points typ.)
Power Consumption	Total 22 Watt(Typ.)
Weight	1,900 g (typ.)
Display Operating Mode	Transmissive mode, normally white
Surface Treatment	Hard coating(3H) Anti-glare treatment of the front polarizer,



## Product Specification

### 3. Electrical Specifications

#### 3-1. Electrical Characteristics

The LM171W01-B3 requires two power inputs. One is employed to power the LCD electronics and to drive the TFT array and liquid crystal. The second input which powers the CCFL, is typically generated by an inverter. The inverter is an external unit to the LCD.

**Table 2. ELECTRICAL CHARACTERISTICS**

Parameter	Symbol	Values			Unit	Notes
		Min	Typ	Max		
<b>MODULE :</b>						
Power Supply Input Voltage	Vcc	4.5	5.0	5.5	Vdc	
Power Supply Input Current	Icc	-	272	316	mA	1
Power Consumption	Pc	-	1.4	1.6	Watt	1
<b>LAMP :</b>						
Operating Voltage	VBL	625(9mA)	645(8mA)	765(3mA)	V <sub>RMS</sub>	2
Operating Current	IBL	3.0	8.0	9.0	mA <sub>RMS</sub>	
Established Starting Voltage	Vs					3
at 25 °C				1100	V <sub>RMS</sub>	
at 0 °C				1430	V <sub>RMS</sub>	
Operating Frequency	fBL		60		KHz	4
Discharge Stabilization Time	Ts			3	Min	5
Power Consumption	PBL		20.6	22.7	Watt	6
Life Time		50,000	-	-	Hrs	7

**Note.** The design of the inverter must have specifications for the lamp in LCD Assembly. The performance of the Lamp in LCM, for example life time or brightness, is extremely influenced by the characteristics of the DC-AC Inverter. So all the parameters of an inverter should be carefully designed so as not to produce too much leakage current from high-voltage output of the inverter. When you design or order the inverter, please make sure unwanted lighting caused by the mismatch of the lamp and the inverter (no lighting, flicker, etc) never occurs. When you confirm it, the LCD Assembly should be operated in the same condition as installed in your instrument.

**Note.** Do not attach a conducting tape to lamp connecting wire. If the lamp wire attach to conducting tape, TFT-LCD Module have a low luminance and the inverter has abnormal action because leakage current occurs between lamp wire and conducting tape.

## Product Specification

**Notes:**

1. The specified current and power consumption are under the  $V_{CC}=5.0V$ ,  $25^{\circ}C$ ,  $f_V=60Hz$ ,  $f_{CLK}=65Mhz$  condition whereas mosaic pattern(8 x 6) is displayed and  $f_V$  is the frame frequency.

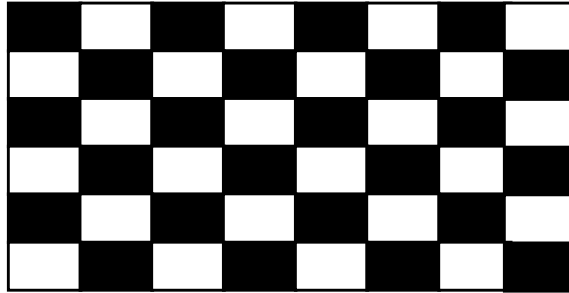

2. Operating voltage is measured at  $25^{\circ}C$ . The variance of the voltage is  $\pm 10\%$ .
3. The output voltage at the transformer in the inverter must be high considering to the loss of the ballast capacitor in the inverter. The voltage above  $V_S$  should be applied to the lamps for more than 1 second for start-up. Otherwise, the lamps may not be turned on.
4. Lamp frequency may produce interface with horizontal synchronous frequency and as a result this may cause beat on the display. Therefore lamp frequency shall be as away possible from the horizontal synchronous frequency and from its harmonics in order to prevent interference.
5. Let's define the brightness of the lamp after being lighted for 5 minutes as 100%.  
 $T_S$  is the time required for the brightness of the center of the lamp to be not less than 95%.  
 The used lamp current is the lamp typical current.
6. The lamp power consumption shown above does not include loss of external inverter at  $25^{\circ}C$ .  
 The used lamp current is the lamp typical current.
7. The life is determined as the time at which luminance of the lamp is 50% compared to that of initial value at the typical lamp current on condition of continuous operating at  $25 \pm 2^{\circ}C$ .

**Note.** The output of the inverter must have symmetrical(negative and positive) voltage waveform and symmetrical current waveform(Asymmetry ratio is less than 10%). Please do not use the inverter which has asymmetrical voltage and asymmetrical current and spike wave.

Requirements for a system inverter design, which is intended to have a better display performance, a better power efficiency and a more reliable lamp.

It shall help increase the lamp lifetime and reduce its leakage current.

- a. The asymmetry rate of the inverter current and voltage waveform should be 10% below;
- b. The distortion rate of the current and voltage waveform should be within  $\sqrt{2} \pm 10\%$ ;
- c. The ideal sine current and voltage waveform shall be symmetric in positive and negative polarities.

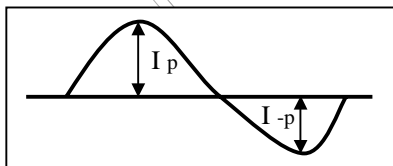

$$* \text{Asymmetry rate} = |I_p - I_{-p}| / I_{rms} * 100\%$$

$$* \text{Distortion rate} = I_p \text{ (or } I_{-p}) / I_{rms}$$

## Product Specification

**3-2. Interface Connections**

- LCD Connector(CN1):D14H-20P-1.25H(Hirose) or equivalent
- Mating Connector : DF14-20S-1.25(Hirose) or equivalent
- LVDS Tx : DS90C385(National Semiconductor) or equivalent

**Table 3-1. MODULE CONNECTOR(CN1) PIN CONFIGURATION**

Pin No	Symbol	Description	Polarity	Output Pin # (LVDS Tx)
1	VDD	Power Supply +5.0V		
2	VDD	Power Supply +5.0V		
3	GND	Power Ground		
4	GND	Power Ground		
5	RXIN0-	LVDS Receiver Signal(-)	Negative	PIN#48
6	RXIN0+	LVDS Receiver Signal(+)	Positive	PIN#47
7	GND	Ground		
8	RXIN1-	LVDS Receiver Signal(-)	Negative	PIN#46
9	RXIN1+	LVDS Receiver Signal(+)	Positive	PIN#45
10	GND	Ground		
11	RXIN2-	LVDS Receiver Signal(-)	Negative	PIN#42
12	RXIN2+	LVDS Receiver Signal(+)	Positive	PIN#41
13	GND	Ground		
14	RXCLK IN-	LVDS Receiver Clock Signal(-)	Negative	PIN#40
15	RXCLK IN+	LVDS Receiver Clock Signal(+)	Positive	PIN#39
16	GND	Ground		
17	RXIN3-	LVDS Receiver Signal(-)	Negative	PIN#38
18	RXIN3+	LVDS Receiver Signal(+)	Positive	PIN#37
19	GND	Ground		
20	NC	Reserved		

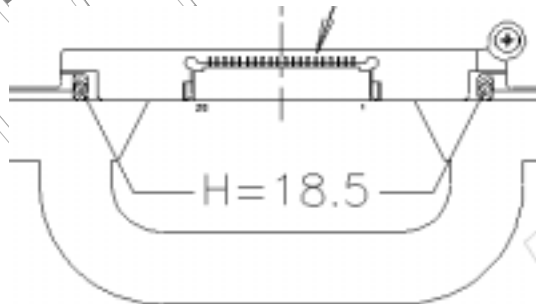

- Note:
1. All GND(ground) pins should be connected together and to Vss which should also be connected to the LCD's metal frame.
  2. All Vcc (power input) pins should be connected together.

Product Specification

**Table 4. BACKLIGHT CONNECTOR PIN CONFIGURATION(CN2,CN3,CN4,CN5)**

Connector (CN2, CN3, CN4, CN5)

Pin	Symbol	Description	Notes
1	HV	Power supply for lamp (high)	1) LCD : BHSR-02VS-1 (JST)
2	LV	Power supply for lamp (Low)	2) System : SM02B-BHSS-1 (JST)

Notes: 1. The high voltage side terminal is colored pink or white.  
The low voltage side terminal is colored pink or black.

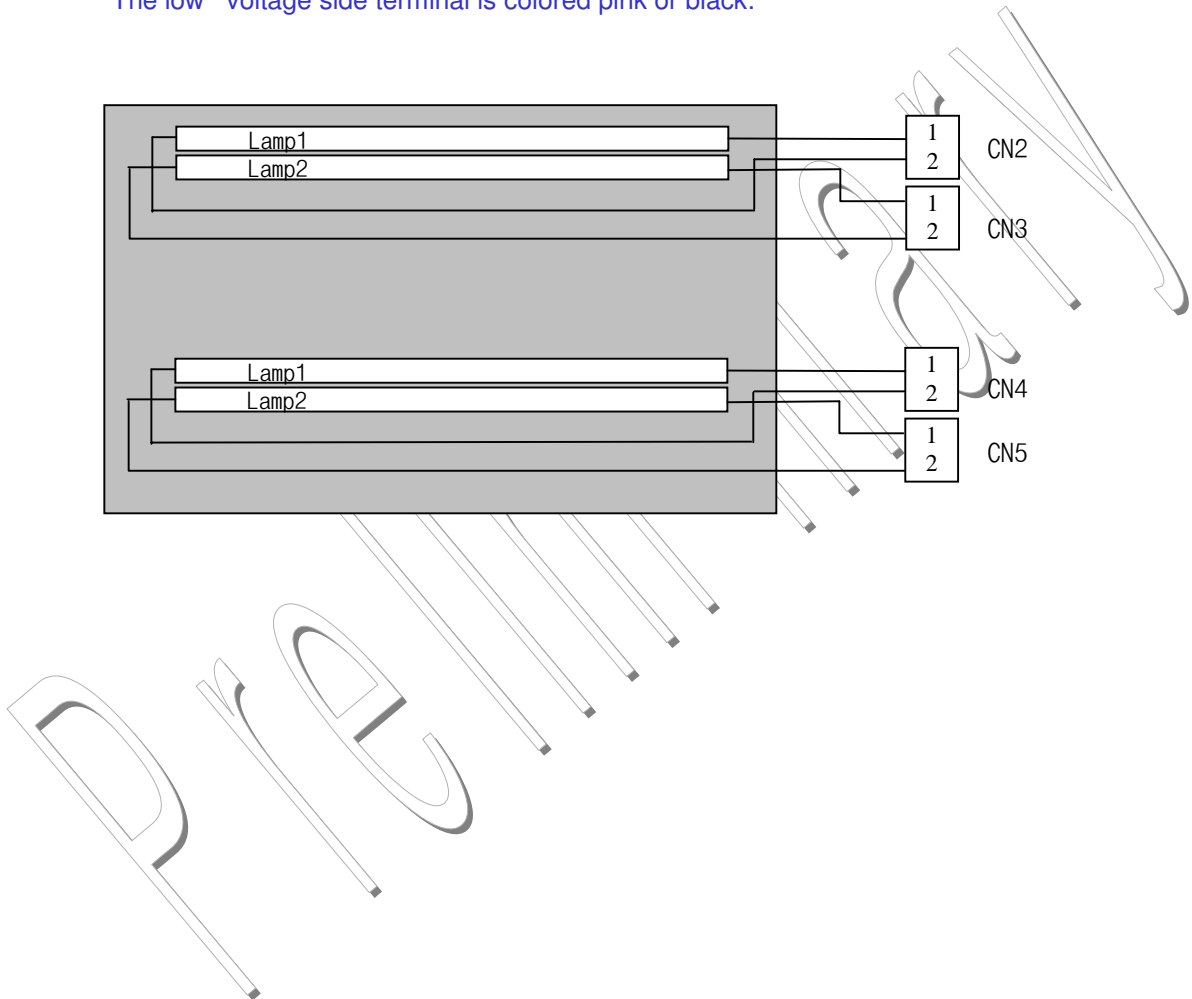

## Product Specification

### 3-3. Signal Timing Specifications

This is the signal timing required at the input of the User connector. All of the interface signal timing should be satisfied with the following specifications for its proper operation.

**Table 5. Timing Table**

ITME	Symbol		Min	Typ	Max	Unit	Notes
DCLK	Frequency	fCLK	-	65	70	MHz	
	Period	tCLK	14.3	15.4		ns	
Hsync	Period	tHP	1312	1320		tCLK	1
	Width-Active	tWH	8	8			
Vsync	Frequency	fvsy	59	60	61	Hz	1
	Period	tVP	772	812		tHP	
	Width-Active	tWV	1	6			
Data Enable	Horizontal back porch	tHBP	8	16		tCLK	for DCLK
	Horizontal front porch	tHFP	16	16			
	Horizontal active Data	tHA	1280	1280	1280		
	Vertical back porch	tVBP	2	35		tHP	
	Vertical front porch	tVFP	1	3			
	Vertical active data	tVA	768	768	768		

1. Hsync Period and Hsync Width-Active should be even number times of tCLK. If the value is odd number times of tCLK, display control signal can be asynchronous. This LCM operates in Hsync., Vsync. and Data Enable mode. If Vsync. signal is abnormally applied to the user connector of LCM, The display of LCM is black. While the frequency of Vsync.is 40~85Hz, the LCM can be normally displayed.

Product Specification

3-4. Signal Timing Waveforms

Condition :  $V_{\text{LOGIC}} = 3.3\text{V}$

DCLK, Data Enable, Hsync, Vsync, data

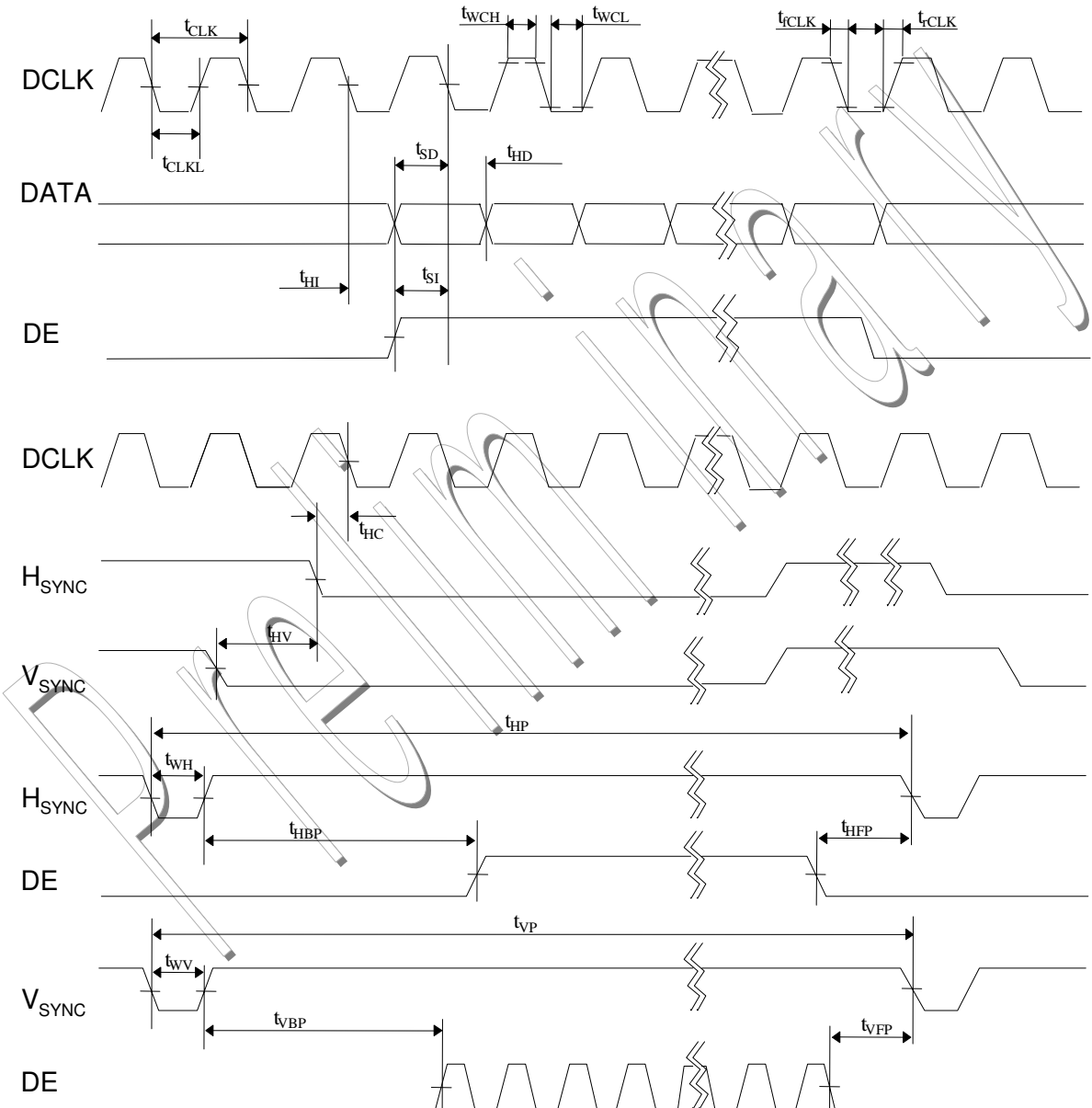
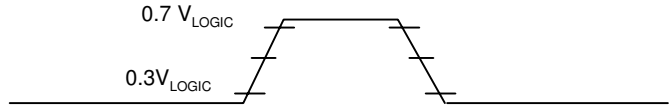

## Product Specification

**3-5. Color Input Data Reference**

The brightness of each primary color (red, green and blue) is based on the 8-bit gray scale data input for the color ; the higher the binary input, the brighter the color. The table below provides a reference for color versus data input.

**Table 6. COLOR DATA REFERENCE**

Color		Input Color Data																							
		RED								GREEN								BLUE							
		MSB				LSB				MSB				LSB				MSB				LSB			
		R7	R6	R5	R4	R3	R2	R1	R0	G7	G6	G5	G4	G3	G2	G1	G0	B7	B6	B5	B4	B3	B2	B1	B0
Basic Color	Black	0	0	0	0	0	0	0	0	0	0	0	0	0	0	0	0	0	0	0	0	0	0	0	0
	Red (255)	1	1	1	1	1	1	1	1	0	0	0	0	0	0	0	0	0	0	0	0	0	0	0	0
	Green (255)	0	0	0	0	0	0	0	0	1	1	1	1	1	1	1	1	0	0	0	0	0	0	0	0
	Blue (255)	0	0	0	0	0	0	0	0	0	0	0	0	0	0	0	0	1	1	1	1	1	1	1	1
	Cyan	0	0	0	0	0	0	0	0	1	1	1	1	1	1	1	1	1	1	1	1	1	1	1	1
	Magenta	1	1	1	1	1	1	1	1	0	0	0	0	0	0	0	0	1	1	1	1	1	1	1	1
	Yellow	1	1	1	1	1	1	1	1	1	1	1	1	1	1	1	1	0	0	0	0	0	0	0	0
	White	1	1	1	1	1	1	1	1	1	1	1	1	1	1	1	1	1	1	1	1	1	1	1	1
RED	RED (000)	0	0	0	0	0	0	0	0	0	0	0	0	0	0	0	0	0	0	0	0	0	0	0	0
	RED (001)	0	0	0	0	0	0	0	1	0	0	0	0	0	0	0	0	0	0	0	0	0	0	0	0
	...	...	...	...	...	...	...	...	...	...	...	...	...	...	...	...	...	...	...	...	...	...	...	...	
	RED (254)	1	1	1	1	1	1	1	0	0	0	0	0	0	0	0	0	0	0	0	0	0	0	0	0
	RED (255)	1	1	1	1	1	1	1	1	0	0	0	0	0	0	0	0	0	0	0	0	0	0	0	0
GREEN	GREEN (000)	0	0	0	0	0	0	0	0	0	0	0	0	0	0	0	0	0	0	0	0	0	0	0	0
	GREEN (001)	0	0	0	0	0	0	0	0	0	0	0	0	0	0	0	1	0	0	0	0	0	0	0	0
	...	...	...	...	...	...	...	...	...	...	...	...	...	...	...	...	...	...	...	...	...	...	...	...	
	GREEN (254)	0	0	0	0	0	0	0	0	1	1	1	1	1	1	1	0	0	0	0	0	0	0	0	0
	GREEN (255)	0	0	0	0	0	0	0	0	1	1	1	1	1	1	1	1	0	0	0	0	0	0	0	0
BLUE	BLUE (000)	0	0	0	0	0	0	0	0	0	0	0	0	0	0	0	0	0	0	0	0	0	0	0	0
	BLUE (001)	0	0	0	0	0	0	0	0	0	0	0	0	0	0	0	0	0	0	0	0	0	0	0	1
	...	...	...	...	...	...	...	...	...	...	...	...	...	...	...	...	...	...	...	...	...	...	...	...	
	BLUE (254)	0	0	0	0	0	0	0	0	0	0	0	0	0	0	0	0	1	1	1	1	1	1	1	0
	BLUE (255)	0	0	0	0	0	0	0	0	0	0	0	0	0	0	0	0	1	1	1	1	1	1	1	1



Product Specification

4. Optical Specification

Optical characteristics are determined after the unit has been 'ON' and stable for approximately 30 minutes in a dark environment at 25 °C. The values specified are at an approximate distance 50cm from the LCD surface at a viewing angle of  $\Phi$  and  $\theta$  equal to 0 °.

FIG. 1 presents additional information concerning the measurement equipment and method.

FIG. 1 Optical Characteristic Measurement Equipment and Method

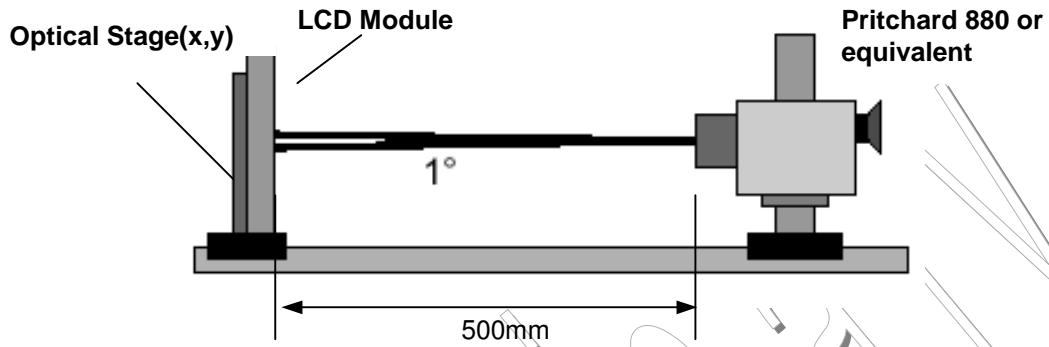

Table 7. OPTICAL CHARACTERISTICS

Ta=25 °C, V<sub>CC</sub>=5.0V, fv=60Hz  
Dclk=65MHz, I<sub>BL</sub>=8mA

Parameter	Symbol	Values			Units	Notes
		Min	Typ	MAx		
Contrast Ratio	CR	300	350			1
Surface Luminance, white	L <sub>WH</sub>	330	400		cd/m <sup>2</sup>	2
Luminance Variation	$\delta_{WHITE}$			1.3		3
Response Time	Tr		25	30	ms	4
Rise Time	Tr <sub>R</sub>		7	10		
Decay Time	Tr <sub>D</sub>		18	20		
Color Coordinates						
RED	RX	0.587	0.617	0.647		
RY		0.304	0.334	0.364		
GREEN	GX	0.253	0.283	0.313		
GY		0.560	0.590	0.620		
BLUE	BX	0.113	0.143	0.173		
BY		0.056	0.086	0.116		
WHITE	WX	0.254	0.284	0.314		
WY		0.265	0.295	0.325		
Viewing Angle						
x axis, right( $\phi=0^\circ$ )	$\theta_r$	55	60		degree	5
x axis, left ( $\phi=180^\circ$ )	$\theta_l$	55	60			
y axis, up ( $\phi=90^\circ$ )	$\theta_u$	40	45			
y axis, down ( $\phi=270^\circ$ )	$\theta_d$	40	45			
Gray Scale						6

Product Specification

Notes 1. Contrast Ratio(CR) is defined mathematically as :  

$$\text{Contrast Ratio} = \frac{\text{Surface Luminance with all white pixels}}{\text{Surface Luminance with all black pixels}}$$

2. Surface luminance is luminance value at point 1 across the LCD surface 50cm from the surface with all pixels displaying white. For more information see FIG 2.  
 When  $I_{BL}=8mA$ ,  $L_{WH}=330cd/m^2(\text{Min.})$   $400cd/m^2(\text{Typ.})$

$$L_{WH} = L_{on1}$$

Where  $L_{on1}$  is the luminance with all pixels displaying white at center 1 location.

3. The variation in surface luminance,  $\delta_{WHITE}$  is defined as :

$$\delta_{WHITE} = \text{Maximum}(L_{on1}, L_{on2}, \dots, L_{on5}) / \text{Minimum}(L_{on1}, L_{on2}, \dots, L_{on5})$$

4. Response time is the time required for the display to transition from to black(Rise Time,  $Tr_R$ ) and from black to white(Decay Time,  $Tr_D$ ). For additional information see FIG 3.

5. Viewing angle is the angle at which the contrast ratio is greater than 10. The angles are determined for the horizontal or x axis and the vertical or y axis with respect to the z axis which is normal to the LCD surface. For more information see FIG 4.

6. Gray scale specification

Gray Level	Luminance [%] (Typ)
L0	0.22
L15	0.32
L31	0.68
L47	1.65
L63	3.36
L79	5.87
L95	9.1
L111	13.3
L127	18.2
L143	24.4
L159	31.9
L175	40.8
L191	51.5
L207	63.2
L223	76.1
L239	89.8
L255	100

Product Specification

**FIG. 2 Luminance**

<measuring point for surface luminance & measuring point for luminance variation>

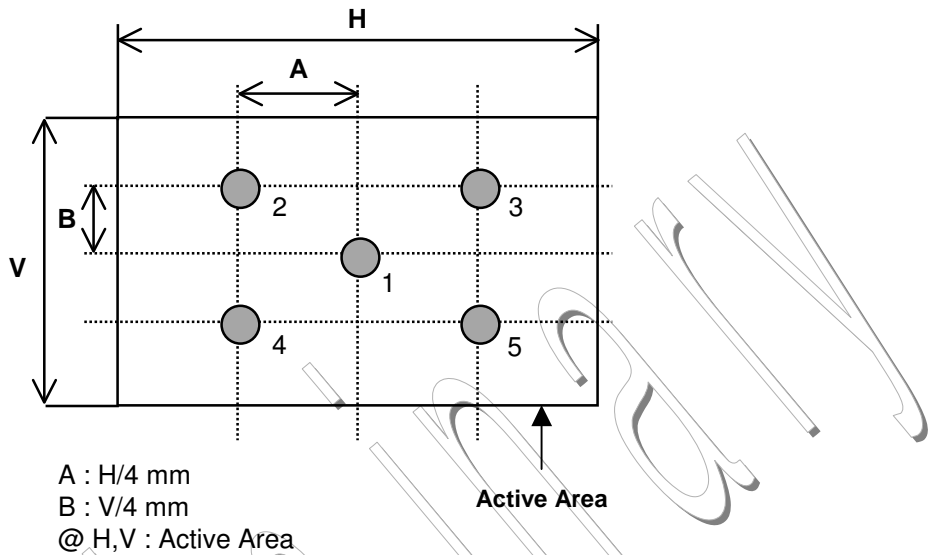

**FIG. 3 Response Time**

The response time is defined as the following figure and shall be measured by switching the input signal for "black" and "white".

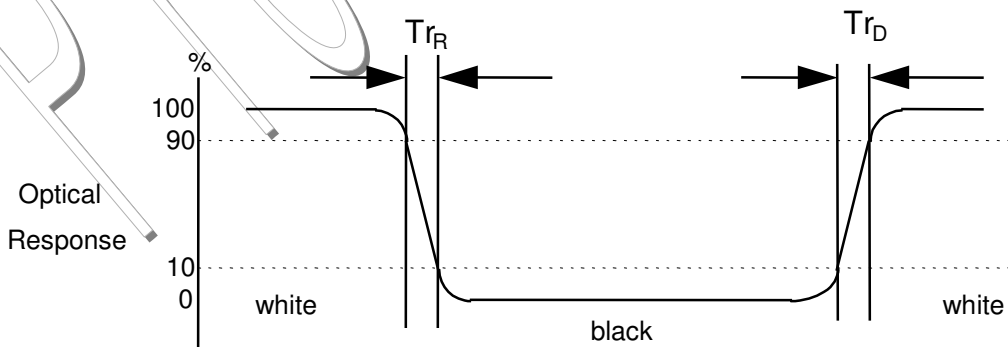

Product Specification

FIG. 4 Viewing angle

<Dimension of viewing angle range>

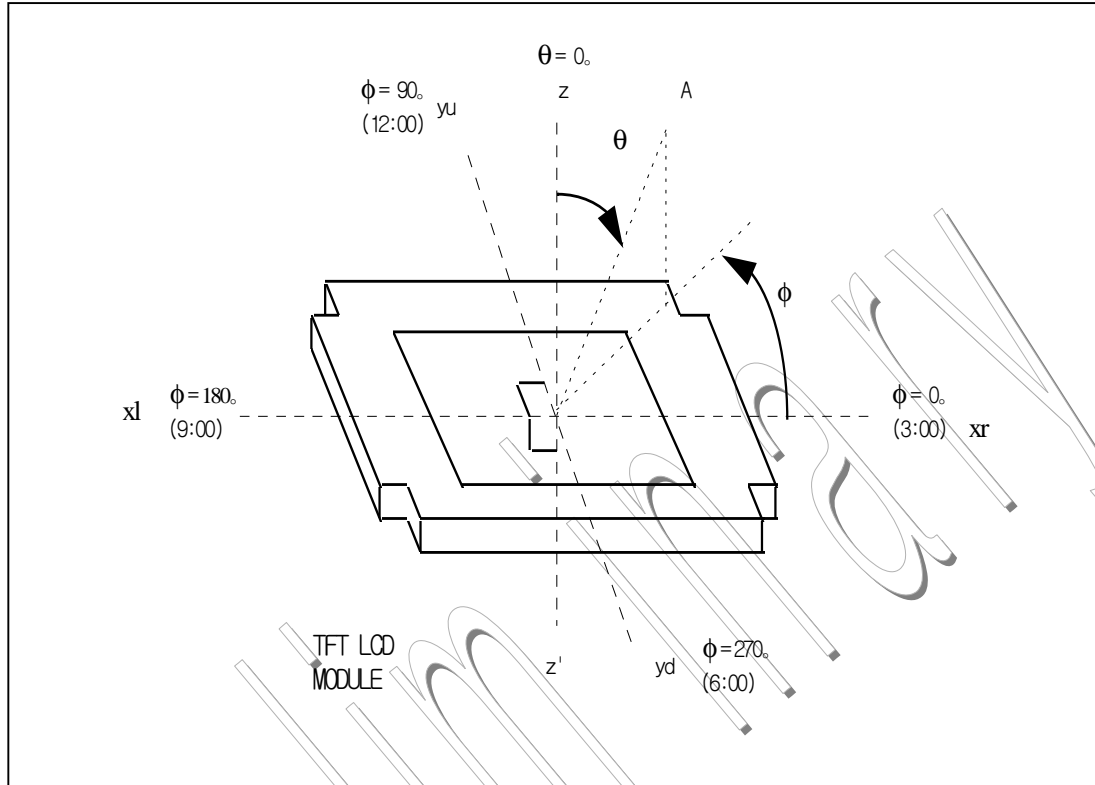

Product Specification

### 5. Mechanical Characteristics

The contents provide general mechanical characteristics for the model LM171W01-B3. In addition the figures in the next page are detailed mechanical drawing of the LCD.

Outline Dimension	Horizontal	400.0 ± 0.5mm
	Vertical	258.0 ± 0.5mm
	Depth	16.8 ± 0.5mm/ 18.5 ± 0.5mm(User Connector Area)
Bezel Area	Horizontal	376.6 ± 0.5mm
	Vertical	227.6 ± 0.5mm
Active Display Area	Horizontal	372.48mm
	Vertical	223.488mm
Weight	1900g (Typ.)	1990g (Max.)
Surface Treatment	Hard coating(3H) Anti-glare treatment of the front polarizer	

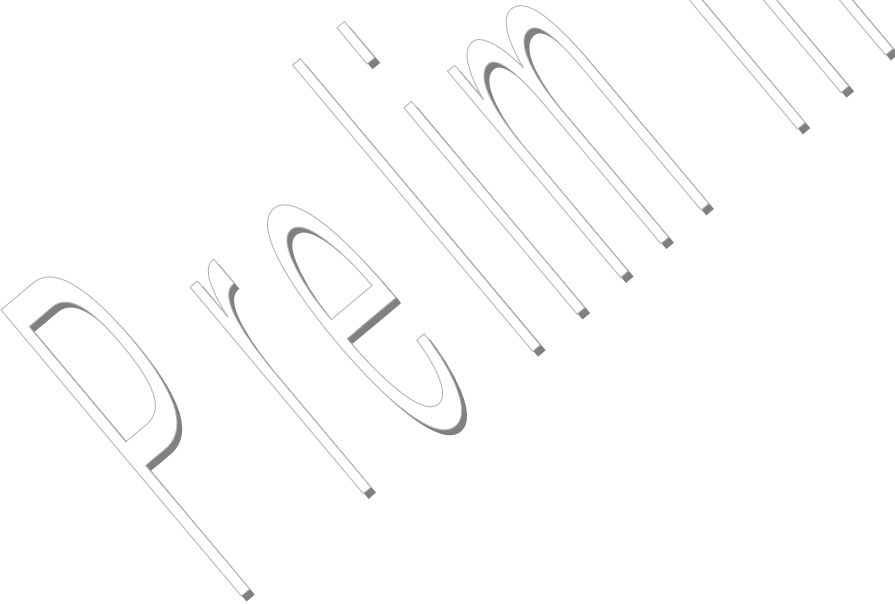

Product Specification

<FRONT VIEW>

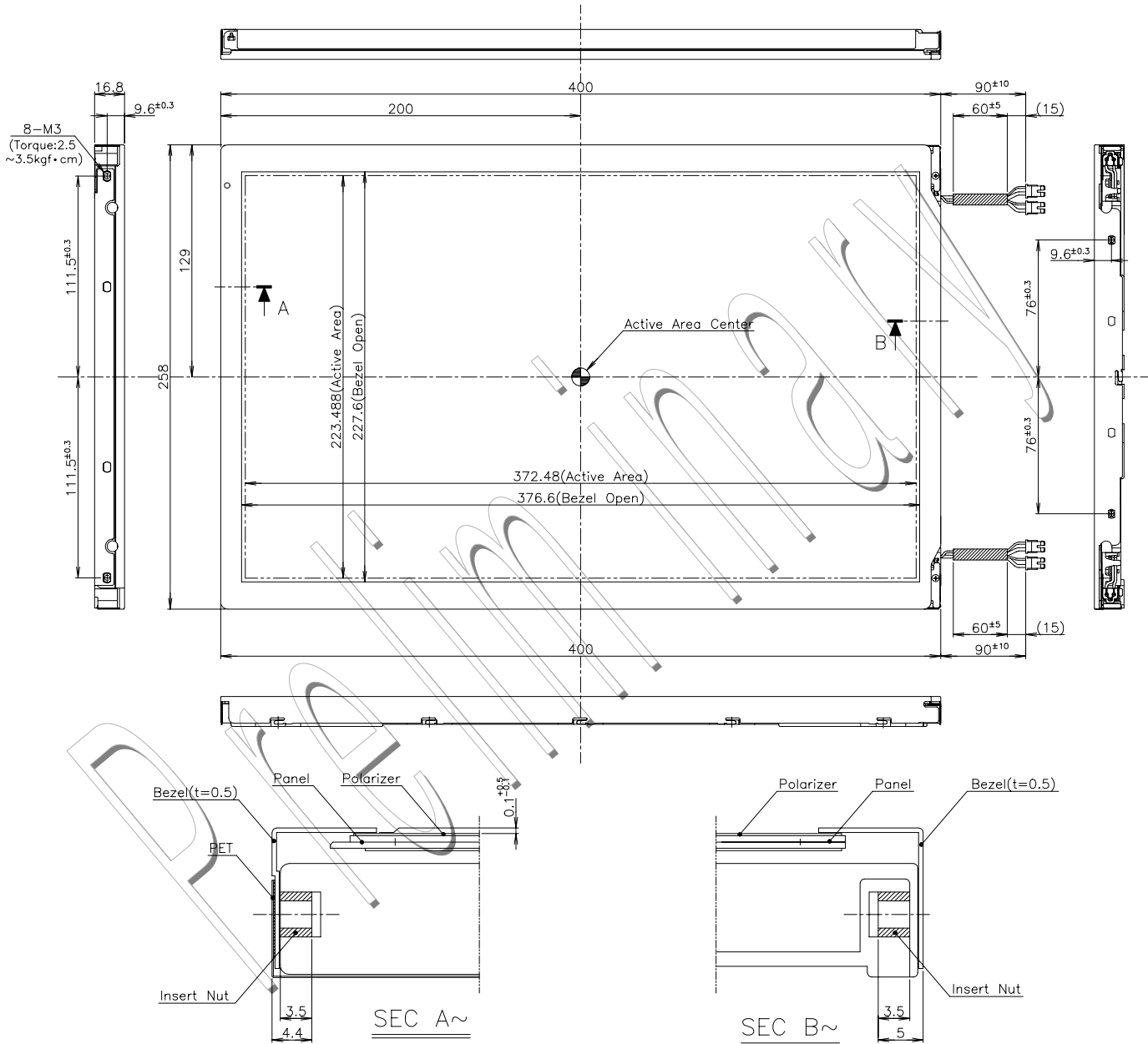

Product Specification

<REAR VIEW>

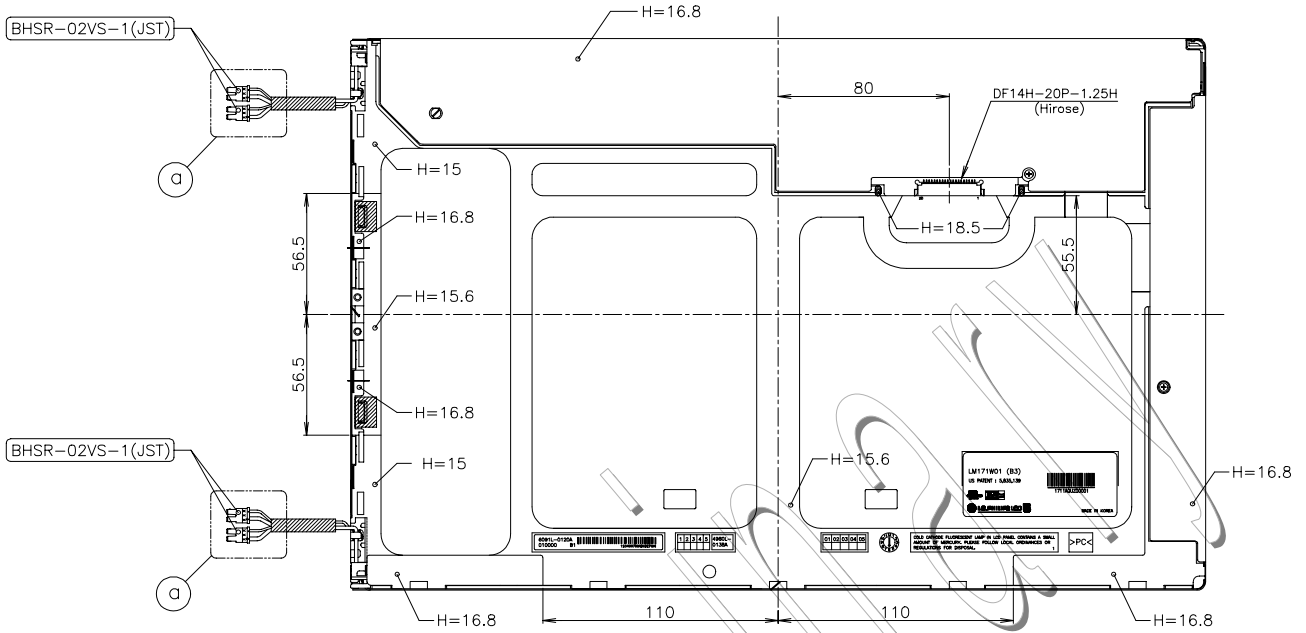

NOTES

1. Unspecified tolerances to be  $\pm 0.5$
2. Backlight cables and contraction tubes are excluded from outline dimensions.
3. Tilt and partial disposition tolerance of display area as following.
  - (1) Y-Direction :  $|A-B| < 1$
  - (2) X-Direction :  $|C-D| < 1$

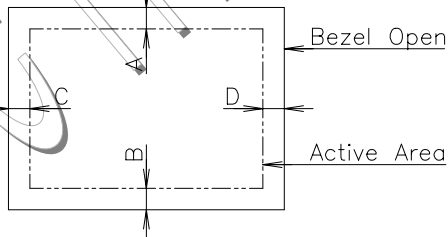
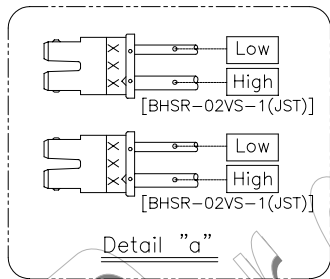

4. Lamp(CCFL) lot No. is marked at backlight connector.

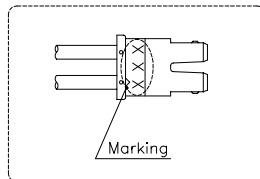

5. Do not wind conductive tape around the backlight wires.

## Product Specification

## 6. Reliability

### Environment test condition

No	Test Item	Condition
1	High temperature storage test	Ta= 60°C 240h
2	Low temperature storage test	Ta= -20°C 240h
3	High temperature operation test	Ta= 50°C 50%RH 240h
4	Low temperature operation test	Ta= 0°C 240h
5	Vibration test (non-operating)	Wave form : random Vibration level : 1.0G RMS Bandwidth : 10-500Hz Duration : X,Y,Z, 20 min One time each direction
6	Shock test (non-operating)	Shock level : 120G Waveform : half sine wave, 2ms Direction : ± X, ± Y, ± Z One time each direction
	Altitude storage / shipment	0 - 40,000 feet(12,192m)

#### { Result Evaluation Criteria }

There should be no change which might affect the practical display function when the display quality test is conducted under normal operating condition.

DRAFT

## 7. International Standards

### 7-1. Safety

- a) UL 1950 Third Edition, Underwriters Laboratories, Inc. Jan. 28, 1995.  
Standard for Safety of Information Technology Equipment Including Electrical Business Equipment.
- b) CAN/CSA C22.2 No. 950-95 Third Edition, Canadian Standards Association, Jan. 28, 1995.  
Standard for Safety of Information Technology Equipment Including Electrical Business Equipment.
- c) EN 60950 : 1992+A1: 1993+A2: 1993+C3: 1995+A4: 1997+A11: 1997  
IEC 950 : 1991+A1: 1992+A2: 1993+C3: 1995+A4: 1996  
European Committee for Electrotechnical Standardization(CENELEC)  
EUROPEAN STANDARD for Safety of Information Technology Equipment Including Electrical Business Equipment.

### 7-2. EMC

- a) ANSI C63.4 "Methods of Measurement of Radio-Noise Emissions from Low-Voltage Electrical and Electrical Equipment in the Range of 9kHz to 40GHz." American National Standards Institute(ANSI), 1992
- b) C.I.S.P.R "Limits and Methods of Measurement of Radio Interface Characteristics of Information Technology Equipment." International Special Committee on Radio Interference.
- c) EN 55022 "Limits and Methods of Measurement of Radio Interface Characteristics of Information Technology Equipment." European Committee for Electrotechnical Standardization.(CENELEC), 1998

DRAFT

Product Specification

## 8. Packing

### 8-1. Designation of Lot Mark

a) Lot Mark

A	B	C	D	E	F	G	H	I	J	K	L	M
---	---	---	---	---	---	---	---	---	---	---	---	---

A,B,C : SIZE

D : YEAR

E : MONTH

F,G : PANEL CODE

H : ASSEMBLY CODE

I,J,K,L,M : SERIAL NO.

Note

1. YEAR

Year	97	98	99	2000	2001	2002	2003	2004	2005	2006	2007
Mark	7	8	9	0	1	2	3	4	5	6	7

2. MONTH

Month	Jan	Feb	Mar	Apr	May	Jun	Jul	Aug	Sep	Oct	Nov	Dec
Mark	1	2	4	4	5	6	7	8	9	A	B	C

3. Serial No.

Year	1 ~ 99999	100000 ~
Mark	00001 ~ 99999	A0001 ~ A9999, ..... , Z9999

b) Location of Lot Mark

Serial NO. is printed on the label. The label is attached to the backside of the LCD module.  
This is subject to change without prior notice.

### 8-2. Packing Form

a) Package quantity in one box : 8 pcs

b) Box Size : 587mm × 408mm × 378mm

## 9. PRECAUTIONS

Please pay attention to the followings when you use this TFT LCD module.

### 9-1. MOUNTING PRECAUTIONS

- (1) You must mount a module using holes arranged in four corners or four sides.
- (2) You should consider the mounting structure so that uneven force (ex. Twisted stress) is not applied to the module. And the case on which a module is mounted should have sufficient strength so that external force is not transmitted directly to the module.
- (3) Please attach the surface transparent protective plate to the surface in order to protect the polarizer. Transparent protective plate should have sufficient strength in order to resist external force.
- (4) You should adopt radiation structure to satisfy the temperature specification.
- (5) Acetic acid type and chlorine type materials for the cover case are not desirable because the former generates corrosive gas of attacking the polarizer at high temperature and the latter causes circuit break by electro-chemical reaction.
- (6) Do not touch, push or rub the exposed polarizers with glass, tweezers or anything harder than HB pencil lead. And please do not rub with dust clothes with chemical treatment. Do not touch the surface of polarizer for bare hand or greasy cloth. (Some cosmetics are detrimental to the polarizer.)
- (7) When the surface becomes dusty, please wipe gently with absorbent cotton or other soft materials like chamois soaks with petroleum benzene. Normal-hexane is recommended for cleaning the adhesives used to attach front / rear polarizers. Do not use acetone, toluene and alcohol because they cause chemical damage to the polarizer.
- (8) Wipe off saliva or water drops as soon as possible. Their long time contact with polarizer causes deformations and color fading.
- (9) Do not open the case because inside circuits do not have sufficient strength.

### 9-2. OPERATING PRECAUTIONS

- (1) The spike noise causes the mis-operation of circuits. It should be lower than following voltage :  
 $V = \pm 200\text{mV}$  (Over and under shoot voltage)
- (2) Response time depends on the temperature. (In lower temperature, it becomes longer.)
- (3) Brightness depends on the temperature. (In lower temperature, it becomes lower.)  
And in lower temperature, response time (required time that brightness is stable after turned on) becomes longer.
- (4) Be careful for condensation at sudden temperature change. Condensation makes damage to polarizer or electrical contacted parts. And after fading condensation, smear or spot will occur.
- (5) When fixed patterns are displayed for a long time, remnant image is likely to occur.
- (6) Module has high frequency circuits. Sufficient suppression to the electromagnetic interference shall be done by system manufacturers. Grounding and shielding methods may be important to minimize the interference.

### 9-3. ELECTROSTATIC DISCHARGE CONTROL

Since a module is composed of electronic circuits, it is not strong to electrostatic discharge. Make certain that treatment persons are connected to ground through wrist band etc. And don't touch interface pin directly.

### 9-4. PRECAUTIONS FOR STRONG LIGHT EXPOSURE

Strong light exposure causes degradation of polarizer and color filter.

### 9-5. STORAGE

When storing modules as spares for a long time, the following precautions are necessary.

- (1) Store them in a dark place. Do not expose the module to sunlight or fluorescent light. Keep the temperature between 5°C and 35°C at normal humidity.
- (2) The polarizer surface should not come in contact with any other object.  
It is recommended that they be stored in the container in which they were shipped.

### 9-6. HANDLING PRECAUTIONS FOR PROTECTION FILM

- (1) The protection film is attached to the bezel with a small masking tape.  
When the protection film is peeled off, static electricity is generated between the film and polarizer. This should be peeled off slowly and carefully by people who are electrically grounded and with well ion-blown equipment or in such a condition, etc.
- (2) When the module with protection film attached is stored for a long time, sometimes there remains a very small amount of glue still on the Bezel after the protection film is peeled off.
- (3) You can remove the glue easily. When the glue remains on the Bezel or its vestige is recognized, please wipe them off with absorbent cotton waste or other soft material like chamois soaked with normal-hexane.