



H6849 Series

Novel Low Cost Green-Power PWM Controller

Features

- Low Cost, PWM&PFM&CRM
- Low Start-up Current (about 10 μ A)
- Low Operating Current (about 2mA)
- Current Mode Operation
- Under Voltage Lockout (UVLO)
- Built-in Synchronized Slope Compensation
- Programmable PWM Frequency
- Leading edge Blanking on Sense input
- Constant output power limiting for universal AC input
- Cycle-by-cycle current limiting
- Clamped gate output voltage 16.5V
- Over voltage protect 26.7V
- High-Voltage CMOS Process with ESD
- SOT-23-6L、SOP-8 & DIP-8 Pb-Free Packaging
- Compatible with SG5701 & SG5848 & LD7535 & OB2263/2263

Applications

- Switching AC/DC Adaptor
- Battery Charger
- Open Frame Switching Power Supply
- 384X Replacement

General Description

The H6849 is a highly integrated low cost current mode PWM controller, which is ideal for small power current mode of offline AC-DC fly-back converter applications. Making use of external resistors, the IC changes the operating frequency and automatically enters the PFM/CRM under light-load/zero-load conditions. This can minimize standby power consumption and achieve green-power functions. With a very low start-up current, the H6849 could use a large value start-up resistor (1.5Mohm). Built-in synchronized slope compensation enhances the stability of the system and avoids sub-harmonic oscillation. Dynamic peak limiting circuit minimizes output power change caused by delay time of the system over a universal AC input range. Leading

edge blanking circuit on current sense input could remove the signal glitch due to snubber circuit diode reverse recovery and thus greatly reduces the external component count and system cost in the design. Pulse-by-pulse current limiting ensures safe operation even during short-circuit.

The H6849 offers more protection like OVP (Over Voltage Protection) and OCP (Over current protection). The H6849's output driver is clamped to maximum 16.5V to protect the power MOSFET. Excellent EMI performance is achieved soft switching control at the totem pole gate driver output. H6849 is offered in SOT-23-6, SOP-8 and DIP-8 packages.



Pin Assignment

Part Number	Description
H6849NF	SOT26, Pb-free,in T/R
H6849S	SOP-8, Pb-free in T/R
H6849P	DIP-8, Pb-free in Tube

Pin Connection (Top View)

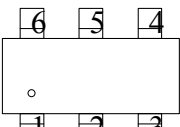
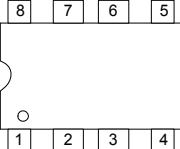
Package	Function		Description
	SOT-26	DIP-8	
 SOT-26	Pin6: GATE	Pin1: GATE	Totem-pole output to drive the external power MOSFET which is internally clamped below 18V
	Pin5: VDD	Pin2: VDD	Power Supply The internal protection circuit disables PWM output if VDD is over voltage..
		Pin3: NC	NC Pin.
 DIP -8(SOP-8)	Pin4: SENSE	Pin4: SENSE	Current sense pin, a resistor connects to sense the MOSFET current.
	Pin3: RI	Pin5: RI	This pin is to program the switching frequency. By connecting a resistor to ground to set the switching frequency.
		Pin6: NC	NC Pin
	Pin1: FB	Pin7:FB	Voltage feedback pin.Output current of this pin could controls the PWM duty cycle, If FB voltage exceeds the threshold; the internal protection circuit disables PWM output.
	Pin1: GND	Pin8: GND	GND Pin

Block Diagram

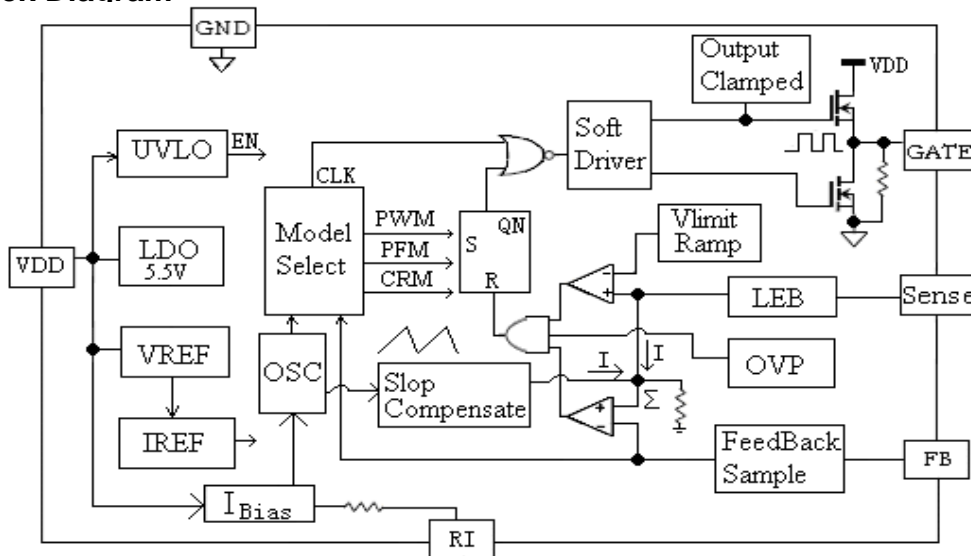

Simplified Internal Circuit Architecture



Absolute Maximum Ratings

Symbol	Parameter	Rating	Unit	
V _{DD}	Supply voltage Pin Voltage	40	V	
I _{OVP}	VDD OVP maximal enter current	20	mA	
V _{FB}	Input Voltage to FB Pin	-0.3 to 6V	V	
V _{SEN}	Input Voltage to SEN Pin	-0.3 to 6V	V	
P _D	Power Dissipation	300	mW	
	ESD Capability, HBM Model	2000	V	
	ESD Capability, Machine Model	200	V	
T _L	Lead Temperature (Soldering)	20 second SOT-23-6L	220	°C
		10 second DIP-8	260	°C
T _{STG}	Storage Temperature Range	-55 to + 150	°C	

RECOMMENDED OPERATION CONDITION

Symbol	Parameter	Min ~ Max	Unit
VDD	VDD Supply Voltage	12~20	V
RI	RI PIN Resistor Value	58~120	K ohm
T _{OA}	Operation Ambient Temperature	-20~85	°C
P _O	Output Power	0~60	W
F _{PWM}	Frequency of PWM	48~100	kHz

TYPICAL APPLICATION

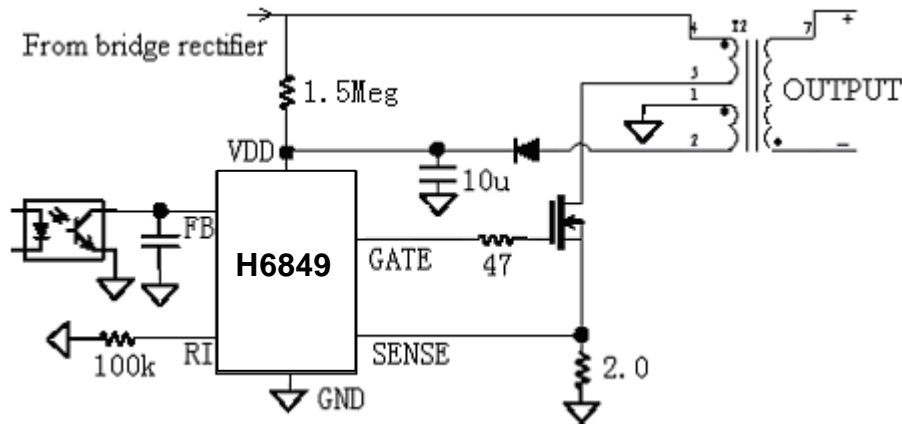



Electrical Characteristics (Ta=25°C unless otherwise noted, V_{DD} = 15V.)

Symbol	Parameter	Conditions	Min.	Typ.	Max.	Unit
Supply Voltage (V_{DD} Pin)						
I _{ST}	Startup Current			10		μA
I _{SS}	Operating Current	V _{FB} =0V		2.8		mA
		V _{FB} =3V		2.3		mA
		V _{FB} =Open		1.46		mA
V _{DDON}	Turn-on Threshold Voltage			16.1		V
V _{DDOFF}	Turn-off Threshold Voltage			11.1		V
V _{DCLAMP}	VDD Clamp Voltage	I _{VDD} =20mA		26.7		V
Voltage Feedback (FB Pin)						
I _{FB}	Short Circuit Current	V _{FB} =0V		2.8		mA
V _{FB}	Open Loop Voltage	V _{FB} =Open		4.8		V
I _{PFM}	Enter PFM, FB current			0.92		mA
I _{CRM}	Enter CRM, FB current			1.5		mA
Current Sensing (SEN Pin)						
V _{TH_L}	Minimum Voltage Lever		0.83	0.87		V
V _{TH_H}	Maximum Voltage Lever			1.0	1.05	V
T _{PD}	Delay to Output			300		ns
R _{CS}	Input Impedance			50		KΩ
Oscillator (RI Pin)						
F _{OSC}	Normal Frequency	RI=100Kohm	53	58	63	KHz
F _{PFM}	PFM Frequency	RI=100Kohm		11.6		KHZ
DC _{MAX}	Maximum Duty Cycle	RI=100Kohm		75		%
Δ F _{TEMP}	Frequency Temp. Stability	-30-85°C		5		%
T _{BLANK}	Leading-Edge Blanking Time			300		nS
GATE Drive Output (GATE Pin)						
V _{OL}	Output Low Level	V _{DD} =15V, I _O =20mA			1	V
V _{OH}	Output High Level	V _{DD} =15V, I _O =20mA	8			V
T _R	Rising Time	C _L =1000pF		450		ns
T _F	Falling Time	C _L =1000pF		130		ns
V _{GCLAMP}	Output Clamp Voltage	V _{DD} =20V		16.5		V



TYPICAL CHARACTERISTICS

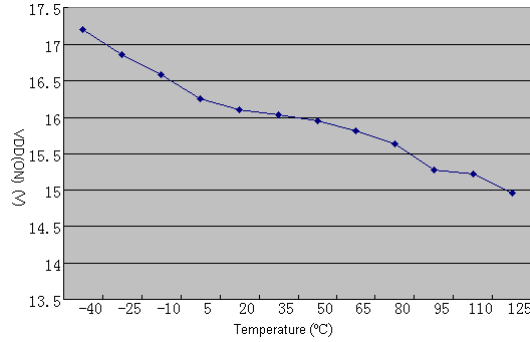

VDD startup Current VS Temperature

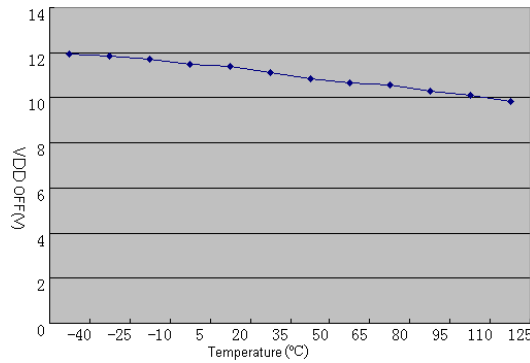

VDD (OFF) VS Temperature

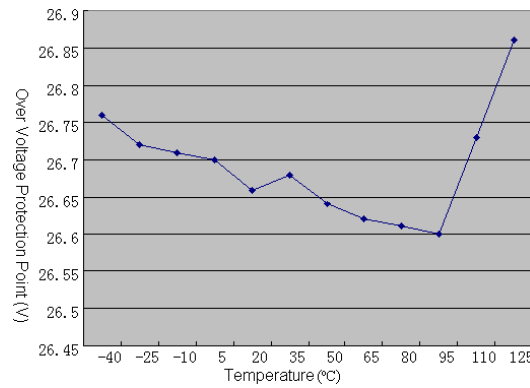

OVP VS Temperature

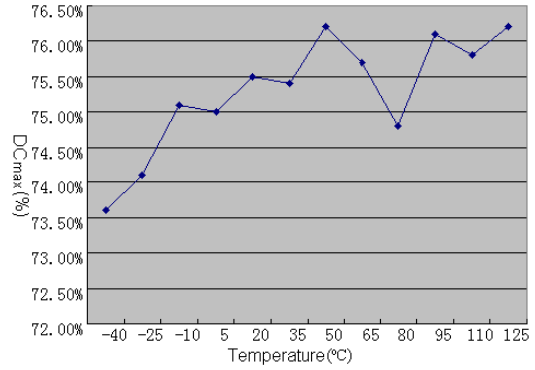

Duty cycle VS Temperature

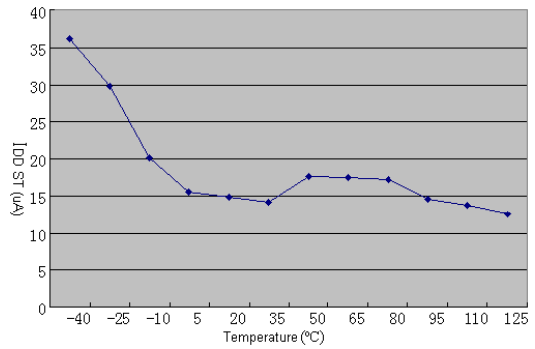

VDD startup Current VS Temperature

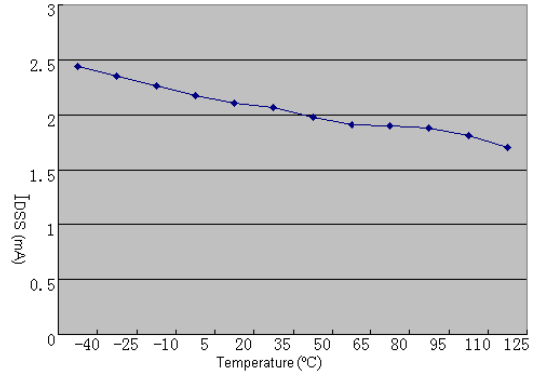

VDD Operation Current VS Temperature

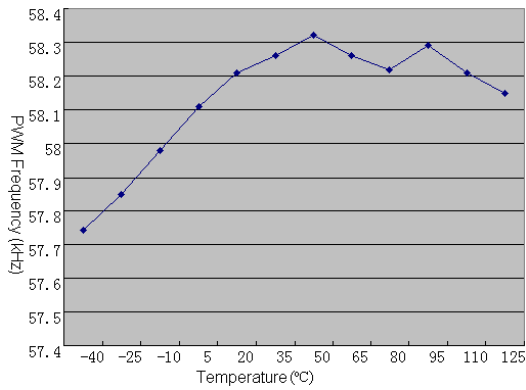

PWM frequency VS Temperature

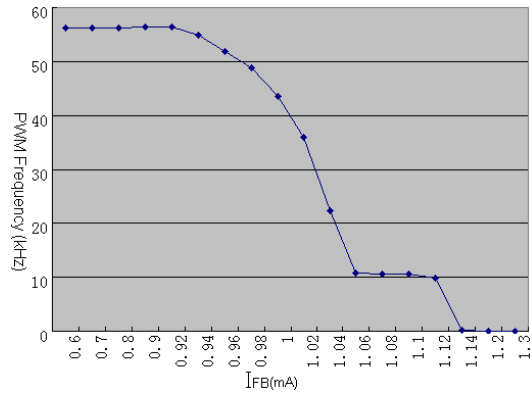

F_{osc} VS I_{FB} Current

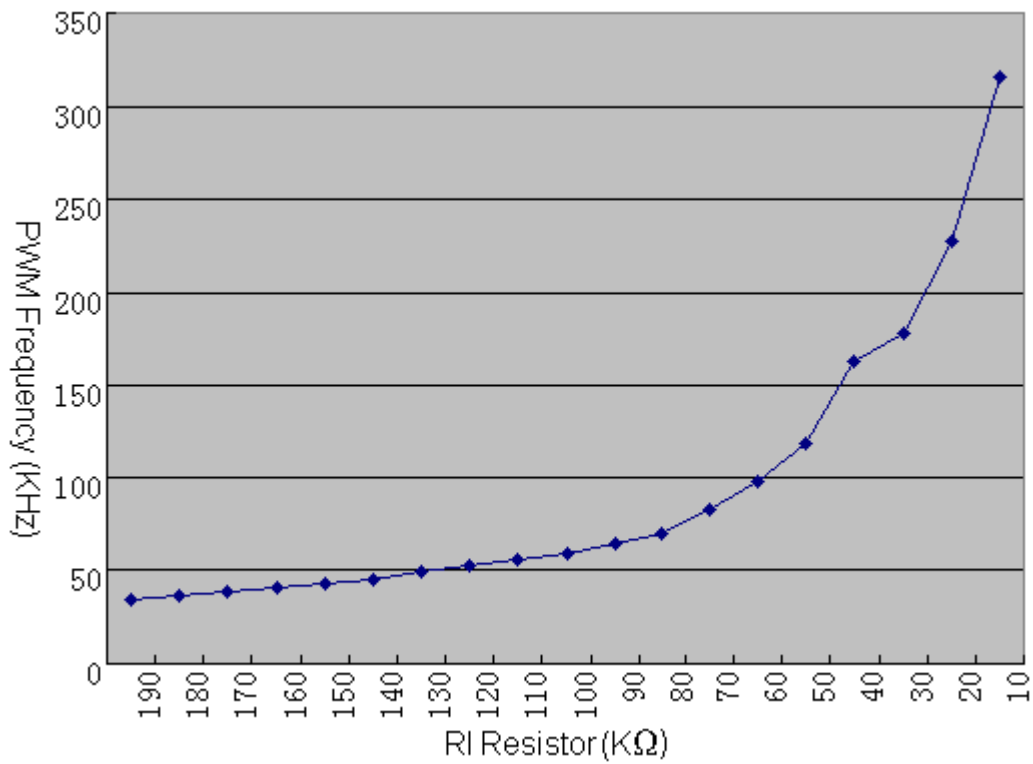

F_{osc} VS RI pin resistor



OPERATION DESCRIPTION

Current Model

Compared to voltage model control, current model control has a current feedback loop. When the voltage of the sense resistor peak current of the primary winding reaches the internal setting value V_{TH} , comparator reverse, register reset and power MOSFET cut-off. So that to detect and modulate the peak current cycle by cycle could control the output of the power supply. The current feedback has a good linear modulation rate and a fast input and output dynamic impact avoid the pole that the output filter inductance brings and the second class system descends to first class and so it widens the frequency range and optimizes overload protection and short circuit protection.

Startup Current and Under Voltage Lockout

The startup current of H6849 is set to be very low so that a large value startup resistor can therefore be used to minimize the power loss. For AC to DC adaptor with universal input range design, a 1.5 M Ω , 1/8 W startup resistor and a 10uF/25V VDD hold capacitor could be used.

The turn-on and turn-off threshold of the H6849 is designed to 16.1V/11.1V. During startup, the hold-up capacitor must be charge to 16.1V through the startup resistor. The hysteresis is implemented to prevent the shutdown from the voltage dip during startup.

Internal Bias and OSC Operation

A resistor connected between RI pin and GND pin set the internal constant current source to charge or discharge the internal fixed cap. The charge time and discharge time determine the internal clock speed and the switching frequency. Increasing the resistance will reduce the value of the input current and reduce the switching frequency. The relationship between RI pin and PWM switching frequency follows the below equation within the RI allowed range.

$$F_{osc} = \frac{5800}{RI(K\Omega)} (kHz)$$

For example, a 100k Ω resistor RI could

generate a 50uA constant current and a 58kHz PWM switching frequency. The suggested operating frequency range of H6849 is within 48KHz to 100KHz.

Green Power Operation

The power dissipation of switching mode power supply is very important in zero load or light load condition. The major dissipation result from conduction loss, switching loss and consume of the control circuit. However, all of them related to the switching frequency. There are many difference topologies has been implemented in different chip. The basic operation theory of all these approaches intended to reduce the switching frequency under light-load or no-load condition.

H6849's green power function adapts PWM, PFM and CRM combining modulation. When RI resistor is 100k, the PWM frequency is 58kHz in medium or heavy load operation. Through modifying the pulse width, H6849 could control output voltage. The current of FB pin increases when the load is in light condition and the internal mode controller enters PFM&PWM when the feedback current is over 0.92mA. The operation frequency of oscillator is to descend gradually. The invariable frequency of oscillator is 11.6kHz when the feedback current is over 1.05mA. To decrease the standby consumption of the power supply, Chip-Rail introduces the Cycle Reset Mode technology; If the feedback current were over 1.1mA, mode controller of H6849 would reset internal register all the time and cut off the gate pin, while the output voltage is lower than the set value, it would set register, gate pin operating again. Although the frequency of the internal OSC is invariable, the register would reset some pulses so that the practical frequency is decreased at the gate pin.

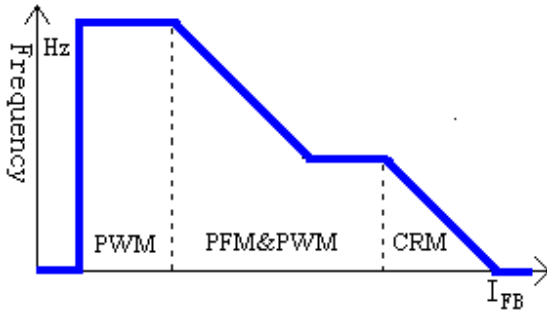

H6849 Green-Power Function Internal Synchronized Slop Compensation

Although there are more advantages of the current mode control than conventional voltage mode control, there are still several drawbacks of peak-sensing current-mode converter. Especially the open loop instability when it operates in higher than 50% of the duty-cycle. H6849 is introduced an internal slope compensation adding voltage ramp to the current sense input voltage for PWM generation to solve this problem. It improves the close loop stability greatly at CCM, prevents the sub-harmonic oscillation and thus reduces the output ripple voltage.

$$V_{SLOP} = 0.33 \times \frac{DUTY}{DUTY_{MAX}} = 0.4389 \times DUTY$$

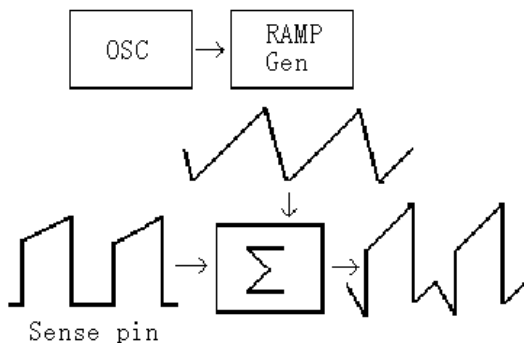

Current Sensing & Dynamic peak limiting

The current flowing by the power MOSFET comes in to being a voltage V_{SENSE} on the sense pin cycle by cycle, which compares to the internal reference voltage, controls the reverse of the internal register, limits the peak current I_{MAX} of the primary of the

transformer. The energy $E = \frac{1}{2} \times L \times I_{MAX}^2$

deposited by the transformer. So adjusting the R_{SENSE} can set the Max output power of the power supply mode. The current flowing by the power MOSFET has an extra value

$$\Delta I = \frac{V_{IN}}{L_p} \times T_D$$

due to the system delay T

that the current detected from the sense pin to power MOSFET cut off in the H6849 (Among these, V_{IN} is the primary winding voltage of the transformer and L_p is the primary wind inductance. V_{IN} ranges from 85VAC to 264VAC. To guarantee the output power is a constant for universal input AC voltage, there is a dynamic peak limit circuit to compensate the system delay T that the system delay brings on.

Leading-edge Blanking (LEB)

Each time the power MOSFET is switched on, a turn-on spike will inevitably occur at the sense pin, which would disturb the internal signal from the sampling of the R_{SENSE} . There is a 300n sec leading edge blanking time built in to avoid the effect of the turn-on spike and the power MOSFET cannot be switched off during this time. So that the conventional external RC filtering on sense input is no longer required.

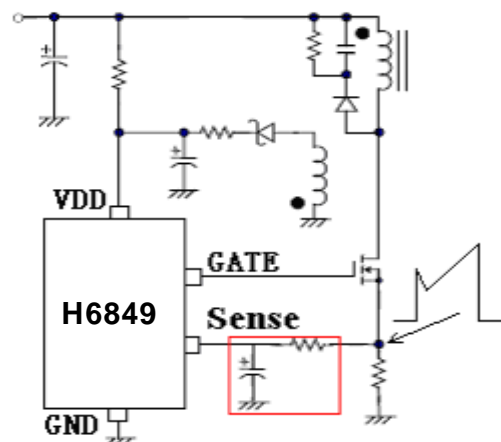

Over Voltage Protection (OVP)

There is a 26.7V over-voltage protection circuit in the H6849 to improve the credibility and extend the life of the chip. The GATE is to shutdown immediately when the voltage



of the VDD is over 26.7V and the voltage of VDD is to descend rapidly.

Gate Driver & Soft Clamped

H6849' output designs a totem pole to drive a periphery power MOSFET. The dead time is introduced to minimize the transfixion

current when the output is drove. The NMOS is shut off when the other NMOS is turned on. The clamp technology is introduced to protect the periphery power MOSFET from breaking down.

PACKAGE DEMENSIONS

DIP-8L

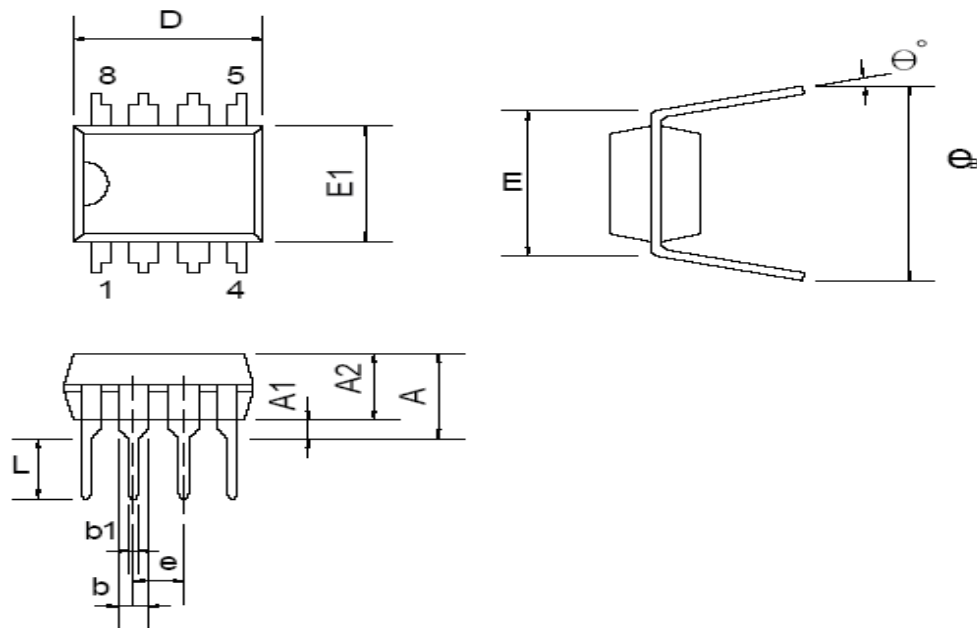

Dimensions

Symbol	Millimeters			Inches		
	Min.	Typ.	Max.	Min.	Typ.	Max.
A			5.334			0.210
A1	0.381			0.015		
A2	3.175	3.302	3.429	0.125	0.130	0.135
b		1.524			0.060	
b1		0.457			0.018	
D	9.017	9.271	10.160	0.355	0.365	0.400
E		7.620			0.300	
E1	6.223	6.350	6.477	0.245	0.250	0.255
e		2.540			0.100	
L	2.921	3.302	3.810	0.115	0.130	0.150
eB	8.509	9.017	9.525	0.335	0.355	0.375
θ°	0°	7°	15°	0°	7°	15°



SOT-23-6L

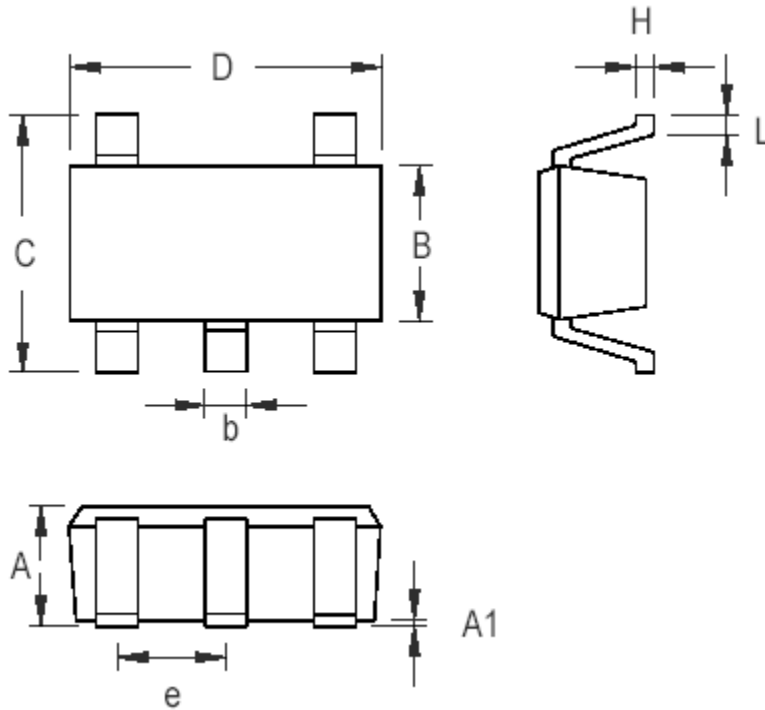

Symbol	Dimensions In Millimeters		Dimensions In Inches	
	Min	Max	Min	Max
A	0.700	1.000	0.028	0.039
A1	0.000	0.100	0.000	0.004
B	1.397	1.803	0.055	0.071
b	0.300	0.559	0.012	0.022
C	2.591	3.000	0.102	0.118
D	2.692	3.099	0.106	0.122
e	0.838	1.041	0.033	0.041
H	0.080	0.254	0.003	0.010
L	0.300	0.610	0.012	0.024



SOP-8L

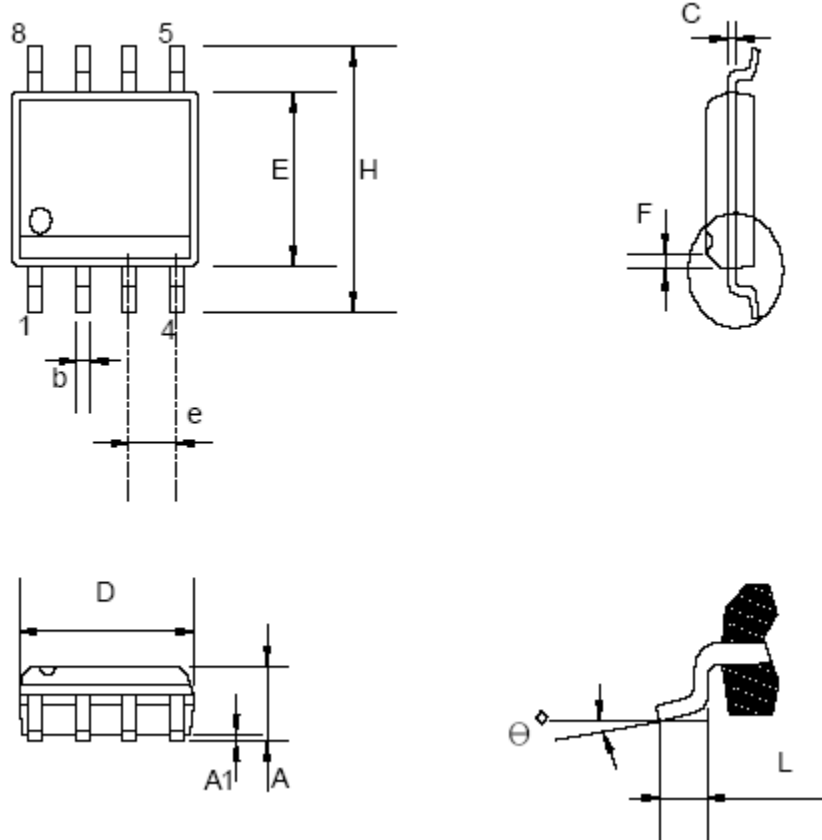

Dimensions DISCLAIMERS

Symbol	Millimeter			Inch		
	Min.	Typ.	Max.	Min.	Typ.	Max.
A	1.346		1.752	0.053		0.069
A1	0.101		0.254	0.004		0.010
b		0.406			0.016	
c		0.203			0.008	
D	4.648		4.978	0.183		0.196
E	3.810		3.987	0.150		0.157
e	1.016	1.270	1.524	0.040	0.050	0.060
F		0.381X45			0.015X45	
H	5.791		6.197	0.228		0.244
L	0.406		1.270	0.016		0.050
θ	0°		8°	0°		8°



Typical applications
12V/2A 24W Power Supply
Schematic:

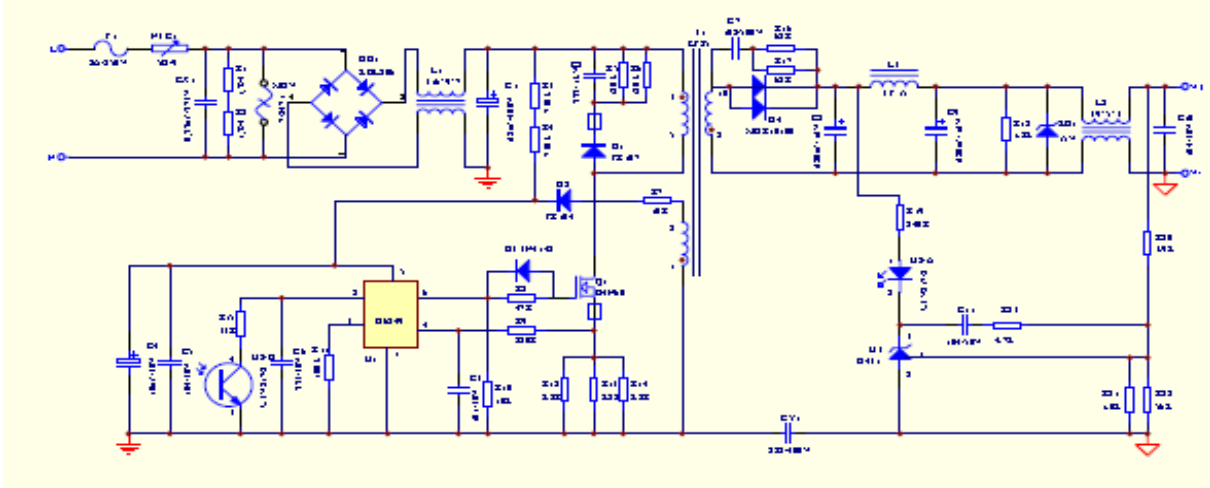

Bill of Material:

Designator	Part Type	Footprint	Number
12V-2A-BOM			
R1,R2	1.2M ±5%	SMD 1206	2
R3,R4	750K ±5%	SMD 1206	2
R5,R6	180K ±5%	SMD 1206	2
R7	10R ±5%	SMD 1206	1
R8	47R ±5%	SMD 0805	1
R9	220R ±5%	SMD 0805	1
R10	10K ±5%	SMD 0805	1
R11	100K ±5%	SMD 0805	1
R12,R13,R14	2.2R ±5%	SMD 1206	3
R15	33R ±5%	SMD 1206	1
R16,R17	62R±5%	SMD 1206	2
R18	1.8K±5%	SMD 1206	1
R19	240R±5%	SMD 0805	1
R20	3.9K±1%	SMD 0805	1
R21	1K±1%	SMD 0805	1
R22	56K±5%	SMD 0805	1
R23	4.7K±5%	SMD 0805	1
C1	47uF/400V	EC	1
C2	222/1KV	CC	1
C3	101/50V	SMD 0805	1
C4	10uF/50V	EC 6X11mm	1
C5	104/50V	SMD 0805	1
C6	223/50V	SMD 0805	1
C7	102/500V	CC	1
C8,C9	680UF/16V	EC	2
C10,C11	104/50V	SMD 0805	2



U1	H6849	PWM IC SOT-23-6	1
U2	PC817C	DIP-4	1
U3	H431	TO-92 1% KC	1
CX1	0.22UF/275V	X	1
CY1	222/400V	Y	1
F1	2A250V	φ 3mm*11MM	1
NTC1	5D-9	NTC PIN:6mm	1
MOV	7D471	MOV PIN:5mm	1
L1	UU9.8	Min:18MH 0.2mm T16*9*7	1
L2	T9*5*3	L 8UH	1
L3	T3*15	15UH	1
Q1	H4N60	4A600V TO-220	1
T1	EF25	T LP=1.5MH ±3%	1
BD1	KBL206	2A/600V	1
D1	FR107	DO-41	1
D2	FR104	DO-41	1
D3	1N4148	SMD	1
D4	MBR10100	10A100V TO-220	1
ZD1	15V	ZD 1W	1

Transformer Structure and Material:

1. Schematic.

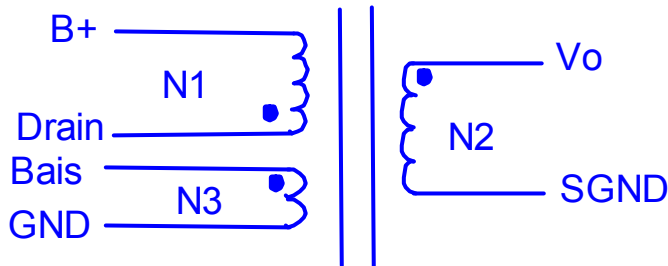

2. Winding Configuration

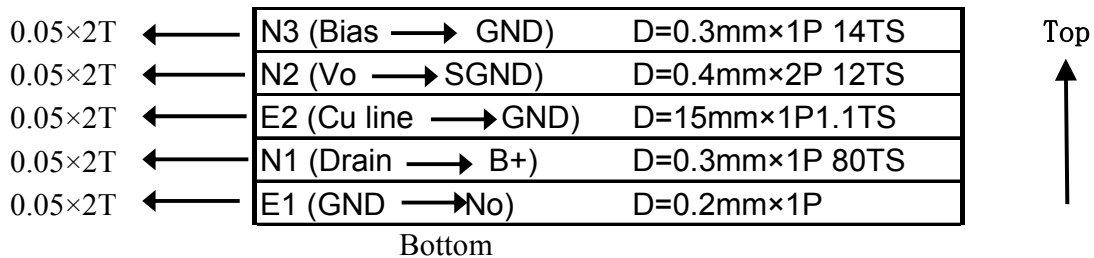

Bobbin: L

CORE:EF25 TDK PC40