



H3842P / H3842S

HIGH PERFORMANCE CURRENT MODE PWM CONTROLLERS

Description

The H3842 Series is high performance fixed frequency current mode controllers. That is specifically designed for Off-Line and DC To DC converter applications offering the designer a costeffective solution with minimal external components. These integrated circuits feature a trimmed oscillator for precise duty cycle control. A temperature compensated reference, high gain error amplifier, current sensing compar-a-tor, and a high current totem pole output ideally suited for driving a power MOSFET. Also included are protective features consisting of input and reference undervoltage lockouts each with hysteresis, cycle-by-cycle current limiting, programmable output deadtime, and a latch for single pulse metering.

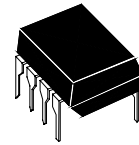

8-Lead Plastic **DIP-8**
Package Code: P

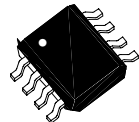

8-Lead Plastic **SO-8**
Package Code: S

Features

- Trimmed Oscillator for Precise Frequency Control
- Oscillator Frequency Guaranteed at 250 kHz
- Current Mode Operation to 500 kHz
- Automatic Feed Forward Compensation
- Latching PWM for Cycle-By-Cycle Current Limiting
- Internally Trimmed Reference with Undervoltage Lockout
- High Current Totem Pole Output
- Undervoltage Lockout with Hysteresis
- Low Startup and Operating Current

Absolute Maximum Ratings

Symbol	Parameter	Value	Unit
V_i	Supply Voltage (low impedance source)	30	V
V_i	Supply Voltage ($I_i < 30\text{mA}$)	Self Limiting	
I_o	Output Current	± 1	A
E_o	Output Energy (capacitive load)	5	μJ
	Analog Inputs (pin 2, 3)	-0.3 to 5.5	V
	Error Amplifier Output Sink Current	10	mA
P_{tot}	Power Dissipation at $T_{amb} \leq 25^\circ\text{C}$	800	mW
T_{stg}	Storage Temperature Range	-65 to 150	$^\circ\text{C}$
T_J	Junction Operating Temperature	-40 to 150	$^\circ\text{C}$
T_L	Lead Temperature (soldering 10s)	300	$^\circ\text{C}$

Thermal Data

Symbol	Description	DIP-8	SO-8	Units
$R_{th\ j-amb}$	Thermal Resistance Junction-ambient	100	150	$^\circ\text{C/W}$



Block Diagram

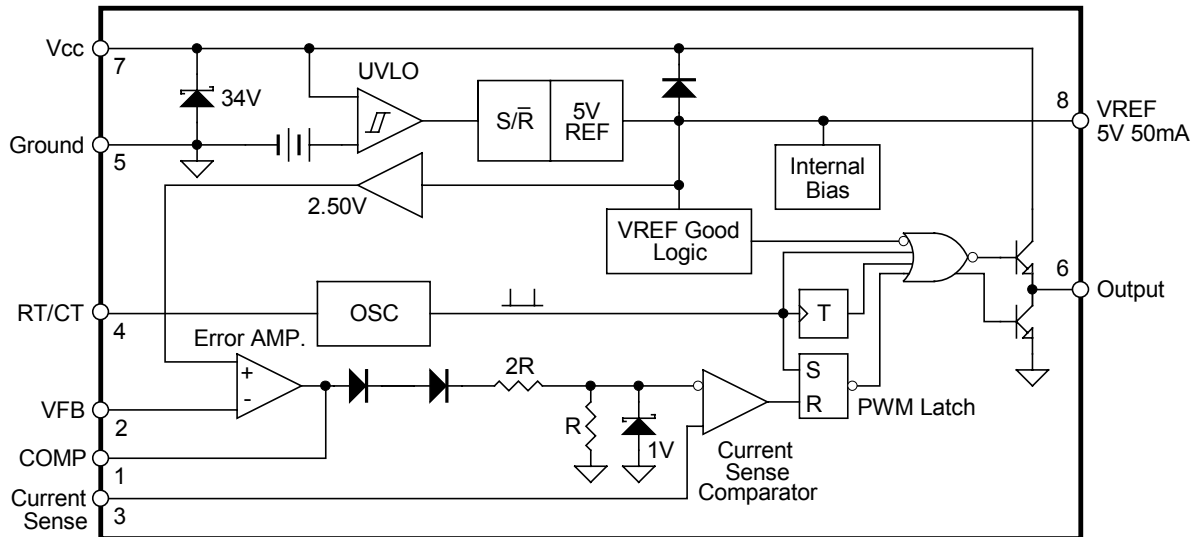

Pin Connection (Top View)

Package	Function	Description
<p>DIP-8</p> <p>SO-8</p>	Pin1: Compensation	This pin is the Error Amplifier output and is made available for loop compensation.
	Pin2: Voltage Feedback	This is the inverting input of the Error Amplifier. It's normally connected to the switching power supply output through a resistor divider.
	Pin3: Current Sense	A voltage proportional to inductor current is connected to this input. The PWM uses this information to terminate the output switch conduction.
	Pin4: RT/CT	The oscillator frequency and maximum output duty cycle are programmed by connecting resistor RT to Vref and capacitor CT to ground. Operation to 500kHz is possible.
	Pin5: Ground	This pin is the combined control circuitry and power ground.
	Pin6: Output	This output directly drives the gate of a power MOSFET. Peak currents up to 1A are sourced and sunk by this pin.
	Pin7: Vcc	This pin is the positive supply of the control IC.
	Pin8: Vref	This is the reference output. It provides charging current for capacitor CT through resistor RT.



Electrical Characteristics

Unless otherwise stated, specifications apply for $0 \leq T_{amb} \leq 70^\circ\text{C}$ $V_{CC}=15\text{V}$ (Note 1);

$R_T=680\Omega$, $C_T=0.022\mu\text{F}$ for triangular mode, $R_T=10\text{k}$, $C_T=3.3\text{nf}$ for sawtooth mode

Symbol	Parameter	Test Conditions	Min.	Typ.	Max.	Units
<i>Reference Section</i>						
V_{REF}	Reference Output Voltage	$T_J=25^\circ\text{C}$, $I_o=1\text{mA}$	4.90	5	5.1	V
ΔV_{REF}	Line Regulation	$12\text{V} \leq V_{in} \leq 25\text{V}$	-	2.0	20	mV
ΔV_{REF}	Load Regulation	$1\text{mA} \leq I_o \leq 20\text{mA}$	-	3.0	25	mV
$\Delta V_{REF}/\Delta T$	Temperature Stability	(Note 2)	-	0.2	-	mV/ $^\circ\text{C}$
	Total Output Variation	Line, Load, Temp (Note 2)	4.82	-	5.18	V
e_N	Output Noise Voltage	$10\text{Hz} \leq f \leq 10\text{kHz}$, $T_J=25^\circ\text{C}$ (Note 2)	-	50	-	μV
	Long Term Stability	$T_a=125^\circ\text{C}$, 1000Hrs (Note 2)	-	5	-	mV
I_{SC}	Output Short Current	$T_a=25^\circ\text{C}$	-30	-100	-180	mA
<i>Oscillator Section</i>						
f_{OSC}	Frequency	$T_J=25^\circ\text{C}$	47	52	57	KHz
		$T_{low} \leq T_A \leq T_{high}$	46	52	60	KHz
$\Delta f_{OSC}/\Delta V$	Frequency Change with Volt.	$12\text{V} \leq V_{CC} \leq 25\text{V}$	-	0.2	1	%
$\Delta f_{OSC}/\Delta T$	Frequency Change with Temp.	$T_{low} \leq T_A \leq T_{high}$ (Note 2)	-	5	-	%
		$T_J=25^\circ\text{C}$	-	0.5	-	%
V_{OSC}	Oscillator Voltage Swing	Peak to Peak	-	1.7	-	V
I_{dischg}	Discharge Current ($V_{OSC}=2\text{V}$)	$T_J=25^\circ\text{C}$	7.8	8.3	9.3	mA
		$T_{low} \leq T_A \leq T_{high}$	7.2	-	9.5	mA
<i>Error Amplifier Section</i>						
V_2	Voltage Feedback Input	$V_O=2.5\text{V}$	2.42	2.50	2.58	V
I_b	Input Bias Current	$V_{FB}=5.0\text{V}$	-	-0.1	-2.0	μA
A_{VOL}	Open Loop Voltage Gain	$2 \leq V_O \leq 4\text{V}$	65	90	-	dB
BW	Unity Gain Bandwidth	$T_J=25^\circ\text{C}$ (Note 2)	0.7	1.0	-	MHz
PSRR	Power Supply Rejection Ratio	$12\text{V} \leq V_{CC} \leq 25\text{V}$	60	70	-	dB
I_o	Output Current	Sink ($V_O=1.1\text{V}$, $V_{FB}=2.7\text{V}$)	2.0	12	-	mA
		Source ($V_O=5.0\text{V}$, $V_{FB}=2.3\text{V}$)	-0.5	-1.0	-	mA
$V_{OUT-High}$	Output Voltage Swing High State	$V_{FB}=2.3\text{V}$, $R_L=15\text{K}$ to ground	5	6	-	V
$V_{OUT-Low}$	Output Voltage Swing Low State	$V_{FB}=2.7\text{V}$, $R_L=15\text{K}$ to V_{REF}	-	0.7	1.1	V
<i>Current Sense Section</i>						
G_V	Current Sense Input Voltage Gain	(Notes 3 & 4)	2.85	3.0	3.15	V/V
V_3	Maximum Input Signal	$V_{PIN1}=5\text{V}$ (Note 3)	0.9	1.0	1.1	V
SVR	Supply Voltage Rejection Ratio	$12\text{V} \leq V_{CC} \leq 25\text{V}$ (Note 3)	-	70	-	dB
I_b	Input Bias Current		-	-2.0	-10	μA
	Propagation Delay	$T_J=25^\circ\text{C}$ (Note 2)	-	150	300	nS



Electrical Characteristics (continued)

Symbol	Parameter	Test Conditions	Min.	Typ.	Max.	Units
<i>Output Section</i>						
V _{OL}	Output Voltage (Low State)	I _{sink} =20mA	-	0.1	0.4	V
		I _{sink} =200mA	-	1.5	2.2	V
V _{OH}	Output Voltage (High State)	I _{source} =20mA	13	13.5	-	V
		I _{source} =200mA	12	13.4	-	V
V _{OLS}	Output Voltage with UVLO Activated	V _{CC} =6V, I _{sink} =1mA	-	-0.1	-1.1	V
t _r	Output Voltage Rise Time	T _J =25°C, C _L =1.0nF (Note 2)	-	50	150	nS
t _f	Output Voltage Fall Time	T _J =25°C, C _L =1.0nF (Note 2)	-	50	150	nS
<i>Under-Voltage Lockout Section</i>						
	Start Threshold		14.5	16	17.5	V
	Min. Operating Voltage	After Turn On	8.5	10	11.5	V
<i>PWM Section</i>						
DC _{max}	Maximum Duty Cycle		94	96	-	%
DC _{min}	Minimum Duty Cycle		-	-	0	%
<i>Total Device</i>						
I _{st}	Start-Up Current		-	0.1	0.5	mA
I _i	Operating Supply Current	V _{pin2} =V _{pin3} =0, R _T =10K, C _T =3.3nF	-	11	17	mA
V _{iz}	V _{CC} Zener Voltage	I _{CC} =25 mA	-	34	-	V

Note 1: Adjust V_{CC} above the start threshold before setting at 15V.

Note 2: These parameters, although guaranteed are not 100% tested in production.

Note 3: Parameter measured at trip point of latch with V_{pin2}=0.

Note 4: Gain defined as: $A = V_{pin1}/V_{pin3}$, $0 \leq V_{pin3} \leq 0.8V$



Characteristics Curve

