



# H1117 Series

1.2A Low Dropout Positive Voltage Regulator

## Features

- Low Dropout Voltage 1.2V at 1.2A
- Adjustable or Fixed Voltage (1.8V, 2.5V, 3.3V, 5V)
- Over Current Protection
- Thermal Overload Protection
- Maximum Line Regulation 0.45%
- Maximum Load Regulation 0.4%
- Adjust Pin Current Less Than 90  $\mu$ A

## Applications

- SCSI-2 Active Termination
- High Efficiency Linear Regulators
- 5V to 3.3V Voltage Converter
- Battery Charger
- Battery Management Circuits For Notebook And Palmtop PCs
- Core Voltage Supply: FPGA, PLD, DSP, CPU

## General Description

The H1117 Series are available in fixed and adjustable output voltage versions. Over current and thermal overload protection are integrated onto the chip. Output current will decrease while it reaches the preset current or temperature limit. The dropout voltage is specified at 1.2V Maximum at full rated output current. H1117 Series provide excellent regulation over variations due to changes in line, load and temperature. H1117 Series are three terminal regulators and available in popular packages.

## Device Selection Guide

Device	Output Voltage	Package	Device	Output Voltage	Package
H1117M-Adj	1.3V to 4V	SOT-89	H1117J-Adj	1.3V to 4V	TO-252
H1117M-Fix	1.8V, 2.5V, 3.3V, 5V		H1117J-Fix	1.8V, 2.5V, 3.3V, 5V	
H1117SJ-Adj	1.3V to 4V	SOT-223	H1117E-Adj	1.3V to 4V	TO-220AB
H1117SJ-Fix	1.8V, 2.5V, 3.3V, 5V		H1117E-Fix	1.8V, 2.5V, 3.3V, 5V	

## Absolute Maximum Ratings

Parameter	Symbol	Maximum	Units
Input Voltage	$V_{IN}$	20	V
Power Dissipation	$P_D$	Internally Limited *	W
Operating Junction Temperature Range	$T_{OPR}$	0 To +125	$^{\circ}$ C
Storage Temperature Range	$T_{STG}$	-65 To +150	$^{\circ}$ C
Lead Temperature (Soldering) 5 Sec	$T_{LEAD}$	260	$^{\circ}$ C
Electrostatic Discharge Sensitivity		2	KV/Min

\*: SOT-223: 0.9W(Max.), SOT-89: 0.6W(Max.), TO-252: 0.9W(Max.), TO-220: 2.1W(Max.)

### H1117 Series Pin Assignment

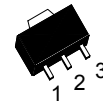

3-Lead Plastic **SOT-89**  
Package Code: M  
Pin 1: ADJ/GND  
Pin 2:  $V_{OUT}$   
Pin 3:  $V_{IN}$

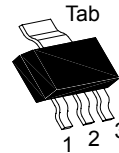

3-Lead Plastic **SOT-223**  
Package Code: SJ  
Pin 1: ADJ/GND  
Pin 2 & Tab:  $V_{OUT}$   
Pin 3:  $V_{IN}$

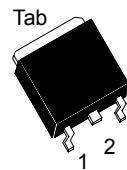

3-Lead Plastic **TO-252**  
Package Code: J  
Pin 1: ADJ/GND  
Pin 2 & Tab:  $V_{OUT}$   
Pin 3:  $V_{IN}$

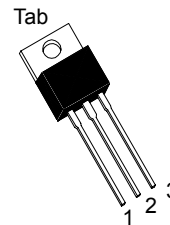

3-Lead Plastic **TO-220AB**  
Package Code: E  
Pin 1: ADJ/GND  
Pin 2 & Tab:  $V_{OUT}$   
Pin 3:  $V_{IN}$



### Electrical Characteristics (C<sub>i</sub>=10uF, C<sub>o</sub>=100uF, unless otherwise noted.)

Parameter	Test Conditions	Min.	Typ.	Max.	Units
<b>Output Voltage</b>					
H1117-1.8	I <sub>O</sub> =0mA, V <sub>IN</sub> =3.3V	1.782	1.8	1.818	V
H1117-2.5	I <sub>O</sub> =0mA, V <sub>IN</sub> =4V	2.475	2.5	2.525	V
H1117-3.3	I <sub>O</sub> =0mA, V <sub>IN</sub> =4.8V	3.27	3.3	3.33	V
H1117-5	I <sub>O</sub> =0mA, V <sub>IN</sub> =6.5V	4.95	5	5.05	V
<b>Reference Voltage</b>					
H1117-Adj	I <sub>O</sub> =10mA, V <sub>IN</sub> -V <sub>O</sub> =3V	1.238	1.25	1.262	V
<b>Line Regulation</b>					
H1117-1.8	I <sub>O</sub> =0mA, V <sub>IN</sub> =3.3~10V	-	1	6	mV
H1117-2.5	I <sub>O</sub> =0mA, V <sub>IN</sub> =4~10V	-	1	7	mV
H1117-3.3	I <sub>O</sub> =0mA, V <sub>IN</sub> =4.8~10V	-	2	7	mV
H1117-5	I <sub>O</sub> =0mA, V <sub>IN</sub> =6.5~10V	-	3	10	mV
H1117-Adj	I <sub>O</sub> =10mA, V <sub>IN</sub> -V <sub>O</sub> =1.5~10V	-	0.1	0.4	%
<b>Load Regulation</b>					
H1117-1.8	I <sub>O</sub> =0~800mA, V <sub>IN</sub> =3.3V, T <sub>J</sub> =25°C	-	-	0.4	%
	I <sub>O</sub> =0~1200mA, V <sub>IN</sub> =3.3V, <sup>NOTE1</sup>	-	-	1	%
H1117-2.5	I <sub>O</sub> =0~800mA, V <sub>IN</sub> =4V, T <sub>J</sub> =25°C	-	-	0.4	%
	I <sub>O</sub> =0~1200mA, V <sub>IN</sub> =4V, <sup>NOTE1</sup>	-	-	1	%
H1117-3.3	I <sub>O</sub> =0~800mA, V <sub>IN</sub> =4.8V, T <sub>J</sub> =25°C	-	-	0.4	%
	I <sub>O</sub> =0~1200mA, V <sub>IN</sub> =4.8V, <sup>NOTE1</sup>	-	-	1	%
H1117-5	I <sub>O</sub> =0~800mA, V <sub>IN</sub> =6.5V, T <sub>J</sub> =25°C	-	-	0.4	%
	I <sub>O</sub> =0~1200mA, V <sub>IN</sub> =6.5V, <sup>NOTE1</sup>	-	-	1	%
H1117-Adj	I <sub>O</sub> =0~800mA, V <sub>IN</sub> =2.75V, T <sub>J</sub> =25°C	-	-	0.4	%
	I <sub>O</sub> =0~1200mA, V <sub>IN</sub> =2.75V, <sup>NOTE1</sup>	-	-	1	%
<b>Dropout Voltage</b> <sup>NOTE3</sup>					
All H1117 Series	I <sub>O</sub> =100mA, T <sub>J</sub> =25°C	-	1.05	1.15	V
	I <sub>O</sub> =500mA, T <sub>J</sub> =25°C	-	1.1	1.15	V
	I <sub>O</sub> =1200mA, T <sub>J</sub> =25°C	-	1.2	1.3	V
	I <sub>O</sub> =1200mA	-	1.2	1.55	V
<b>Current Limit</b>					
All H1117 Series	V <sub>IN</sub> -V <sub>O</sub> =1.5V	2000	2600	3200	mA
<b>Minimum Load Current</b>					
H1117-ADJ <sup>NOTE1 &amp; NOTE2</sup>	V <sub>IN</sub> -V <sub>O</sub> =13.75V <sup>NOTE1 &amp; NOTE2</sup>	-	1.7	5	mA
<b>Quiescent Current</b>					
H1117-Fix <sup>NOTE1</sup>	V <sub>IN</sub> -V <sub>O</sub> =5V <sup>NOTE1</sup>	-	6	10	mA
Adjust Pin Current <sup>NOTE1 &amp; NOTE2</sup>	I <sub>O</sub> =10mA, V <sub>IN</sub> -V <sub>O</sub> =1.5V <sup>NOTE1 &amp; NOTE2</sup>	-	50	120	uA
Adjust Pin Current Change	I <sub>O</sub> =10mA, V <sub>IN</sub> -V <sub>O</sub> =1.4V~10V	-	0.5	5	uA
<b>Ripple Rejection</b>					
All H1117 Series	f=120MHz, V <sub>IN</sub> -V <sub>O</sub> =3V+1.5Vpp, C <sub>O</sub> =22uF	-	62	-	dB
<b>Temperature Drift</b>					
H1117-Fix	T <sub>J</sub> =0~25°C	-	0.5	-	%
H1117-Adj	T <sub>J</sub> =0~25°C	-	2	-	%

Note: 1. Specification applies over the full operating junction temperature range, 0~125°C

2. H1117-Adj require a minimum load current for ±3% regulation

3. Dropout voltage is the input voltage minus output voltage that produces a 1% decrease in output voltage.



### Characteristics Curve

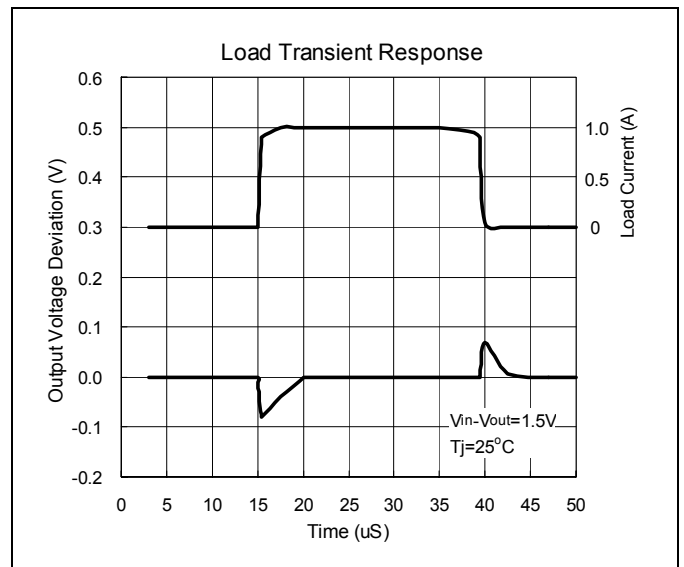
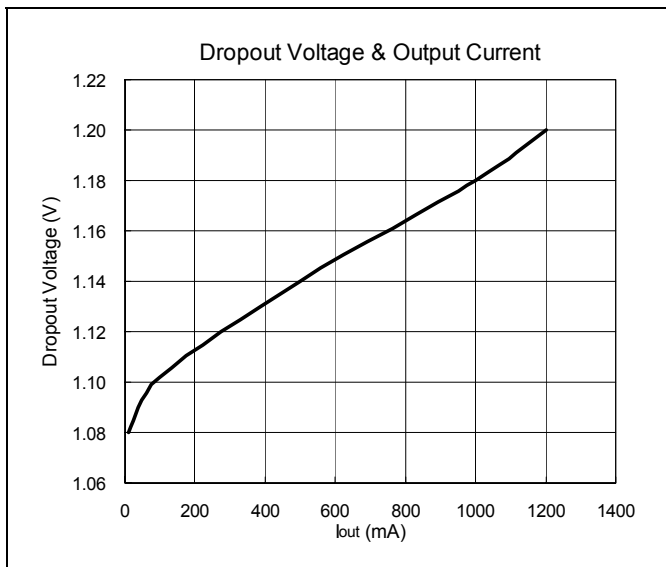
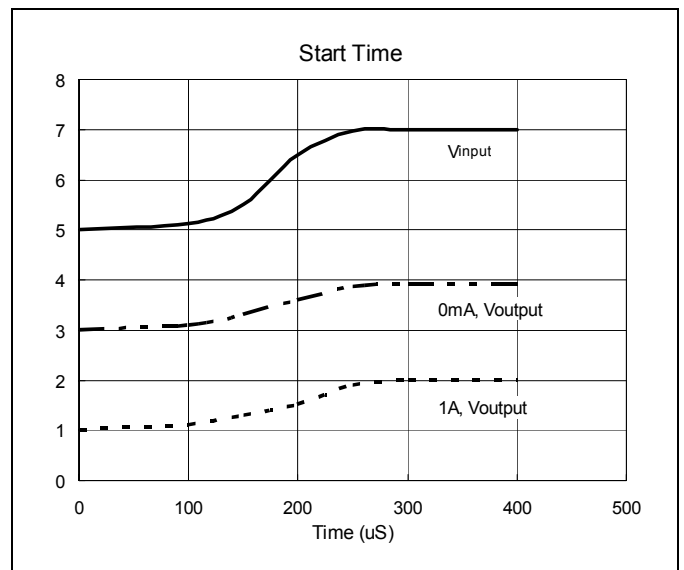
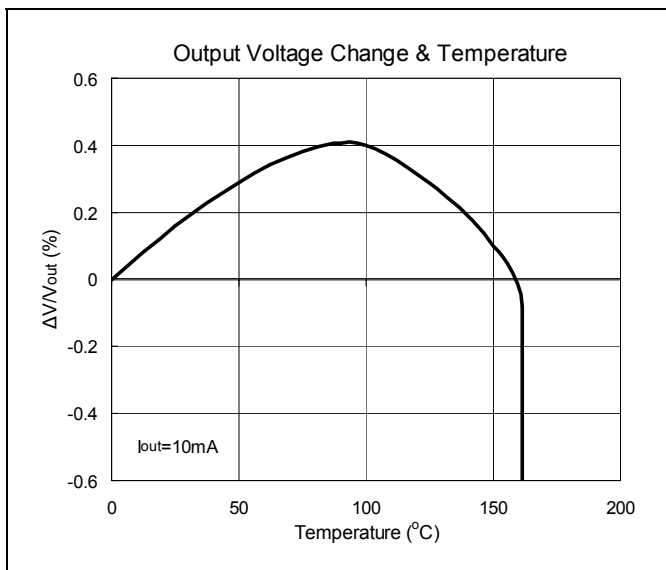
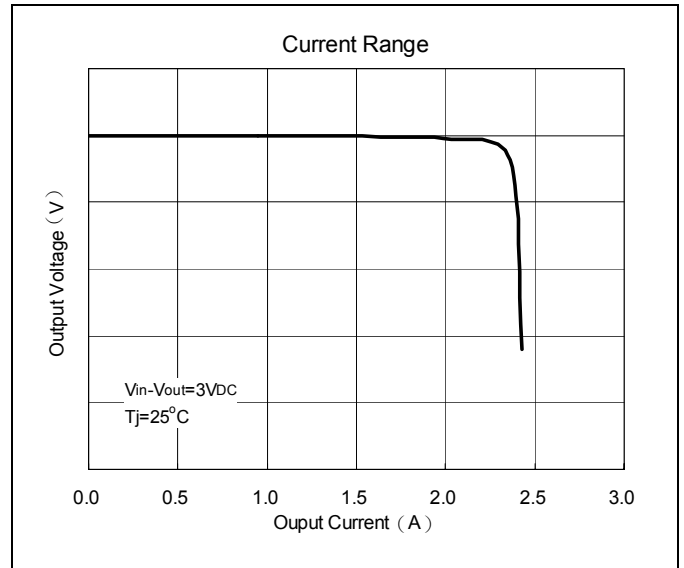
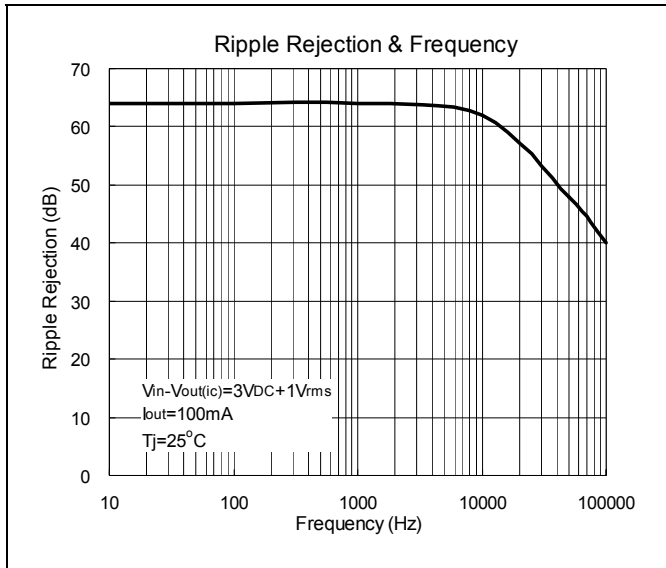



## Applications Description

### • Output Voltage Adjustment

Like most regulators, H1117 series regulate the output by comparing the output voltage to an internally generated reference voltage. On the adjustable version, the  $V_{REF}$  is available externally as 1.25V between  $V_{OUT}$  and ADJ. The voltage ratio formed by  $R_1$  and  $R_2$  should be set to conduct 10mA (minimum output load). The output voltage is given by the following equation:  $V_{OUT} = V_{REF} (1 + R_2/R_1) + I_{ADJ} R_2$ . On fixed versions of H1117 series, the voltage divider is provided internally.

### • Thermal Protection

H1117 series have thermal protection which limits junction temperature to 150°C. However, device functionality is only guaranteed to a maximum junction temperature of +125°C. The power dissipation and junction temperature for H1117 in all packages given by

$$P_D = (V_{IN} - V_{OUT}) I_{OUT}, T_{JUNCTION} = T_{AMBIENT} + (P_D \times \theta_{JA}), \text{ Note: } T_{JUNCTION} \text{ must not exceed } 125^\circ\text{C}$$

### • Current Limit Protection

H1117 series are protected against overload conditions. Current protection is triggered at typically 1.5A.

### • Stability And Load Regulation

H1117 series require a capacitor from  $V_{OUT}$  to GND to provide compensation feedback to the internal gain stage. This is to ensure stability at the output terminal. Typically, a 10uF tantalum or 50uF aluminum electrolytic is sufficient.

Note : It is important that the ESR for this capacitor does not exceed 0.5Ω.

The output capacitor does not have a theoretical upper limit and increasing its value will increase stability.  $C_{OUT} = 100 \mu\text{F}$  or more is typical for high current regulator design.

H1117 series load regulation are limited by the resistance of the wire connecting it to the load ( $R_p$ ). For the adjustable version, the best load regulation is accomplished when the top of the resistor divider ( $R_1$ ) is connected directly to the output pin of the H1117 series. When so connected,  $R_p$  is not multiplied by the divider ratio. For fixed output versions, the top of  $R_1$  is internally connected to the output and ground pin can be connected to low side of the load as a negative side sense if, so desired.

### • Thermal Consideration

The H1117 series contain thermal limiting circuitry designed to protect itself for over-temperature conditions. Even for normal load conditions, maximum junction temperature ratings must not be exceeded. As mention in thermal protection section, we need to consider all sources of thermal resistance between junction and ambient. It contains junction-to-case, case-to-heat-sink interface and heat sink resistance itself. An additional heat sink is applied externally sometimes. It can increase the maximum power dissipation. For example, the equivalent junction temperature of 300mA output current is 115°C without external heat sink. Under the same junction temperature IC can operates 500mA with an adequate heat sink. Therefore, to attach an extra heat sink is recommended.

Junction-to-case thermal resistance is specified from the IC junction to the bottom of the case directly below the die. The bonding wires are appending paths. The former is the lowest resistance path. Proper mounting is required to ensure the best possible thermal flow this area of the package to the heat sink. Thermal compound at the case-to-heat-sink interface is strongly recommended. The case of all devices in this series is electrically connected to the output. Therefore, if the case of the device must be electrically isolated, a thermally conductive spacer can be used, as long its thermal resistance is considered.

### • Protection Diode

(The figure is shown as Regulator with Reverse Diode Protection in advanced applications)

In general operation, H1117 series don't need any protection diodes. From the cross-section structure of H1117 sries, the output pin is connected to P+ substrate, and the input pin is connected to N- well. There is a parasitic reverse diode between them. It can handle microsecond surge currents of 5A to 10A. Even with large output capacitance, it is very difficult to get those values of surge currents in normal operation. Only with high value output capacitors, such as 1000uF. And with the input pin instantaneously shorted to ground. can damage occur. A crowbar circuit at the input of the H1117 series can generate those kinds of currents, and a diode from output to input is recommended. Normal power supply cycling or even plugging and unplugging in the system will not generate currents large enough to do any damage.

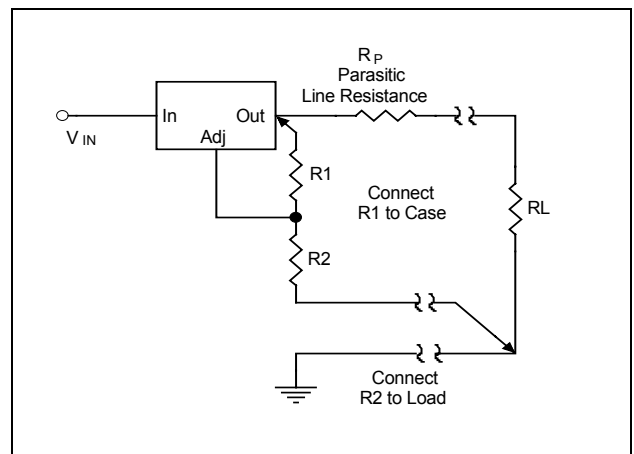
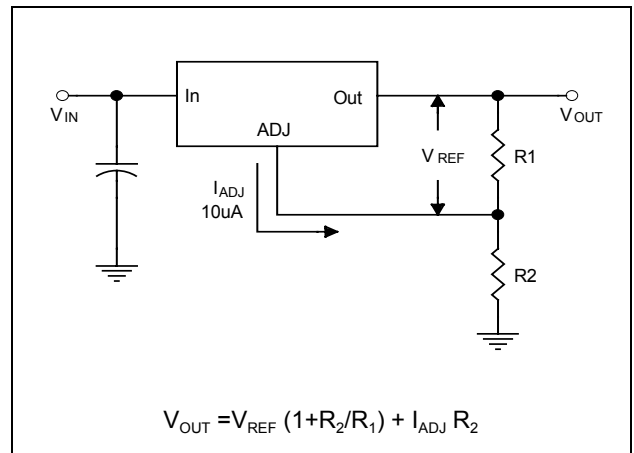



### SOT-223 Dimension

**Marking:**

Pb Free Mark  
 Pb-Free: "●" (Note)  
 Normal: None

Product Series  
(ADJ,1.8,2.5,3.3,5)

Date Code      Control Code

Note: Green label is used for pb-free packing

Pin Style: 1.ADJ/GND 2.VOUT 3.VIN

**Material:**

- Lead solder plating: Sn60/Pb40 (Normal), Sn/3.0Ag/0.5Cu or Pure-Tin (Pb-free)
- Mold Compound: Epoxy resin family, flammability solid burning class: UL94V-0

DIM	Min.	Max.
A	2.90	3.10
B	6.70	7.30
C	3.30	3.70
D	0.60	0.80
E	*2.30	-
F	6.30	6.70
G	1.40	1.80
H	0.25	0.35
I	0.02	0.10
a1	*13°	-
a2	0°	10°

\*: Typical, Unit: mm

3-Lead SOT-223 Plastic  
Surface Mounted Package  
HSMC Package Code: SJ

### SOT-89 Dimension

**Marking:**

Date Code      Control Code

Pb Free Mark  
 Pb-Free: "●" (Note)  
 Normal: None

Product Series  
 ADJ(A),1.8(B),2.5(C),3.3(D),5(E)

Note: Green label is used for pb-free packing

Pin Style: 1.ADJ/GND 2.VOUT 3.VIN

**Material:**

- Lead solder plating: Sn60/Pb40 (Normal), Sn/3.0Ag/0.5Cu or Pure-Tin (Pb-free)
- Mold Compound: Epoxy resin family, flammability solid burning class: UL94V-0

DIM	Min.	Max.
A	4.40	4.60
B	4.05	4.25
C	1.50	1.70
D	2.40	2.60
E	0.36	0.51
F	*1.50	-
G	*3.00	-
H	1.40	1.60
I	0.35	0.41

\*: Typical, Unit: mm

3-Lead SOT-89 Plastic  
Surface Mounted Package  
HSMC Package Code: M



### TO-252 Dimension

3-Lead TO-252 Plastic  
Surface Mount Package  
HSMC Package Code: J

**Marking:**

Pb Free Mark  
 Pb-Free: \* (Note)  
 Normal: None

**Note:** Green label is used for pb-free packing

**Pin Style:** 1.ADJ/GND 2.VOUT 3.VIN

**Material:**

- Lead solder plating: Sn60/Pb40 (Normal), Sn/3.0Ag/0.5Cu or Pure-Tin (Pb-free)
- Mold Compound: Epoxy resin family, flammability solid burning class: UL94V-0

DIM	Min.	Max.
A	6.35	6.80
C	4.80	5.50
F	1.30	1.70
G	5.40	6.25
H	2.20	3.00
L	0.40	0.90
M	2.20	2.40
N	0.90	1.50
a1	0.40	0.65
a2	-	*2.30
a5	0.65	1.05

\*: Typical, Unit: mm

3-Lead TO-252 Plastic  
Surface Mount Package  
HSMC Package Code: J

**Marking:**

Pb Free Mark  
 Pb-Free: \* (Note)  
 Normal: None

**Note:** Green label is used for pb-free packing

**Pin Style:** 1.ADJ/GND 2.VOUT 3.VIN

**Material:**

- Lead solder plating: Sn60/Pb40 (Normal), Sn/3.0Ag/0.5Cu or Pure-Tin (Pb-free)
- Mold Compound: Epoxy resin family, flammability solid burning class: UL94V-0

DIM	Min.	Max.
A	6.40	6.80
B	-	6.00
C	5.04	5.64
D	-	*4.34
E	0.40	0.80
F	0.50	0.90
G	5.90	6.30
H	2.50	2.90
I	9.20	9.80
J	0.60	1.00
K	-	0.96
L	0.66	0.86
M	2.20	2.40
N	0.70	1.10
O	0.82	1.22
a1	0.40	0.60
a2	2.10	2.50
y1	-	5°
y2	-	3°

\*: Typical, Unit: mm



### TO-220AB Dimension

3-Lead TO-220AB  
 Plastic Package  
 HSMC Package Code: E

**Marking:**

Pb Free Mark  
 Pb-Free: \* (Note)  
 Normal: None

Date Code

Product Series  
 ADJ(A), 1.8(B), 2.5(C)  
 3.3(D), 5(E)

Control Code

Note: Green label is used for pb-free packing

Pin Style: 1.ADJ/GND 2(Tab).VOUT 3.VIN

Material:

- Lead solder plating: Sn60/Pb40 (Normal), Sn/3.0Ag/0.5Cu or Pure-Tin (Pb-free)
- Mold Compound: Epoxy resin family, flammability solid burning class: UL94V-0

DIM	Min.	Max.
A	5.58	7.49
B	8.38	8.90
C	4.40	4.70
D	1.15	1.39
E	0.35	0.60
F	2.03	2.92
G	9.66	10.28
H	-	*16.25
I	-	*3.83
J	3.00	4.00
K	0.75	0.95
L	2.54	3.42
M	1.14	1.40
N	-	*2.54
O	12.70	14.27
P	14.48	15.87

\*: Typical, Unit: mm

#### Important Notice:

- All rights are reserved. Reproduction in whole or in part is prohibited without the prior written approval of HSMC.
- HSMC reserves the right to make changes to its products without notice.
- **HSMC semiconductor products are not warranted to be suitable for use in Life-Support Applications, or systems.**
- HSMC assumes no liability for any consequence of customer product design, infringement of patents, or application assistance.

#### Head Office And Factory:

- **Head Office** (Hi-Sincerity Microelectronics Corp.): 10F., No. 61, Sec. 2, Chung-Shan N. Rd. Taipei Taiwan R.O.C.  
 Tel: 886-2-25212056 Fax: 886-2-25632712, 25368454
- **Factory 1:** No. 38, Kuang Fu S. Rd., Fu-Kou Hsin-Chu Industrial Park Hsin-Chu Taiwan. R.O.C  
 Tel: 886-3-5983621~5 Fax: 886-3-5982931



### Soldering Methods for HSMC's Products

1. Storage environment: Temperature=10°C~35°C Humidity=65%±15%
2. Reflow soldering of surface-mount devices

Figure 1: Temperature profile

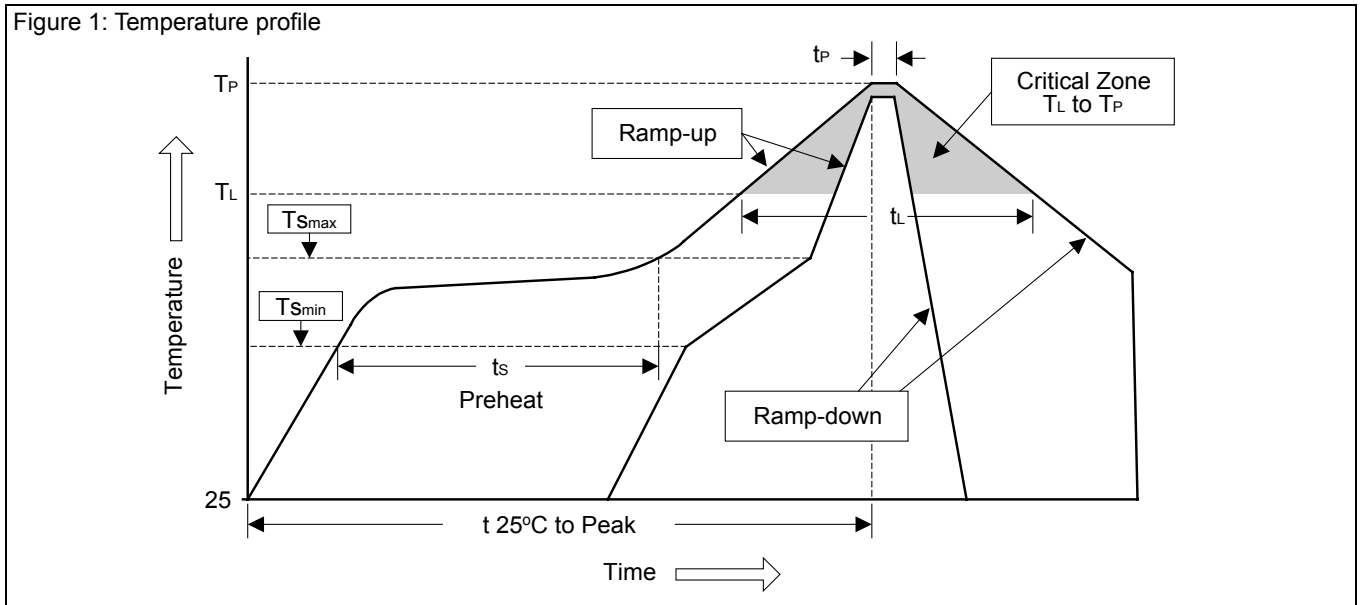

Profile Feature	Sn-Pb Eutectic Assembly	Pb-Free Assembly
Average ramp-up rate ( $T_L$ to $T_P$ )	<3°C/sec	<3°C/sec
Preheat		
- Temperature Min ( $T_{Smin}$ )	100°C	150°C
- Temperature Max ( $T_{Smax}$ )	150°C	200°C
- Time (min to max) ( $t_s$ )	60~120 sec	60~180 sec
$T_{Smax}$ to $T_L$		
- Ramp-up Rate	<3°C/sec	<3°C/sec
Time maintained above:		
- Temperature ( $T_L$ )	183°C	217°C
- Time ( $t_L$ )	60~150 sec	60~150 sec
Peak Temperature ( $T_P$ )	240°C +0/-5°C	260°C +0/-5°C
Time within 5°C of actual Peak Temperature ( $t_p$ )	10~30 sec	20~40 sec
Ramp-down Rate	<6°C/sec	<6°C/sec
Time 25°C to Peak Temperature	<6 minutes	<8 minutes

### 3. Flow (wave) soldering (solder dipping)

Products	Peak temperature	Dipping time
Pb devices.	245°C ±5°C	5sec ±1sec
Pb-Free devices.	260°C +0/-5°C	5sec ±1sec