



# H288

Complementary Output Hall Effect Sensor IC

## Description

H288 is designed to integrate Hall sensor with output driver together on the same chip. It is suitable for dual coils brush-less DC motors, dual coils brush-less DC Fan, Speed measurement, and revolution counting.

It includes a bandgap reference voltage source, a Hall device, a amplifier, a Hysteresis controller and a open-collector output drive capable of sinking up to 300mA current load. An on-chip protection diode is implemented to prevent reverse power fault.

H288 has a control circuit to prevent "dead angle" from logic race condition in DC Fan. It has excellent characteristic of temperature compensation. The internal temperature compensated voltage source can let sensor to get uniform sensitivity in a wide temperature range.

It is rated for operation over temperature range from -20oC to +85oC and voltage ranges from 3.0V to 20V.

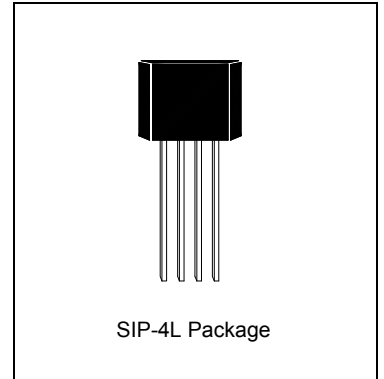

## Features

- On-chip Hall sensor
- 3.0V to 20V operating voltage
- Internal Temperature compensation
- Special design providing logic race condition immunity, shorter switching time, and good switch reliability
- 300mA output sink current
- Internal on-chip protection diode
- SIP-4L Package

## Applications

- Dual-coil Brush-less DC Motor
- Dual-coil Brush-less DC Fan
- Revolution Counting
- Speed Measurement

## Pin Assignment

Name	P/I/O	Pin #	Description
VCC	P	1	Power Supply Input
DO	O	2	Output Pin
DOB	O	3	Output Pin
GND	P	4	Ground

## Typical Application Circuit (Brush-Less DC Fan)

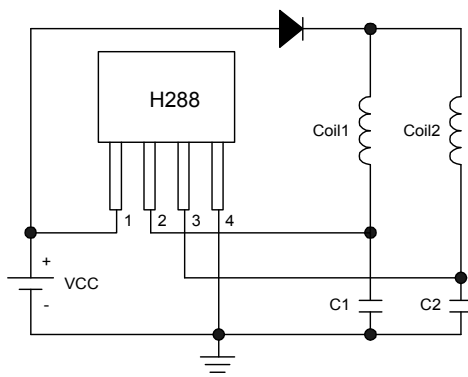



### Block Diagram

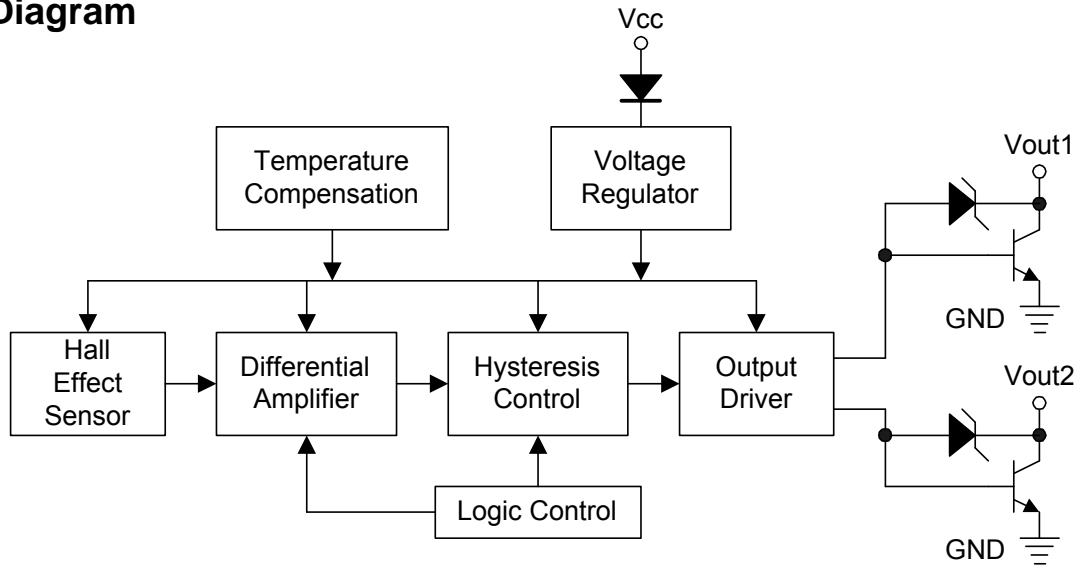

### Test Circuit

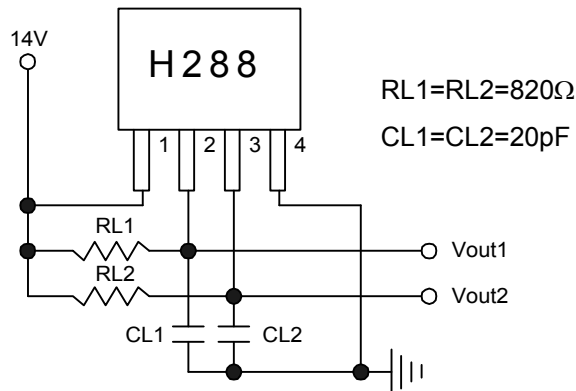

### Absolute Maximum Ratings (Ta=25°C)

Characteristics	Symbol	Values	Unit
Supply Voltage	V <sub>CC</sub>	20	V
Output breakdown Voltage	V <sub>OUT(breakdown)</sub>	35	V
Magnetic Flux Density	B	Unlimited	
Output Zener Breakdown	V <sub>Z</sub>	28	V
Output ON Current (continuous)	I <sub>C</sub>	300	mA
Maximum Output Current	I <sub>C(MAX)</sub>	1	A
Operating Temperature Range	T <sub>A</sub>	-20 to +85	°C
Storage Temperature Range	T <sub>S</sub>	-65 to +150	°C
Package Power Dissipation	P <sub>D</sub>	500	mW
Maximum Junction Temperature	T <sub>J</sub>	175	°C



### Electrical Characteristics (T=+25°C, V<sub>CC</sub>=3V~20V)

Characteristic	Symbol	Test Conditions	Min.	Typ.	Max.	Units
Supply Voltage	V <sub>CC</sub>		3	-	20	V
Output Saturation Voltage	V <sub>CE(sat)</sub>	V <sub>CC</sub> =3V, I <sub>L</sub> =100mA	-	200	-	mV
		V <sub>CC</sub> =14V, I <sub>L</sub> =300mA	-	300	600	
Output Leakage Current	I <sub>ceX</sub>	V <sub>ce</sub> =14V, V <sub>CC</sub> =14V	-	-	2	μA
Supply Current	I <sub>ccQ</sub>	V <sub>CC</sub> =20V, Output Open	-	10	18	mA
Output Rise Time	T <sub>r</sub>	V <sub>CC</sub> =14V, R <sub>L</sub> =400Ω, C <sub>L</sub> =20pF	-	1	5	μS
Output Falling Time	T <sub>f</sub>	V <sub>CC</sub> =14V, R <sub>L</sub> =400Ω, C <sub>L</sub> =20pF	-	0.2	1.2	μS

### Magnetic Characteristics

#### A Grade

Characteristic	Symbol	Min.	Typ.	max.	Units
Operate Point	B <sub>OP</sub>	-	-	70	G
Release Point	B <sub>rp</sub>	-70	-	-	G
Hysteresis window	B <sub>hy</sub>	-	70	-	G

#### B Grade

Characteristic	Symbol	Min.	Typ.	max.	Units
Operate Point	B <sub>OP</sub>	-	-	90	G
Release Point	B <sub>rp</sub>	-90	-	-	G
Hysteresis window	B <sub>hy</sub>	-	70	-	G

#### C Grade

Characteristic	Symbol	Min.	Typ.	max.	Units
Operate Point	B <sub>OP</sub>	-	-	130	G
Release Point	B <sub>rp</sub>	-130	-	-	G
Hysteresis window	B <sub>hy</sub>	-	70	-	G



H288 Hysteresis Characteristics curve

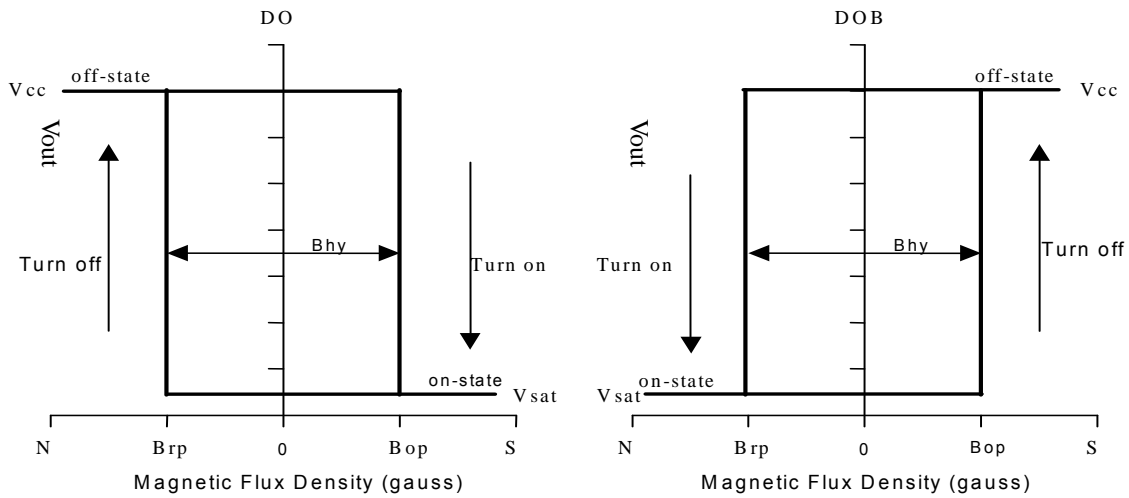

### Characteristics Curve

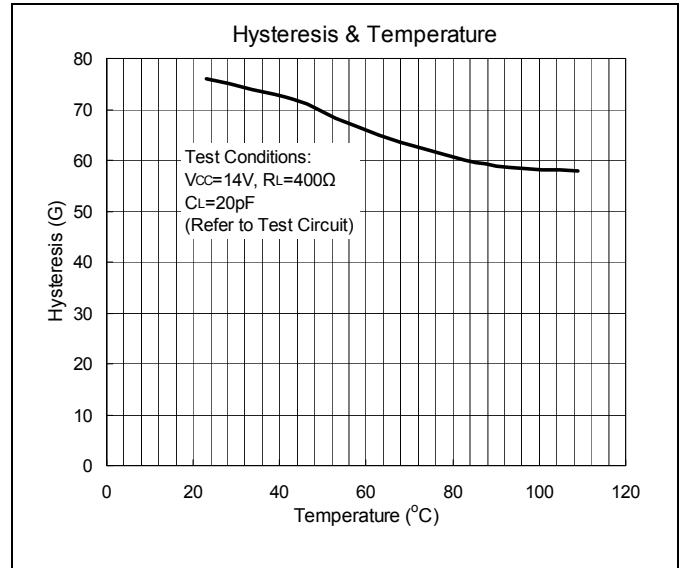
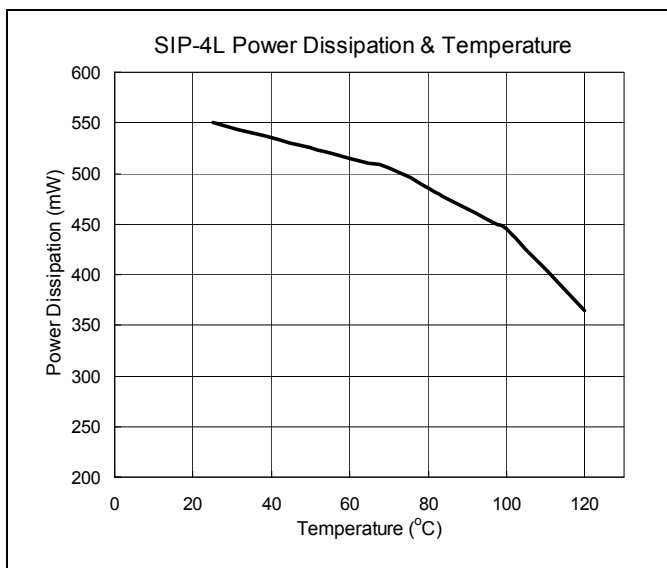
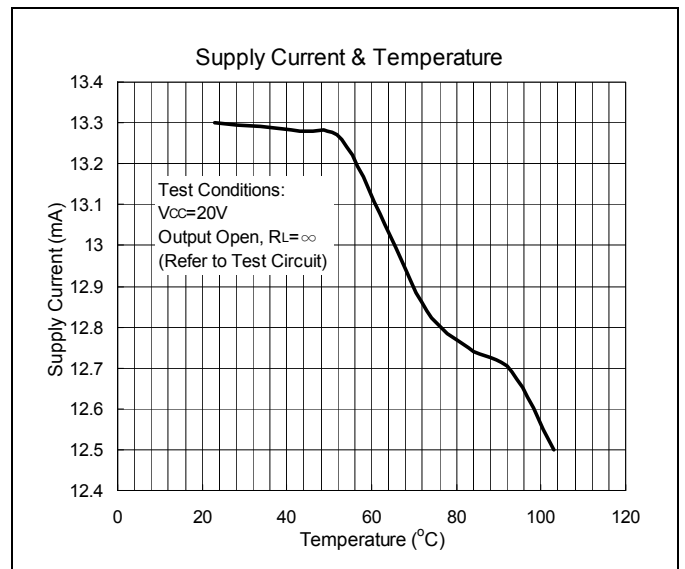
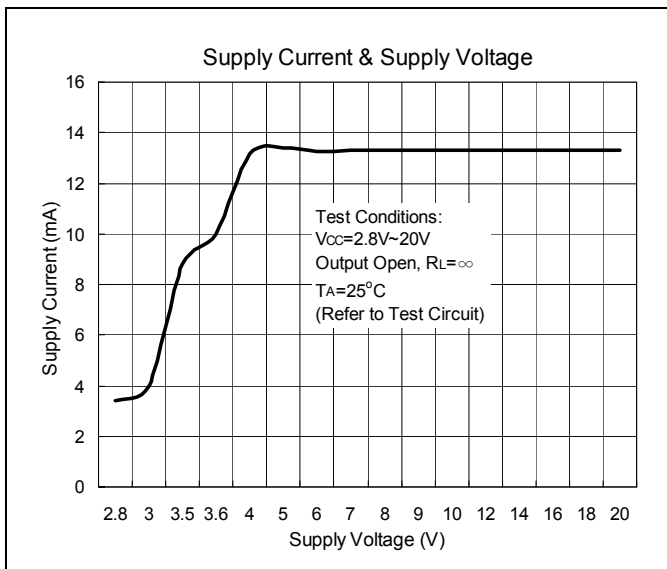

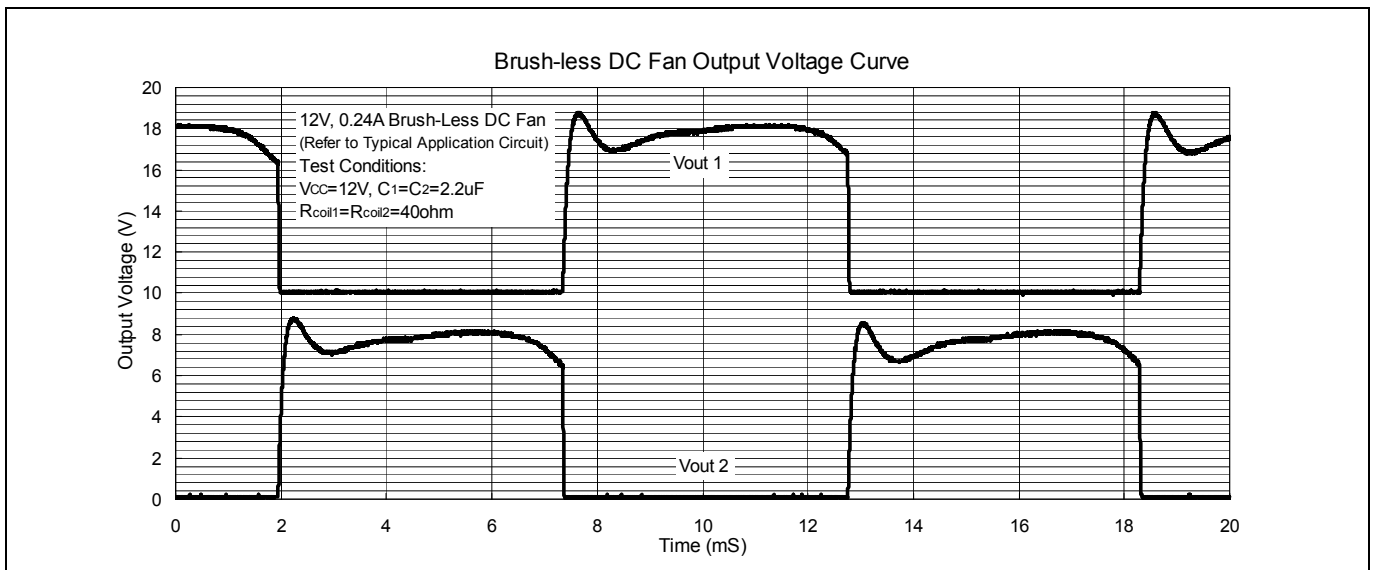
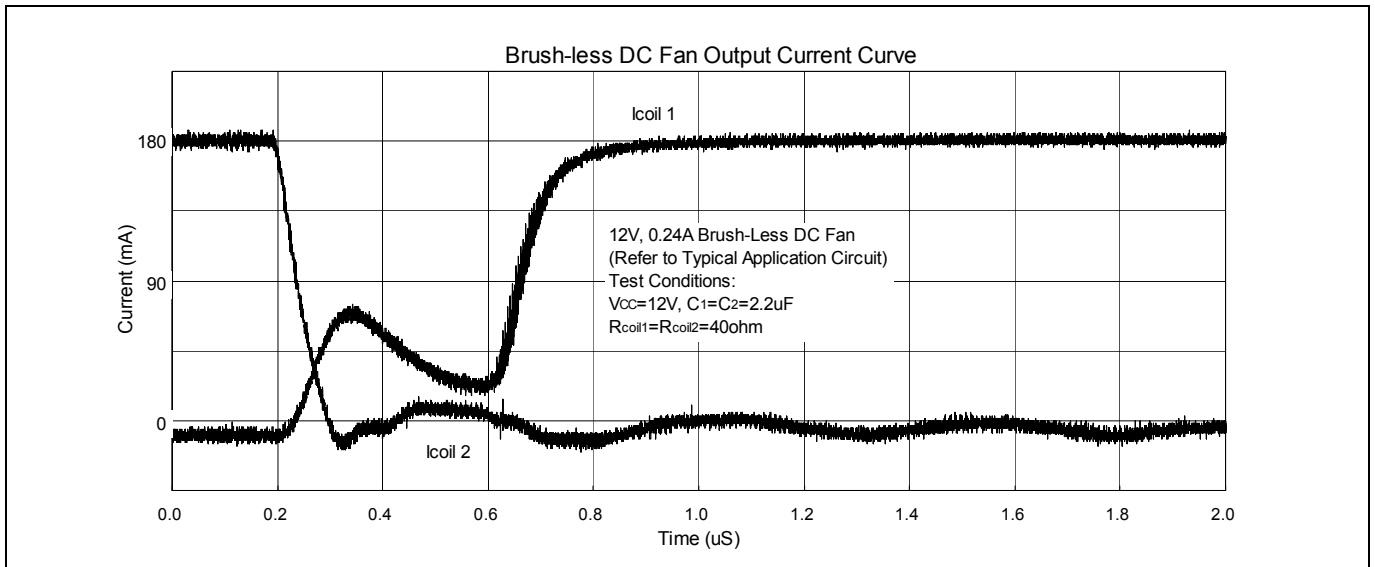



### SIP-4L Dimension

4-Lead SIP-4L Plastic  
HSMC Package Code: AD

**Marking:**

Hall Sensor Location Mark

Halogen Free Mark

Pin Style: 1.VCC 2.DO 3.DOB 4.GND

Hall Sensor Location:

**Material:**

- Lead solder plating: Sn/3.0Ag/0.5Cu or Pure-Tin (Pb-free)
- Mold Compound: Epoxy resin family, flammability solid burning class: UL94V-0

DIM	Min.	Max.
A	3.962	4.216
B	2.870	3.124
C	13.60	15.60
D	1.245	1.753
E	0.750REF	
F	0.406	0.508
G	0.330	0.432
H	1.27REF	
I	1.87	2.13
J	1.27	1.53

\*: Typical, Unit: mm

#### Important Notice:

- All rights are reserved. Reproduction in whole or in part is prohibited without the prior written approval of AVANTIC.
- HSMC reserves the right to make changes to its products without notice.
- HSMC **semiconductor products are not warranted to be suitable for use in Life-Support Applications, or systems.**
- HSMC assumes no liability for any consequence of customer product design, infringement of patents, or application assistance.

#### Head Office:

- **Head Office** (Hi-Sincerity Microelectronics Corp.): 10F., No. 61, Sec. 2, Chung-Shan N. Rd. Taipei Taiwan R.O.C.  
 Tel: 886-2-25212056 Fax: 886-2-25632712, 25368454
- AVANTICS Microelectronics Corp: No. 255, Cai Lun Rd. Zhangjiang Technology Industrial Park Pudong, Shanghai, China  
 Tel: 86-021-58955599 Fax: 86-021-58558038