



H34063AP / H34063AS

DC-TO-DC CONVERTER INTEGRATE CIRCUIT DEVICES

Description

The H34063A Series is a monolithic control circuit containing the primary functions required for DC-to-DC converters. These devices consist of an internal temperature compensated reference, comparator, controlled duty cycle oscillator with an active current limit circuit, driver and high current output switch. This series was specifically by Hi-Sincerity Microelectronics Corp.

Features

- 3V to 40V Input Voltage Operation
- Internal 1.6A Peak Current Switch
- Internal $\pm 1.8\%$ Reference
- Low Quiescent Current at 1.6mA
- Frequency Operation from 100Hz~100KHz
- Output Voltage Adjustable
- Active Current Limiting
- Step-Up, Step-Down or Inverting Switching Regulators

Pin Connections

	Pin1: Switch Collector (SWC)	Pin5: Comparator Inverting Input (FB)
	Pin2: Switch Emitter (SWE)	Pin6: Voltage Supply (Vcc)
	Pin3: Timing Capacitor (TC)	Pin7: Ipk Sense (Ipk)
	Pin4: Ground (GND)	Pin8: Voltage Driver Collector (DRC)

Absolute Maxium Rating

Parameter	Symbol	Value		Unit
Power Supply Voltage	V_{CC}	40		V
Comparator Input Voltage Range	V_{ir}	-0.3~+40		V
Switch Collector Voltage	$V_{C(SW)}$	40		V
Switch Emitter Voltage	V_{SWE}	40		V
Switch Emitter to Collector Voltage	V_{CE}	40		V
Driver Collector Voltage	$V_{C(DR)}$	40		V
Switch Current	I_{SW}	1.5		A
Power Dissipation at $T_j=20^\circ\text{C}$	P_D	DIP-8	1.25	W
		SO-8	0.625	
Operating Ambient Temperature Range	T_{opr}	-20~+85		$^\circ\text{C}$
Storage Temperature Range	T_{stg}	-65~+150		$^\circ\text{C}$
Operating Junction Temperature	T_{opj}	120		$^\circ\text{C}$
Thermal Resistance Junction-ambient	θ_{JA}	125		$^\circ\text{C/W}$

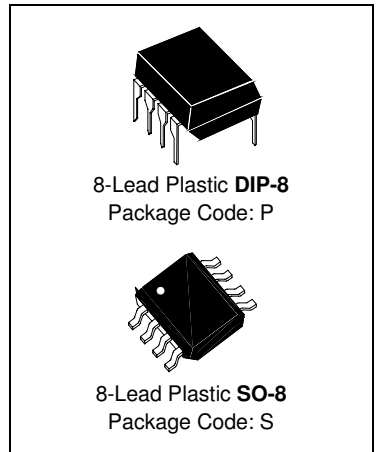



Electrical Characteristics ($V_{CC}=5V, T_A=0\sim 70^\circ C$, unless otherwise specified)

Parameter	Symbol	Test Condition	Min.	Typ.	Max.	Unit
<i>Oscillator</i>						
Charging Current	I_{chg}	$V_{CC}=5\sim 40V, T_a=25^\circ C$	10	25	40	μA
Discharge Current	I_{dischg}	$V_{CC}=5\sim 40V, T_a=25^\circ C$	140	190	240	μA
Frequency	f_{OSC}	$V_{PIN5}=0, C_T=1nF, T_a=25^\circ C$	28	33	40	KHz
Discharge to Charge Current Ratio	I_{dischg}/I_{chg}	$V_{PIN7}=V_{CC}, T_a=25^\circ C$	5.2	6	7.5	
Current Limit Sense Voltage	V_{IPK}	$I_{dischg}=I_{chg}, T_a=25^\circ C$	250	300	350	mV
<i>Output Switch</i>						
Saturation Voltage, Darlington Connection	$V_{CE(sat)1}$	$I_{SW}=1A, V_{C(SW)}=V_{C(DR)}$	-	1	1.3	V
Saturation Voltage	$V_{CE(sat)2}$	$I_{SW}=1A, I_{C(DR)}=50mA$	-	0.4	0.7	V
DC Current Gain	h_{FE}	$I_{SW}=1A, V_{CE}=5V$	35	120	-	
Collector Off-State Current	$I_{CC(off)}$	$V_{CE}=40V, T_a=25^\circ C$	-	10	100	μA
<i>Comparator</i>						
Threshold Voltage	V_{FB}		1.23	1.25	1.27	V
Threshold Voltage Line Regulation	ΔV_{FB}	$V_{CC}=5\sim 40V$	-	1.5	6	mV
Input Bias Current	I_{IB}	$V_{IN}=0V$	-	40	400	nA
<i>Total Device</i>						
Supply Current	I_{CC}	$V_{CC}=5\sim 40V, V_{PIN7}=V_{CC}, V_{PIN5}>V_{FB}, C_T=0.001\mu F, Pin7=GND, \text{Remaining pins open}$	-	1.6	3	mA

Block Diagram

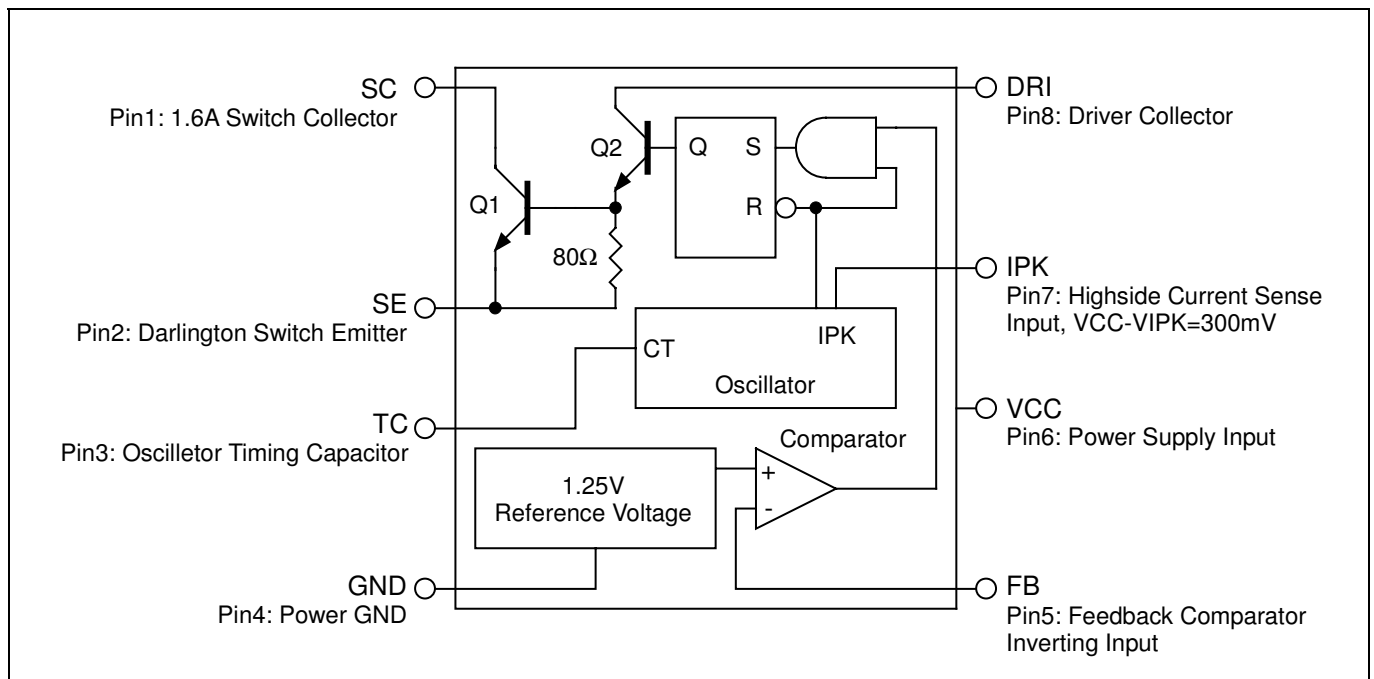



Application Information

Design Formula Table

Calculation	Step-Down	Step-Up	Voltage-Inverting
t_{on}/t_{off}	$(V_{out}+V_F)/(V_{in(min)}-V_{sat}-V_{out})$	$(V_{out}+V_F-V_{in(min)})/(V_{in(min)}-V_{sat})$	$(V_{out} +V_F)/(V_{in(max)}-V_{sat})$
$(t_{on}+t_{off}) \max$	$1/F_{min}$	$1/F_{min}$	$1/F_{min}$
C_T	$4*10^{-5}t_{on}$	$4*10^{-5}t_{on}$	$4*10^{-5}t_{on}$
$I_{C(sw)}$	$2*I_{out(max)}$	$2*I_{out(max)}(t_{on}+t_{off}/t_{off})$	$2*I_{out(max)}(t_{on}+t_{off}/t_{off})$
R_S	$0.3/I_{C(sw)}$	$0.3/I_{C(sw)}$	$0.3/I_{C(sw)}$
$L_{(min)}$	$(V_{in(min)}-V_{sat}/I_{pk(sw)})*t_{on(max)}$	$(V_{in(min)}-V_{sat}/I_{pk(sw)})*t_{on(max)}$	$(V_{in(min)}-V_{sat}/I_{pk(sw)})*t_{on(max)}$
C_O	$(I_{pk(sw)}*(t_{on}+t_{off}))/ (8*V_{ripple(P-P)})$	$I_{out}*t_{on}/V_{ripple(P-P)}$	$I_{out}*t_{on}/V_{ripple(P-P)}$

V_{sat} : Saturation voltage of the output switch.

V_F : Forward voltage drop of the ringback rectifier.

The following power supply characteristics must be chosen:

V_{in} : Nominal input voltage.

V_{out} : Desired output voltage. $|V_{out}|=1.25*(1+RB/RA)$

I_{out} : Desired output current

F_{min} : Minimum desired output switching frequency at the selected values for V_{in} and I_{out} .

$V_{ripple(P-P)}$: Desired peak to peak output ripple voltage in practice, the calculated value will need to be increased due to the capacitor equivalent series resistance and board layout. The ripple voltage should be kept to a low value since it will directly effect the line and load regulation.



Application Information (Continuos)

Fig.2 Step-Up Converter

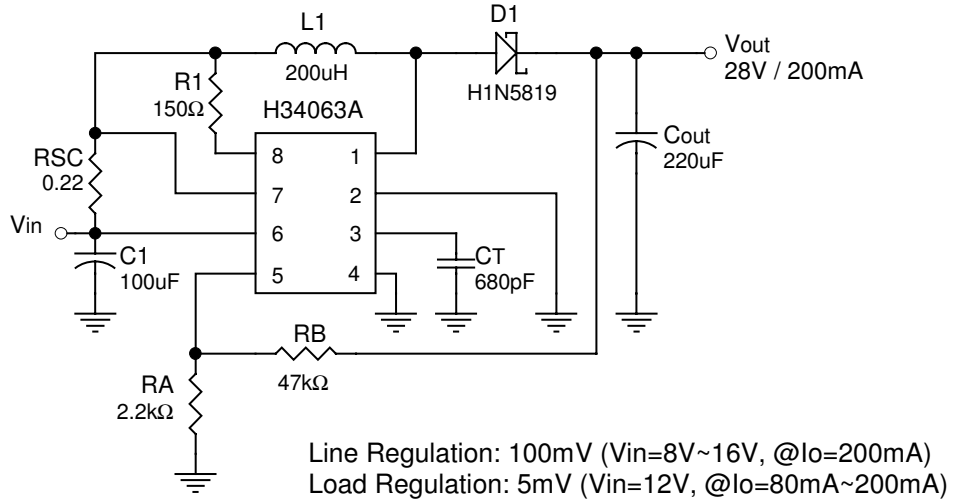

Fig.3 Step-Up Converter With External NPN Switch

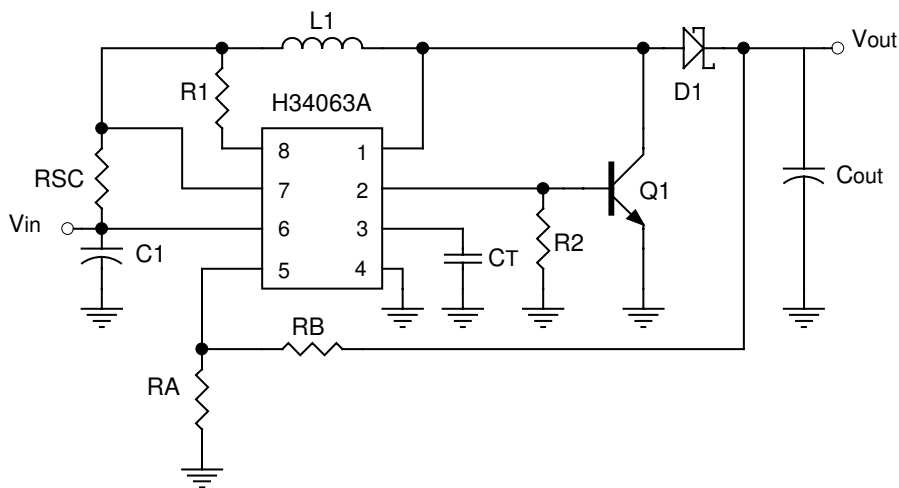

Fig.4 Step-Down Converter

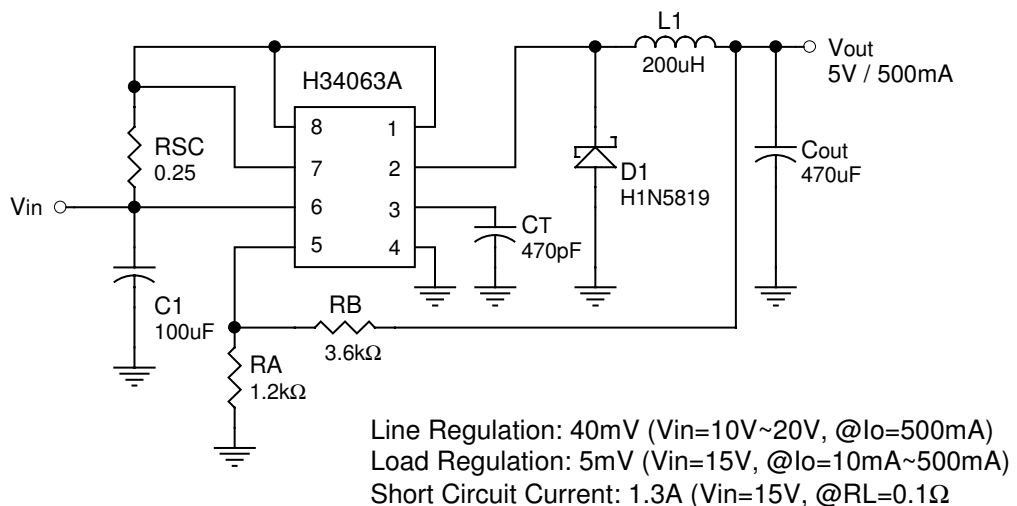



Fig.5 Step-Down Converter With External PNP Saturation Switch

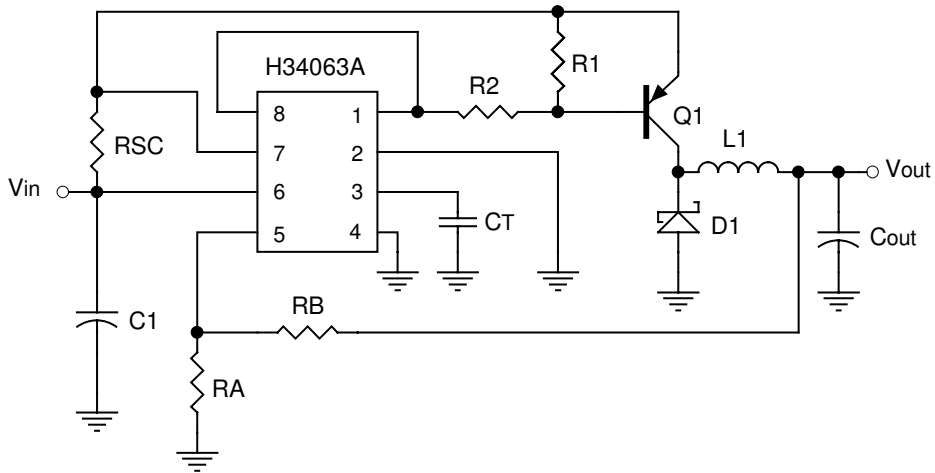

Fig.6 Voltage Inverting Converter

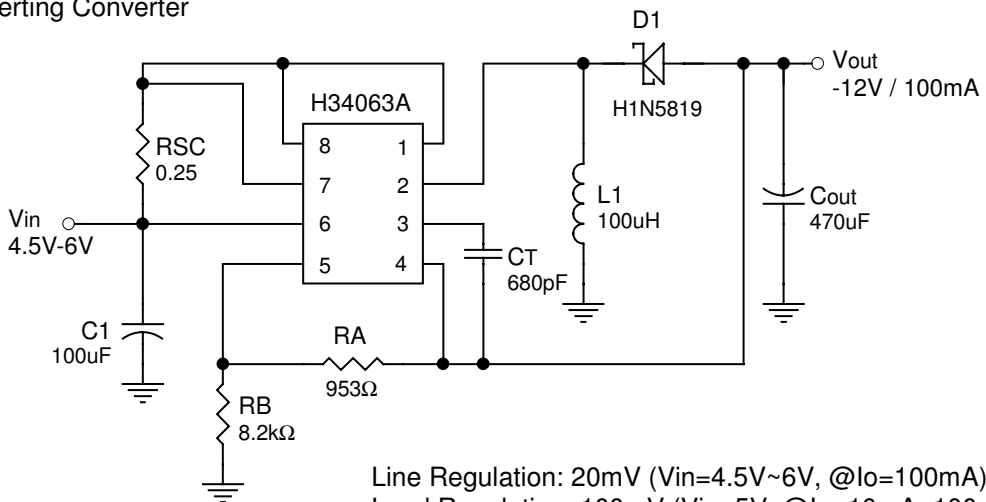
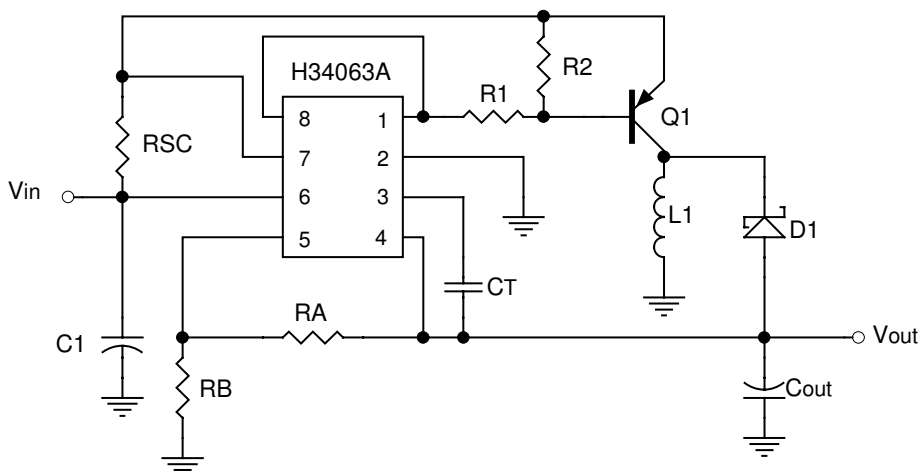

Fig.7 Voltage Inverting Converter With External PNP Saturation Switch





DIP-8 Dimension

8-Lead DIP-8
Plastic Package
HSMC Package Code: P

Marking:

Pb Free Mark
Pb-Free: " " (Note)
Normal: None

Date Code Control Code

Note: Green label is used for pb-free packing

Pin Style: 1.SWC 2.SWE 3.TC 4.GND
5.FB 6.VCC 7.lpk 8.DRC

Material:

- Lead solder plating: Sn60/Pb40 (Normal), Sn/3.0Ag/0.5Cu or Pure-Tin (Pb-free)
- Mold Compound: Epoxy resin family, flammability solid burning class: UL94V-0

DIM	Min.	Max.
A	6.29	6.40
B	9.22	9.32
C	-	*1.52
D	-	*1.27
E	-	*0.99
F	3.25	3.35
G	3.17	3.55
H	0.38	0.53
I	2.28	2.79
J	7.49	7.74
K	-	*3.00
L	8.56	8.81
M	0.229	0.381
$\alpha 1$	94°	97°

*: Typical, Unit: mm

SO-8 Dimension

8-Lead SO-8 Plastic
Surface Mounted Package
HSMC Package Code: S

Marking:

Pb Free Mark
Pb-Free: " " (Note)
Normal: None

Pin 1 Index
Date Code Control Code

Note: Green label is used for pb-free packing

Pin Style: 1.SWC 2.SWE 3.TC 4.GND
5.FB 6.VCC 7.lpk 8.DRC

Material:

- Lead solder plating: Sn60/Pb40 (Normal), Sn/3.0Ag/0.5Cu or Pure-Tin (Pb-free)
- Mold Compound: Epoxy resin family, flammability solid burning class: UL94V-0

DIM	Min.	Max.
A	4.85	5.10
B	3.85	3.95
C	5.80	6.20
D	1.22	1.32
E	0.37	0.47
F	3.74	3.88
G	1.45	1.65
H	4.80	5.10
I	0.05	0.20
J	0.30	0.70
K	0.19	0.25
L	0.37	0.52
M	0.23	0.28
N	0.08	0.13
O	0.00	0.15

*: Typical, Unit: mm

Important Notice:

- All rights are reserved. Reproduction in whole or in part is prohibited without the prior written approval of HSMC.
- HSMC reserves the right to make changes to its products without notice.
- **HSMC semiconductor products are not warranted to be suitable for use in Life-Support Applications, or systems.**
- HSMC assumes no liability for any consequence of customer product design, infringement of patents, or application assistance.

Head Office And Factory:

- **Head Office** (Hi-Sincerity Microelectronics Corp.): 10F., No. 61, Sec. 2, Chung-Shan N. Rd. Taipei Taiwan R.O.C.
Tel: 886-2-25212056 Fax: 886-2-25632712, 25368454
- **Factory 1:** No. 38, Kuang Fu S. Rd., Fu-Kou Hsin-Chu Industrial Park Hsin-Chu Taiwan. R.O.C
Tel: 886-3-5983621~5 Fax: 886-3-5982931



Soldering Methods for HSMC's Products

1. Storage environment: Temperature=10°C~35°C Humidity=65%±15%
2. Reflow soldering of surface-mount devices

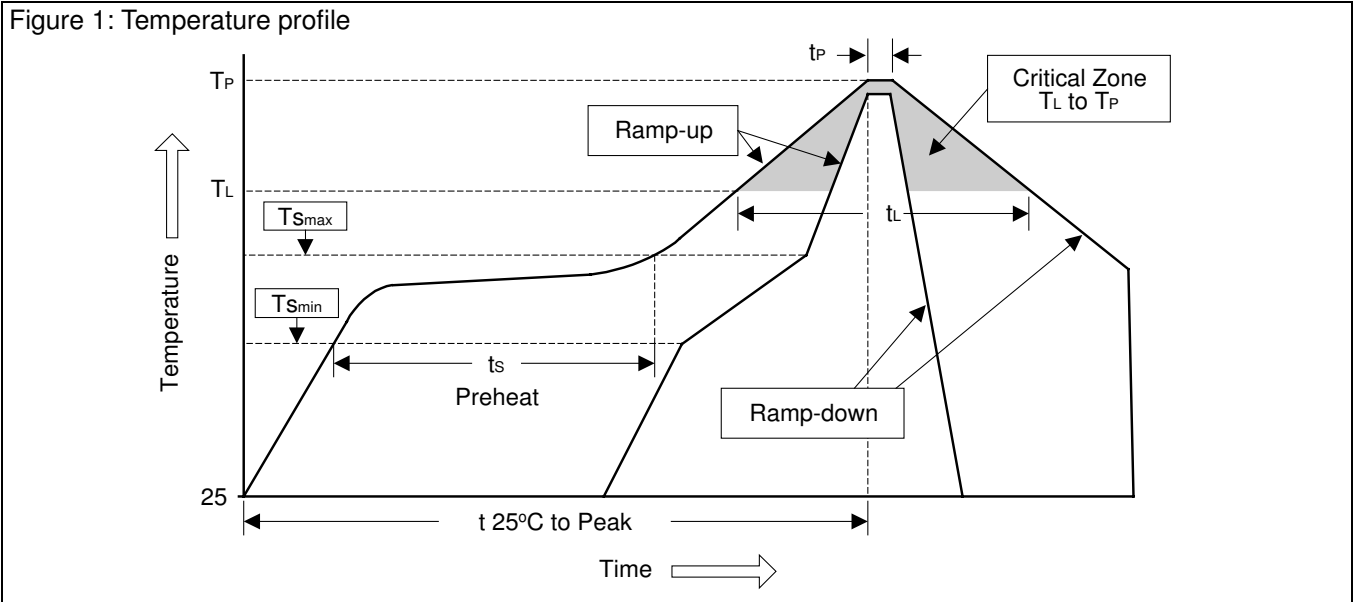

Profile Feature	Sn-Pb Eutectic Assembly	Pb-Free Assembly
Average ramp-up rate (T_L to T_P)	<3°C/sec	<3°C/sec
Preheat		
- Temperature Min (T_{smin})	100°C	150°C
- Temperature Max (T_{smax})	150°C	200°C
- Time (min to max) (t_s)	60~120 sec	60~180 sec
T_{smax} to T_L		
- Ramp-up Rate	<3°C/sec	<3°C/sec
Time maintained above:		
- Temperature (T_L)	183°C	217°C
- Time (t_L)	60~150 sec	60~150 sec
Peak Temperature (T_P)	240°C +0/-5°C	260°C +0/-5°C
Time within 5°C of actual Peak Temperature (t_P)	10~30 sec	20~40 sec
Ramp-down Rate	<6°C/sec	<6°C/sec
Time 25°C to Peak Temperature	<6 minutes	<8 minutes

3. Flow (wave) soldering (solder dipping)

Products	Peak temperature	Dipping time
Pb devices.	245°C ±5°C	10sec ±1sec
Pb-Free devices.	260°C ±5°C	10sec ±1sec