



H8205A

Dual N-Channel Enhancement-Mode MOSFET (20V, 6A)

Description

This N-Channel 2.5V specified MOSFET is a rugged gate version of advanced trench process. It has been optimized for power management applications with a wide range of gate drive voltage (2.5V-10V)

Features

- $R_{DS(on)}=40m\Omega@V_{GS}=2.5V, I_D=5.2A$; $R_{DS(on)}=25m\Omega@V_{GS}=4.5V, I_D=6A$
- High Density Cell Design for Ultra Low On-Resistance
- High Power and Current Handling Capability
- Fully Characterized Avalanche Voltage and Current
- Ideal for Li ion Battery Pack Applications

Applications

- Battery Protection
- Load Switch
- Power Management

Absolute Maximum Ratings (T_A=25°C, unless otherwise noted)

Symbol	Parameter	Ratings	Units
V _{DS}	Drain-Source Voltage	20	V
V _{GS}	Gate-Source Voltage	±8	V
I _D	Drain Current	6	A
I _{DM}	Drain Current (Pulsed) *1	30	A
P _D	Total Power Dissipation @T _A =25°C	1.5	W
	Total Power Dissipation @T _A =75°C	0.96	W
T _j , T _{stg}	Operating and Storage Temperature Range	-55 to +150	°C
R _{θJA}	Thermal Resistance Junction to Ambient *2	83	°C/W

*1: Maximum DC current limited by the package

*2: 1-in² 2oz Cu PCB board

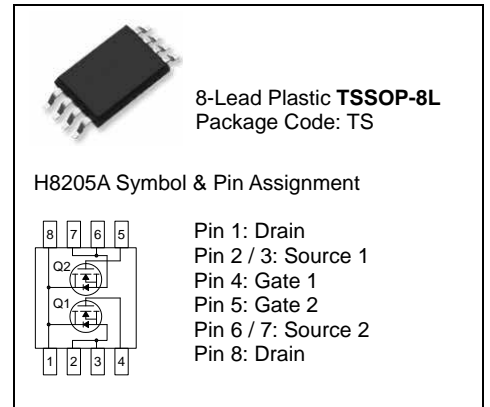



Electrical Characteristics (T_A=25°C, unless otherwise noted)

Symbol	Characteristic	Test Conditions	Min.	Typ.	Max.	Unit
--------	----------------	-----------------	------	------	------	------

• **Static**

BV _{DSS}	Drain-Source Breakdown Voltage	V _{GS} =0V, I _D =250uA	18	20	-	V
R _{DS(on)}	Drain-Source On-State Resistance	V _{GS} =2.5V, I _D =5.2A	-		40	mΩ
		V _{GS} =4.5V, I _D =6A	-		25	
V _{GS(th)}	Gate Threshold Voltage	V _{DS} =V _{GS} , I _D =250uA	0.5	-	1.5	V
I _{DSS}	Zero Gate Voltage Drain Current	V _{DS} =16V, V _{GS} =0V	-	-	1	uA
I _{GSS}	Gate-Body Leakage Current	V _{GS} =±8V, V _{DS} =0V	-	-	±100	nA
g _{FS}	Forward Transconductance	V _{DS} =10V, I _D =6A	7	13	-	S

• **Dynamic**

Q _g	Total Gate Charge	V _{DS} =10V, I _D =6A, V _{GS} =4.5V	-	4.86	-	nC
Q _{gs}	Gate-Source Charge		-	0.92	-	
Q _{gd}	Gate-Drain Charge		-	1.4	-	
C _{iss}	Input Capacitance	V _{DS} =8V, V _{GS} =0V, f=1MHz	-	562	-	pF
C _{oss}	Output Capacitance		-	106	-	
C _{rss}	Reverse Transfer Capacitance		-	75	-	
t _{d(on)}	Turn-on Delay Time	V _{DD} =10V, I _D =1A, V _{GS} =4.5V R _{GEN} =6Ω	-	8.1	-	ns
t _r	Turn-on Rise Time		-	9.95	-	
t _{d(off)}	Turn-off Delay Time		-	21.85	-	
t _f	Turn-off Fall Time		-	5.35	-	

• **Drain-Source Diode Characteristics**

I _S	Maximum Diode Forward Current		-	-	1.7	A
V _{SD}	Drain-Source Diode Forward Voltage	V _{GS} =0V, I _S =1.7A	-	-	1.2	V

Note: Pulse Test: Pulse Width ≤300us, Duty Cycle≤2%

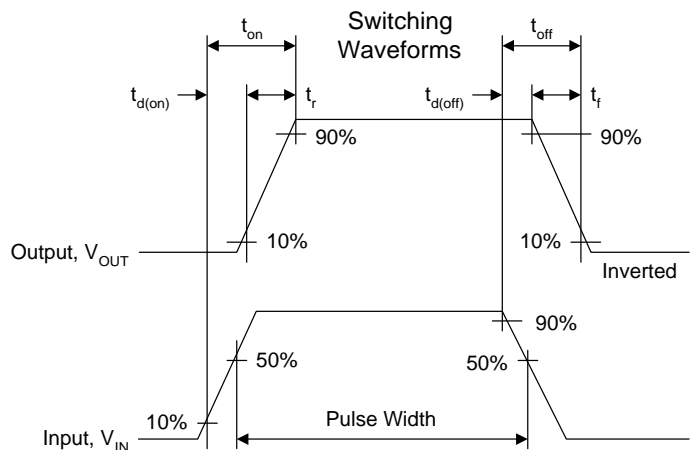
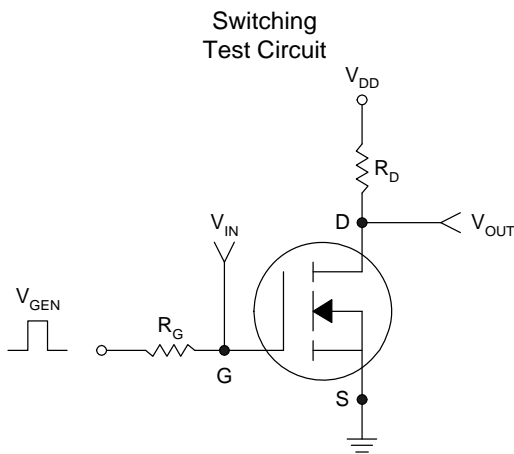



TSSOP-8L Dimension

8-Lead TSSOP-8L Plastic
Surface Mounted Package
HSMC Package Code: TS

H8205A Marking:

Pin Style: 1.S2 2.G2 3.S1 4.G1 5 & 6 & 7 & 8.D

Note: Green label is used for pb-free packing

Material:

- Lead solder plating: Sn60/Pb40 (Normal), Sn/3.0Ag/0.5Cu or Pure-Tin (Pb-free)
- Mold Compound: Epoxy resin family, flammability solid burning class: UL94V-0

DIM	Min.	Max.
A	-	1.20
A1	0.05	0.15
b	0.19	0.3
C	0.09	0.20
D	2.90	3.10
E	6.20	6.60
E1	4.30	4.50
e	0.65 BSC	
L	0.45	0.75
S	0°	8°

*: Typical, Unit: mm

Important Notice:

- All rights are reserved. Reproduction in whole or in part is prohibited without the prior written approval of HSMC.
- HSMC reserves the right to make changes to its products without notice.
- **HSMC semiconductor products are not warranted to be suitable for use in Life-Support Applications, or systems.**
- HSMC assumes no liability for any consequence of customer product design, infringement of patents, or application assistance.

Head Office And Factory:

- **Head Office** (Hi-Sincerity Microelectronics Corp.): 10F., No. 61, Sec. 2, Chung-Shan N. Rd. Taipei Taiwan R.O.C.
Tel: 886-2-25212056 Fax: 886-2-25632712, 25368454
- **Factory 1:** No. 38, Kuang Fu S. Rd., Fu-Kou Hsin-Chu Industrial Park Hsin-Chu Taiwan. R.O.C
Tel: 886-3-5983621~5 Fax: 886-3-5982931



Soldering Methods for HSMC's Products

1. Storage environment: Temperature=10°C~35°C Humidity=65%±15%
2. Reflow soldering of surface-mount devices

Figure 1: Temperature profile

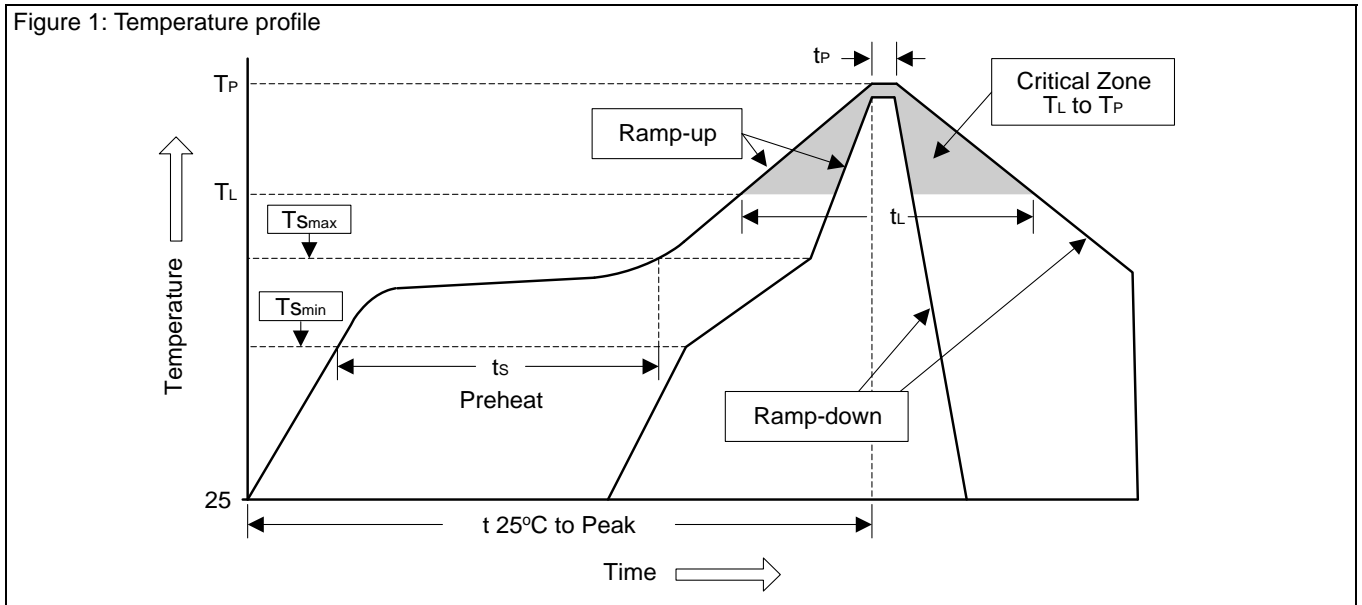

Profile Feature	Sn-Pb Eutectic Assembly	Pb-Free Assembly
Average ramp-up rate (T_L to T_P)	<3°C/sec	<3°C/sec
Preheat		
- Temperature Min (T_{Smin})	100°C	150°C
- Temperature Max (T_{Smax})	150°C	200°C
- Time (min to max) (t_s)	60~120 sec	60~180 sec
T_{Smax} to T_L		
- Ramp-up Rate	<3°C/sec	<3°C/sec
Time maintained above:		
- Temperature (T_L)	183°C	217°C
- Time (t_L)	60~150 sec	60~150 sec
Peak Temperature (T_P)	240°C +0/-5°C	260°C +0/-5°C
Time within 5°C of actual Peak Temperature (t_P)	10~30 sec	20~40 sec
Ramp-down Rate	<6°C/sec	<6°C/sec
Time 25°C to Peak Temperature	<6 minutes	<8 minutes

3. Flow (wave) soldering (solder dipping)

Products	Peak temperature	Dipping time
Pb devices.	245°C ±5°C	5sec ±1sec
Pb-Free devices.	260°C +0/-5°C	5sec ±1sec