

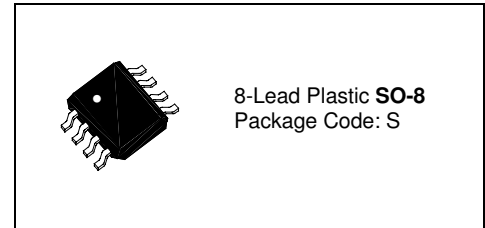

H6968S / H6968CS

Dual N-Channel Enhancement-Mode MOSFET (20V, 6.5A)
 (Battery Switch, ESD Protected)



Features

- $R_{DS(on)}=32m\Omega@V_{GS}=2.5V, I_D=5.5A$
- $R_{DS(on)}=24m\Omega@V_{GS}=4.5V, I_D=6.5A$
- Advanced Trench Process Technology
- High Density Cell Design for Ultra Low On-Resistance
- Specially Designed for Li ion Battery Packs Use
- Designed for Battery Switch Applications
- ESD Protected

Absolute Maximum Ratings ($T_A=25^\circ C$, unless otherwise noted)

Symbol	Parameter	Ratings	Units
V_{DS}	Drain-Source Voltage	20	V
V_{GS}	Gate-Source Voltage	± 12	V
I_D	Drain Current (Continuous)	6.5	A
I_{DM}	Drain Current (Pulsed) *1	30	A
P_D	Total Power Dissipation @ $T_A=25^\circ C$	2	W
	Total Power Dissipation @ $T_A=75^\circ C$	1.3	W
T_j, T_{stg}	Operating and Storage Temperature Range	-55 to +150	$^\circ C$
$R_{\theta JA}$	Thermal Resistance Junction to Ambient (PCB mounted)*2	62.5	$^\circ C/W$

*1: Maximum DC current limited by the package

*2: 1-in² 2oz Cu PCB board

Pin Assignment & Internal Schematic Diagram

Part No.	Pin Assignment	Internal Schematic Diagram
H6968S	<p>Top View</p>	
H6968CS	<p>Top View</p>	



Electrical Characteristics (T_A=25°C, unless otherwise noted)

Symbol	Characteristic	Test Conditions	Min.	Typ.	Max.	Unit
--------	----------------	-----------------	------	------	------	------

• Static

BV _{DSS}	Drain-Source Breakdown Voltage	V _{GS} =0V, I _D =250μA	20	-	-	V
R _{DS(on)}	Drain-Source On-State Resistance	V _{GS} =2.5V, I _D =5.5A	-	24	32	mΩ
		V _{GS} =4.5V, I _D =6.5A	-	20	24	
V _{GS(th)}	Gate Threshold Voltage	V _{DS} =V _{GS} , I _D =250μA	0.6	-	1.6	V
I _{DSS}	Zero Gate Voltage Drain Current	V _{DS} =16V, V _{GS} =0V	-	-	1	μA
I _{GSS}	Gate-Body Leakage Current	V _{GS} =±4.5V, V _{DS} =0V	-	-	±200	nA
g _{FS}	Forward Transconductance	V _{DS} =10V, I _D =6.5A	-	30	-	S

• Dynamic

Q _g	Total Gate Charge	V _{DS} =10V, I _D =6A, V _{GS} =4.5V	-	9	-	nC
Q _{gs}	Gate-Source Charge		-	2.4	-	
Q _{gd}	Gate-Drain Charge		-	3.6	-	
C _{iss}	Input Capacitance	V _{DS} =10V, V _{GS} =0V, f=1MHz	-	476	-	pF
C _{oss}	Output Capacitance		-	65.1	-	
C _{rss}	Reverse Transfer Capacitance		-	49	-	
t _{d(on)}	Turn-on Delay Time	V _{DD} =10V, I _D =1A, V _{GS} =4.5V R _{GEN} =6Ω	-	50	-	ns
t _r	Turn-on Rise Time		-	100	-	
t _{d(off)}	Turn-off Delay Time		-	500	-	
t _f	Turn-off Fall Time		-	200	-	

• Drain-Source Diode Characteristics

I _S	Maximum Diode Forward Current		-	-	1.7	A
V _{SD}	Drain-Source Diode Forward Voltage	V _{GS} =0V, I _S =1.5A	-	0.61	1.2	V

Note: Pulse Test: Pulse Width ≤300us, Duty Cycle ≤2%

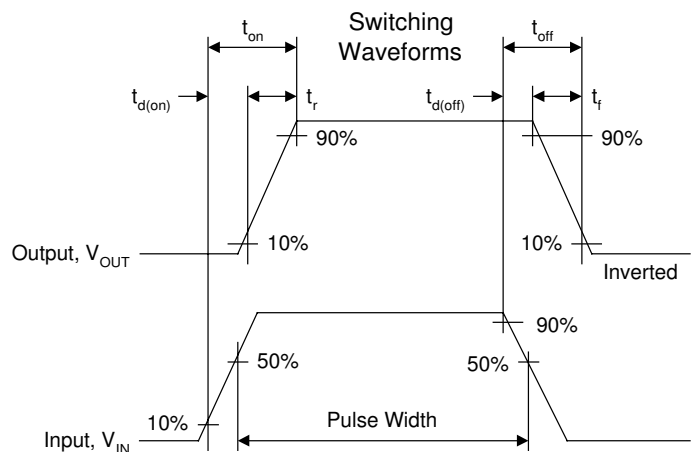
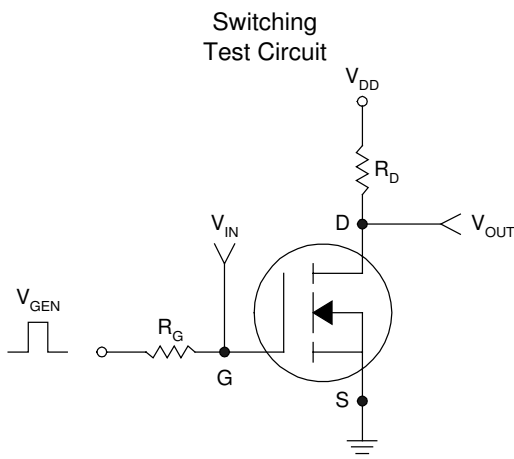



SO-8 Dimension

8-Lead SO-8 Plastic
Surface Mounted Package
HSMC Package Code: S

H6968S Marking:

Pb Free Mark
 Pb-Free: "●" (Note)
 Normal: None

Pin Style: 1.S2 2.G2 3.S1 4.G1 5 & 6.D1 7 & 8.D2

H6968CS Marking:

Pb Free Mark
 Pb-Free: "●" (Note)
 Normal: None

Pin Style: 1.S2 2.G2 3.S1 4.G1 5 & 6 & 7 & 8.D

Note: Green label is used for pb-free packing

Material:

- Lead solder plating: Sn60/Pb40 (Normal), Sn/3.0Ag/0.5Cu or Pure-Tin (Pb-free)
- Mold Compound: Epoxy resin family, flammability solid burning class: UL94V-0

DIM	Min.	Max.
A	4.85	5.10
B	3.85	3.95
C	5.80	6.20
D	1.22	1.32
E	0.37	0.47
F	3.74	3.88
G	1.45	1.65
H	4.80	5.10
I	0.05	0.20
J	0.30	0.70
K	0.19	0.25
L	0.37	0.52
M	0.23	0.28
N	0.08	0.13
O	0.00	0.15

*: Typical, Unit: mm

Important Notice:

- All rights are reserved. Reproduction in whole or in part is prohibited without the prior written approval of HSMC.
- HSMC reserves the right to make changes to its products without notice.
- **HSMC semiconductor products are not warranted to be suitable for use in Life-Support Applications, or systems.**
- HSMC assumes no liability for any consequence of customer product design, infringement of patents, or application assistance.

Head Office And Factory:

- **Head Office** (Hi-Sincerity Microelectronics Corp.): 10F., No. 61, Sec. 2, Chung-Shan N. Rd. Taipei Taiwan R.O.C.
 Tel: 886-2-25212056 Fax: 886-2-25632712, 25368454
- **Factory 1:** No. 38, Kuang Fu S. Rd., Fu-Kou Hsin-Chu Industrial Park Hsin-Chu Taiwan. R.O.C
 Tel: 886-3-5983621~5 Fax: 886-3-5982931



Soldering Methods for HSMC's Products

1. Storage environment: Temperature=10°C~35°C Humidity=65%±15%
2. Reflow soldering of surface-mount devices

Figure 1: Temperature profile

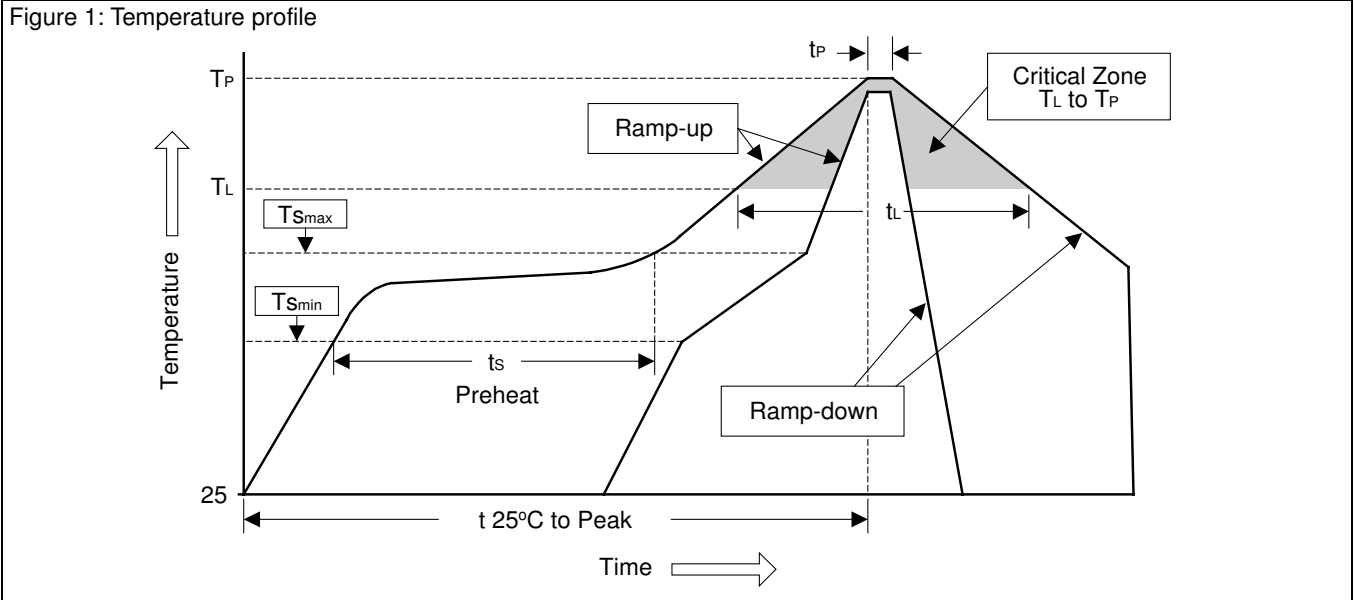

Profile Feature	Sn-Pb Eutectic Assembly	Pb-Free Assembly
Average ramp-up rate (T_L to T_P)	<3°C/sec	<3°C/sec
Preheat		
- Temperature Min (T_{Smin})	100°C	150°C
- Temperature Max (T_{Smax})	150°C	200°C
- Time (min to max) (t_s)	60~120 sec	60~180 sec
T_{Smax} to T_L		
- Ramp-up Rate	<3°C/sec	<3°C/sec
Time maintained above:		
- Temperature (T_L)	183°C	217°C
- Time (t_L)	60~150 sec	60~150 sec
Peak Temperature (T_P)	240°C +0/-5°C	260°C +0/-5°C
Time within 5°C of actual Peak Temperature (t_p)	10~30 sec	20~40 sec
Ramp-down Rate	<6°C/sec	<6°C/sec
Time 25°C to Peak Temperature	<6 minutes	<8 minutes

3. Flow (wave) soldering (solder dipping)

Products	Peak temperature	Dipping time
Pb devices.	245°C ±5°C	5sec ±1sec
Pb-Free devices.	260°C +0/-5°C	5sec ±1sec