



HM94

PNP EPITAXIAL PLANAR TRANSISTOR

Description

The HM94 is designed for application requires high voltage.

Features

- High voltage: $V_{CEO}=400V(\text{min})$ at $I_C=1mA$
- High current gain: $I_C=300mA$ at $25^\circ C$
- Complementary with HM44

Absolute Maximum Ratings

- Maximum Temperatures
Storage Temperature -55 ~ +150 °C
Junction Temperature +150 °C Maximum
- Maximum Power Dissipation
Total Power Dissipation ($T_A=25^\circ C$) 1 W
- Maximum Voltages and Currents ($T_A=25^\circ C$)
 V_{CBO} Collector to Base Voltage -400 V
 V_{CEO} Collector to Emitter Voltage -400 V
 V_{EBO} Emitter to Base Voltage -6 V
 I_C Collector Current -500 mA

Electrical Characteristics ($T_A=25^\circ C$)

Symbol	Min.	Typ.	Max.	Unit	Test Conditions
BV_{CBO}	-400	-	-	V	$I_C=-100\mu A$
BV_{CEO}	-400	-	-	V	$I_C=-1mA$
BV_{EBO}	6	-	-	V	$I_E=-10\mu A$
I_{CBO}	-	-	-100	nA	$V_{CB}=-400V$
I_{EBO}	-	-	-100	nA	$V_{EB}=-6V$
I_{CES}	-	-	-500	nA	$V_{CE}=-400V, V_{BE}=0$
* $V_{CE(sat)1}$	-	-	-350	mV	$I_C=-1mA, I_B=-0.1mA$
* $V_{CE(sat)2}$	-	-	-500	mV	$I_C=-10mA, I_B=-1mA$
* $V_{CE(sat)3}$	-	-	-750	mV	$I_C=-50mA, I_B=-5mA$
* $V_{BE(sat)}$	-	-	-750	mV	$I_C=-10mA, I_B=-1mA$
* h_{FE1}	40	-	-		$V_{CE}=-10V, I_C=-1mA$
* h_{FE2}	50	-	300		$V_{CE}=-10V, I_C=-10mA$
* h_{FE3}	45	-	-		$V_{CE}=-10V, I_C=-50mA$
* h_{FE4}	40	-	-		$V_{CE}=-10V, I_C=-100mA$

*Pulse Test: Pulse Width $\leq 380\mu s$, Duty Cycle $\leq 2\%$

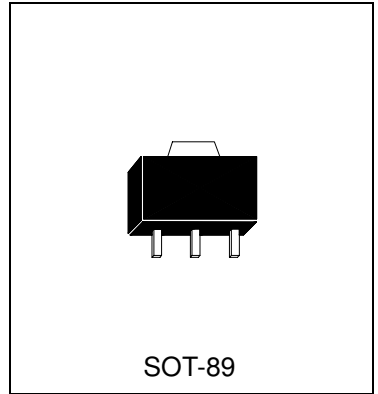



Characteristics Curve

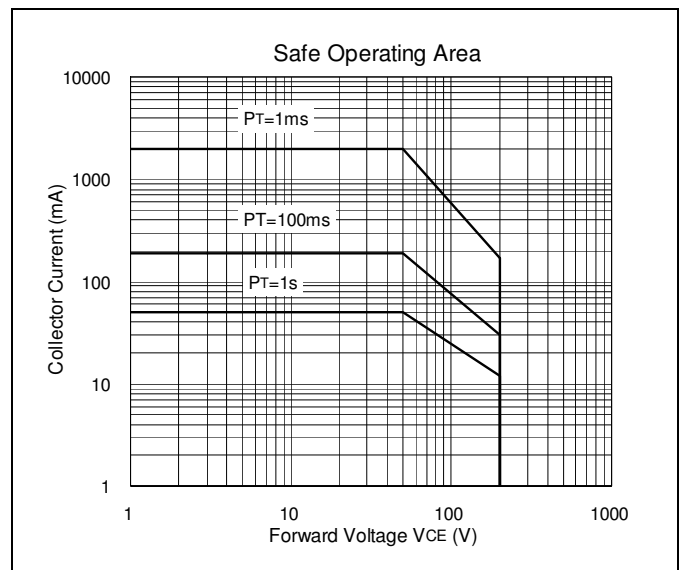
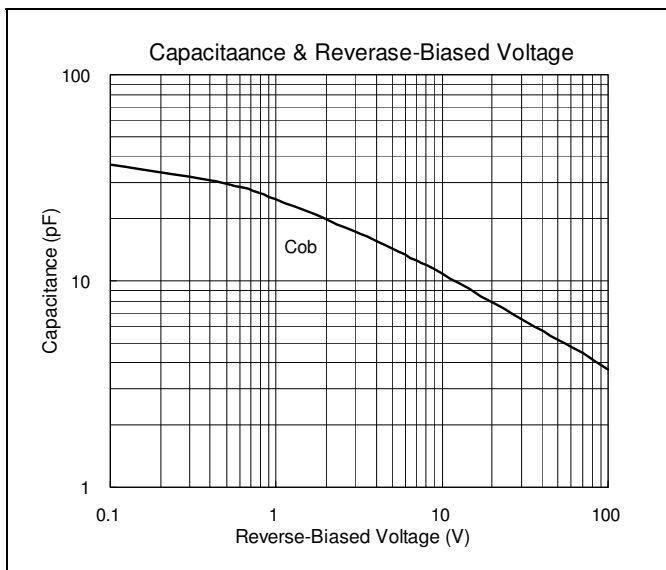
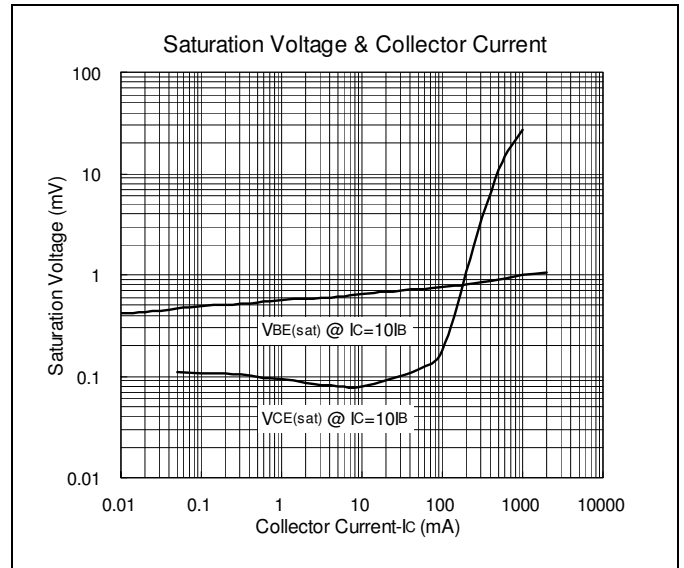
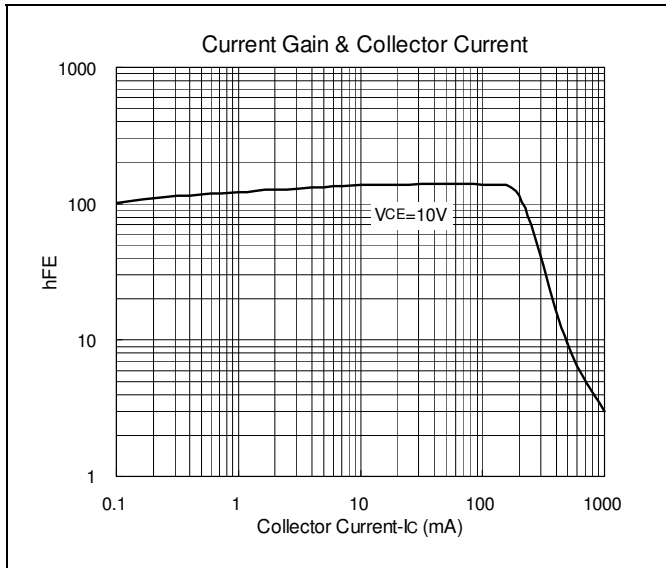



SOT-89 Dimension

3-Lead SOT-89 Plastic
Surface Mounted Package
HSMC Package Code: M

Marking:

Date Code Control Code

Pb Free Mark
Pb-Free: "●" (Note)
Normal: None

Note: Green label is used for pb-free packing

Pin Style: 1.Base 2.Collector 3.Emitter

Material:

- Lead solder plating: Sn60/Pb40 (Normal), Sn/3.0Ag/0.5Cu or Pure-Tin (Pb-free)
- Mold Compound: Epoxy resin family, flammability solid burning class: UL94V-0

DIM	Min.	Max.
A	4.40	4.60
B	4.05	4.25
C	1.50	1.70
D	2.40	2.60
E	0.36	0.51
F	*1.50	-
G	*3.00	-
H	1.40	1.60
I	0.35	0.41

*: Typical, Unit: mm

Important Notice:

- All rights are reserved. Reproduction in whole or in part is prohibited without the prior written approval of HSMC.
- HSMC reserves the right to make changes to its products without notice.
- **HSMC semiconductor products are not warranted to be suitable for use in Life-Support Applications, or systems.**
- HSMC assumes no liability for any consequence of customer product design, infringement of patents, or application assistance.

Head Office And Factory:

- **Head Office** (Hi-Sincerity Microelectronics Corp.): 10F., No. 61, Sec. 2, Chung-Shan N. Rd. Taipei Taiwan R.O.C.
Tel: 886-2-25212056 Fax: 886-2-25632712, 25368454
- **Factory 1:** No. 38, Kuang Fu S. Rd., Fu-Kou Hsin-Chu Industrial Park Hsin-Chu Taiwan. R.O.C
Tel: 886-3-5983621~5 Fax: 886-3-5982931



Soldering Methods for HSMC's Products

1. Storage environment: Temperature=10°C~35°C Humidity=65%±15%
2. Reflow soldering of surface-mount devices

Figure 1: Temperature profile

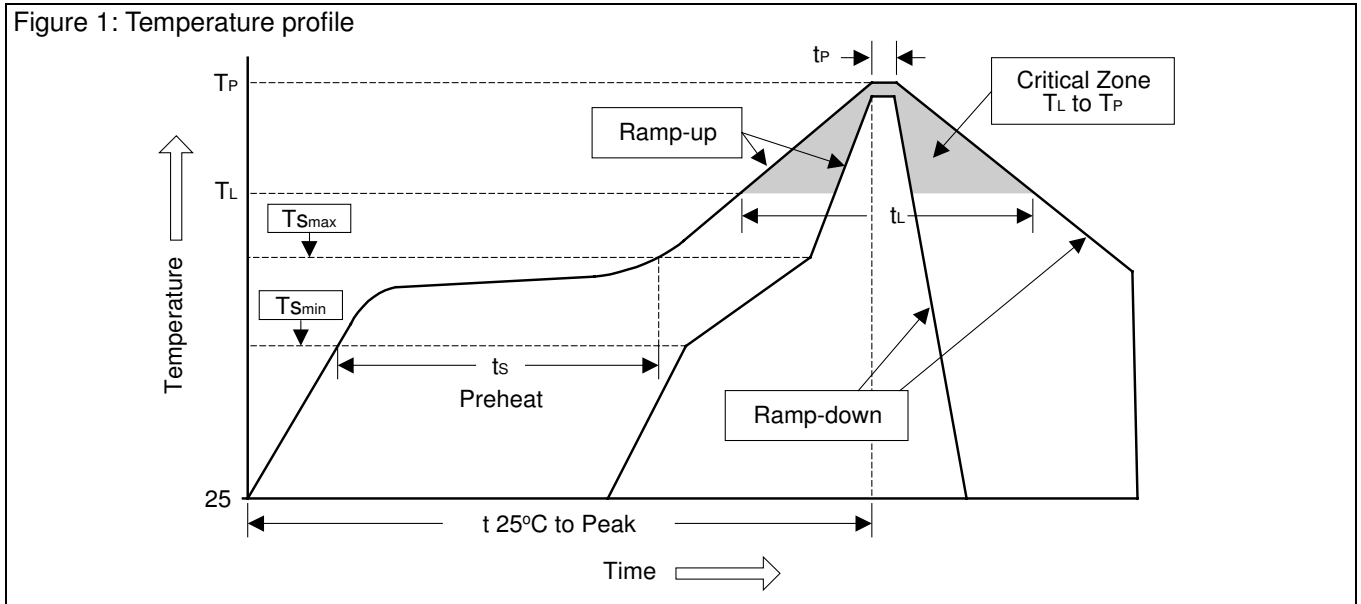

Profile Feature	Sn-Pb Eutectic Assembly	Pb-Free Assembly
Average ramp-up rate (T_L to T_P)	<3°C/sec	<3°C/sec
Preheat		
- Temperature Min (T_{smin})	100°C	150°C
- Temperature Max (T_{smax})	150°C	200°C
- Time (min to max) (t_s)	60~120 sec	60~180 sec
T_{smax} to T_L		
- Ramp-up Rate	<3°C/sec	<3°C/sec
Time maintained above:		
- Temperature (T_L)	183°C	217°C
- Time (t_L)	60~150 sec	60~150 sec
Peak Temperature (T_P)	240°C +0/-5°C	260°C +0/-5°C
Time within 5°C of actual Peak Temperature (t_p)	10~30 sec	20~40 sec
Ramp-down Rate	<6°C/sec	<6°C/sec
Time 25°C to Peak Temperature	<6 minutes	<8 minutes

3. Flow (wave) soldering (solder dipping)

Products	Peak temperature	Dipping time
Pb devices.	245°C ±5°C	5sec ±1sec
Pb-Free devices.	260°C +0/-5°C	5sec ±1sec