

## Silicon Oscillators "SH32" and "SH53" Series



**MERCURY**  
Since 1973

The "SH" series is an extremely low power precision silicon oscillator with a total frequency error of less than 1.0%. This Si-gate CMOS oscillator produces a square wave output and requires no external components other than power supply bypass capacitors. The operating voltage range is from +1.5V to +3.3V, which allows operation from a single Li-Ion cell or 2 AA alkaline cells.

SH53



SH32



RoHS Compliant Product  
by Mercury

### Features:

- Hermetically sealed & metal-lid grounded ceramic leadless package
- Superior moisture resistant, compared to plastic molded packaging
- Internally frequency tuned to the specified voltage (no external components needed)
- Ultra-low supply current [10 uA typical at +2.5V]
- Fast start up time
- +1.55V to +3.3V single supply voltage
- Withstands high vibration and harsh environments
- Suitable for light weight, compact consumer electronic devices
- Ideal for high density boards
- RoHS compliant and (Pb) lead-free product
- United States Patent No: 6,281,732 \*

### Applications:

- ▲ Microprocessor Clocks
- ▲ Low Speed USB's
- ▲ Remote Controls
- ▲ Display Drives
- ▲ Home Appliances
- ▲ Motor Controls
- ▲ Building Controls
- ▲ Advanced Battery Chargers
- ▲ Replaces Ceramic Resonators

### Part Number Format and Example:

Example: 18SH32-327 ↖: User input

<small>↖</small>		<small>↖</small>		<small>↖</small>
18	SH	32	-	327
Supply voltage code "33" for 3.3V <sub>DD</sub> "3" for 3.0 V <sub>DD</sub> "25" for 2.5V <sub>DD</sub> "18" for 1.8V <sub>DD</sub> "15" for 1.55V <sub>DD</sub>	Product series	Package size. "32" for 3.2x2.5x1.0 mm "53" for 5x3.2x1.2 mm		Frequency in KHz. 327 = 32.768 KHz

\*A Collaboration with **Micro Oscillator Inc.**

**General Specifications:** Ta=+25°C



**MERCURY** [www.mercury-crystal.com](http://www.mercury-crystal.com)

TEL (886)-2-2406-2779, FAX (886)-2-2496-0769, e-mail: [sales-tw@mercury-crystal.com](mailto:sales-tw@mercury-crystal.com)  
U.S.A. TEL (1)-909-466-0427, FAX (1)-909-466-0762, e-mail: [sales-us@mercury-crystal.com](mailto:sales-us@mercury-crystal.com)

**Silicon Oscillators**  
**“SH32” and “SH53” Series**



**MERCURY**  
 Since 1973

Product Series	“SH32” series. Package size: 3.2x2.5x1.0 mm CLCC 4 pads				
	“SH53” series. Package size: 5.0x3.2x1.2 mm CLCC 4 pads				
Frequency Range	20 KHz to 80 KHz				
Popular Frequency	32.768 KHz				
Input Voltage (V <sub>DD</sub> ) D.C.	+1.55 V±5%	+1.8 V±5%	+2.5 V±5%	+3.0 V±5%	+3.3 V±5%
Voltage Code for Part No.	15	18	25	3	33
SH32 Availability	SH32			Not available	Not available
SH53 Availability	SH53				
Current Consumption	3µA typical	5µA typical	10µA typical	16µA typical	18 µA typical
Initial Frequency Accuracy	± 0.5% max. at +25°C				
Frequency Error vs Supply Voltage	±0.2% typical	±0.2% typical	±0.3% typical	±0.2% typical	±0.2% typical
Frequency Error vs Temperature (0°C to +70°C)	±0.1% typical	±0.1% typical	±0.3% typical	±0.2% typical	±0.2% typical
Frequency Standard Deviation	0.5 Hz. typ.	0.5 Hz. typ.	1 Hz. typ.	2 Hz. typ.	2 Hz. typ.
Output Logic and Waveform	CMOS. Square wave.				
Output “High” Voltage; V <sub>OH</sub>	0.9*V <sub>DD</sub> min.				
Output “Low” Voltage; V <sub>OL</sub>	0.1*V <sub>DD</sub> max.				
Duty Cycle	50% ±5% at 50% V <sub>DD</sub>				
Rise Time (Tr)/ Fall Time (Tf) Condition: 12 pF Load	38n sec. typ.	33n sec. typ.	25n sec. typ.	24n sec. typ.	24n sec. typ.
Start-up Time (Ts). (note 1)	30 u sec. max.				
Oscillator Turn On Time. (note 2)	0.3 sec. min				
Supply Voltage Rise Time	1 u sec. min.				

Notes:

1/ Output signal frequency is stable by the second pulse cycle, after the supply voltage is stable. This time is dependent on the oscillator frequency, and it is given for 32.768 KHz.

2/ Oscillator start up requires a relatively clean supply voltage that does not drop down towards zero volts during turn on. After the supply voltage drops below about 1v, the voltage should go to 0v for 0.3 sec. min before the oscillator is turned on again.

**Absolute Maximum Ratings**

Power Supply Voltage V <sub>DD</sub>	+3.6 V max.
Input Voltage	-0V min.; V <sub>DD</sub> V max.
Output Voltage	-0V min.; V <sub>DD</sub> V max.
Operation Junction Temperature	-55°C min.; +125°C max.



**Environmental Performance Specifications**

<b>Green Requirement</b>	RoHS compliant, Pb (lead) free in accordance with EU Directive 2002/95/EC 6/6 (2002/95/EC) and WEEE (2002/96/EC). Free of halide, cadmium, hexavalent chromium, lead, mercury, PBB's and PBDE's.
<b>Moisture Sensitivity Level</b>	Level 1 (infinite) according to IPC/JEDEC J-STD-020D.1
<b>Second Level Interconnect</b>	e4
<b>Operating Temp. Range</b>	0 to +70°C
<b>Storage Temp. Range</b>	-55 to +125°C
<b>Humidity</b>	85% RH, 85°C, 48 hours
<b>Fine Leak / Gross Leak</b>	MIL-Std-883, method 1014, condition A / MIL-Std-883, method 1014, condition C
<b>Solderability</b>	MIL-STD-202F method 208E
<b>Reflow</b>	260°C max. for 10 sec.max. 2 reflows.
<b>Vibration</b>	MIL-STD-202F method 204, 35G, 50 to 2000 Hz
<b>Shock</b>	MIL-STD-202F method 213B, test condi. E, 1000GG ½ sine wave
<b>Resistance to Solvent</b>	MIL-STD-202, method 215
<b>Temperature Cycling</b>	MIL-STD-883, method 1010
<b>Pad Surface Finish</b>	Gold (0.3 to 1.0 µm) over nickel (1.27 to 8.89 µm)
<b>Weight of the Device</b>	SH32: 0.042grams typical; SH53: 0.078grams typical

**Typical Output Waveform**

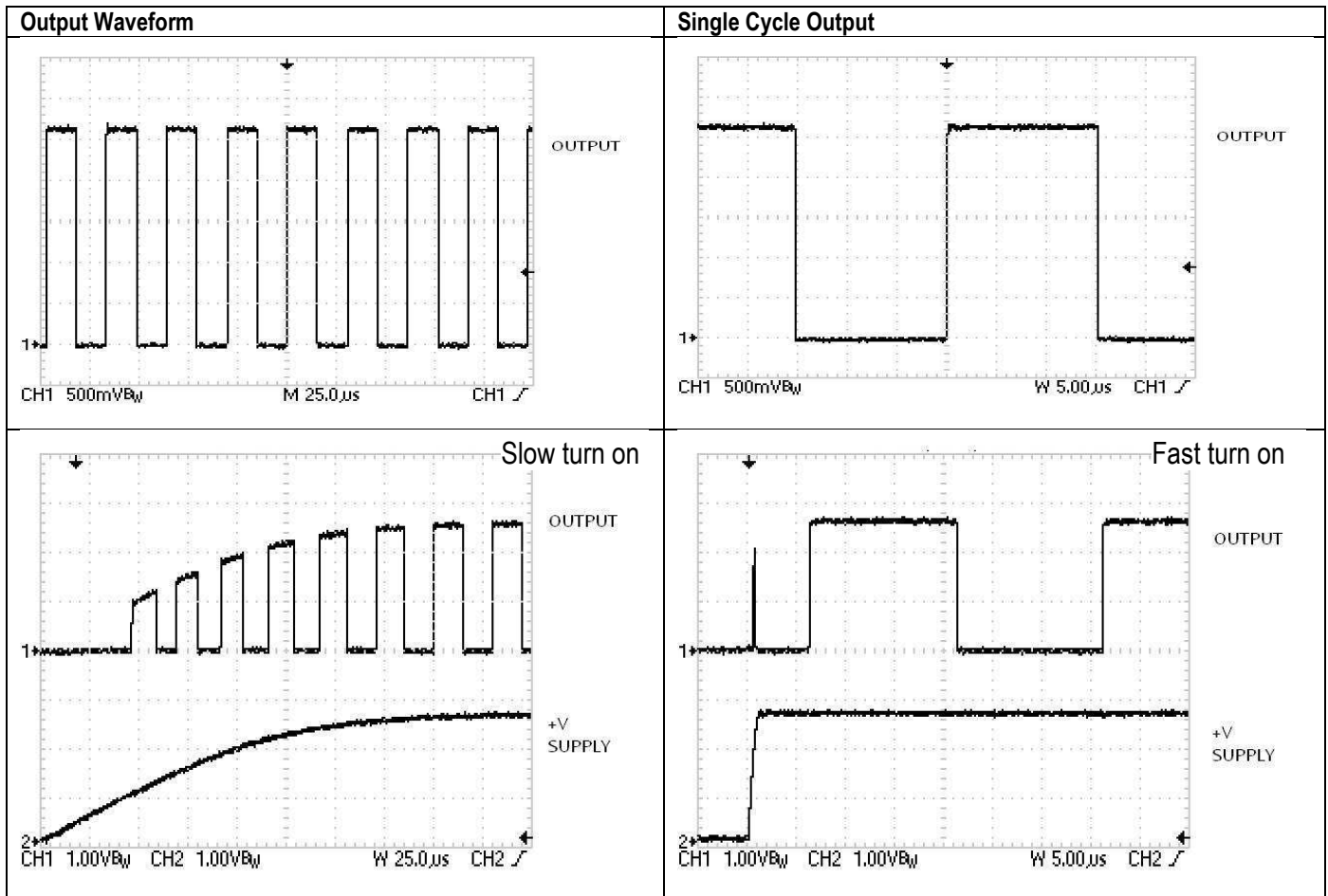



**SH32 Package Dimensions and Recommended Solder Pad Layout** unit: (mm)

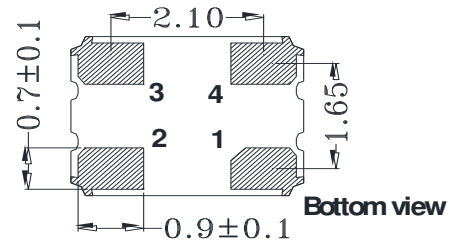
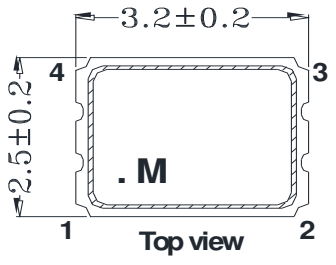

Pad No.	Function
1	No connection
2	Ground
3	Output
4	Supply voltage

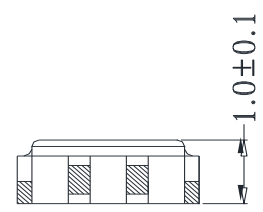
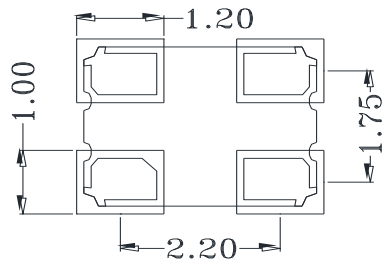

**SH53 Package Dimensions and Recommended Solder Pad Layout** unit: (mm)

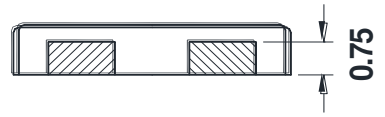
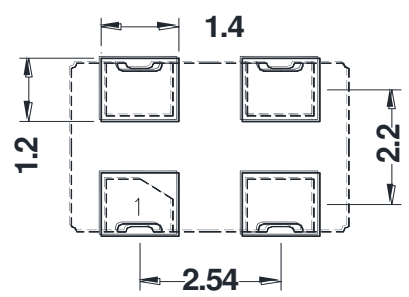
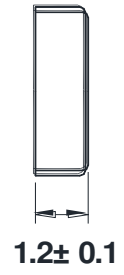
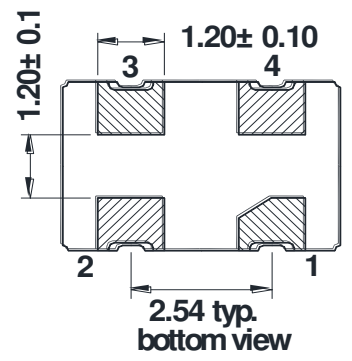
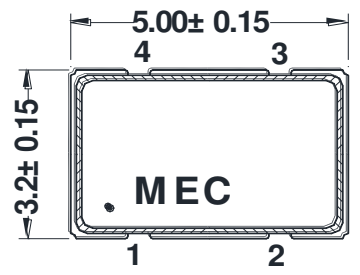

Pad No.	Function
1	No connection
2	Ground
3	Output
4	Supply voltage

**SH32 Product Marking** “S”: Silicon Oscillator. “•”: Pad 1 (top view); “M”: Mercury

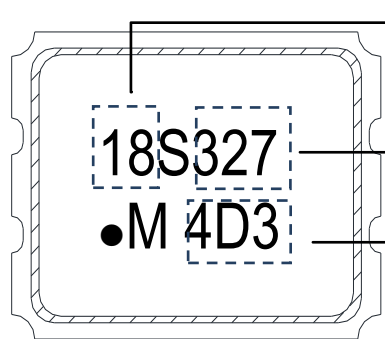

→ Voltage code  
 → Output frequency in KHz: “327”= 32.768 KHz  
 → Date code:  
 1<sup>st</sup> digit: Year. 2014=4  
 2<sup>nd</sup> letter: Month. A (Jan.)~ K (Dec.)  
 3<sup>rd</sup> digit: Week number of the month

**Silicon Oscillators**  
**“SH32” and “SH53” Series**



**MERCURY**  
 Since 1973

**SH53 Product Marking** “SH”: Silicon Oscillator; “●”: Pad 1 index (top view); “MEC”: Mercury

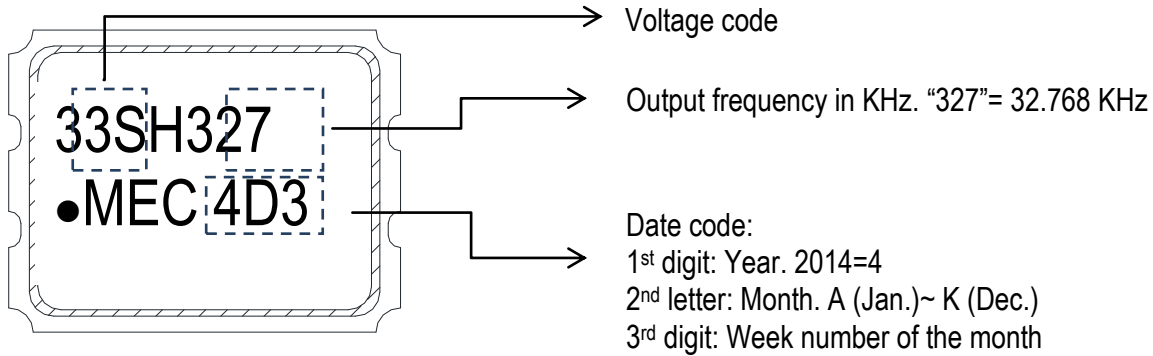

**Recommended Solder Reflow Profile**(perIPC/JEDEC J-STD-020D.1)

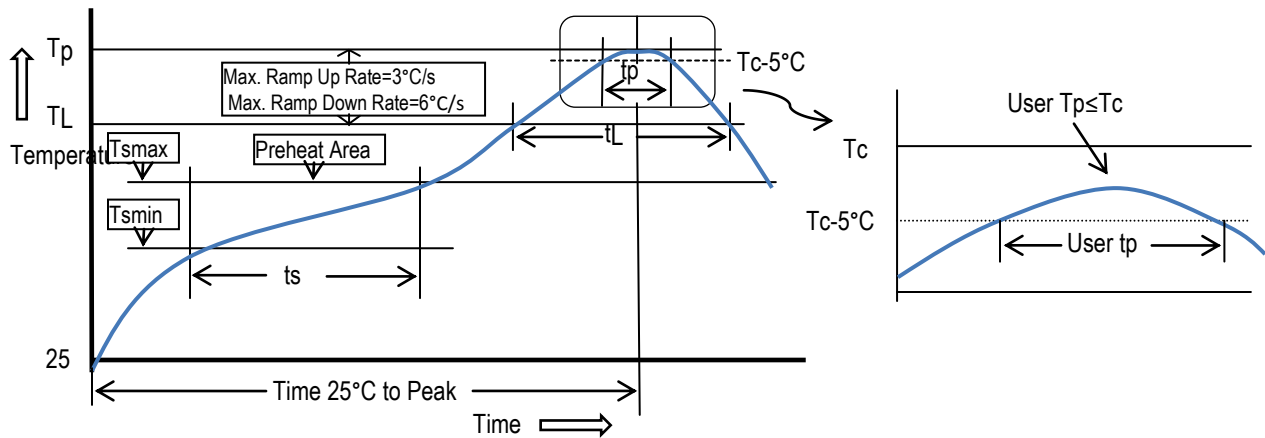

Profile Feature	Sn-Pb Eutectic Assembly	Pb-free Assembly
Preheat/Soak		
- Temperature min. (T <sub>s</sub> min.)	100°C	150°C
- Temperature max. (T <sub>s</sub> max.)	150°C	200°C
- Time (t <sub>s</sub> ) (T <sub>s</sub> min. to T <sub>s</sub> max.)	60 to 120 seconds	60 to 180 seconds
Ramp-up rate (T <sub>L</sub> to T <sub>p</sub> )	3°C / sec. max.	3°C / sec. max.
Liquidus temperature (T <sub>L</sub> )	183°C	217°C
Time (t <sub>L</sub> ) maintained above T <sub>L</sub>	60 to 150 seconds	60 to 150 seconds
Peak package body temperature (T <sub>p</sub> )	235°C	260°C
Time (T <sub>p</sub> ) within 5°C of the classification temperature T <sub>c</sub>	10 to 30 seconds	20 to 40 seconds
Ramp-down rate (T <sub>p</sub> to T <sub>L</sub> )	6°C / second max.	6°C / second max.
Time 25°C to peak temperature	6 minutes max.	8 minutes max.

All temperatures refer to the topside of the package, measured on the package body surface.