

SY01-SMC

Date: April 20, 2002

- **INTRODUCTION**

The SY01-SMC is an accurate time and frequency source that has been designed as a module level subsystem for easy incorporation into SONET/SDH systems or network elements. The SY01-SMC is an advanced synchronization solution for timing, jitter and wander issues in accordance with specification for SONET Minimum Clock (SMC) given by BellCore GR-253-CORE and BellCore GR-1244-CORE.

- **FEATURES**

A synchronization solution for timing, jitter and wander concerns in a single module.

Complies with Bellcore GR-1244-CORE and GR-253-CORE for SMC applications.

Supports four modes of operation: Locked to Reference 1, Locked to Reference 2, Holdover and Free-run.

Accepts reference inputs from two independent sources from **8 kHz to 77.76 MHz**.

Provides two outputs **8KHz to 77.76 MHz**.

Loop filtering utilizing application specific software in the digital signal processor (DSP).

Continuously monitors and evaluate input reference signals.

Creates a history buffer for Holdover mode operation.

Manual or Automatic selection between timing modes.

Alarm and status signal.

Host interface and JTAG port.

Small dimensions of 2.0 x 2.0 x 0.55 inch.

- **APPLICATIONS**

The SY01-SMC performs clock regeneration as a Synchronous Equipment Clock (SEC), and is particularly designed for SONET equipment and network elements. However, SY01-SMC can be used in any other telecommunication equipment where synchronization is necessary if the performance allowed.

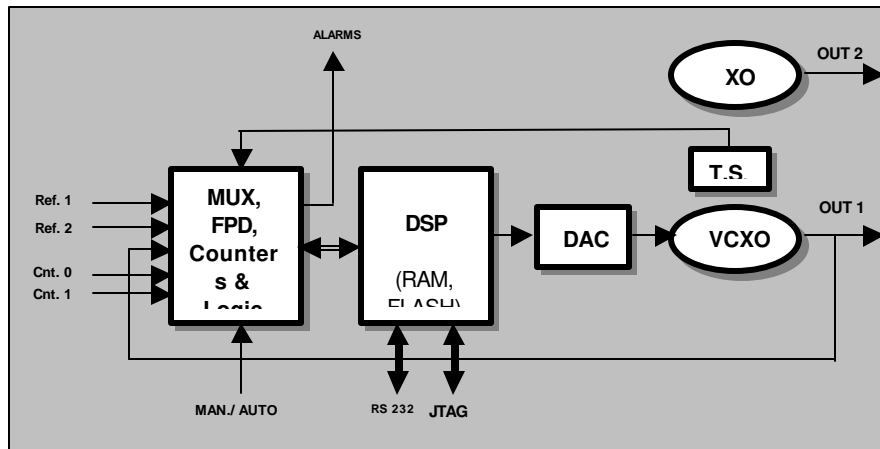

Figure 1. - The functional block diagram of SY01-SMC

• DESCRIPTION

The SY01-SMC synchronization module is a Digital PLL (DPLL), which utilizes application specific software in the digital signal processor (DSP). The DSP is complemented by fast hardware logic (CPLD) where all multiplexers, counters, dividers, phase detectors, output frequency converters and other control logic circuits are completely implemented. The functional block diagram with maximum configuration is shown in figure 1. Depending on the application, the user can specify an appropriate configuration to fit their system requirements. The basic configuration utilizes one DPLL with a VCXO as on-board oscillator, shown in figure 1. The VCXO is driven by a digital-to-analog converter (DAC1) and provides the accurate and stable signal with less power consumption. The output frequency converters scale the output frequency from the oscillator. For other configurations, please contact RAMI. The second output is provided by free running crystal oscillator.

✓ The module operates in the following four timing modes:

Free-run

In this mode the unit is unlocked to either of the inputs. The accuracy of the output frequencies in this mode is ± 20 ppm. Free-run mode is typically used when a master clock source is required, not valid history of data for the Holdover mode, or immediately following system power-up before network synchronization is achieved. In the Free-run Mode, the SY01-SMC provides timing and synchronization signals that are based on the accuracy of on-board oscillators only, and are not synchronized to the reference signals.

Holdover

In this mode the module has lost its reference inputs and is utilizing stored timing data, called history, to control the output frequency. Holdover Mode is typically used while network synchronization is temporarily disrupted. In Holdover Mode, the SY01-SMC provides timing, based on data from the history buffer, while unlocked to an external reference signal. The history data is determined while the device is locked to an external reference signal. The stability of the output signal in holdover mode depends primarily on the stability of on-board oscillator and environment effects where the clock is mounted. The SY01-SMC uses a VCXO as an on-board oscillator but other types of oscillators are available.

Locked to Ref.1

In this mode the output of the module is phase locked to input reference 1.

Locked to Ref.2

In this mode the output of the module is phase locked to input reference 2.

The REF1 or REF2 Modes are typically used when a slave clock source is synchronized to the network. In these modes, the SY01-SMC provides timing signals, which are synchronized, to one of two references inputs (REF1 or REF2). The input reference signals may have a variety of nominal frequencies, which is typically specified by the end user. When the modes are selected the unit goes through a reference evaluation, and then a frequency acquisition, and finally to phase locking.

- **Input References**

The SY01-SMC module accepts two input references EX REF1 and EX REF2. End users can specify the frequencies within a range of 8 kHz to 77.76 MHz. The input reference signals are HCMOS/TTL levels with timing characteristic in according to Bellcore GR-1244-core 3.2.1.R3-1 or equivalent standards. Please note that the end user must specify the two input frequencies at the time of order.

- **Output Signals**

The SY01-SMC module provides two output signals OUT and OPT OUT. The first outputs are generated by the internal oscillator and scaled by the output frequency converters if necessary. The second output is coming from free running crystal oscillator. The performance of the module significantly depends on the internal oscillator and special care was taken to define its specification. A high quality Crystal Oscillator (VCXO) is used as the internal oscillator. The frequency of the oscillator is specified according to the network application where the SY01-SMC will be used. The frequency converters divide signal from the oscillator to the specified frequencies.

- **The SY01 Operation mode**

By changing the control inputs the user can change the state of the SY01 according to the state diagram. The SY01 offers two ways to manage state machine:

| J1 jumper | State diagram control |
|------------------|------------------------------|
| Open | Manual |
| Closed | Automatic |

The behavior of the Manual and Automatic controls are shown on the figures 2 and 3 with an explanation for each transition. In the Automatic control the SY01 can be automatically switched to the reference (if available) regardless of status of the control inputs. In Manual control the unit waits for control inputs to be changed. In both modes the unit will go to the REFERENCE EVALUATION if the previously lost reference is required.

• Control

Two controls are available for the user to control the operation of the SY01-S4. The two external inputs CNT1 and CNT2 provide this feature. Below, the truth table shows behavior of the SY01-S4 module according to the control inputs states.

| CNT2 | CNT1 | MODE OF OPERATION |
|------|------|-------------------|
| 0 | 0 | Free-run |
| 0 | 1 | Locked to REF1 |
| 1 | 0 | Locked to REF2 |

• PIN DESCRIPTION

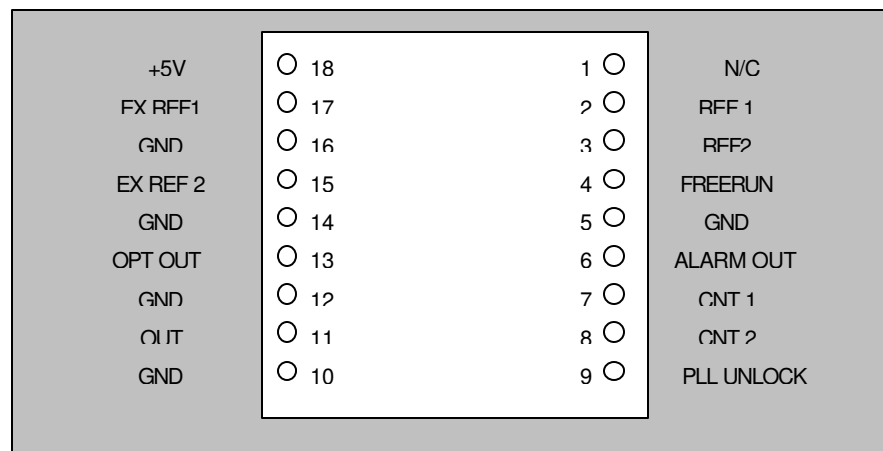

Bottom View

| Pin # | Name | Description |
|---------------|------------|---|
| 1 | HOLD-OVER | Holdover Signal -> the output is high when the unit is in holdover mode |
| 2 | REF 1 | Reference 1 Signal -> the unit is enslaved to the reference 1 |
| 3 | REF 2 | Reference 2 Signal -> the unit is enslaved to the reference 2 |
| 4 | FREERUN | Freerun Signal -> the unit is in the free run mode |
| 6 | ALARM OUT | Alarm signal |
| 7 | CNT 1 | Control Input 1 -> the external input for selecting mode of the unit |
| 8 | CNT 2 | Control Input 2 -> the external input for selecting mode of the unit |
| 9 | PLL UNLOCK | PLL Unlocked Signal -> the unit is unlocked |
| 5,10,12,14,16 | GND | Ground |
| 18 | +5V | Positive Voltage Supply |
| 11 | OUT | Synchronized Output -> the primary output |
| 13 | OPT OUT | Optional Second Output -> the secondary output, optional, user selectable |
| 17 | EX REF1 | External Reference 1 Input -> the input from reference 1 |
| 15 | EX REF 2 | External Reference 2 Input -> the input from reference 2 |

• SPECIFICATION

| | | | |
|------------------------------|--------------------------------|---|--|
| General Specifications | Mechanical | 2" (D) x 2" (W) x 0.55" (H) | Metal box, 18p dual-in-line |
| | Power Environment | 5VDC, 2W Operating Temperature Storage Temperature Humidity EMC | -20°C to 70°C -40° to 85°C 5% to 95% non-condensing FCC Part 15, Class B, CE Marked, UL |
| | Internal Oscillators | Voltage Controlled Crystal Oscillator (VCXO) and Clock Oscillator | |
| Input Signals | Number of Inputs | 2 | |
| | Input reference frequency | Selectable from range 8kHz to 77.76MHz | |
| | Signal Level | HCMOS/TTL Compatible | |
| | Time Reference characteristics | Bellcore: GR-1244-core | |
| Output Signals | Number of Outputs | 2 | |
| | Output 1 | Selectable from range 8kHz to 77.76MHz | |
| | Output 1 Signal Level | HCMOS | |
| | Output 2 | Selectable from range 8kHz to 77.76MHz | Free-running clock |
| | Output 2 Signal Level | HCMOS | |
| Signal Quality Performance | Jitter generation | <0.03Uip-p | |
| | Jitter tolerance | Bellcore: GR-253-core rev. 1 | |
| | Wander generation | Bellcore: GR-253-core rev. 1 | |
| | Wander tolerance | Bellcore: GR-253-core rev. 1 | |
| | Wander transfer | Bellcore: GR-1244-core | |
| | Filtering (Wander transfer) | <0.1Hz | |
| Frequency Output Performance | Free run accuracy | ±20ppm | |
| | Holdover stability | ±4.6ppm | |
| | Initial offset | <±0.05ppm | |
| | Temperature | <±4.1ppm | |
| | Pull-in/Hold-in range | ±20ppm | |
| | Holdover history | 1 min | |

- OUTLINE DRAWING

