

## VE/VC8825A-LZ-100-FREQ-CF-EL VE/VC8925A-LZ-100-FREQ-CF-EL (3.3V)

- Specifically designed for OC192; FEC applications
- Meets SONET Jitter requirement
- Available at 3.3V\*\*\*\*\* (Shall use 9 in the 2<sup>nd</sup> figure P/N location... Example; VC8925A...)
- Enable/Disable – optional Feature

### MECHANICAL SPECIFICATION

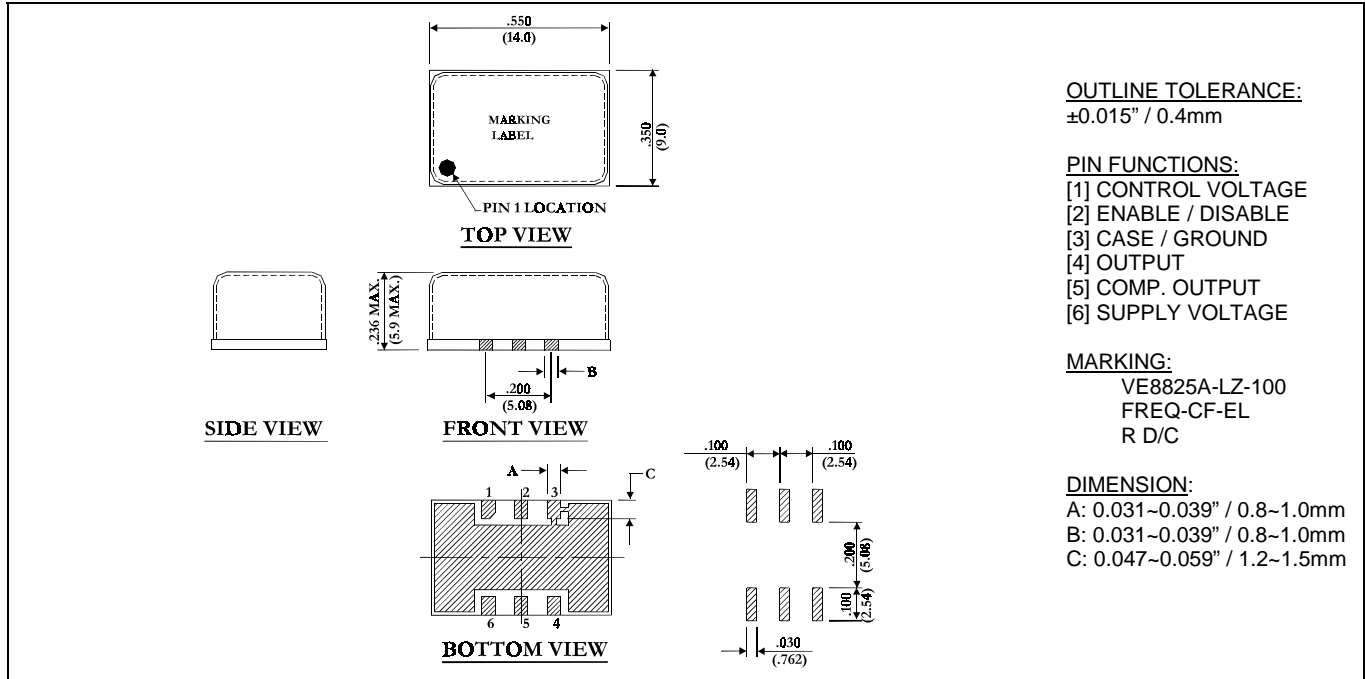

### ELECTRICAL SPECIFICATION

PARAMETER	SYMBOL	CONDITIONS	VALUE	UNIT
Frequency, nom	fo	-	622.08; 666.5143; 669.3266	MHz
Supply voltage, nom.	Vcc	Vcc±5%	+5.0; +3.3	V
Supply current, max.	Is	Vcc=nom, Vc=0.5*Vcc, Ta=+25°C, 50Ω to Vcc-2.0VDC load	135.0	mA
PECL output level	VOH / VOL	Vcc=nom, load=50Ω to Vcc-2.0VDC	Vcc-1.025/Vcc-1.62	V
Duty cycle	DC	load=50Ω to Vcc-2.0VDC / @ 50%Vcc, Ta=+25°C	40...60	%
Rise- / fall time, max.	tr / tf	20%~80% Vout, 80%~20% Vout, max	0.550	ns
Jitter, rms, max.	J	1σ, Fj= 12kHz...20MHz	1.0	ps
Freq. stability vs. temperature, max.	Δf/fc(Ta)	Ta=0°C...+70°C, (ref. to +25°C)	±25.0	ppm
Freq. stability vs. supply, max.	Δf/fc(ΔVcc)	± 5% Supply change	±5.0	ppm
Freq. stability vs. load, max.	Δf/fc(Δload)	± 10%Load change	±3.0	ppm
Aging characteristics, max.	Δf/fc(Δt)	Δt=1 <sup>st</sup> year Δt=per year thereafter	±4.0 ±2.0	ppm ppm
Control voltage range	Vc	DC	+0.5...+4.5 (0...3.3 @Vcc=3.3V)	V
Freq. pulling range, min.	Δf/fc	over the control voltage range	±100.0	ppm
Settability	Vfo	Ta=+25°C ±1°C	+2.5 ± 0.5 (+1.65±0.25 @ Vcc=3.3V)	V
Linearity, max.	Δf/V	Positive slope	± 10.0	%
Input impedance, min.	Zin	-	10.0	KΩ
Modulation freq. bandwidth, min.	MBW(-3dB)	Vcc=nom, Vc=0.5*Vcc, Ta=+25°C, 50Ω to Vcc-2.0VDC load	10.0	KHz
Enable option	En	Pin 2=Low, Vcc-1.620 (max.)	Enabled	-
Disable option	Dis	Pin 2=High, Vcc-1.025 (min.)	Pin 4 will assume a fixed level of logic "0", and pin 5 will assume a fixed level of logic "1"	-
Operating temperature range	Ta	-	0...+70	°C
Storage temperature range	T(stg)	-	-40...+90	°C
Absolute voltage ranges	Vcc, Vc(abs)	Non-destructive, DC	-0.5...+7.0	V

■ **TIMING DIAGRAM**

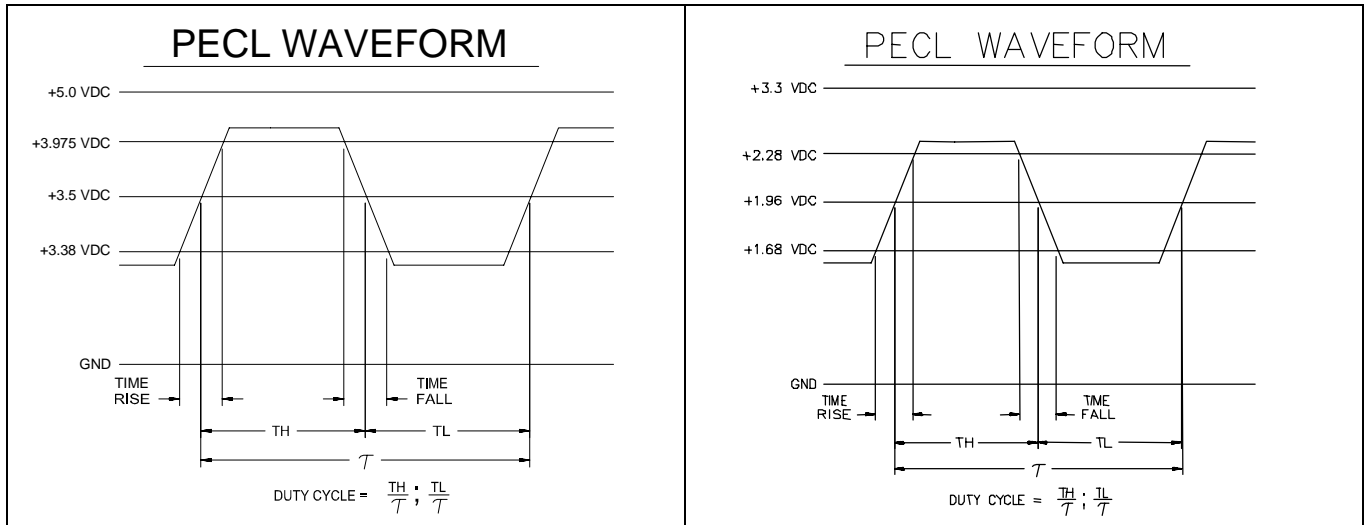

■ **ELECTRICAL TEST DIAGRAM**

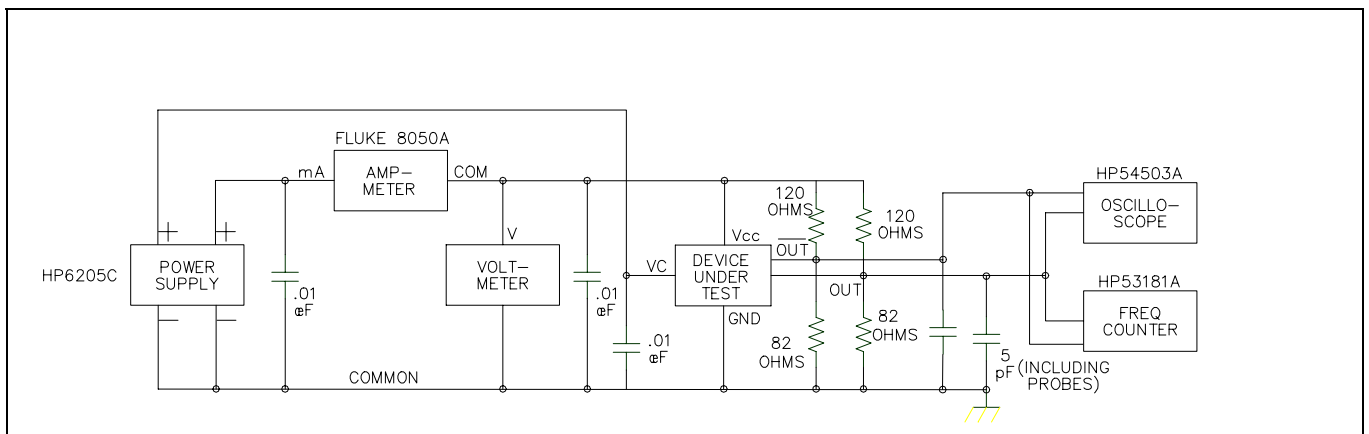

■ **REFLOW SOLDER**

