

KCB812

SPDT Switch with Driver

DC – 6 GHz



Features

- Wideband frequency range: DC to 6 GHz
- Isolation: 48 dB @ 2 GHz
- Single Positive Control
- Non Reflective
- High Reliability Class B and S Screening Available
- See Page 2 for Hi –Rel Ordering Details

Description

The KCB812 is a GaAs FET Non Reflective high performance, High Isolation switch.

The KCB812 uses Hermetic Surface-Mount Technology (SMT) for Defense and Satellite application.

The device can be supplied and tested to the screening requirements of MIL-PRF-38535 Class B and S, in addition to the required QCI.

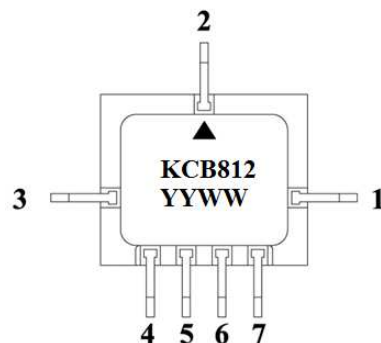

1	RF 1
2	RF C
3	RF 2
4	-5 Vdc
5	Vctrl
6	NC
7	GND

Electrical Characteristics (+25°C)

Parameter	Conditions	Min.	Typ.	Max.	Units
Insertion Loss	DC – 1.0 GHz			1.1	dB
	DC – 2.0 GHz			1.2	dB
	DC – 4.0 GHz			2.0	dB
	DC – 6.0 GHz			2.2	dB
Return Loss (I/O)	DC – 1.0 GHz			1.3:1	dB
	DC – 2.0 GHz			1.5:1	dB
	DC – 4.0 GHz			1.8:1	dB
	DC – 6.0 GHz			2.0:1	dB
Isolation	DC – 1.0 GHz	52			dB
	DC – 2.0 GHz	48			dB
	DC – 4.0 GHz	37			dB
	DC – 6.0 GHz	30			dB
Input Power for 1 dB Output Compression Vctl High = 5V	> 500 MHz		+23		dBm
Third Order Intercept Point (IP3) Vctl = 0V/5V, 0.5 - 2.0 GHz	Two Tone input power = 13 dBm per tone > 500 MHz		+37		dBm
Switching Characteristics Rise, Fall	10/90% or 90/10% RF		20		nS
	50%CTL to 90/10% RF		40		nS

Insertion Loss increases .004dB/°C

KCB812

SPDT Switch with Driver

DC – 6 GHz



Absolute Maximum Ratings

Characteristic	Min Value	Max Value	Units
Supply Voltages (A+B)	0	+0.5	Volts
	4	+5.5	Volts
Negative Supply	-5.25	-4.75	Volts
RF Input Power		+30	dBm
Storage Temperature	-65	+150	° C
Operating Case Temp	-54	+125	° C

Outline Drawing

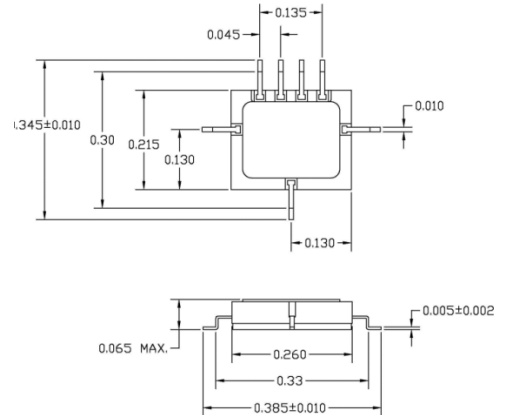

Truth Table / Control Voltages

Vctrl	Signal Path State	
	RFC to RF1	RFC to RF2
1	Loss	Isolation
0	Isolation	Loss

State	Bias Conditions
Low	0.0 to 0.5V @ 100 µA Max
High	4.0V to 5.5V @ 100µA Max

Screening Flow

Test Inspection	MIL – STD -883		Requirement	
	Method	Condition	Class B	Class S
Wafer Lot Acceptance	5007		N/A	Per Wafer Lot
Non-Destructive Bond Pull	2023		Process under Statistical Control	Process under Statistical Control
Internal Visual	2010	A= Class S B = Class B	100%	100%
Temperature Cycle	1010	C	100%	100%
Acceleration	2001	E (Y1 only)	100%	100%
PIND	2020	A (5 Cycles)	N/A	100%
Serialization	Per Product Specification		N/A	100%
Radiographic	2012		N/A	100%
Electrical Test	Per Product Specification	+25°C	100%	100%
Burn In	1015	A	100%	100%
			80 Hours @ 150°C	
Final Electrical	Per Product Specification	+25°C	100%	100%
Group A Electrical	Per Product Specification	-55°C + 125°C	45/0	45/0
Seal				
Fine Leak	1014	A	100%	100%
Gross Leak		C		
External Visual	2009		100%	100%

Ordering Information

KCB Solutions Part Number	Screening Level
KCB812C	Unscreened
KCB812B	Class B Screening
KCB812S	Class S Screening