

KCB827

High Isolation SP4T,
With Driver
0.02 – 4 GHz



Features

- Wideband frequency range: 0.02 to 4 GHz
- Isolation: 50 dB @ 2 GHz / Low Loss: 1.0 dB @ 2 GHz
- Positive Voltage Control: 0.3V to 0.5 V
- Non Reflective
- High Reliability Class H Screening Available
- See Page 3 for Hi-Rel Ordering Details

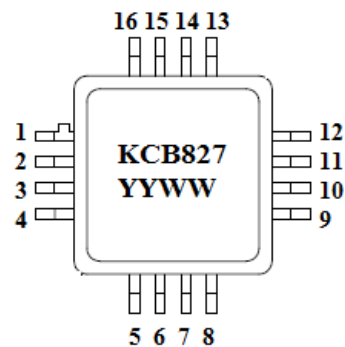

Description

The KCB827 is a GaAs pHEMT Non Reflective high performance, low loss on switch.
The KCB827 uses Hermetic Surface-Mount Technology (SMT) for Defense and Satellite application.
The device can be supplied and tested to the screening requirements of MIL-PRF-38534 Class H, in addition to the required QCI.

Preliminary
4/2013

1	GND	9	RF2
2	RF4	10	GND
3	GND	11	RF1
4	RF3	12	GND
5	GND	13	GND
6	VDD	14	GND
7	VC1	15	RFC
8	VC2	16	GND

Electrical Characteristics (+25°C)

Parameter	Conditions	Min.	Typ.	Max.	Units
Insertion Loss	0.02– 1.0 GHz		0.9	1.10	dB
	1.0 – 2.0 GHz		1.0	1.20	dB
	2.0 – 2.5 GHz		1.1	1.30	dB
	2.5 – 4.0 GHz		1.5	1.90	dB
RF1/RF2 Return Loss (ON-State)	0.02– 1.0 GHz		22		dB
	1.0 – 2.0 GHz		22		dB
	2.0 – 2.5 GHz		18		dB
	2.5 – 4.0 GHz		12		dB
RF1/RF2 Return Loss (OFF-State)	0.02– 1.0 GHz		12		dB
	1.0 – 2.0 GHz		15		dB
	2.0 – 2.5 GHz		15		dB
	2.5 – 4.0 GHz		13		dB
Isolation	0.02– 1.0 GHz	55	60		dB
	1.0 – 2.0 GHz	50	54		dB
	2.0 – 2.5 GHz	48	51		dB
	2.5 – 4.0 GHz	40	46		dB
Input Power for 1 dB Output Compression Vdd= 5V	CW		+30		dBm
Third Order Output Intercept Point (IP3)	Two Tone input power = 7 dBm per tone 1 MHz Spacing		+47		dBm
Switching Characteristics Rise, Fall	10/90% or 90/10% RF		21		nS
	50%CTL to 90/10% RF		125		nS

KCB827

High Isolation SP4T,
With Driver
0.02 – 4 GHz



Absolute Maximum Ratings

Characteristic	Min Value	Max Value	Units
Supply Voltage (Vdd)	3	5	Volts
RF Input Power		+30	dBm
Storage Temperature	-65	+150	° C
Operating Case Temp	-55	+125	° C
Junction Temperature		+150	° C
Operating Frequency	0.03	4.00	GHz

Outline Drawing

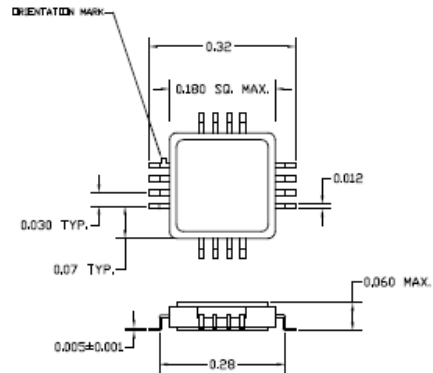

Truth Table / Control Voltages

State	VC1	VC2	RF Path
1	Low	Low	RF1 – RF1
2	Low	High	RF1 – RF2
3	High	Low	RF3 – RF2
4	High	High	RF3 – RF4

State	Bias Conditions
Low	2.5V to Vdd @ 5µA
High	0 to .8V @ 5µA

Preliminary
4/2013

Screening Flow

Test Inspection	MIL – STD -883		Requirement	
	Method	Condition	Class B	Class S
Wafer Lot Acceptance	5007		N/A	Per Wafer Lot
Non-Destructive Bond Pull	2023		Process under Statistical Control	100%
Internal Visual	2010	A= Class S B = Class B	100%	100%
Temperature Cycle	1010	C	100%	100%
Acceleration	2001	E (Y1 only)	100%	100%
PIND	2020	A (5 Cycles)	N/A	100%
Serialization	Per Product Specification		100%	100%
Radiographic	2012		N/A	100%
Electrical Test	Per Product Specification	+25°C	100%	100%
Burn In	1015	A	100% 160 Hours @ 125°C	100% 320 Hours @ 125°C
Final Electrical	Per Product Specification	+25°C	100%	100%
Group A Electrical	Per Product Specification	-55°C + 125°C	45/0	45/0
Seal				
Fine Leak	1014	A	100%	100%
Gross Leak		C		
External Visual	2009		100%	100%

Ordering Information

KCB Solutions Part Number	Screening Level
KCB827C	Unscreened
KCB827B	Class B Screening
KCB827S	Class S Screening