

74AUP1T1326

Low-power dual supply buffer/line driver; 3-state

Rev. 01 — 20 January 2009

Product data sheet

1. General description

The 74AUP1T1326 is a high-performance, low-power, low-voltage, single-bit, dual supply buffer/line driver with output enable circuitry.

The 74AUP1T1326 is designed for logic-level translation applications and combines the functions of the 74AUP1G32 and 74AUP1G126. The buffer/line driver is controlled by two output enable Schmitt trigger inputs (1OE and 2OE) through an OR-gate. The output enable inputs accept standard input signals and are capable of transforming slowly changing input signals into sharply defined, jitter-free output signals. The output of the OR-gate is also available at output 1Y.

The output enable inputs (1OE and 2OE) switch at different points for positive and negative-going signals. The difference between the positive voltage V_{T+} and the negative voltage V_{T-} is defined as the input hysteresis voltage V_H .

Both $V_{CC(A)}$ and $V_{CC(B)}$ can be supplied at any voltage between 1.1 V and 3.6 V making the device suitable for interfacing between any of the low voltage nodes (1.2 V, 1.5 V, 1.8 V, 2.5 V and 3.3 V) with compatible input levels. Pins 1OE, 2OE and 1Y are referenced to $V_{CC(A)}$ and pins A and 2Y are referenced to $V_{CC(B)}$. A logic LOW on both output enable pins causes the output 2Y to assume a high-impedance OFF-state.

The device ensures low static and dynamic power consumption and is fully specified for partial power down applications using I_{OFF} . The I_{OFF} circuitry disables the outputs, preventing any damaging backflow current through the device when it is powered down.

2. Features

- Wide supply voltage range:
 - ◆ $V_{CC(A)}$: 1.1 V to 3.6 V; $V_{CC(B)}$: 1.1 V to 3.6 V.
- High noise immunity
- Complies with JEDEC standards:
 - ◆ JESD8-7 (1.2 V to 1.95 V)
 - ◆ JESD8-5 (1.8 V to 2.7 V)
 - ◆ JESD8-B (2.7 V to 3.6 V)
- ESD protection:
 - ◆ HBM JESD22-A114E Class 2A exceeds 2000 V
 - ◆ MM JESD22-A115-A exceeds 200 V
 - ◆ CDM JESD22-C101C exceeds 1000 V
- Low static power consumption; $I_{CC} = 0.9 \mu\text{A}$ (maximum)
- Latch-up performance exceeds 100 mA per JESD 78 Class II
- Inputs accept voltages up to 3.6 V

- Low noise overshoot and undershoot < 10 % of V_{CC}
- I_{OFF} circuitry provides partial Power-down mode operation
- Multiple package options
- Specified from $-40\text{ }^{\circ}\text{C}$ to $+85\text{ }^{\circ}\text{C}$

3. Ordering information

Table 1. Ordering information

Type number	Package			Version
	Temperature range	Name	Description	
74AUP1T1326GT	$-40\text{ }^{\circ}\text{C}$ to $+85\text{ }^{\circ}\text{C}$	XSON8	plastic extremely thin small outline package; no leads; 8 terminals; body 1 x 1.95 x 0.5 mm	SOT833-1

4. Marking

Table 2. Marking

Type number	Marking code
74AUP1T1326GT	p31

5. Functional diagram

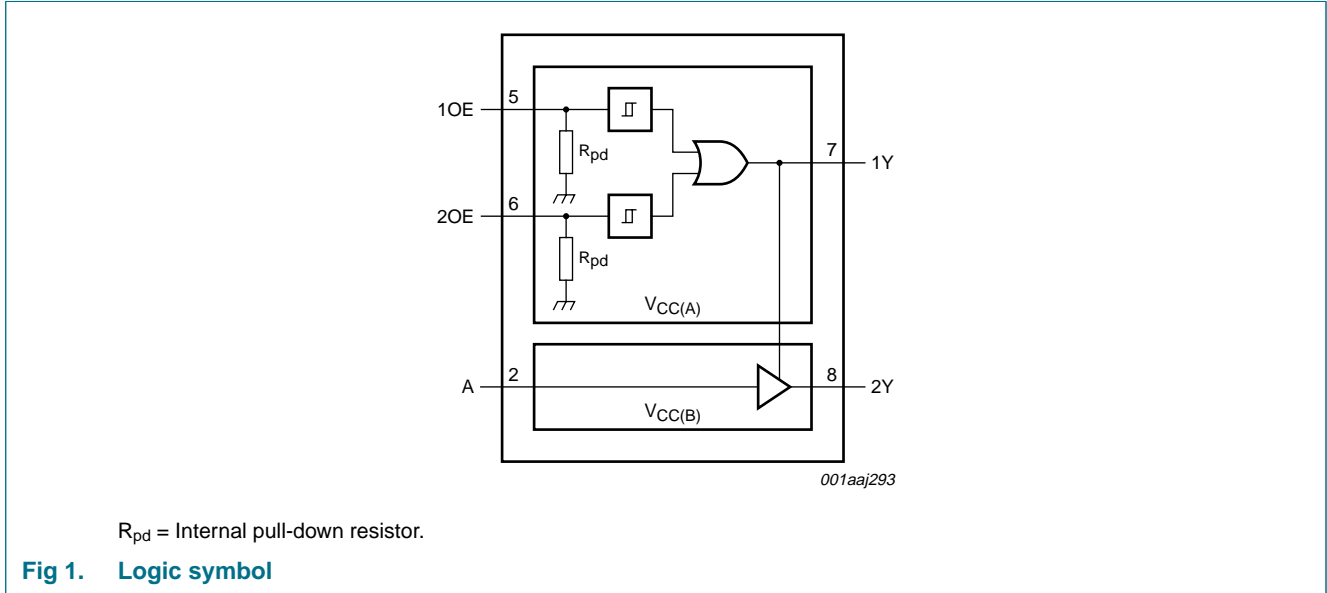

6. Pinning information

6.1 Pinning

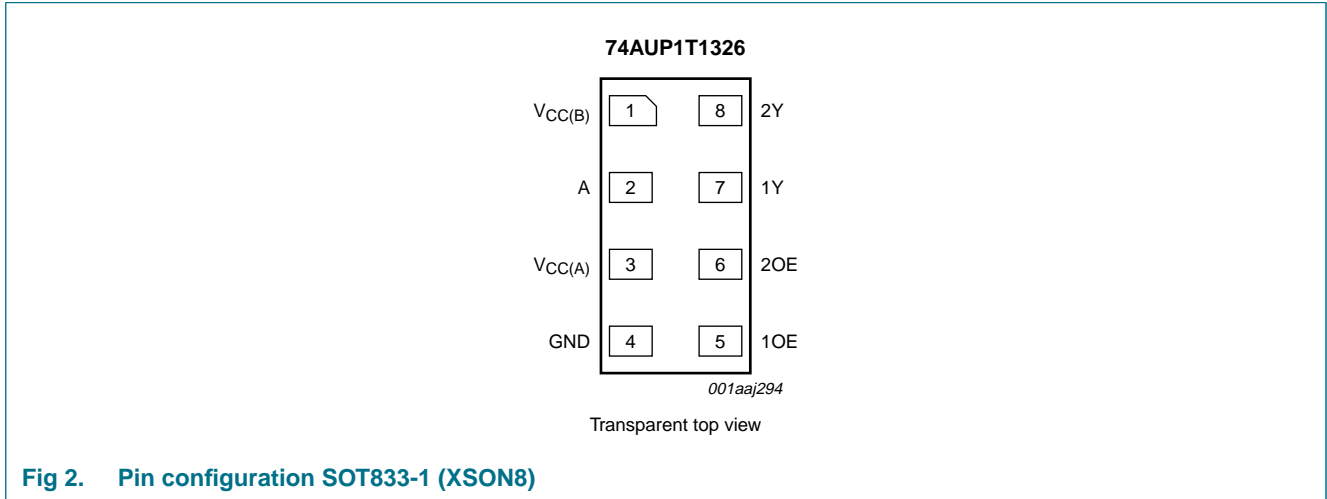

6.2 Pin description

Table 3. Pin description

Symbol	Pin	Description
V _{CC(B)}	1	supply voltage B
A	2	data input
V _{CC(A)}	3	supply voltage A
GND	4	ground (0 V)
1OE	5	output enable input (Schmitt trigger input)
2OE	6	output enable input (Schmitt trigger input)
1Y	7	data output
2Y	8	data output

7. Functional description

Table 4. Function table^[1]

Input			Output	
1OE	2OE	A	1Y	2Y
L	L	X	L	Z
X	H	L	H	L
X	H	H	H	H
H	X	L	H	L
H	X	H	H	H

[1] H = HIGH voltage level; L = LOW voltage level; X = don't care; Z = high-impedance OFF-state.

8. Limiting values

Table 5. Limiting values

In accordance with the Absolute Maximum Rating System (IEC 60134). Voltages are referenced to GND (ground = 0 V).

Symbol	Parameter	Conditions	Min	Max	Unit
$V_{CC(A)}$	supply voltage A		-0.5	+4.6	V
$V_{CC(B)}$	supply voltage B		-0.5	+4.6	V
I_{IK}	input clamping current	$V_I < 0$ V	-50	-	mA
V_I	input voltage		[1] -0.5	+4.6	V
I_{OK}	output clamping current	$V_O > V_{CCO}$ or $V_O < 0$ V	[2] -	-50	mA
V_O	output voltage	Active mode and Power-down mode	[1] -0.5	+4.6	V
I_O	output current	$V_O = 0$ V to V_{CCO}	[2] -	± 20	mA
I_{CC}	supply current		-	50	mA
I_{GND}	ground current		-50	-	mA
T_{stg}	storage temperature		-65	+150	°C
P_{tot}	total power dissipation	$T_{amb} = -40$ °C to +85 °C	[3] -	250	mW

[1] The minimum input and output voltage ratings may be exceeded if the input and output current ratings are observed.

[2] V_{CCO} is the supply voltage associated with an output pin.

[3] For XSON8 package: above 45 °C the value of P_{tot} derates linearly with 2.4 mW/K.

9. Recommended operating conditions

Table 6. Recommended operating conditions

Symbol	Parameter	Conditions	Min	Max	Unit
$V_{CC(A)}$	supply voltage A		1.1	3.6	V
$V_{CC(B)}$	supply voltage B		1.1	3.6	V
V_I	input voltage		0	3.6	V
V_O	output voltage		[1] 0	V_{CCO}	V
T_{amb}	ambient temperature		-40	+85	°C
$\Delta t/\Delta V$	input transition rise and fall rate	input A; $V_{CCI} = 1.1$ V to 3.6 V	[2] -	200	ns/V
		input nOE; $V_{CCI} = 1.1$ V to 3.6 V	[2] -	30	ms/V

[1] V_{CCO} is the supply voltage associated with an output pin.

[2] V_{CCI} is the supply voltage associated with an input pin.

10. Static characteristics

Table 7. Static characteristics

At recommended operating conditions; voltages are referenced to GND (ground = 0 V).

Symbol	Parameter	Conditions	25 °C			-40 °C to +85 °C		Unit
			Min	Typ	Max	Min	Max	
T_{amb} = 25 °C								
V _{IH}	HIGH-level input voltage	input A; [1][3]						
		V _{CCI} = 1.1 V to 1.95 V	0.65V _{CCI}	-	-	0.65V _{CCI}	-	V
		V _{CCI} = 2.3 V to 2.7 V	1.6	-	-	1.6	-	V
		V _{CCI} = 3.0 V to 3.6 V	2.0	-	-	2.0	-	V
V _{IL}	LOW-level input voltage	input A; [1][3]						
		V _{CCI} = 1.1 V to 1.95 V	-	-	0.35V _{CCI}	-	0.35V _{CCI}	V
		V _{CCI} = 2.3 V to 2.7 V	-	-	0.7	-	0.7	V
		V _{CCI} = 3.0 V to 3.6 V	-	-	0.9	-	0.9	V
V _{OH}	HIGH-level output voltage	V _I = V _{IL} or V _I or V _I = V _{T+} or V _{T-}						
		I _O = -20 μA; V _{CCO} = 1.1 V to 3.6 V [2]	V _{CCO} - 0.1	-	-	V _{CCO} - 0.1	-	V
		I _O = -1.1 mA; V _{CCO} = 1.1 V [2]	0.825	-	-	0.825	-	V
		I _O = -1.7 mA; V _{CCO} = 1.4 V	1.05	-	-	1.05	-	V
		I _O = -3 mA; V _{CCO} = 1.65 V	1.2	-	-	1.2	-	V
		I _O = -2.3 mA; V _{CCO} = 2.3 V	1.97	-	-	1.97	-	V
		I _O = -4.0 mA; V _{CCO} = 2.3 V	2.0	-	-	2.0	-	V
		I _O = -2.7 mA; V _{CCO} = 3.0 V	2.67	-	-	2.67	-	V
		I _O = -6.0 mA; V _{CCO} = 3.0 V	2.48	-	-	2.48	-	V
V _{OL}	LOW-level output voltage	V _I = V _{IL} or V _I or V _I = V _{T+} or V _{T-} [2]						
		I _O = 20 μA; V _{CCO} = 1.1 V to 3.6 V	-	-	0.10	-	0.10	V
		I _O = 1.1 mA; V _{CCO} = 1.1 V	-	-	0.275	-	0.275	V
		I _O = 1.7 mA; V _{CCO} = 1.4 V	-	-	0.35	-	0.35	V
		I _O = 3.0 mA; V _{CCO} = 1.65 V	-	-	0.45	-	0.45	V
		I _O = 2.3 mA; V _{CCO} = 2.3 V	-	-	0.33	-	0.33	V
		I _O = 4.0 mA; V _{CCO} = 2.3 V	-	-	0.40	-	0.40	V
		I _O = 2.7 mA; V _{CCO} = 3.0 V	-	-	0.33	-	0.33	V
		I _O = 6.0 mA; V _{CCO} = 3.0 V	-	-	0.40	-	0.40	V
I _I	input leakage current	input A; V _I = 0 V to 3.6 V; V _{CCI} = 1.1 V to 3.6 V [1]	-	-	±0.1	-	±0.5	μA
I _{OZ}	OFF-state output current	output 2Y; V _I = V _{IH} or V _{IL} ; V _O = 0 V to 3.6 V; V _{CC(A)} = 1.1 V to 3.6 V; V _{CC(B)} = 1.1 V to 3.6 V	-	-	±0.1	-	±0.5	μA

Table 7. Static characteristics ...continued

At recommended operating conditions; voltages are referenced to GND (ground = 0 V).

Symbol	Parameter	Conditions	25 °C			-40 °C to +85 °C		Unit
			Min	Typ	Max	Min	Max	
I _{OFF}	power-off leakage current	1Y; V _{CC(A)} = 0 V; V _O = 0 V to 3.6 V; V _{CC(B)} = 1.1 V to 3.6 V	-	-	±0.2	-	±0.5	µA
		A, 2Y; V _{CC(B)} = 0 V; V _I or V _O = 0 V to 3.6 V; V _{CC(A)} = 1.1 V to 3.6 V	-	-	±0.2	-	±0.5	µA
ΔI _{OFF}	additional power-off leakage current	1Y; V _{CC(A)} = 0 V to 0.2 V; V _O = 0 V to 3.6 V; V _{CC(B)} = 1.1 V to 3.6 V	-	-	±0.2	-	±0.6	µA
		A, 2Y; V _{CC(B)} = 0 V to 0.2 V; V _I or V _O = 0 V to 3.6 V; V _{CC(A)} = 1.1 V to 3.6 V	-	-	±0.2	-	±0.6	µA
I _{CC(A)}	supply current A	V _I = 0 V or V _{CC(A)} ; I _O = 0 A [1]	-	-	-	-	-	-
		V _{CC(A)} = 1.1 V to 3.6 V; V _{CC(B)} = 0 V to 3.6 V	-	-	0.5	-	0.9	µA
I _{CC(B)}	supply current B	V _I = 0 V or V _{CC(B)} ; I _O = 0 A [1]	-	-	-	-	-	-
		V _{CC(A)} = V _{CC(B)} = 1.1 V to 3.6 V	-	-	0.5	-	0.9	µA
		V _{CC(A)} = 1.71 V; V _{CC(B)} = 2.6 V	-	-	350	-	500	µA
ΔI _{CC}	additional supply current	nOE; V _{CC(A)} = V _{CC(B)} = 3.3 V; V _I = V _{CC(A)} - 0.6 V	-	-	40	-	50	µA
		A; V _{CC(A)} = V _{CC(B)} = 3.3 V; V _I = V _{CC(B)} - 0.6 V;	-	-	40	-	50	µA
		A; V _I = GND to 3.6 V; nOE = GND; V _{CC(A)} = V _{CC(B)} = 1.1 V to 3.6 V [4]	-	-	-	-	1	µA
R _{pd}	pull-down resistance		151	281	428	150	435	kΩ
C _I	input capacitance	input A; V _I = 0 V or V _{CC(I)} ; V _{CC(I)} = 1.1 V to 3.6 V [1]	-	0.9	-	-	-	pF
		input nOE; V _I = 0 V or V _{CC(I)} ; V _{CC(I)} = 1.1 V to 3.6 V [1]	-	0.8	-	-	-	pF
C _O	output capacitance	1Y; V _O = GND; V _{CCO} = 0 V [2]	-	1.7	-	-	-	pF
		2Y enabled; V _O = GND; V _{CCO} = 0 V [2]	-	1.7	-	-	-	pF
		2Y disabled; V _{CCO} = 0 V to 3.6 V; V _O = GND or V _{CCO} [2]	-	1.5	-	-	-	pF

[1] V_{CC(I)} is the supply voltage associated with the input pin.

[2] V_{CCO} is the supply voltage associated with the output pin.

[3] For V_{CC(I)} values not specified in the data sheet: minimum V_{IH} = 0.7 × V_{CC(I)} and maximum V_{IL} = 0.3 × V_{CC(I)}.

[4] To show I_{CC} remains very low when the input-disable feature is enabled.

11. Dynamic characteristics

Table 8. Dynamic characteristics

Voltages are referenced to GND (ground = 0 V); for test circuit see [Figure 5](#).

Symbol	Parameter	Conditions	25 °C			-40 °C to +85 °C		Unit		
			Min	Typ ^[1]	Max	Min	Max			
C_L = 5 pF										
t _{pd}	propagation delay	A to 2Y; see Figure 3	[2]							
		V _{CC(B)} = 1.1 V to 1.3 V	3.0	5.4	9.5	2.7	9.7	ns		
		V _{CC(B)} = 1.4 V to 1.6 V	2.4	3.8	5.7	2.1	6.1	ns		
		V _{CC(B)} = 1.65 V to 1.95 V	1.9	3.1	4.5	1.7	5.0	ns		
		V _{CC(B)} = 2.3 V to 2.7 V	1.5	2.3	3.4	1.3	3.8	ns		
		V _{CC(B)} = 3.0 V to 3.6 V	1.2	2.1	3.0	1.0	3.3	ns		
		nOE to 1Y; see Figure 3	[2]							
		V _{CC(A)} = 1.1 V to 1.3 V	3.4	5.6	9.3	3.2	9.5	ns		
		V _{CC(A)} = 1.4 V to 1.6 V	2.8	4.2	5.9	2.6	6.3	ns		
		V _{CC(A)} = 1.65 V to 1.95 V	2.4	3.5	4.9	2.2	5.3	ns		
		V _{CC(A)} = 2.3 V to 2.7 V	2.2	2.9	3.9	2.0	4.1	ns		
		V _{CC(A)} = 3.0 V to 3.6 V	1.9	2.6	3.4	1.8	3.7	ns		
		C_L = 10 pF								
		t _{pd}	propagation delay	A to 2Y; see Figure 3	[2]					
V _{CC(B)} = 1.1 V to 1.3 V	3.4			6.2	11.0	3.0	11.4	ns		
V _{CC(B)} = 1.4 V to 1.6 V	2.7			4.4	6.6	2.4	7.1	ns		
V _{CC(B)} = 1.65 V to 1.95 V	2.3			3.6	5.3	2.0	5.8	ns		
V _{CC(B)} = 2.3 V to 2.7 V	1.8			2.8	4.1	1.5	4.5	ns		
V _{CC(B)} = 3.0 V to 3.6 V	1.6			2.6	3.8	1.3	4.2	ns		
nOE to 1Y; see Figure 3	[2]									
V _{CC(A)} = 1.1 V to 1.3 V	3.7			6.4	10.8	3.4	11.1	ns		
V _{CC(A)} = 1.4 V to 1.6 V	3.1			4.7	6.8	2.8	7.2	ns		
V _{CC(A)} = 1.65 V to 1.95 V	2.9			4.0	5.6	2.5	6.1	ns		
V _{CC(A)} = 2.3 V to 2.7 V	2.5			3.4	4.6	2.2	4.9	ns		
V _{CC(A)} = 3.0 V to 3.6 V	2.3			3.1	4.1	2.1	4.5	ns		

Table 8. Dynamic characteristics ...continuedVoltages are referenced to GND (ground = 0 V); for test circuit see [Figure 5](#).

Symbol	Parameter	Conditions	25 °C			-40 °C to +85 °C		Unit		
			Min	Typ ^[1]	Max	Min	Max			
C_L = 15 pF										
t _{pd}	propagation delay	A to 2Y; see Figure 3	[2]							
		V _{CC(B)} = 1.1 V to 1.3 V	3.8	6.9	12.5	3.4	12.9	ns		
		V _{CC(B)} = 1.4 V to 1.6 V	3.2	4.9	7.5	2.8	8.1	ns		
		V _{CC(B)} = 1.65 V to 1.95 V	2.7	4.0	6.0	2.3	6.5	ns		
		V _{CC(B)} = 2.3 V to 2.7 V	2.2	3.2	4.8	1.8	5.3	ns		
		V _{CC(B)} = 3.0 V to 3.6 V	1.8	2.9	4.4	1.6	4.8	ns		
		nOE to 1Y; see Figure 3	[2]							
		V _{CC(A)} = 1.1 V to 1.3 V	4.2	7.2	12.4	3.8	12.7	ns		
		V _{CC(A)} = 1.4 V to 1.6 V	3.6	5.2	7.6	3.3	8.2	ns		
		V _{CC(A)} = 1.65 V to 1.95 V	3.1	4.5	6.3	2.7	6.9	ns		
		V _{CC(A)} = 2.3 V to 2.7 V	2.8	3.8	5.3	2.5	5.6	ns		
		V _{CC(A)} = 3.0 V to 3.6 V	2.5	3.5	4.8	2.3	5.2	ns		
		C_L = 30 pF								
		t _{pd}	propagation delay	A to 2Y; see Figure 3	[2]					
V _{CC(B)} = 1.1 V to 1.3 V	4.8			9.0	16.6	4.2	17.3	ns		
V _{CC(B)} = 1.4 V to 1.6 V	4.0			6.3	9.8	3.4	10.6	ns		
V _{CC(B)} = 1.65 V to 1.95 V	3.5			5.1	7.8	3.0	8.6	ns		
V _{CC(B)} = 2.3 V to 2.7 V	2.7			4.2	6.2	2.4	6.8	ns		
V _{CC(B)} = 3.0 V to 3.6 V	2.5			3.9	5.9	2.3	6.4	ns		
nOE to 1Y; see Figure 3	[2]									
V _{CC(A)} = 1.1 V to 1.3 V	5.1			9.2	16.4	4.6	17.1	ns		
V _{CC(A)} = 1.4 V to 1.6 V	4.3			6.6	9.9	3.8	10.8	ns		
V _{CC(A)} = 1.65 V to 1.95 V	4.0			5.6	8.1	3.5	8.9	ns		
V _{CC(A)} = 2.3 V to 2.7 V	3.4			4.7	6.7	3.0	7.2	ns		
V _{CC(A)} = 3.0 V to 3.6 V	3.3			4.4	6.2	3.0	6.7	ns		
C_L = 5 pF; V_{CC(A)} = 1.1 V to 1.3 V										
t _{en}	enable time			nOE to 2Y; see Figure 4	[3]					
		V _{CC(B)} = 1.1 V to 1.3 V	3.4	8.7	20.0	3.2	20.3	ns		
		V _{CC(B)} = 1.4 V to 1.6 V	2.8	7.0	15.6	2.5	15.8	ns		
t _{dis}	disable time	nOE to 2Y; see Figure 4	[4]							
		V _{CC(B)} = 1.1 V to 1.3 V	3.4	7.1	15.2	3.2	15.5	ns		
		V _{CC(B)} = 1.4 V to 1.6 V	2.8	6.1	13.5	2.5	13.9	ns		

Table 8. Dynamic characteristics ...continued
 Voltages are referenced to GND (ground = 0 V); for test circuit see [Figure 5](#).

Symbol	Parameter	Conditions	25 °C			-40 °C to +85 °C		Unit
			Min	Typ ^[1]	Max	Min	Max	
C_L = 5 pF; V_{CC(A)} = 1.4 V to 1.6 V								
t _{en}	enable time	nOE to 2Y; see Figure 4 ^[3]						
		V _{CC(B)} = 1.1 V to 1.3 V	3.4	7.8	16.6	3.1	17.1	ns
		V _{CC(B)} = 1.4 V to 1.6 V	2.8	6.1	12.2	2.5	12.6	ns
		V _{CC(B)} = 1.65 V to 1.95 V	2.4	5.4	10.7	2.1	11.1	ns
t _{dis}	disable time	nOE to 2Y; see Figure 4 ^[4]						
		V _{CC(B)} = 1.1 V to 1.3 V	3.4	6.3	11.8	3.1	12.3	ns
		V _{CC(B)} = 1.4 V to 1.6 V	2.8	5.3	10.1	2.5	10.7	ns
		V _{CC(B)} = 1.65 V to 1.95 V	2.4	5.4	9.9	2.1	10.5	ns
C_L = 5 pF; V_{CC(A)} = 1.65 V to 1.95 V								
t _{en}	enable time	nOE to 2Y; see Figure 4 ^[3]						
		V _{CC(B)} = 1.1 V to 1.3 V	3.4	7.4	15.6	3.1	16.0	ns
		V _{CC(B)} = 1.4 V to 1.6 V	2.8	5.6	11.2	2.5	11.5	ns
		V _{CC(B)} = 1.65 V to 1.95 V	2.4	4.9	9.7	2.1	10.1	ns
t _{dis}	disable time	nOE to 2Y; see Figure 4 ^[4]						
		V _{CC(B)} = 1.1 V to 1.3 V	3.4	6.0	10.8	3.1	11.2	ns
		V _{CC(B)} = 1.4 V to 1.6 V	2.8	5.0	9.1	2.5	9.6	ns
		V _{CC(B)} = 1.65 V to 1.95 V	2.4	5.1	8.9	2.1	9.4	ns
t _{en}	enable time	nOE to 2Y; see Figure 4 ^[3]						
		V _{CC(B)} = 1.1 V to 1.3 V	3.4	6.8	14.6	3.1	14.9	ns
		V _{CC(B)} = 1.4 V to 1.6 V	2.8	5.0	10.1	2.5	10.4	ns
		V _{CC(B)} = 1.65 V to 1.95 V	2.4	4.3	8.7	2.1	9.0	ns
t _{dis}	disable time	nOE to 2Y; see Figure 4 ^[4]						
		V _{CC(B)} = 1.1 V to 1.3 V	3.4	5.5	9.8	3.1	10.1	ns
		V _{CC(B)} = 1.4 V to 1.6 V	2.8	4.5	8.1	2.5	8.5	ns
		V _{CC(B)} = 1.65 V to 1.95 V	2.4	4.6	7.9	2.1	8.3	ns
t _{en}	enable time	nOE to 2Y; see Figure 4 ^[3]						
		V _{CC(B)} = 1.1 V to 1.3 V	3.4	6.8	14.6	3.1	14.9	ns
		V _{CC(B)} = 1.4 V to 1.6 V	2.8	5.0	10.1	2.5	10.4	ns
		V _{CC(B)} = 1.65 V to 1.95 V	2.4	4.3	8.7	2.1	9.0	ns
t _{dis}	disable time	nOE to 2Y; see Figure 4 ^[4]						
		V _{CC(B)} = 1.1 V to 1.3 V	3.4	5.5	9.8	3.1	10.1	ns
		V _{CC(B)} = 1.4 V to 1.6 V	2.8	4.5	8.1	2.5	8.5	ns
		V _{CC(B)} = 1.65 V to 1.95 V	2.4	4.6	7.9	2.1	8.3	ns
t _{en}	enable time	nOE to 2Y; see Figure 4 ^[3]						
		V _{CC(B)} = 1.1 V to 1.3 V	3.4	6.8	14.6	3.1	14.9	ns
		V _{CC(B)} = 1.4 V to 1.6 V	2.8	5.0	10.1	2.5	10.4	ns
		V _{CC(B)} = 1.65 V to 1.95 V	2.4	4.3	8.7	2.1	9.0	ns
t _{dis}	disable time	nOE to 2Y; see Figure 4 ^[4]						
		V _{CC(B)} = 1.1 V to 1.3 V	3.4	5.5	9.8	3.1	10.1	ns
		V _{CC(B)} = 1.4 V to 1.6 V	2.8	4.5	8.1	2.5	8.5	ns
		V _{CC(B)} = 1.65 V to 1.95 V	2.4	4.6	7.9	2.1	8.3	ns
t _{en}	enable time	nOE to 2Y; see Figure 4 ^[3]						
		V _{CC(B)} = 1.1 V to 1.3 V	3.4	6.8	14.6	3.1	14.9	ns
		V _{CC(B)} = 1.4 V to 1.6 V	2.8	5.0	10.1	2.5	10.4	ns
		V _{CC(B)} = 1.65 V to 1.95 V	2.4	4.3	8.7	2.1	9.0	ns
t _{dis}	disable time	nOE to 2Y; see Figure 4 ^[4]						
		V _{CC(B)} = 1.1 V to 1.3 V	3.4	5.5	9.8	3.1	10.1	ns
		V _{CC(B)} = 1.4 V to 1.6 V	2.8	4.5	8.1	2.5	8.5	ns
		V _{CC(B)} = 1.65 V to 1.95 V	2.4	4.6	7.9	2.1	8.3	ns
t _{en}	enable time	nOE to 2Y; see Figure 4 ^[3]						
		V _{CC(B)} = 1.1 V to 1.3 V	3.4	6.8	14.6	3.1	14.9	ns
		V _{CC(B)} = 1.4 V to 1.6 V	2.8	5.0	10.1	2.5	10.4	ns
		V _{CC(B)} = 1.65 V to 1.95 V	2.4	4.3	8.7	2.1	9.0	ns
t _{dis}	disable time	nOE to 2Y; see Figure 4 ^[4]						
		V _{CC(B)} = 1.1 V to 1.3 V	3.4	5.5	9.8	3.1	10.1	ns
		V _{CC(B)} = 1.4 V to 1.6 V	2.8	4.5	8.1	2.5	8.5	ns
		V _{CC(B)} = 1.65 V to 1.95 V	2.4	4.6	7.9	2.1	8.3	ns
t _{en}	enable time	nOE to 2Y; see Figure 4 ^[3]						
		V _{CC(B)} = 1.1 V to 1.3 V	3.4	6.8	14.6	3.1	14.9	ns
		V _{CC(B)} = 1.4 V to 1.6 V	2.8	5.0	10.1	2.5	10.4	ns
		V _{CC(B)} = 1.65 V to 1.95 V	2.4	4.3	8.7	2.1	9.0	ns
t _{dis}	disable time	nOE to 2Y; see Figure 4 ^[4]						
		V _{CC(B)} = 1.1 V to 1.3 V	3.4	5.5	9.8	3.1	10.1	ns
		V _{CC(B)} = 1.4 V to 1.6 V	2.8	4.5	8.1	2.5	8.5	ns
		V _{CC(B)} = 1.65 V to 1.95 V	2.4	4.6	7.9	2.1	8.3	ns
t _{en}	enable time	nOE to 2Y; see Figure 4 ^[3]						
		V _{CC(B)} = 1.1 V to 1.3 V	3.4	6.8	14.6	3.1	14.9	ns
		V _{CC(B)} = 1.4 V to 1.6 V	2.8	5.0	10.1	2.5	10.4	ns
		V _{CC(B)} = 1.65 V to 1.95 V	2.4	4.3	8.7	2.1	9.0	ns
t _{dis}	disable time	nOE to 2Y; see Figure 4 ^[4]						
		V _{CC(B)} = 1.1 V to 1.3 V	3.4	5.5	9.8	3.1	10.1	ns
		V _{CC(B)} = 1.4 V to 1.6 V	2.8	4.5	8.1	2.5	8.5	ns
		V _{CC(B)} = 1.65 V to 1.95 V	2.4	4.6	7.9	2.1	8.3	ns

Table 8. Dynamic characteristics ...continued
 Voltages are referenced to GND (ground = 0 V); for test circuit see [Figure 5](#).

Symbol	Parameter	Conditions	25 °C			-40 °C to +85 °C		Unit
			Min	Typ ^[1]	Max	Min	Max	
C_L = 5 pF; V_{CC(A)} = 3.0 V to 3.6 V								
t _{en}	enable time	nOE to 2Y; see Figure 4 ^[3]						
		V _{CC(B)} = 1.1 V to 1.3 V	3.4	6.5	14.2	3.1	14.4	ns
		V _{CC(B)} = 1.4 V to 1.6 V	2.8	4.8	9.7	2.5	9.9	ns
		V _{CC(B)} = 1.65 V to 1.95 V	2.4	4.1	8.2	2.1	8.5	ns
		V _{CC(B)} = 2.3 V to 2.7 V	2.2	3.4	6.7	1.9	7.2	ns
		V _{CC(B)} = 3.0 V to 3.6 V	1.9	3.2	6.3	1.6	6.8	ns
t _{dis}	disable time	nOE to 2Y; see Figure 4 ^[4]						
		V _{CC(B)} = 1.1 V to 1.3 V	3.4	5.3	9.3	3.1	9.7	ns
		V _{CC(B)} = 1.4 V to 1.6 V	2.8	4.3	7.7	2.5	8.0	ns
		V _{CC(B)} = 1.65 V to 1.95 V	2.4	4.4	7.4	2.1	7.9	ns
		V _{CC(B)} = 2.3 V to 2.7 V	2.2	3.7	6.4	1.9	6.8	ns
		V _{CC(B)} = 3.0 V to 3.6 V	1.9	4.2	6.9	1.6	7.2	ns
C_L = 10 pF; V_{CC(A)} = 1.1 V to 1.3 V								
t _{en}	enable time	nOE to 2Y; see Figure 4 ^[3]						
		V _{CC(B)} = 1.1 V to 1.3 V	3.7	9.9	22.9	3.3	23.1	ns
		V _{CC(B)} = 1.4 V to 1.6 V	3.1	8.0	17.8	2.8	18.1	ns
t _{dis}	disable time	nOE to 2Y; see Figure 4 ^[4]						
		V _{CC(B)} = 1.1 V to 1.3 V	3.7	8.5	18.0	3.3	18.3	ns
		V _{CC(B)} = 1.4 V to 1.6 V	3.1	7.3	16.0	2.8	16.4	ns
C_L = 10 pF; V_{CC(A)} = 1.4 V to 1.6 V								
t _{en}	enable time	nOE to 2Y; see Figure 4 ^[3]						
		V _{CC(B)} = 1.1 V to 1.3 V	3.7	8.8	18.8	3.3	19.3	ns
		V _{CC(B)} = 1.4 V to 1.6 V	3.1	6.9	13.8	2.8	14.2	ns
		V _{CC(B)} = 1.65 V to 1.95 V	2.9	6.1	12.2	2.5	12.9	ns
t _{dis}	disable time	nOE to 2Y; see Figure 4 ^[4]						
		V _{CC(B)} = 1.1 V to 1.3 V	3.7	7.6	14.0	3.3	14.5	ns
		V _{CC(B)} = 1.4 V to 1.6 V	3.1	6.4	11.9	2.8	12.5	ns
		V _{CC(B)} = 1.65 V to 1.95 V	2.9	6.7	12.0	2.5	12.6	ns
C_L = 10 pF; V_{CC(A)} = 1.65 V to 1.95 V								
t _{en}	enable time	nOE to 2Y; see Figure 4 ^[3]						
		V _{CC(B)} = 1.1 V to 1.3 V	3.7	8.3	17.6	3.3	18.1	ns
		V _{CC(B)} = 1.4 V to 1.6 V	3.1	6.4	12.6	2.8	13.1	ns
		V _{CC(B)} = 1.65 V to 1.95 V	2.9	5.6	11.0	2.5	11.7	ns
		V _{CC(B)} = 2.3 V to 2.7 V	2.5	5.1	9.7	2.2	10.5	ns

Table 8. Dynamic characteristics ...continued
 Voltages are referenced to GND (ground = 0 V); for test circuit see [Figure 5](#).

Symbol	Parameter	Conditions	25 °C			-40 °C to +85 °C		Unit
			Min	Typ ^[1]	Max	Min	Max	
t _{dis}	disable time	nOE to 2Y; see Figure 4 ^[4]						
		V _{CC(B)} = 1.1 V to 1.3 V	3.7	7.2	12.8	3.3	13.4	ns
		V _{CC(B)} = 1.4 V to 1.6 V	3.1	6.0	10.8	2.8	11.4	ns
		V _{CC(B)} = 1.65 V to 1.95 V	2.9	6.3	10.8	2.5	11.5	ns
		V _{CC(B)} = 2.3 V to 2.7 V	2.5	5.2	9.5	2.2	10.1	ns

C_L = 10 pF; V_{CC(A)} = 2.3 V to 2.7 V

t _{en}	enable time	nOE to 2Y; see Figure 4 ^[3]						
		V _{CC(B)} = 1.1 V to 1.3 V	3.7	7.7	16.6	3.3	16.9	ns
		V _{CC(B)} = 1.4 V to 1.6 V	3.1	5.8	11.6	2.8	11.9	ns
		V _{CC(B)} = 1.65 V to 1.95 V	2.9	5.0	10.0	2.5	10.5	ns
		V _{CC(B)} = 2.3 V to 2.7 V	2.5	4.4	8.7	2.2	9.3	ns
		V _{CC(B)} = 3.0 V to 3.6 V	2.3	4.3	8.3	2.1	8.8	ns

t _{dis}	disable time	nOE to 2Y; see Figure 4 ^[4]						
		V _{CC(B)} = 1.1 V to 1.3 V	3.7	6.8	11.8	3.3	12.2	ns
		V _{CC(B)} = 1.4 V to 1.6 V	3.1	5.6	9.7	2.8	10.2	ns
		V _{CC(B)} = 1.65 V to 1.95 V	2.9	5.9	9.8	2.5	10.3	ns
		V _{CC(B)} = 2.3 V to 2.7 V	2.5	4.8	8.4	2.2	8.9	ns
		V _{CC(B)} = 3.0 V to 3.6 V	2.3	5.8	9.4	2.1	9.8	ns

C_L = 10 pF; V_{CC(A)} = 3.0 V to 3.6 V

t _{en}	enable time	nOE to 2Y; see Figure 4 ^[3]						
		V _{CC(B)} = 1.1 V to 1.3 V	3.7	7.4	16.1	3.3	16.5	ns
		V _{CC(B)} = 1.4 V to 1.6 V	3.1	5.5	11.1	2.8	11.5	ns
		V _{CC(B)} = 1.65 V to 1.95 V	2.9	4.7	9.5	2.5	10.1	ns
		V _{CC(B)} = 2.3 V to 2.7 V	2.5	4.1	8.3	2.2	8.8	ns
		V _{CC(B)} = 3.0 V to 3.6 V	2.3	3.9	7.8	2.1	8.3	ns

t _{dis}	disable time	nOE to 2Y; see Figure 4 ^[4]						
		V _{CC(B)} = 1.1 V to 1.3 V	3.7	6.6	11.3	3.3	11.7	ns
		V _{CC(B)} = 1.4 V to 1.6 V	3.1	5.4	9.3	2.8	9.7	ns
		V _{CC(B)} = 1.65 V to 1.95 V	2.9	5.7	9.4	2.5	9.8	ns
		V _{CC(B)} = 2.3 V to 2.7 V	2.5	4.6	8.0	2.2	8.5	ns
		V _{CC(B)} = 3.0 V to 3.6 V	2.3	5.6	9.0	2.1	9.4	ns

C_L = 15 pF; V_{CC(A)} = 1.1 V to 1.3 V

t _{en}	enable time	nOE to 2Y; see Figure 4 ^[3]						
		V _{CC(B)} = 1.1 V to 1.3 V	4.2	10.9	25.5	3.8	25.9	ns
		V _{CC(B)} = 1.4 V to 1.6 V	3.6	8.9	20.1	3.2	20.6	ns
t _{dis}	disable time	nOE to 2Y; see Figure 4 ^[4]						
		V _{CC(B)} = 1.1 V to 1.3 V	4.2	9.9	20.8	3.8	21.1	ns
		V _{CC(B)} = 1.4 V to 1.6 V	3.6	8.4	18.4	3.2	18.9	ns

Table 8. Dynamic characteristics ...continued
 Voltages are referenced to GND (ground = 0 V); for test circuit see [Figure 5](#).

Symbol	Parameter	Conditions	25 °C			-40 °C to +85 °C		Unit
			Min	Typ ^[1]	Max	Min	Max	
C_L = 15 pF; V_{CC(A)} = 1.4 V to 1.6 V								
t _{en}	enable time	nOE to 2Y; see Figure 4 ^[3]						
		V _{CC(B)} = 1.1 V to 1.3 V	4.2	9.7	20.8	3.8	21.4	ns
		V _{CC(B)} = 1.4 V to 1.6 V	3.6	7.6	15.3	3.2	16.1	ns
		V _{CC(B)} = 1.65 V to 1.95 V	3.1	6.8	13.6	2.7	14.5	ns
t _{dis}	disable time	nOE to 2Y; see Figure 4 ^[4]						
		V _{CC(B)} = 1.1 V to 1.3 V	4.2	8.9	16.0	3.8	16.6	ns
		V _{CC(B)} = 1.4 V to 1.6 V	3.6	7.4	13.7	3.2	14.4	ns
		V _{CC(B)} = 1.65 V to 1.95 V	3.1	8.0	14.1	2.7	14.8	ns
C_L = 15 pF; V_{CC(A)} = 1.65 V to 1.95 V								
t _{en}	enable time	nOE to 2Y; see Figure 4 ^[3]						
		V _{CC(B)} = 1.1 V to 1.3 V	4.2	9.1	19.5	3.8	20.1	ns
		V _{CC(B)} = 1.4 V to 1.6 V	3.6	7.0	14.0	3.1	14.7	ns
		V _{CC(B)} = 1.65 V to 1.95 V	3.1	6.2	12.2	2.7	13.2	ns
t _{dis}	disable time	nOE to 2Y; see Figure 4 ^[4]						
		V _{CC(B)} = 1.1 V to 1.3 V	4.2	8.5	14.7	3.8	15.3	ns
		V _{CC(B)} = 1.4 V to 1.6 V	3.6	7.0	12.4	3.1	13.1	ns
		V _{CC(B)} = 1.65 V to 1.95 V	3.1	7.5	12.7	2.7	13.5	ns
t _{dis}	disable time	nOE to 2Y; see Figure 4 ^[4]						
		V _{CC(B)} = 2.3 V to 2.7 V	2.8	5.6	11.0	2.4	11.8	ns
		V _{CC(B)} = 2.3 V to 2.7 V	2.8	6.1	11.0	2.4	11.8	ns
		V _{CC(B)} = 2.3 V to 2.7 V	2.8	6.1	11.0	2.4	11.8	ns
C_L = 15 pF; V_{CC(A)} = 2.3 V to 2.7 V								
t _{en}	enable time	nOE to 2Y; see Figure 4 ^[3]						
		V _{CC(B)} = 1.1 V to 1.3 V	4.2	8.5	18.4	3.8	18.8	ns
		V _{CC(B)} = 1.4 V to 1.6 V	3.6	6.4	13.0	3.2	13.5	ns
		V _{CC(B)} = 1.65 V to 1.95 V	3.1	5.6	11.2	2.7	11.9	ns
		V _{CC(B)} = 2.3 V to 2.7 V	2.8	4.9	10.0	2.5	10.6	ns
t _{dis}	disable time	nOE to 2Y; see Figure 4 ^[4]						
		V _{CC(B)} = 2.3 V to 2.7 V	2.5	4.8	9.6	2.3	10.1	ns
		V _{CC(B)} = 3.0 V to 3.6 V	2.5	4.8	9.6	2.3	10.1	ns
		V _{CC(B)} = 1.1 V to 1.3 V	4.2	8.0	13.6	3.8	14.0	ns
		V _{CC(B)} = 1.4 V to 1.6 V	3.6	6.6	11.3	3.2	11.8	ns
t _{dis}	disable time	nOE to 2Y; see Figure 4 ^[4]						
		V _{CC(B)} = 1.65 V to 1.95 V	3.1	7.1	11.7	2.7	12.3	ns
		V _{CC(B)} = 2.3 V to 2.7 V	2.8	5.7	10.0	2.5	10.5	ns
		V _{CC(B)} = 2.3 V to 2.7 V	2.8	5.7	10.0	2.5	10.5	ns
		V _{CC(B)} = 3.0 V to 3.6 V	2.5	7.1	11.5	2.3	11.9	ns

Table 8. Dynamic characteristics ...continued
 Voltages are referenced to GND (ground = 0 V); for test circuit see [Figure 5](#).

Symbol	Parameter	Conditions	25 °C			-40 °C to +85 °C		Unit
			Min	Typ ^[1]	Max	Min	Max	
$C_L = 15 \text{ pF}$; $V_{CC(A)} = 3.0 \text{ V to } 3.6 \text{ V}$								
t_{en}	enable time	nOE to 2Y; see Figure 4 ^[3]						
		$V_{CC(B)} = 1.1 \text{ V to } 1.3 \text{ V}$	4.2	8.2	18.0	3.8	18.4	ns
		$V_{CC(B)} = 1.4 \text{ V to } 1.6 \text{ V}$	3.6	6.1	12.5	3.2	13.0	ns
		$V_{CC(B)} = 1.65 \text{ V to } 1.95 \text{ V}$	3.1	5.2	10.7	2.7	11.5	ns
		$V_{CC(B)} = 2.3 \text{ V to } 2.7 \text{ V}$	2.8	4.6	9.5	2.5	10.1	ns
		$V_{CC(B)} = 3.0 \text{ V to } 3.6 \text{ V}$	2.5	4.4	9.1	2.3	9.6	ns
t_{dis}	disable time	nOE to 2Y; see Figure 4 ^[4]						
		$V_{CC(B)} = 1.1 \text{ V to } 1.3 \text{ V}$	4.2	7.8	13.2	3.8	13.6	ns
		$V_{CC(B)} = 1.4 \text{ V to } 1.6 \text{ V}$	3.6	6.3	10.9	3.2	11.4	ns
		$V_{CC(B)} = 1.65 \text{ V to } 1.95 \text{ V}$	3.1	6.9	11.3	2.7	11.8	ns
		$V_{CC(B)} = 2.3 \text{ V to } 2.7 \text{ V}$	2.8	5.5	9.5	2.5	10.0	ns
		$V_{CC(B)} = 3.0 \text{ V to } 3.6 \text{ V}$	2.5	6.8	11.0	2.3	11.5	ns
$C_L = 30 \text{ pF}$; $V_{CC(A)} = 1.1 \text{ V to } 1.3 \text{ V}$								
t_{en}	enable time	nOE to 2Y; see Figure 4 ^[3]						
		$V_{CC(B)} = 1.1 \text{ V to } 1.3 \text{ V}$	5.1	13.8	33.1	4.6	33.8	ns
		$V_{CC(B)} = 1.4 \text{ V to } 1.6 \text{ V}$	4.3	11.2	26.1	3.8	27.7	ns
t_{dis}	disable time	nOE to 2Y; see Figure 4 ^[4]						
		$V_{CC(B)} = 1.1 \text{ V to } 1.3 \text{ V}$	5.1	13.9	28.5	4.6	29.2	ns
		$V_{CC(B)} = 1.4 \text{ V to } 1.6 \text{ V}$	4.3	11.7	25.4	3.8	26.2	ns
$C_L = 30 \text{ pF}$; $V_{CC(A)} = 1.4 \text{ V to } 1.6 \text{ V}$								
t_{en}	enable time	nOE to 2Y; see Figure 4 ^[3]						
		$V_{CC(B)} = 1.1 \text{ V to } 1.3 \text{ V}$	5.1	12.1	26.6	4.6	27.5	ns
		$V_{CC(B)} = 1.4 \text{ V to } 1.6 \text{ V}$	4.3	9.5	19.6	3.8	21.4	ns
		$V_{CC(B)} = 1.65 \text{ V to } 1.95 \text{ V}$	4.0	8.5	17.7	3.5	19.2	ns
t_{dis}	disable time	nOE to 2Y; see Figure 4 ^[4]						
		$V_{CC(B)} = 1.1 \text{ V to } 1.3 \text{ V}$	5.1	12.6	22.0	4.6	22.9	ns
		$V_{CC(B)} = 1.4 \text{ V to } 1.6 \text{ V}$	4.3	10.4	18.9	3.8	19.9	ns
		$V_{CC(B)} = 1.65 \text{ V to } 1.95 \text{ V}$	4.0	11.6	20.1	3.5	21.2	ns
$C_L = 30 \text{ pF}$; $V_{CC(A)} = 1.65 \text{ V to } 1.95 \text{ V}$								
t_{en}	enable time	nOE to 2Y; see Figure 4 ^[3]						
		$V_{CC(B)} = 1.1 \text{ V to } 1.3 \text{ V}$	5.1	11.4	24.8	4.6	25.6	ns
		$V_{CC(B)} = 1.4 \text{ V to } 1.6 \text{ V}$	4.3	8.7	17.8	3.8	19.5	ns
		$V_{CC(B)} = 1.65 \text{ V to } 1.95 \text{ V}$	4.0	7.7	15.9	3.5	17.3	ns
		$V_{CC(B)} = 2.3 \text{ V to } 2.7 \text{ V}$	3.4	7.1	14.3	3.1	15.3	ns

Table 8. Dynamic characteristics ...continued
 Voltages are referenced to GND (ground = 0 V); for test circuit see [Figure 5](#).

Symbol	Parameter	Conditions	25 °C			-40 °C to +85 °C		Unit
			Min	Typ ^[1]	Max	Min	Max	
t _{dis}	disable time	nOE to 2Y; see Figure 4 ^[4]						
		V _{CC(B)} = 1.1 V to 1.3 V	5.1	12.0	20.2	4.6	21.0	ns
		V _{CC(B)} = 1.4 V to 1.6 V	4.3	9.9	17.1	3.8	18.0	ns
		V _{CC(B)} = 1.65 V to 1.95 V	4.0	11.1	18.3	3.5	19.3	ns
		V _{CC(B)} = 2.3 V to 2.7 V	3.4	8.7	15.5	3.2	16.4	ns
C_L = 30 pF; V_{CC(A)} = 2.3 V to 2.7 V								
t _{en}	enable time	nOE to 2Y; see Figure 4 ^[3]						
		V _{CC(B)} = 1.1 V to 1.3 V	5.1	10.6	23.3	4.6	23.9	ns
		V _{CC(B)} = 1.4 V to 1.6 V	4.3	7.9	16.4	3.8	17.8	ns
		V _{CC(B)} = 1.65 V to 1.95 V	4.0	6.9	14.4	3.5	15.6	ns
		V _{CC(B)} = 2.3 V to 2.7 V	3.4	6.2	12.8	3.2	13.6	ns
t _{dis}	disable time	nOE to 2Y; see Figure 4 ^[4]						
		V _{CC(B)} = 1.1 V to 1.3 V	5.1	11.5	18.7	4.6	19.3	ns
		V _{CC(B)} = 1.4 V to 1.6 V	4.3	9.3	15.6	3.8	16.3	ns
		V _{CC(B)} = 1.65 V to 1.95 V	4.0	10.5	16.8	3.5	17.5	ns
		V _{CC(B)} = 2.3 V to 2.7 V	3.4	8.2	14.0	3.2	14.7	ns
t _{en}	enable time	nOE to 2Y; see Figure 4 ^[3]						
		V _{CC(B)} = 1.1 V to 1.3 V	5.1	10.2	22.9	4.6	23.4	ns
		V _{CC(B)} = 1.4 V to 1.6 V	4.3	7.6	15.9	3.8	17.2	ns
		V _{CC(B)} = 1.65 V to 1.95 V	4.0	6.6	14.0	3.5	15.1	ns
		V _{CC(B)} = 2.3 V to 2.7 V	3.4	5.8	12.4	3.2	13.1	ns
t _{dis}	disable time	nOE to 2Y; see Figure 4 ^[4]						
		V _{CC(B)} = 1.1 V to 1.3 V	5.1	11.2	18.3	4.6	18.8	ns
		V _{CC(B)} = 1.4 V to 1.6 V	4.3	9.1	15.2	3.8	15.8	ns
		V _{CC(B)} = 1.65 V to 1.95 V	4.0	10.2	16.4	3.5	17.0	ns
		V _{CC(B)} = 2.3 V to 2.7 V	3.4	7.9	13.6	3.2	14.2	ns
t _{en}	enable time	nOE to 2Y; see Figure 4 ^[3]						
		V _{CC(B)} = 1.1 V to 1.3 V	5.1	10.5	16.5	3.1	17.1	ns
		V _{CC(B)} = 1.4 V to 1.6 V	4.3	7.9	13.6	3.2	14.2	ns
		V _{CC(B)} = 1.65 V to 1.95 V	4.0	10.2	16.4	3.5	17.0	ns
		V _{CC(B)} = 2.3 V to 2.7 V	3.4	7.9	13.6	3.2	14.2	ns

Table 8. Dynamic characteristics ...continued
 Voltages are referenced to GND (ground = 0 V); for test circuit see [Figure 5](#).

Symbol	Parameter	Conditions	25 °C			-40 °C to +85 °C		Unit
			Min	Typ ^[1]	Max	Min	Max	
C_L = 5 pF, 10 pF, 15 pF and 30 pF								
C _{PD}	power dissipation capacitance	output 2Y; f _i = 1 MHz; V _I = 0 V to V _{CC} ^[5]						
		V _{CC(A)} = V _{CC(B)} = 1.2 V	-	2.8	-	-	-	pF
		V _{CC(A)} = V _{CC(B)} = 1.5 V	-	3.0	-	-	-	pF
		V _{CC(A)} = V _{CC(B)} = 1.8 V	-	3.0	-	-	-	pF
		V _{CC(A)} = V _{CC(B)} = 2.5 V	-	3.6	-	-	-	pF
		V _{CC(A)} = V _{CC(B)} = 3.3 V	-	4.1	-	-	-	pF

- [1] All typical values are measured at nominal V_{CC(A)} and V_{CC(B)}.
- [2] t_{pd} is the same as t_{PLH} and t_{PHL}.
- [3] t_{en} is the same as t_{PZH} and t_{PZL}.
- [4] t_{dis} is the same as t_{PHZ} and t_{PLZ}.
- [5] C_{PD} is used to determine the dynamic power dissipation (P_D in μW).
 $P_D = C_{PD} \times V_{CC}^2 \times f_i \times N + \Sigma(C_L \times V_{CC}^2 \times f_o)$ where:
 f_i = input frequency in MHz;
 f_o = output frequency in MHz;
 C_L = load capacitance in pF;
 V_{CC} = supply voltage in V;
 N = number of inputs switching;
 Σ(C_L × V_{CC}² × f_o) = sum of the outputs.

12. Waveforms

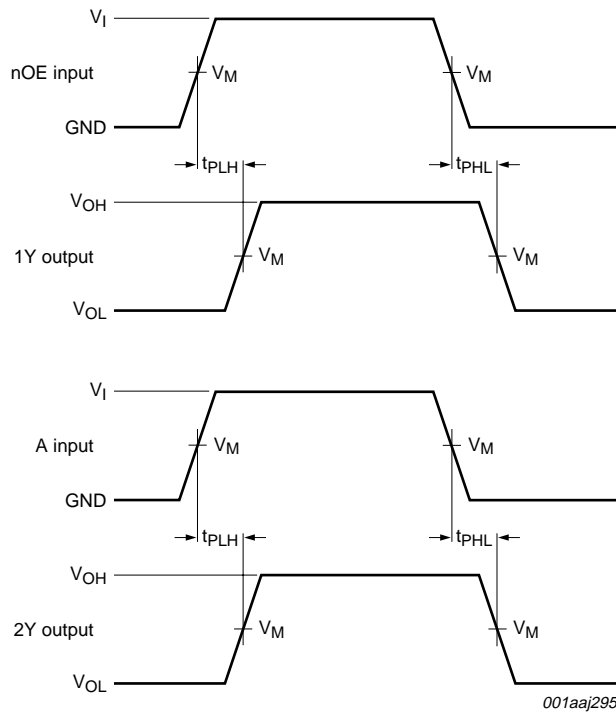

Measurement points are given in [Table 9](#).

V_{OL} and V_{OH} are typical output voltage levels that occur with the output load.

Fig 3. Input nOE to output 1Y and A to output 2Y propagation delay times

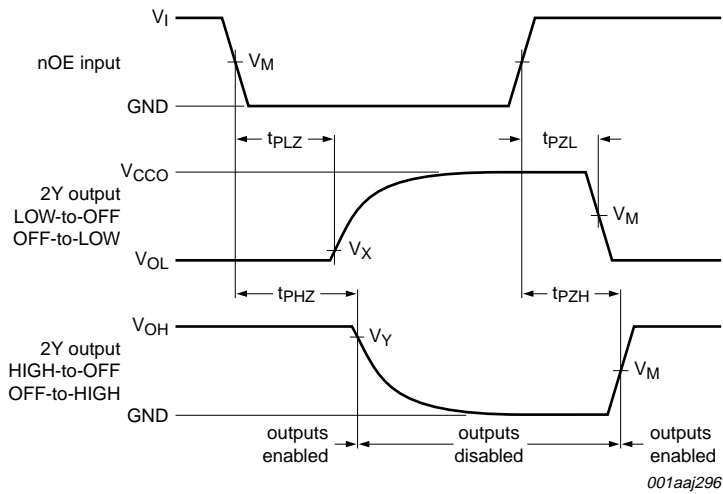

Measurement points are given in [Table 9](#).
 V_{OL} and V_{OH} are typical output voltage levels that occur with the output load.
 V_{CC0} is the supply voltage associated with the output pin.
 Output 1Y has no external load.

Fig 4. Enable and disable times

Table 9. Measurement points

Supply voltage	Input ^[1]	Output ^[2]		
$V_{CC(A)}, V_{CC(B)}$	V_M	V_M	V_X	V_Y
1.1 V to 1.6 V	$0.5V_{CCI}$	$0.5V_{CC0}$	$V_{OL} + 0.1\text{ V}$	$V_{OH} - 0.1\text{ V}$
1.65 V to 2.7 V	$0.5V_{CCI}$	$0.5V_{CC0}$	$V_{OL} + 0.15\text{ V}$	$V_{OH} - 0.15\text{ V}$
3.0 V to 3.6 V	$0.5V_{CCI}$	$0.5V_{CC0}$	$V_{OL} + 0.3\text{ V}$	$V_{OH} - 0.3\text{ V}$

[1] V_{CCI} is the supply voltage associated with the data input port.

[2] V_{CC0} is the supply voltage associated with the output port.

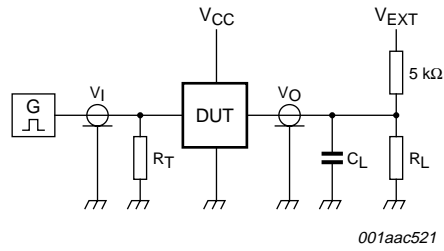

Test data is given in [Table 10](#).

Definitions for test circuit:

R_L = Load resistance.

C_L = Load capacitance including jig and probe capacitance.

R_T = Termination resistance should be equal to the output impedance Z_o of the pulse generator.

V_{EXT} = External voltage for measuring switching times.

Fig 5. Load circuit for switching times

Table 10. Test data

Supply voltage	Input		Load ^[2]	V_{EXT}			
$V_{CC(A)}, V_{CC(B)}$	V_I ^[1]	$t_r = t_f$	C_L	R_L ^[3]	t_{PLH}, t_{PHL}	t_{PZH}, t_{PHZ}	t_{PZL}, t_{PLZ} ^[4]
1.1 V to 3.6 V	V_{CCI}	≤ 3.0 ns	5 pF, 10 pF, 15 pF and 30 pF	5 kΩ or 1 MΩ	open	GND	$2V_{CCO}$

[1] V_{CCI} is the supply voltage associated with the data input port.

[2] For measuring enable and disable times, C_L and R_L are connected to pin 2Y. Pin 1Y has no load.

[3] For measuring enable and disable times $R_L = 5$ kΩ, for measuring propagation delays $R_L = 1$ MΩ.

[4] V_{CCO} is the supply voltage associated with the output port.

13. Transfer characteristics

Table 11. Transfer characteristics

Voltages are referenced to GND (ground = 0 V; for test circuit see [Figure 5](#)).

Symbol	Parameter	Conditions	25 °C			-40 °C to +85 °C		Unit
			Min	Typ	Max	Min	Max	
V _{T+}	positive-going threshold voltage	nOE inputs; see Figure 6 and Figure 7						
		V _{CC(A)} = 1.1 V	0.53	-	0.90	0.53	0.90	V
		V _{CC(A)} = 1.4 V	0.74	-	1.11	0.74	1.11	V
		V _{CC(A)} = 1.65 V	0.91	-	1.29	0.91	1.29	V
		V _{CC(A)} = 2.3 V	1.37	-	1.77	1.37	1.77	V
		V _{CC(A)} = 3.0 V	1.88	-	2.29	1.88	2.29	V
V _{T-}	negative-going threshold voltage	nOE inputs; see Figure 6 and Figure 7						
		V _{CC(A)} = 1.1 V	0.26	-	0.65	0.26	0.65	V
		V _{CC(A)} = 1.4 V	0.39	-	0.75	0.39	0.75	V
		V _{CC(A)} = 1.65 V	0.47	-	0.84	0.47	0.84	V
		V _{CC(A)} = 2.3 V	0.69	-	1.04	0.69	1.04	V
		V _{CC(A)} = 3.0 V	0.88	-	1.24	0.88	1.24	V
V _H	hysteresis voltage	nOE inputs; (V _{T+} - V _{T-}); see Figure 6 , Figure 7 , Figure 8 and Figure 9						
		V _{CC(A)} = 1.1 V	0.08	-	0.46	0.08	0.46	V
		V _{CC(A)} = 1.4 V	0.18	-	0.56	0.18	0.56	V
		V _{CC(A)} = 1.65 V	0.27	-	0.66	0.27	0.66	V
		V _{CC(A)} = 2.3 V	0.53	-	0.92	0.53	0.92	V
		V _{CC(A)} = 3.0 V	0.79	-	1.31	0.79	1.31	V

14. Waveforms transfer characteristics

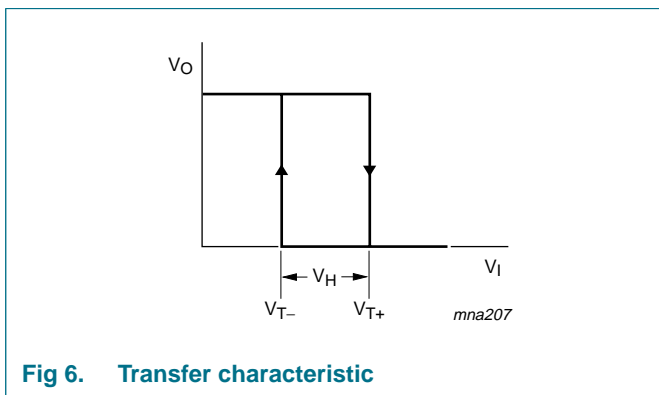

Fig 6. Transfer characteristic

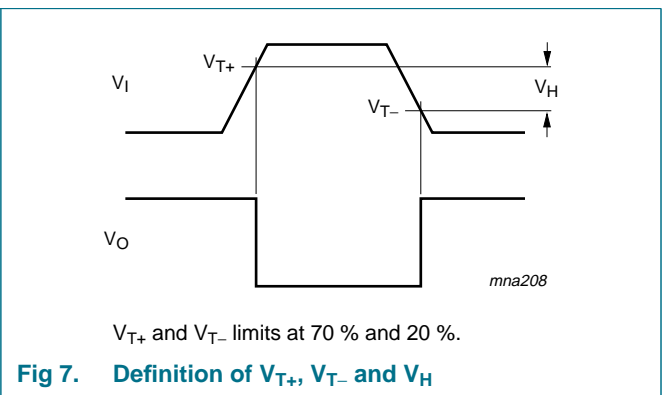

Fig 7. Definition of V_{T+}, V_{T-} and V_H

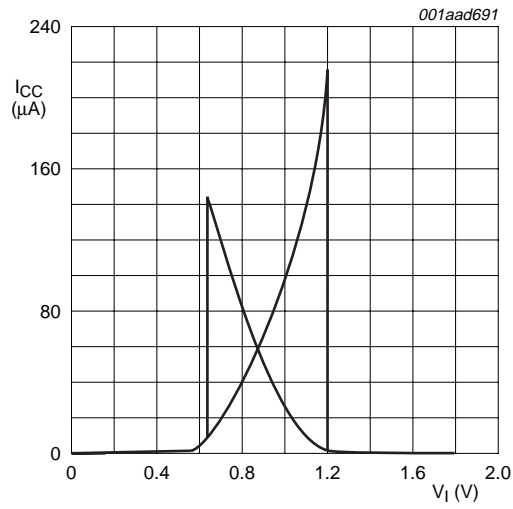

Fig 8. Typical transfer characteristics; $V_{CC(A)} = 1.8$ V

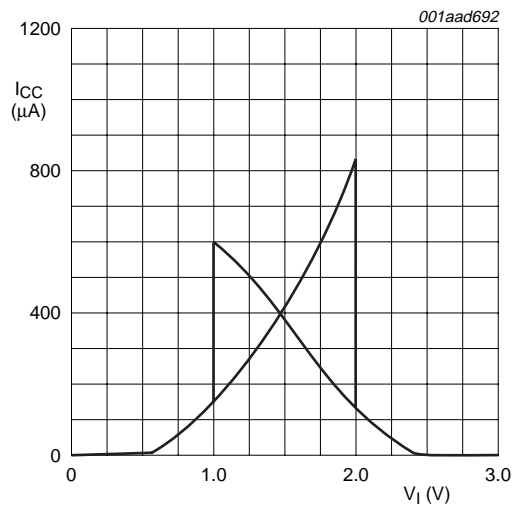

Fig 9. Typical transfer characteristics; $V_{CC(A)} = 3.0$ V

15. Package outline

XSON8: plastic extremely thin small outline package; no leads; 8 terminals; body 1 x 1.95 x 0.5 mm

SOT833-1

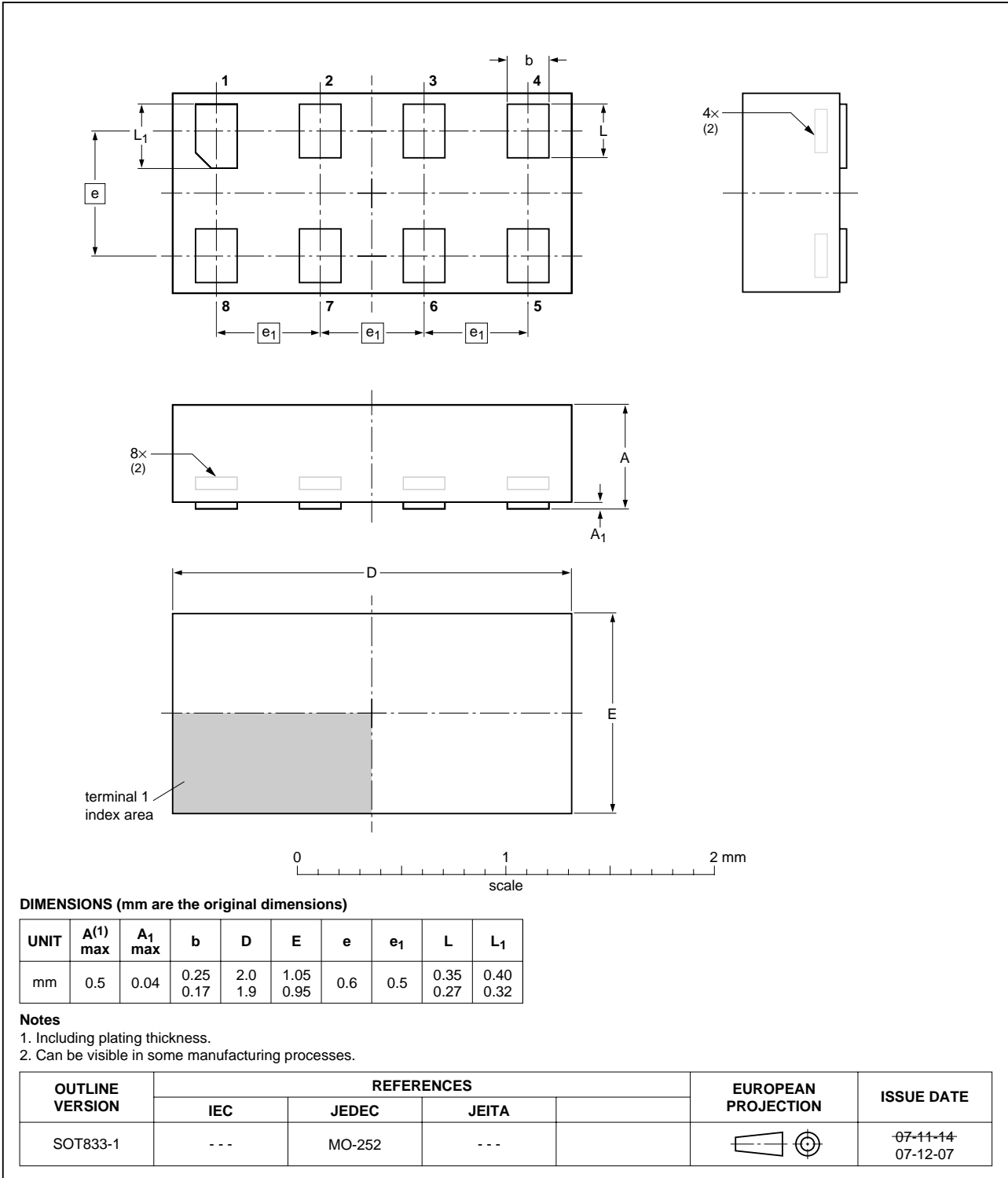

Fig 10. Package outline SOT833-1 (XSON8)

16. Abbreviations

Table 12. Abbreviations

Acronym	Description
CDM	Charged Device Model
CMOS	Complementary Metal-Oxide Semiconductor
DUT	Device Under Test
ESD	ElectroStatic Discharge
HBM	Human Body Model
MM	Machine Model
TTL	Transistor-Transistor Logic

17. Revision history

Table 13. Revision history

Document ID	Release date	Data sheet status	Change notice	Supersedes
74AUP1T1326_1	20090120	Product data sheet	-	-

18. Legal information

18.1 Data sheet status

Document status ^{[1][2]}	Product status ^[3]	Definition
Objective [short] data sheet	Development	This document contains data from the objective specification for product development.
Preliminary [short] data sheet	Qualification	This document contains data from the preliminary specification.
Product [short] data sheet	Production	This document contains the product specification.

[1] Please consult the most recently issued document before initiating or completing a design.

[2] The term 'short data sheet' is explained in section "Definitions".

[3] The product status of device(s) described in this document may have changed since this document was published and may differ in case of multiple devices. The latest product status information is available on the Internet at URL <http://www.nxp.com>.

18.2 Definitions

Draft — The document is a draft version only. The content is still under internal review and subject to formal approval, which may result in modifications or additions. NXP Semiconductors does not give any representations or warranties as to the accuracy or completeness of information included herein and shall have no liability for the consequences of use of such information.

Short data sheet — A short data sheet is an extract from a full data sheet with the same product type number(s) and title. A short data sheet is intended for quick reference only and should not be relied upon to contain detailed and full information. For detailed and full information see the relevant full data sheet, which is available on request via the local NXP Semiconductors sales office. In case of any inconsistency or conflict with the short data sheet, the full data sheet shall prevail.

18.3 Disclaimers

General — Information in this document is believed to be accurate and reliable. However, NXP Semiconductors does not give any representations or warranties, expressed or implied, as to the accuracy or completeness of such information and shall have no liability for the consequences of use of such information.

Right to make changes — NXP Semiconductors reserves the right to make changes to information published in this document, including without limitation specifications and product descriptions, at any time and without notice. This document supersedes and replaces all information supplied prior to the publication hereof.

Suitability for use — NXP Semiconductors products are not designed, authorized or warranted to be suitable for use in medical, military, aircraft, space or life support equipment, nor in applications where failure or

malfunction of an NXP Semiconductors product can reasonably be expected to result in personal injury, death or severe property or environmental damage. NXP Semiconductors accepts no liability for inclusion and/or use of NXP Semiconductors products in such equipment or applications and therefore such inclusion and/or use is at the customer's own risk.

Applications — Applications that are described herein for any of these products are for illustrative purposes only. NXP Semiconductors makes no representation or warranty that such applications will be suitable for the specified use without further testing or modification.

Limiting values — Stress above one or more limiting values (as defined in the Absolute Maximum Ratings System of IEC 60134) may cause permanent damage to the device. Limiting values are stress ratings only and operation of the device at these or any other conditions above those given in the Characteristics sections of this document is not implied. Exposure to limiting values for extended periods may affect device reliability.

Terms and conditions of sale — NXP Semiconductors products are sold subject to the general terms and conditions of commercial sale, as published at <http://www.nxp.com/profile/terms>, including those pertaining to warranty, intellectual property rights infringement and limitation of liability, unless explicitly otherwise agreed to in writing by NXP Semiconductors. In case of any inconsistency or conflict between information in this document and such terms and conditions, the latter will prevail.

No offer to sell or license — Nothing in this document may be interpreted or construed as an offer to sell products that is open for acceptance or the grant, conveyance or implication of any license under any copyrights, patents or other industrial or intellectual property rights.

18.4 Trademarks

Notice: All referenced brands, product names, service names and trademarks are the property of their respective owners.

19. Contact information

For more information, please visit: <http://www.nxp.com>

For sales office addresses, please send an email to: salesaddresses@nxp.com

20. Contents

1	General description	1
2	Features	1
3	Ordering information	2
4	Marking	2
5	Functional diagram	2
6	Pinning information	3
6.1	Pinning	3
6.2	Pin description	3
7	Functional description	3
8	Limiting values	4
9	Recommended operating conditions	4
10	Static characteristics	5
11	Dynamic characteristics	7
12	Waveforms	16
13	Transfer characteristics	19
14	Waveforms transfer characteristics	19
15	Package outline	21
16	Abbreviations	22
17	Revision history	22
18	Legal information	23
18.1	Data sheet status	23
18.2	Definitions	23
18.3	Disclaimers	23
18.4	Trademarks	23
19	Contact information	23
20	Contents	24

Please be aware that important notices concerning this document and the product(s) described herein, have been included in section 'Legal information'.



© NXP B.V. 2009.

All rights reserved.

For more information, please visit: <http://www.nxp.com>

For sales office addresses, please send an email to: salesaddresses@nxp.com

Date of release: 20 January 2009

Document identifier: 74AUP1T1326_1