

Micro Power Module Dual-voltage DC/DC Regulator

Features

- Wide Input Voltage Range: **3V to 18V DC**
- Outputs up to **1500mA**
- Dual Output Voltages: **5V and 3.3V**
- Independent Shutdowns (master and 3.3V)
- $\pm 3\%$ Overall Output Voltage Tolerance
- Reverse Battery Protection
- Over Current Protection
- Thermal Limiting
- Utilizes Low Profile SMT Components
- Low Shutdown Current: $< 20\mu\text{A}$

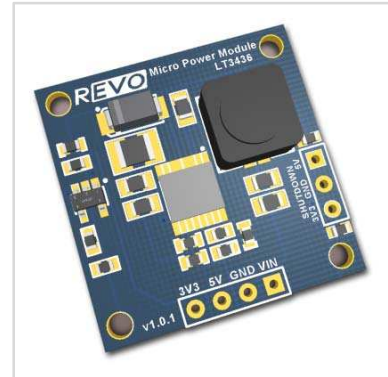

Applications

- USB powered devices
- Fail-safe systems running off batteries
- Prototypes using a variety of power sources
- Battery operated devices including single cell Lithium Polymer applications
- Systems with unknown / wide input voltage requirements
- Breadboard Power Supply

Typical Application

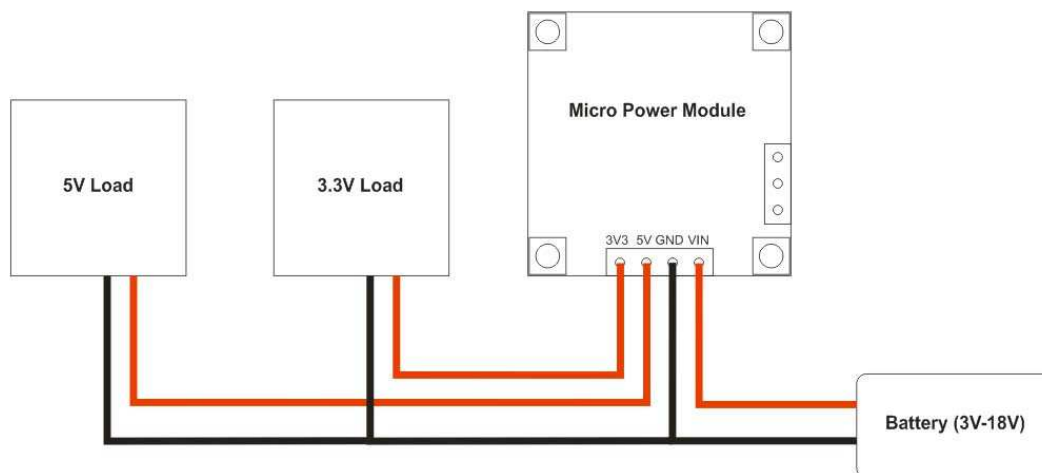

Micro Power Module

Description

The Micro Power Module DC-DC regulator is a drop in solution designed to simplify power regulation for projects where the input voltage differs widely. The module provides a low-noise regulated 5V and 3.3V power supply from a wide range of DC sources including single cell lithium polymer batteries.

The onboard regulator provides both a buck and boost (step up/down) capabilities, allowing for a wider selection of DC input sources. The input voltage can be as low as 3V and as high as 18V while still providing a clean 5V and 3.3V supply. The shutdown pins can be used to turn off the 3.3V channel, or shutdown the whole module.

The module is capable of supplying up to 1A of total output by itself. The module can output up to 1.5A with a attention to thermal considerations, such as attaching a heat-sink. Note that the 3.3V channel outputs 400mA and is generated by an onboard LDO.

This module is meant to ease power regulation in projects that utilize a variety of DC power sources or when the DC source may drop below cut-off thresholds for LDOs. For example this board is useful in applications that utilize single cell lithium polymer batteries that still require 5 volts.

Design Considerations

Typical batteries (Alkaline / Ni-Cd) have an operating voltage range of 1.5V down to 0.75V per cell. That means in typical 4 cell packs, LDO (linear drop out) regulators requiring a voltage drop will source approximately half of the available capacity before the voltage drops below the operating threshold. Lithium batteries have a flatter discharge curve but operate at entirely different cell voltages making single cell operation difficult. To simplify the usage, the Micro Power Module was designed with a SEPIC topology. The SEPIC design allows for the input voltage to be less than, greater than, or equal to the output voltage giving greater flexibility in power source selection.

Part Information

Maximum Ratings (Operating at or near these limits may reduce the operating life and reliability of this device.)

Absolute Maximum Input Voltage:	20V (25V transient)
Operating Temperature Range:	0° C to 100° C
Storage Temperature Range:	-40° C to 125° C
Absolute Maximum Output Current:	1.8A (2A transient ¹)
Board Dimensions:	1" x 1"

¹ Warning: When operating at high power loads, current spikes may push the inductor into saturation.

Micro Power Module

Performance Limitations and Capabilities :

These tests were performed with a stock Micro Power Module. No heat sinks were used in these tests. Results may vary.

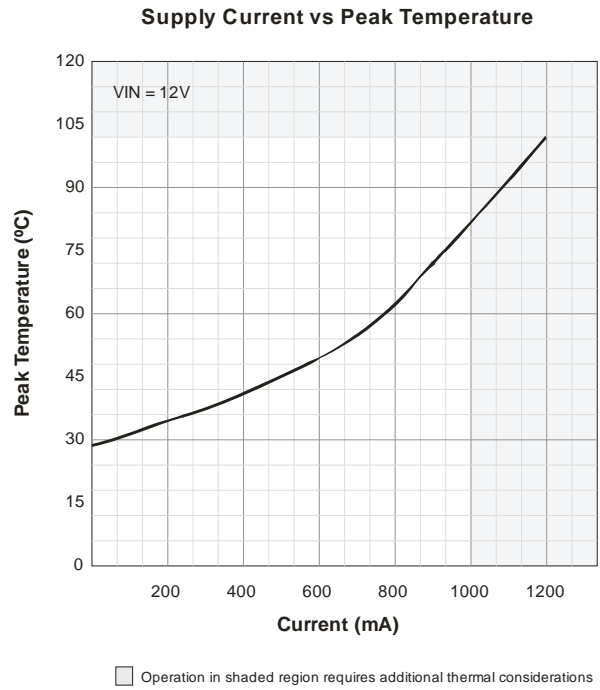
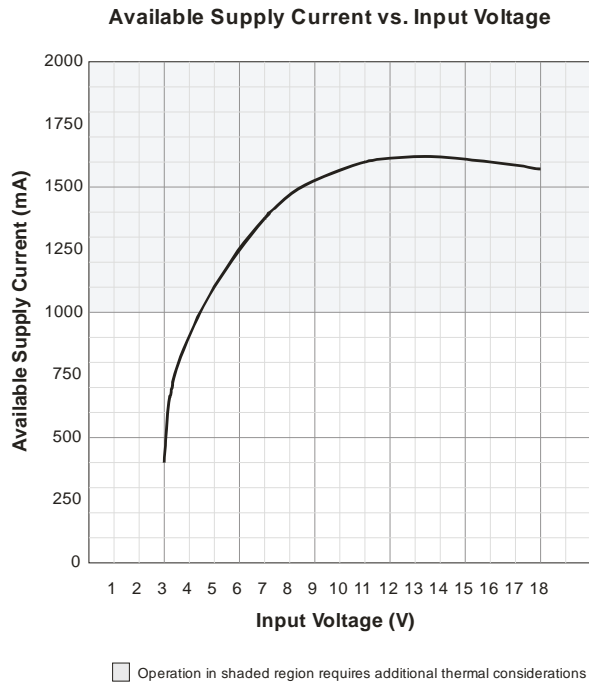

Output Noise :

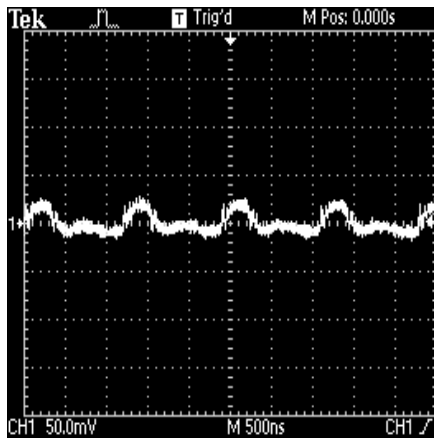

VIN = 3.7v IOUT = 800mA P-P = 50mV

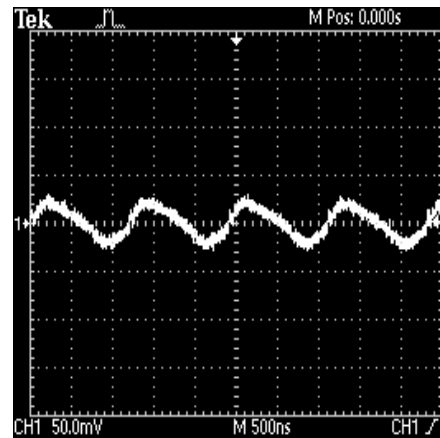

VIN = 12v IOUT = 1000mA P-P = 80mV

Application & Usage Information

Usage

To use the regulator, connect any appropriate battery or DC source to VIN and the 5V and 3.3V lines will rise to their respective output voltages. GND is a common ground shared between the input and output.

Output Voltages

The primary regulator generates the 5V output from VIN with as little as 3V by utilizing a SEPIC topology. This output is fed into the secondary regulator (LDO) to provide up to 400mA of output at 3.3V.

Current Supply

The regulator's current supply depends on input voltage, supply current, and thermal conditions. A 1A output current requires a minimum input voltage of 5V. See the Available Supply Current vs. Input Voltage graph above.

High currents require higher input voltages. If too much power is drawn through the regulator, the inductor will saturate and overheat. Thermal controls will limit the power output to protect the device. It is advisable to attach a heat sink if the device is running hot, placed in enclosed spaces, or is attached to a large load.

Shutdown

Both the primary 5V output and the 3.3V output can be shutdown independently. To shutdown either the primary or secondary regulators, connect the shutdown pin to ground.

Because the power system is cascaded, shutting down the primary regulator disables the 3.3V regulator. The 3.3V regulator can be independently operated without the primary regulator if sufficient power is fed into the 5V line.

Caution: HOT!

Under load, the inductor can become very hot. Handle with caution! Exceeding the operating temperature will limit output power as well as the reliability of this device and continuous operation at these maximums will limit the lifetime of this device. When the thermal threshold is reached, the power output of the device will decrease. To avoid this issue under heavy loads, reduce thermal stress by attaching a heat sink. This will help to regulate the temperature of the device and maintain higher power outputs.

Micro Power Module

Package Description

Board Dimensions

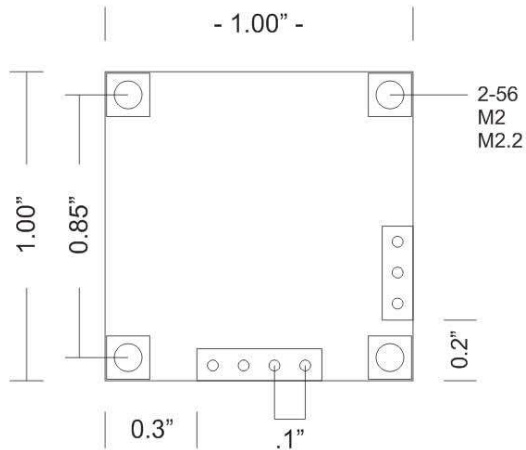

Board Pinout

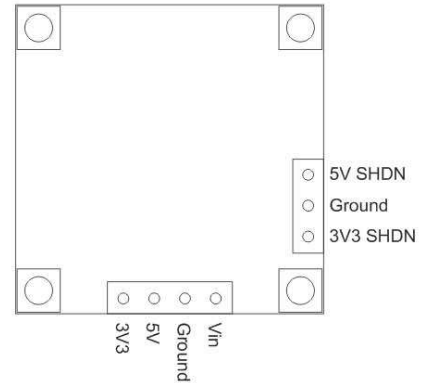

Actual Size

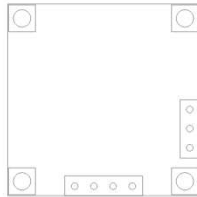

REVO, REVO, and Revolution Robotics are registered trademark of Revolution Robotics, Inc. All other trademarks are the property of their respective owners.

Information furnished by Revolution Robotics Incorporated is believed to be accurate and reliable. However, no responsibility is assumed for its use. Revolution Robotics Incorporated makes no representation that the interconnection of its circuits as described herein will not infringe on existing patent rights.