

# GETTING STARTED

Welcome

The ecobee Remote Sensor Module (RSM)

enables you to connect up to 4 remote sensors to your ecobee Smart or ecobee EMS system.

The ecobee Smart or ecobee EMS system must be using software version 2.1 or later to support the RSM. If you are not running this version, please contact ecobee support to have your thermostat upgraded.

To verify the version you are running:



From the Home

screen, press More.



Press Settings and select About from the Menu.

## Specifications

Operating Temp: -40 to 160F (-40C to 70C)  
 Operating Humidity: 5-95% R.H  
 non-condensing

### Sensor Compatibility

The EB-RSM is pre-configured to support these sensors:

<b>Honeywell</b>	C7189U indoor sensor,
<b>Tekmar</b>	C7089U outdoor sensor, D076 indoor sensor, D079 slab sensor, D084 flush mount sensor
<b>Johnson Controls</b>	HT-6703 humidity sensor, CD-W00 CO2 sensor*

**\*note: The ecobee Smart Thermostat does not support CO2 sensors.**

Other temperature sensors can be supported by just entering the B value or the resistance reported by the sensor at 70°F (21°C) during the configuration process.

## Remote Sensor Module User Manual



ecobee's sole responsibility shall be to repair or replace the Product within the terms stated above. ECOBEE SHALL NOT BE LIABLE FOR ANY LOSS OR DAMAGE OF ANY KIND, INCLUDING ANY SPECIAL, INCIDENTAL OR CONSEQUENTIAL DAMAGES RESULTING, DIRECTLY OR INDIRECTLY, FROM ANY BREACH OF ANY WARRANTY, EXPRESS OR IMPLIED, OR ANY OTHER FAILURE OF THIS PRODUCT. Some US states and Canadian provinces do not allow the exclusion or limitation of incidental or consequential damages, so the above limitation or exclusion may not apply to you. ecobee's responsibility for malfunctions and defects in materials and workmanship is limited to repair and replacement as set forth in this warranty statement. All express and implied warranties for the product, including but not limited to any implied warranties and conditions of merchantability and fitness for a particular purpose, are limited to the three-year duration of this limited warranty. No warranties, whether express or implied, will apply after the limited warranty period has expired. Some US states and Canadian provinces do not allow limitations on how long an implied warranty lasts, so this limitation may not apply. ecobee neither assumes responsibility for nor authorizes any other person purporting to act on its behalf to modify or to change this warranty, nor to assume for it any other warranty or liability concerning this product. This warranty gives you specific rights, and you may also have other rights which vary from jurisdiction to jurisdiction. If you have any questions regarding this warranty, please write ecobee Customer Service, 477 Richmond Street West, #210, Toronto, Ontario M5V 3E7, Canada or contact customer service at 1-877-9-ecobee (32-6233).

## Sensor Inputs

The inputs of the Remote Sensor Module can be configured to support different types of technologies. Refer to the following table for the various options.

Sensor Position	R1	R2	R3	R4
Dry Contact	Yes	Yes	Yes	Yes
Temperature	Yes	Yes	Yes	Yes
10KΩ NTC	Yes	Yes	Yes	Yes
Resistive	Yes	Yes	Yes	Yes
Humidity or CO2	No	No	Yes	Yes
Humidity or CO2	No	No	Yes	Yes
Humidity or CO2	No	No	Yes	Yes

- was operated/stored in abnormal use or maintenance conditions;
- is repaired, modified or altered, unless ecobee expressly authorizes such repair, modification or alteration in writing;
- was subject to abuse, neglect, electrical fault, improper handling, accident or acts of nature;
- was not installed by a licensed Heating Ventilating and Air Conditioning (HVAC) contractor; or
- was installed improperly.

If the product is defective, contact the supplier from whom the product was purchased to obtain an equivalent replacement product, provided the supplier determines that the returned Product is defective and the Customer is otherwise eligible to receive a replacement product;

This warranty does not cover removal or reinstallation costs and shall not apply if the damages were found to be caused by something other than defects in materials or workmanship, including without limitation, if the product:

ecobee warrants that for a period of three (3) years from the date of purchase by the consumer ("Customer"), the ecobee Remote Sensor Module (the "Product") shall be free of defects in materials and workmanship under normal use and service. During the warranty period, ecobee shall, at its option, repair or replace any defective products, at no charge. Any replacement and/or repaired device are warranted for the remainder of the original warranty or ninety (90) days, whichever is longer.

## Status LED

The Remote Sensor Module has two LEDs to display the status of the system. If you've wired the system correctly, only the Power LED should be on.

**Power**  
LED ON Green indicates the module has power and is operational.

**Communication**  
LED ON Red indicates the module is **not** communicating to the thermostat. Blinking red indicates the supply voltage is too low

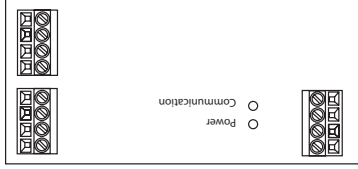

LED arrangement



©2010 ecobee  
 477 Richmond Street West | Suite 210  
 Toronto | Ontario | M5V 3E7 | Canada  
 toll free 1.877.932.6233  
 www.ecobee.com

IM-RSM-R2

## Installation

The Remote Sensor Module is mounted within the Equipment Interface enclosure.

To begin, remove the front cover of the Equipment Interface. If necessary, insert a flat-head screwdriver into one of the slots as shown below, and gently twist the screwdriver. Refer to *fig. 1* for positioning.

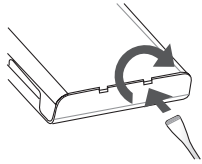

Insert a screwdriver into one of the two slots and twist gently

To access the wiring channels for the Sensor Module simply remove the screws to release the plastic covers affixed to the front panel of the Equipment Interface. Refer to *fig. 2*.

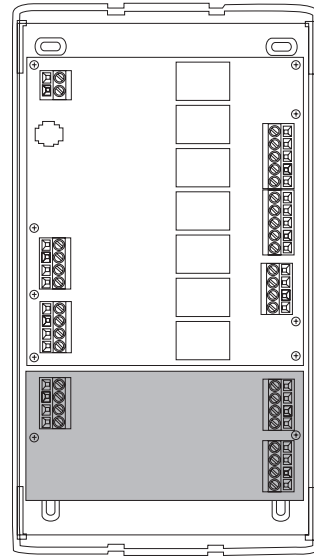

fig1 Indicates Sensor Module mounting location

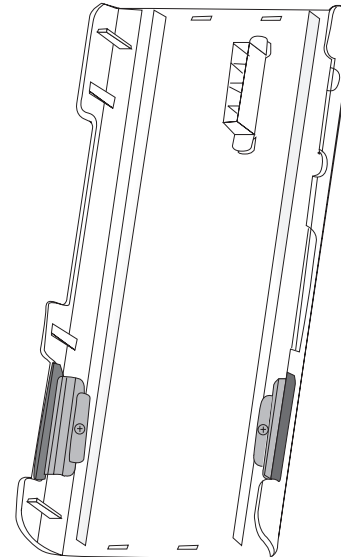

fig2 Indicates the plastic covers over wiring channel

## Wiring Diagram

### Wiring Specifications

Refer to this table to determine maximum wire lengths allowed:

#### Equipment Interface to Sensor Module

18 AWG

1000ft/380m

#### Sensor Module to Sensors

18 AWG

250ft/39m

### Jumper Settings

For proper operation, all 4 switches on SW1 should be in the OFF or down position as indicated in the drawing to the right.

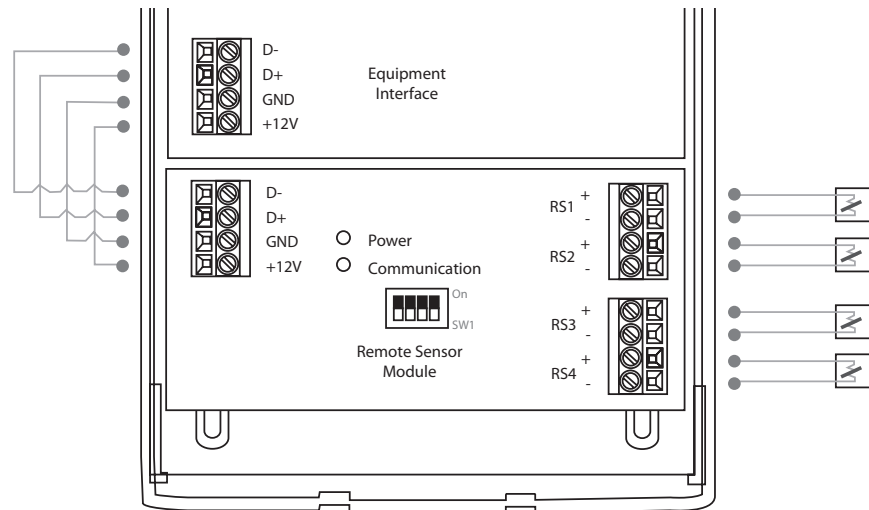

Wiring the RSM to the Equipment Interface

## Programming

All programming of the RSM is done through the touch screen interface of the ecobee Smart or ecobee EMS thermostats.

The sensors can be configured through the *sensors* menu item in the Installation Settings.

To configure the sensor settings:



From the Home screen, press More.



Press Settings and select Installation Settings

Refer to the respective installation manual for more details.

## Monitoring

Once the sensors have been configured they can be monitored from the *sensors* icon in the *More* screen.

To monitor sensors:



From the Home screen, press More.



Select the Sensor icon.

If a sensor is configured as a control sensor, you will be able to select which sensors will be used as the set temperature. If more than one is chosen the Thermostat will take the average of those sensors. The same logic applies for indoor humidity sensors.