

# DIG200

## Digital Ident Generator

INSERTERS

SWITCHES

CONVERSION

KEYERS

MIXERS

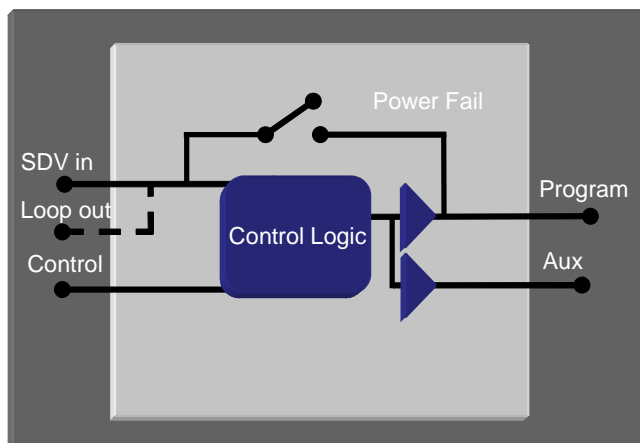

Series 200 eurocard

Stores 6 idents or logos

SDI logo grab

Internal down stream keyer

Internal text generator



The DIG200 is an integrated logo generator and down stream keyer on a single Series 200 eurocard. It is designed to insert logos or station idents onto the outgoing picture in serial digital video (SDV) installations. The card can store 6 'idents' which are images that can be 256 x 256 pixels for 'bugs' or 720 x 80 lines for text idents. A simple text generator with a fixed font provides a 7th ident of up to 20 characters; several text strings can be stored and recalled. Each ident is stored as foreground and matte, it is linear keyed onto the program input so it can be semi-transparent and faded in and out. A CPU card (IG-CPU) is required in each frame to load the images, set their position and enter text, this also provides the RS232/422 ports for automation and remote control operation.

### Programming

Idents can be 'grabbed' (programmed) from the SDV input of the CPU card, this allows direct transfer from graphics systems. Foreground and matte (key) are grabbed separately. The SDV program passes through to the main output of the ident card while programming is in progress (active bypass). Each image can be positioned anywhere on the screen and may be moved around after being stored on the ident card. Once programmed the ident card may be used without the CPU card in the frame.

### Keying

Keying is done internally with a linear keyer. Transition time can be set for timed fades of the logo. Fades can be triggered by GPIs or via automation or remote control. Embedded audio and VBI data present in the incoming SDV signal are passed transparently.

# MicroVideo

Copley Hill Farm  
Babraham  
Cambridge  
England, CB22 3GN  
t: +44 (0) 1223 834119  
f: +44 (0) 1223 834471  
w: [www.microvideo.co.uk](http://www.microvideo.co.uk)

# DIG200

## Technical Information

INSERTERS

SWITCHES

CONVERSION

KEYERS

MIXERS

- Inputs (DIG200):** 1 x Serial Digital Video (270Mb/s) to EBU Tech. 3267-E, (SMPTE 259M).
- Outputs (DIG200):** 2 x Serial Digital Video (270Mb/s) to EBU Tech. 3267-E, (SMPTE 259M).  
'Program' and 'Auxiliary'.  
SDV input connects directly to 'PGM' output upon loss of power, 'Aux' is a copy of the program output but is not valid if no power is applied.
- Inputs (IG-CPU):** 1 x Serial Digital Video (270Mb/s) to EBU Tech. 3267-E, (SMPTE 259M).
- Outputs (IG-CPU):** 1 x Serial Digital Video (270Mb/s) to EBU Tech. 3267-E, (SMPTE 259M).
- Control:** GPI inputs to DIG200 to fade logos up/down.  
RS232/RS422 is also provided to IG-CPU for remote control panel or automation interface.
- Physical:** Single eurocard.
- Power usage:** 5.5W
- Ordering:**
- |         |  |
|---------|--|
| DIG200  | Digital Ident Generator module                           |
| IG-CPU  | CPU card for programming and RS232/422 control           |
| FR1U-20 | 1U rack mounting frame for series 200 cards (dual PSU)   |
| FR3U-10 | 3U rack mounting frame for series 200 cards (single PSU) |
| FR3U-20 | 3U rack mounting frame for series 200 cards (dual PSU)   |
| -CB     | Control Bus wiring for 3U frame                          |
| -FP     | Active front panel control for FR1U frames               |
| REM-DIG | Remote control panel for DIG200 frames                   |

MicroVideo

Copley Hill Farm  
Babraham  
Cambridge  
England, CB22 3GN  
t: +44 (0) 1223 834119  
f: +44 (0) 1223 834471  
w: [www.microvideo.co.uk](http://www.microvideo.co.uk)