

# NPROC-3

SDI Proc Amp with Gamut Corrector

INSERTERS

SWITCHES

CONVERSION

KEYERS

MIXERS

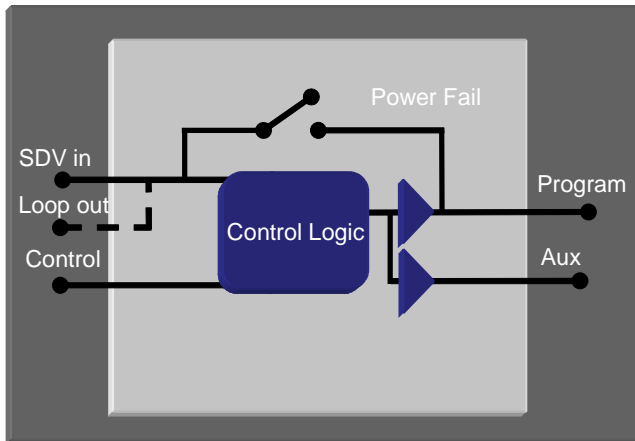

Corrects out of gamut pixels

Full control of digital video levels

Highlights out of gamut pixels

Split screen mode

Front panel or remote control



The NPROC-3 offers a full set of controls for adjustment of video gains and levels. With its additional features and gamut corrector, it provides an ideal digital tool box for dealing with problems on incoming video feeds or preventing them on your outgoing tapes or broadcasts.

## MicroVideo

Copley Hill Farm  
Babraham  
Cambridge  
England, CB22 3GN  
t: +44 (0) 1223 834119  
f: +44 (0) 1223 834471  
w: [www.microvideo.co.uk](http://www.microvideo.co.uk)

# NPROC-3

## Technical Information

INSERTERS

SWITCHES

CONVERSION

KEYERS

MIXERS

<b>Inputs:</b>	Serial Digital Video (270Mb/s) to EBU Tech. 3267-E, (SMPTE 259M).				
<b>Outputs:</b>	3 x Serial Digital Video (270Mb/s) to EBU Tech. 3267-E, (SMPTE 259M). 'Program', 'Auxiliary' and 'Loop'. SDV input connects directly to 'PGM' output upon loss of power, 'Loop' is a copy of the input, 'Aux' is a copy of the program output.				
<b>Functions:</b>	Video Levels	Black level U gain U pedestal	Video gain V gain V pedestal	Chroma gain Y/C delay	Y gain Hue control
	Proc in a Window	The user can define a box on the screen (window). The Proc Amp can be set to only adjust the video levels within this box, making adjustments to a small section of the picture.			
	Cropping	Once the user has defined a window it is possible to blank (set to black) all video outside this window. This can be used, for example, to create letter box effects or increase the line blanking to set it to analogue blanking spec.			
	Y/C Limiting	For clipping of below black and above white spikes. This may be fixed, restricting the luma (Y) to digital values between 16 and 235 and Chroma (C) to -112 to +112, equating to 0 and 100%. Alternatively the user can set their own limits.			
	VBI line blank	Individual lines in the VBI can be blanked. Useful to remove timecode or other VBI data.			
	Memory Select	Stores and recalls up to 16 different setups.			
	Correct illegal	When enabled, a processing engine looks at each pixel and decides if it is out of gamut. If it is, a calculation is made of how much correction should be applied to bring the colour back into the RGB colour space. This means that when the signal is coded to PAL or NTSC it will always remain legal.			
<b>Control:</b>	GPI inputs allow activation of correction, blanking and bypass. RS232/RS422 is also provided for remote control panel or automation interface.				
<b>Physical:</b>	1U rack mounting frame.				
<b>Power usage:</b>	60W				
<b>Ordering:</b>	NPROC-3 -DM	Proc Amp with Gamut Correction for serial digital video Optional dual mains inlet and transformer			

# MicroVideo

Copley Hill Farm  
Babraham  
Cambridge  
England, CB22 3GN  
t: +44 (0) 1223 834119  
f: +44 (0) 1223 834471  
w: [www.microvideo.co.uk](http://www.microvideo.co.uk)