

# NPROC-2

Serial Digital Proc Amp

INSERTERS

SWITCHES

CONVERSION

KEYERS

MIXERS

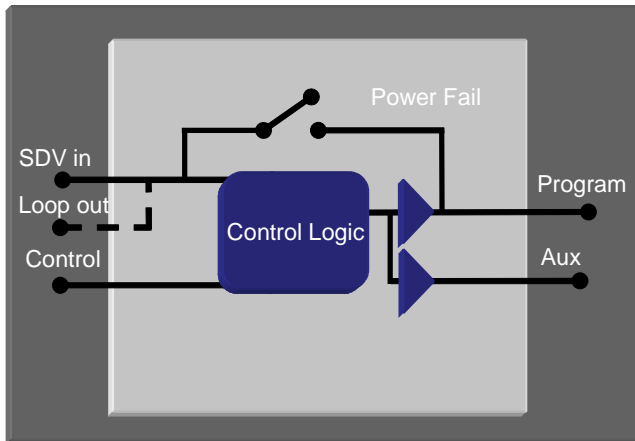

Full control of video levels

Split screen mode

Full control of blanking

Front panel or remote control



The NPROC-2 offers a full set of controls for adjustment of video gains and levels. With its additional features it provides an ideal digital tool box for dealing with problems on incoming video feeds or preventing them on your outgoing tapes or broadcasts.

## MicroVideo

Copley Hill Farm  
Babraham  
Cambridge  
England, CB22 3GN  
t: +44 (0) 1223 834119  
f: +44 (0) 1223 834471  
w: [www.microvideo.co.uk](http://www.microvideo.co.uk)

# NPROC-2

## Technical Information

INSERTERS

SWITCHES

CONVERSION

KEYERS

MIXERS

- Inputs:** Serial Digital Video (270Mb/s) to EBU Tech. 3267-E, (SMPTE 259M).
- Outputs:** 3 x Serial Digital Video (270Mb/s) to EBU Tech. 3267-E, (SMPTE 259M).  
'Program', 'Auxiliary' and 'Loop'.  
SDV input connects directly to 'PGM' output upon loss of power, 'Loop' is a copy of the input, 'Aux' is a copy of the program output.
- Functions:**
- |                  |   |             |             |
|------------------|---|-------------|-------------|
| Video Levels     | Black level   | Video gain  | Chroma gain |
|                  | Y gain  | U gain      | V gain      |
|                  | Y/C delay   | Hue control | U pedestal  |
|                  | V pedestal  |             |             |
| Proc in a Window | The user can define a box on the screen (window). The Proc Amp can be set to only adjust the video levels within this box, making adjustments to a small section of the picture.  |             |             |
| Cropping         | Once the user has defined a window it is possible to blank (set to black) all video outside this window. This can be used, for example, to create letter box effects or increase the line blanking to set it to analogue blanking spec.       |             |             |
| Y/C Limiting     | For clipping of below black and above white spikes. This may be fixed, restricting the luma (Y) to digital values between 16 and 235 and Chroma (C) to -112 to +112, equating to 0 and 100%. Alternatively the user can set their own limits. |             |             |
| VBI line blank   | Individual lines in the VBI can be blanked. Useful to remove timecode or other VBI data.  |             |             |
| Memory Select    | Stores and recalls up to 16 different setups.   |             |             |
- Control:** GPI inputs allow activation of correction, blanking and bypass.  
RS232/RS422 is also provided for remote control panel or automation interface.
- Physical:** 1U rack mounting frame.
- Power usage:** 60W
- Ordering:** NPROC-2 Proc Amp for serial digital video  
-DM Optional dual mains inlet and transformer

# MicroVideo

Copley Hill Farm  
Babraham  
Cambridge  
England, CB22 3GN  
t: +44 (0) 1223 834119  
f: +44 (0) 1223 834471  
w: [www.microvideo.co.uk](http://www.microvideo.co.uk)