

DATA SHEET

74ABT899

9-bit dual latch transceiver with 8-bit
parity generator/checker (3-State)

Product specification
Supersedes data of 1993 Oct 04
IC23 Data Handbook

1998 Jan 16

9-bit dual latch transceiver with 8-bit parity generator/checker (3-State)

74ABT899

FEATURES

- Symmetrical (A and B bus functions are identical)
- Selectable generate parity or "feed-through" parity for A-to-B and B-to-A directions
- Independent transparent latches for A-to-B and B-to-A directions
- Selectable ODD/EVEN parity
- Continuously checks parity of both A bus and B bus latches as \overline{ERRA} and \overline{ERRB}
- Ability to simultaneously generate and check parity
- Can simultaneously read/latch A and B bus data
- Output capability: +64 mA/-32mA
- Latch-up protection exceeds 500mA per Jedec JC40.2 Std 17
- ESD protection exceeds 2000 V per MIL STD 883 Method 3015 and 200 V per Machine Model
- Power up 3-State
- Power-up reset
- Live insertion/extraction permitted

DESCRIPTION

The 74ABT899 is a 9-bit to 9-bit parity transceiver with separate transparent latches for the A bus and B bus. Either bus can generate or check parity. The parity bit can be fed-through with no change or the generated parity can be substituted with the \overline{SEL} input.

Parity error checking of the A and B bus latches is continuously provided with \overline{ERRA} and \overline{ERRB} , even with both buses in 3-State.

The 74ABT899 features independent latch enables for the A and B bus latches, a select pin for ODD/EVEN parity, and separate error signal output pins for checking parity.

FUNCTIONAL DESCRIPTION

The 74ABT899 has three principal modes of operation which are outlined below. All modes apply to both the A-to-B and B-to-A directions.

Transparent latch, Generate parity, Check A and B bus parity:

Bus A (B) communicates to Bus B (A), parity is generated and passed on to the B (A) Bus as BPAR (APAR). If LEA and LEB are High and the Mode Select (\overline{SEL}) is Low, the parity generated from A0-A7 and B0-B7 can be checked and monitored by \overline{ERRA} and \overline{ERRB} . (Fault detection on both input and output buses.)

Transparent latch, Feed-through parity, Check A and B bus parity:

Bus A (B) communicates to Bus B (A) in a feed-through mode if \overline{SEL} is High. Parity is still generated and checked as \overline{ERRA} and \overline{ERRB} and can be used as an interrupt to signal a data/parity bit error to the CPU.

Latched input, Generate/Feed-through parity, Check A (and B) bus parity:

Independent latch enables (LEA and LEB) allow other permutations of:

- Transparent latch / 1 bus latched / both buses latched
- Feed-through parity / generate parity
- Check in bus parity / check out bus parity / check in and out bus parity

QUICK REFERENCE DATA

SYMBOL	PARAMETER	CONDITIONS $T_{amb} = 25^{\circ}\text{C}; \text{GND} = 0\text{V}$	TYPICAL	UNIT
t_{PLH} t_{PHL}	Propagation delay An to Bn or Bn to An	$C_L = 50\text{pF}; V_{CC} = 5\text{V}$	2.9	ns
t_{PLH} t_{PHL}	Propagation delay An to \overline{ERRA}	$C_L = 50\text{pF}; V_{CC} = 5\text{V}$	6.1	ns
C_{IN}	Input capacitance	$V_I = 0\text{V}$ or V_{CC}	4	pF
$C_{I/O}$	Output capacitance	Outputs disabled; $V_O = 0\text{V}$ or V_{CC}	7	pF
I_{CCZ}	Total supply current	Outputs disabled; $V_{CC} = 5.5\text{V}$	50	μA

ORDERING INFORMATION

PACKAGES	TEMPERATURE RANGE	OUTSIDE NORTH AMERICA	NORTH AMERICA	DWG NUMBER
28-Pin Plastic PLCC	-40°C to +85°C	74ABT899 A	74ABT899 A	SOT261-3
28-Pin Plastic SOP	-40°C to +85°C	74ABT899 D	74ABT899 D	SOT136-1
28-Pin Plastic SSOP	-40°C to +85°C	74ABT899 DB	74ABT899 DB	SOT341-1

9-bit dual latch transceiver with 8-bit parity generator/checker (3-State)

74ABT899

PIN CONFIGURATION

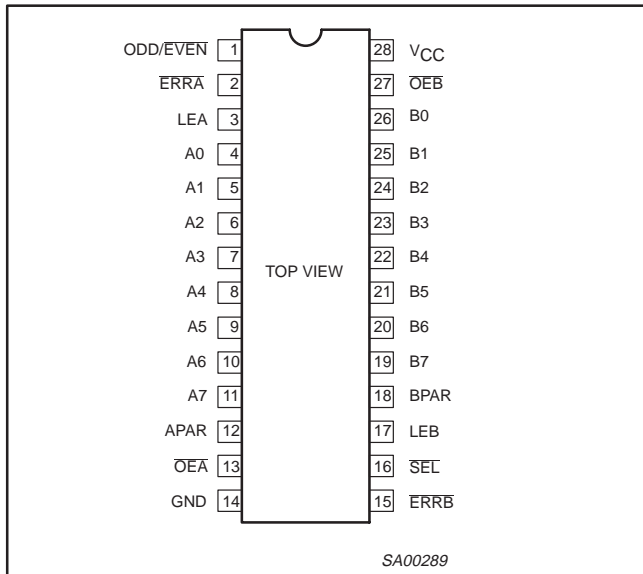

PLCC PIN CONFIGURATION

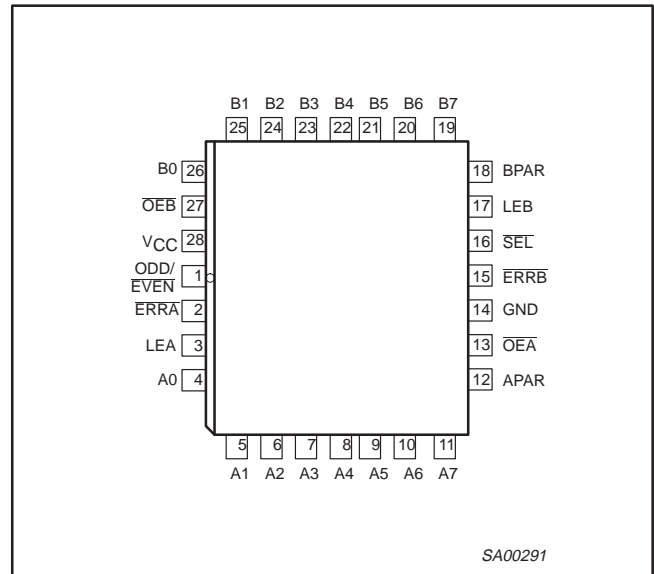

PIN DESCRIPTION

SYMBOL	PIN NUMBER	NAME AND FUNCTION
A0 - A7	4, 5, 6, 7, 8, 9, 10, 11	Latched A bus 3-State inputs/outputs
B0 - B7	19, 20, 21, 22, 23, 24, 25, 26	Latched B bus 3-State inputs/outputs
APAR	12	A bus parity 3-State input
BPAR	18	B bus parity 3-State input
ODD/EVEN	1	Parity select input (Low for EVEN parity)
OEA, OEB	13, 27	Output enable inputs (gate A to B, B to A)
SEL	16	Mode select input (Low for generate)
LEA, LEB	3, 17	Latch enable inputs (transparent High)
ERRA, ERRB	2, 15	Error signal outputs (active-Low)
GND	14	Ground (0V)
V _{CC}	28	Positive supply voltage

LOGIC SYMBOL

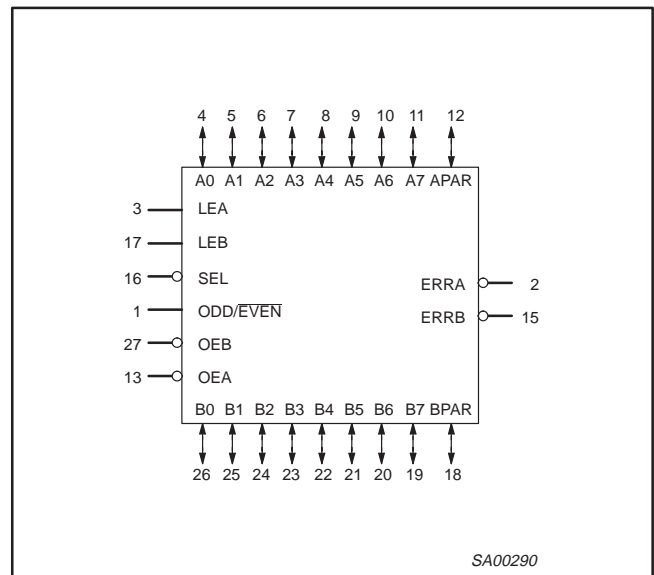

9-bit dual latch transceiver with 8-bit parity generator/checker (3-State)

74ABT899

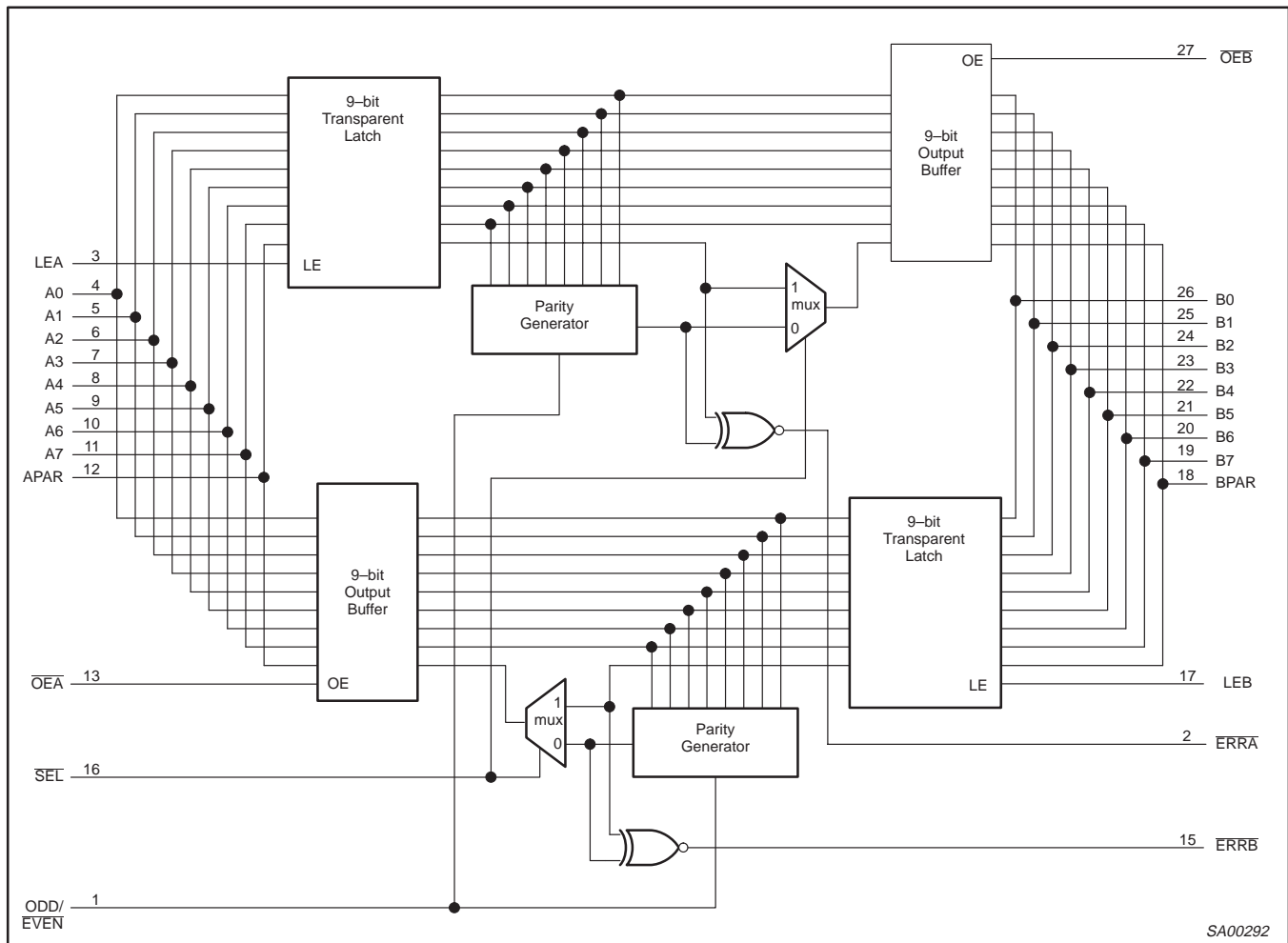

FUNCTION TABLE

INPUTS					OPERATING MODE
OEB	OEA	SEL	LEA	LEB	
H	H	X	X	X	3-State A bus and B bus (input A & B simultaneously)
H	L	L	L	H	B → A, transparent B latch, generate parity from B0 - B7, check B bus parity
H	L	L	H	H	B → A, transparent A & B latch, generate parity from B0 - B7, check A & B bus parity
H	L	L	X	L	B → A, B bus latched, generate parity from latched B0 - B7 data, check B bus parity
H	L	H	X	H	B → A, transparent B latch, parity feed-through, check B bus parity
H	L	H	H	H	B → A, transparent A & B latch, parity feed-through, check A & B bus parity
L	H	L	H	X	A → B, transparent A latch, generate parity from A0 - A7, check A bus parity
L	H	L	H	H	A → B, transparent A & B latch, generate parity from A0 - A7, check A & B bus parity
L	H	L	L	X	A → B, A bus latched, generate parity from latched A0 - A7 data, check A bus parity
L	H	H	H	L	A → B, transparent A latch, parity feed-through, check A bus parity
L	H	H	H	H	A → B, transparent A & B latch, parity feed-through, check A & B bus parity
L	L	X	X	X	Output to A bus and B bus (NOT ALLOWED)

H = High voltage level
 L = Low voltage level
 X = Don't care

9-bit dual latch transceiver with 8-bit parity generator/checker (3-State)

74ABT899

PARITY AND ERROR FUNCTION TABLE

INPUTS				OUTPUTS			PARITY MODES	
SEL	ODD/EVEN	xPAR (A or B)	Σ of High Inputs	xPAR (B or A)	ERRt	ERRr*		
H	H	H	Even Odd	H H	H L	H L	Odd Mode	Feed-through/check parity
H	H	L	Even Odd	L L	L H	L H		
H	L	H	Even Odd	H H	L H	L H		
H	L	L	Even Odd	L L	H L	H L		
L	H	H	Even Odd	H L	H L	H H	Odd Mode	Generate parity
L	H	L	Even Odd	H L	L H	H H		
L	L	H	Even Odd	L H	L H	H H		
L	L	L	Even Odd	L H	H L	H H		

H = High voltage level

L = Low voltage level

t = Transmit—if the data path is from A→B then ERRt is ERRA

r = Receive—if the data path is from A→B then ERRr is ERrB

* Blocked if latch is not transparent

ABSOLUTE MAXIMUM RATINGS^{1, 2}

SYMBOL	PARAMETER	CONDITIONS	RATING	UNIT
V _{CC}	DC supply voltage		-0.5 to +7.0	V
I _{IK}	DC input diode current	V _I < 0	-18	mA
V _I	DC input voltage ³		-1.2 to +7.0	V
I _{OK}	DC output diode current	V _O < 0	-50	mA
V _{OUT}	DC output voltage ³	output in Off or High state	-0.5 to +5.5	V
I _{OUT}	DC output current	output in Low state	128	mA
T _{stg}	Storage temperature range		-65 to 150	°C

NOTES:

- Stresses beyond those listed may cause permanent damage to the device. These are stress ratings only and functional operation of the device at these or any other conditions beyond those indicated under "recommended operating conditions" is not implied. Exposure to absolute-maximum-rated conditions for extended periods may affect device reliability.
- The performance capability of a high-performance integrated circuit in conjunction with its thermal environment can create junction temperatures which are detrimental to reliability. The maximum junction temperature of this integrated circuit should not exceed 150°C.
- The input and output voltage ratings may be exceeded if the input and output current ratings are observed.

9-bit dual latch transceiver with 8-bit parity generator/checker (3-State)

74ABT899

RECOMMENDED OPERATING CONDITIONS

SYMBOL	PARAMETER	LIMITS		UNIT
		Min	Max	
V_{CC}	DC supply voltage	4.5	5.5	V
V_I	Input voltage	0	V_{CC}	V
V_{IH}	High-level input voltage	2.0		V
V_{IL}	Low-level Input voltage		0.8	V
I_{OH}	High-level output current		-32	mA
I_{OL}	Low-level output current		64	mA
$\Delta t/\Delta v$	Input transition rise or fall rate	0	5	ns/V
T_{amb}	Operating free-air temperature range	-40	+85	°C

DC ELECTRICAL CHARACTERISTICS

SYMBOL	PARAMETER	TEST CONDITIONS	LIMITS					UNIT
			$T_{amb} = +25^{\circ}\text{C}$			$T_{amb} = -40^{\circ}\text{C}$ to $+85^{\circ}\text{C}$		
			Min	Typ	Max	Min	Max	
V_{IK}	Input clamp voltage	$V_{CC} = 4.5\text{V}; I_{IK} = -18\text{mA}$		-0.9	-1.2		-1.2	V
V_{OH}	High-level output voltage	$V_{CC} = 4.5\text{V}; I_{OH} = -3\text{mA}; V_I = V_{IL}$ or V_{IH}	2.5	3.5		2.5		V
		$V_{CC} = 5.0\text{V}; I_{OH} = -3\text{mA}; V_I = V_{IL}$ or V_{IH}	3.0	4.0		3.0		V
		$V_{CC} = 4.5\text{V}; I_{OH} = -32\text{mA}; V_I = V_{IL}$ or V_{IH}	2.0	2.6		2.0		V
V_{OL}	Low-level output voltage	$V_{CC} = 4.5\text{V}; I_{OL} = 64\text{mA}; V_I = V_{IL}$ or V_{IH}		0.42	0.55		0.55	V
V_{RST}	Power-up output low voltage ³	$V_{CC} = 5.5\text{V}; I_O = 1\text{mA}; V_I = \text{GND}$ or V_{CC}		0.13	0.55		0.55	V
I_I	Input leakage current	Control pins		± 0.01	± 1.0		± 1.0	μA
		Data pins		± 5	± 100		± 100	μA
I_{OFF}	Power-off leakage current	$V_{CC} = 0.0\text{V}; V_O$ or $V_I \leq 4.5\text{V}$		± 5.0	± 100		± 100	μA
I_{PU}/I_{PD}	Power-up/down 3-State output current ⁴	$V_{CC} = 2.1\text{V}; V_O = 0.5\text{V}; V_I = \text{GND}$ or V_{CC} ; $V_{OE} = \text{Don't care}$		± 5.0	± 50		± 50	μA
$I_{IH} + I_{OZH}$	3-State output High current	$V_{CC} = 5.5\text{V}; V_O = 2.7\text{V}; V_I = V_{IL}$ or V_{IH}		5.0	50		50	μA
$I_{IL} + I_{OZL}$	3-State output Low current	$V_{CC} = 5.5\text{V}; V_O = 0.5\text{V}; V_I = V_{IL}$ or V_{IH}		-5.0	-50		-50	μA
I_{CEX}	Output High leakage current	$V_{CC} = 5.5\text{V}; V_O = 5.5\text{V}; V_I = \text{GND}$ or V_{CC}		5.0	50		50	μA
I_O	Output current ¹	$V_{CC} = 5.5\text{V}; V_O = 2.5\text{V}$	-50	-80	-180	-50	-180	mA
I_{CCH}	Quiescent supply current	$V_{CC} = 5.5\text{V}$; Outputs High, $V_I = \text{GND}$ or V_{CC}		50	250		250	μA
I_{CCL}		$V_{CC} = 5.5\text{V}$; Outputs Low, $V_I = \text{GND}$ or V_{CC}		28	34		34	mA
I_{CCZ}		$V_{CC} = 5.5\text{V}$; Outputs 3-State; $V_I = \text{GND}$ or V_{CC}		50	250		250	μA
ΔI_{CC}	Additional supply current per input pin ²	$V_{CC} = 5.5\text{V}$; one input at 3.4V, other inputs at V_{CC} or GND		0.3	1.5		1.5	mA

NOTES:

- Not more than one output should be tested at a time, and the duration of the test should not exceed one second.
- This is the increase in supply current for each input at 3.4V.
- For valid test results, data must not be loaded into the flip-flops (or latches) after applying the power.
- This parameter is valid for any V_{CC} between 0V and 2.1V, with a transition time of up to 10msec. From $V_{CC} = 2.1\text{V}$ to $V_{CC} = 5\text{V} \pm 10\%$, a transition time of up to 100 μsec is permitted.

9-bit dual latch transceiver with 8-bit parity generator/checker (3-State)

74ABT899

AC CHARACTERISTICS

GND = 0V; $t_R = t_F = 2.5\text{ns}$; $C_L = 50\text{pF}$, $R_L = 500\Omega$

SYMBOL	PARAMETER	WAVEFORM	LIMITS					UNIT
			$T_{amb} = +25^\circ\text{C}$ $V_{CC} = +5.0\text{V}$ $C_L = 50\text{pF}$ $R_L = 500\Omega$			$T_{amb} = -40 \text{ to } +85^\circ\text{C}$ $V_{CC} = +5.0\text{V} \pm 10\%$ $C_L = 50\text{pF}$ $R_L = 500\Omega$		
			Min	Typ	Max	Min	Max	
t_{PLH} t_{PHL}	Propagation delay An to Bn or Bn to An	1	1.0 1.0	3.2 2.7	4.5 4.1	1.0 1.0	4.9 4.6	ns
t_{PLH} t_{PHL}	Propagation delay An to BPAR or Bn to APAR	2	3.0 2.5	6.0 6.4	7.5 7.9	3.0 2.5	9.0 8.8	ns
t_{PLH} t_{PHL}	Propagation delay An to $\overline{\text{ERRA}}$ or Bn to $\overline{\text{ERRB}}$	3	2.8 2.8	6.0 6.7	8.0 8.5	2.8 2.8	9.1 9.3	ns
t_{PLH} t_{PHL}	Propagation delay APAR to BPAR or BPAR to APAR	1	2.0 1.3	4.0 3.2	5.2 4.4	2.0 1.3	5.7 5.0	ns
t_{PLH} t_{PHL}	Propagation delay APAR to $\overline{\text{ERRA}}$ or BPAR to $\overline{\text{ERRB}}$	6	1.5 1.5	4.2 4.0	5.4 5.4	1.5 1.5	6.0 6.1	ns
t_{PLH} t_{PHL}	Propagation delay ODD/EVEN to APAR or BPAR	5	2.6 2.5	5.5 5.3	6.8 6.7	2.6 2.5	8.1 7.8	ns
t_{PLH} t_{PHL}	Propagation delay ODD/EVEN to $\overline{\text{ERRA}}$ or $\overline{\text{ERRB}}$	4	2.3 2.6	5.4 5.7	6.8 7.2	2.3 2.6	7.9 8.4	ns
t_{PLH} t_{PHL}	Propagation delay SEL to APAR or BPAR	8	1.3 1.4	4.1 4.1	5.2 5.3	1.3 1.4	6.0 5.9	ns
t_{PLH} t_{PHL}	Propagation delay SEL to $\overline{\text{ERRA}}$ or $\overline{\text{ERRB}}$	8	3.7 5.1	6.8 8.3	8.3 9.7	3.7 5.1	9.8 11.0	ns
t_{PLH} t_{PHL}	Propagation delay LEA to Bn or LEB to An	9	1.0 1.0	3.2 3.1	4.4 4.5	1.0 1.0	4.9 5.0	ns
t_{PLH} t_{PHL}	Propagation delay LEA to BPAR or LEB to APAR	9	2.0 1.7	6.8 6.3	8.3 7.9	2.0 1.7	9.7 9.0	ns
t_{PLH} t_{PHL}	Propagation delay LEA to $\overline{\text{ERRA}}$ or LEB to $\overline{\text{ERRB}}$	7	2.0 2.0	6.3 7.1	8.3 9.2	2.0 2.0	9.6 10.3	ns
t_{pZH} t_{pZL}	Output enable time $\overline{\text{OE}}\text{A}$ to An, APAR or $\overline{\text{OE}}\text{B}$ to Bn, BPAR	11, 12	1.0 1.0	3.0 3.4	4.3 4.8	1.0 1.0	5.1 5.4	ns
t_{pHZ} t_{pLZ}	Output disable time $\overline{\text{OE}}\text{A}$ to An, APAR or $\overline{\text{OE}}\text{B}$ to Bn, BPAR	11, 12	1.0 0.5	3.4 3.0	4.7 4.2	1.0 0.5	5.5 4.7	ns

AC SETUP REQUIREMENTS

GND = 0V; $t_R = t_F = 2.5\text{ns}$; $C_L = 50\text{pF}$, $R_L = 500\Omega$

SYMBOL	PARAMETER	WAVEFORM	LIMITS					UNIT
			$T_{amb} = +25^\circ\text{C}$ $V_{CC} = +5.0\text{V}$ $C_L = 50\text{pF}$ $R_L = 500\Omega$			$T_{amb} = -40 \text{ to } +85^\circ\text{C}$ $V_{CC} = +5.0\text{V} \pm 10\%$ $C_L = 50\text{pF}$ $R_L = 500\Omega$		
			Min	Typ	Max	Min	Max	
$t_s(\text{H})$ $t_s(\text{L})$	Setup time, High or Low An, APAR to LEA or Bn, BPAR to LEB	10	2.0 1.5	0.4 0.0		2.0 1.5		ns
$t_h(\text{H})$ $t_h(\text{L})$	Hold time, High or Low An, APAR to LEA or Bn, BPAR to LEB	10	1.5 1.0	0.0 -0.2		1.5 1.0		ns
$t_w(\text{H})$	Pulse width, High LEA or LEB	10	3.0	1.9		3.0		ns

9-bit dual latch transceiver with 8-bit parity generator/checker (3-State)

74ABT899

AC WAVEFORMS

$V_M = 1.5V, V_{IN} = GND \text{ to } 3.0V$

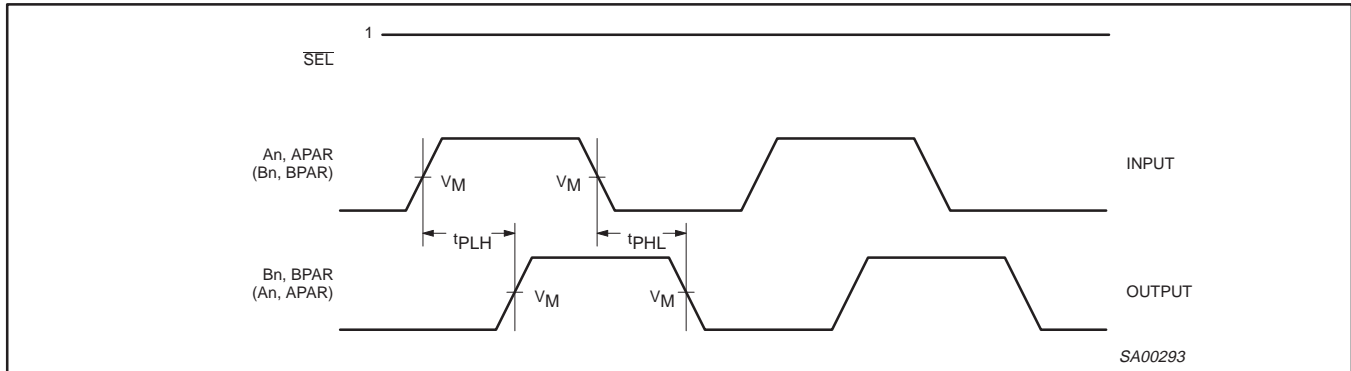

Waveform 1. Propagation Delay, An to Bn, Bn to An, APAR to BPAR, BPAR to APAR

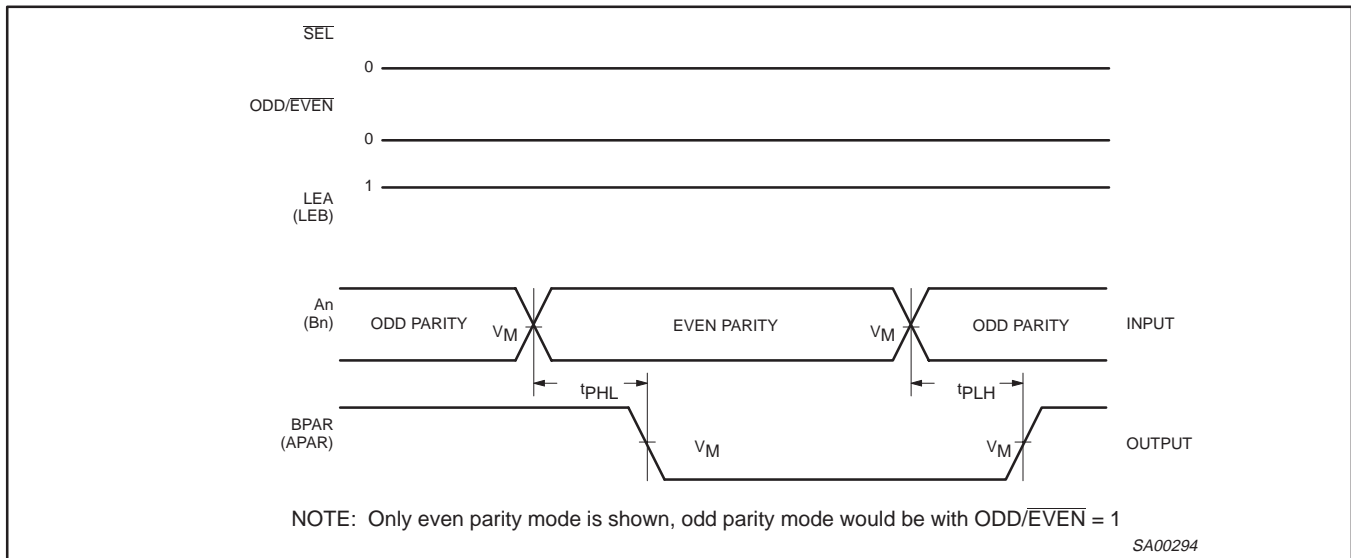

Waveform 2. Propagation Delay, An to BPAR or Bn to APAR

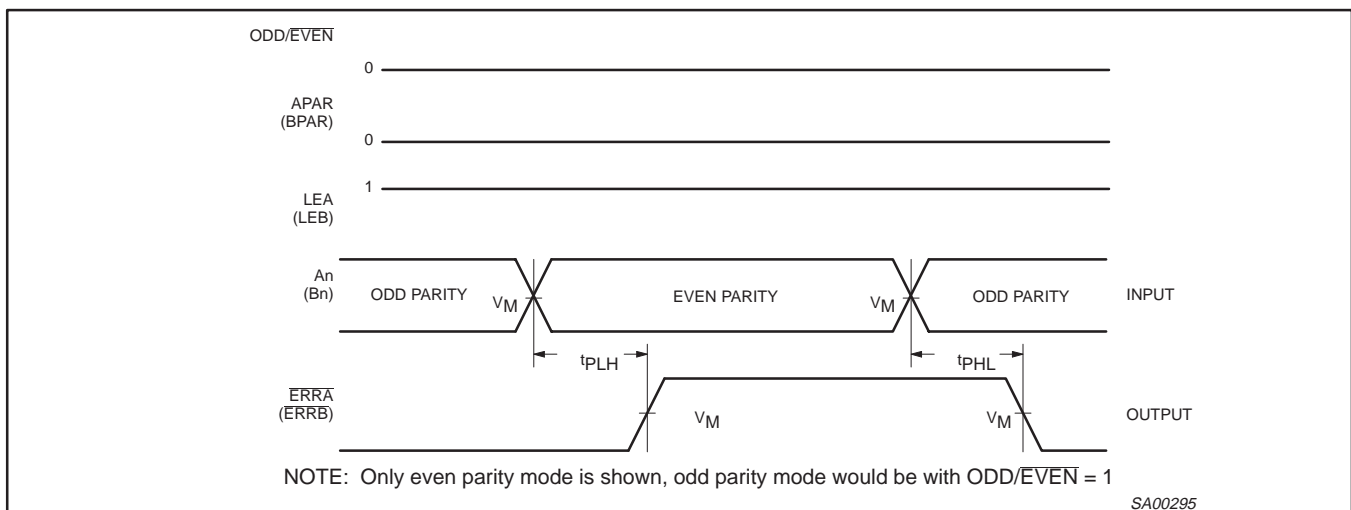

Waveform 3. Propagation Delay, An to \overline{ERRA} or Bn to \overline{ERRB}

9-bit dual latch transceiver with 8-bit parity generator/checker (3-State)

74ABT899

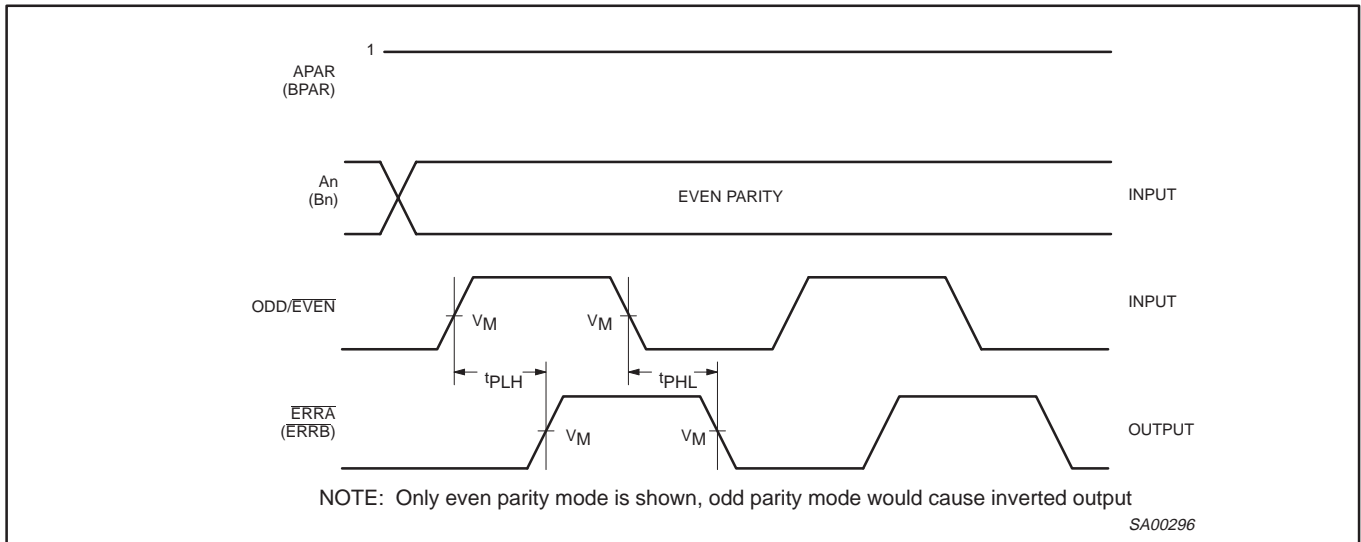

Waveform 4. Propagation Delay, ODD/EVEN to \overline{ERRA} or ODD/EVEN to \overline{ERRB}

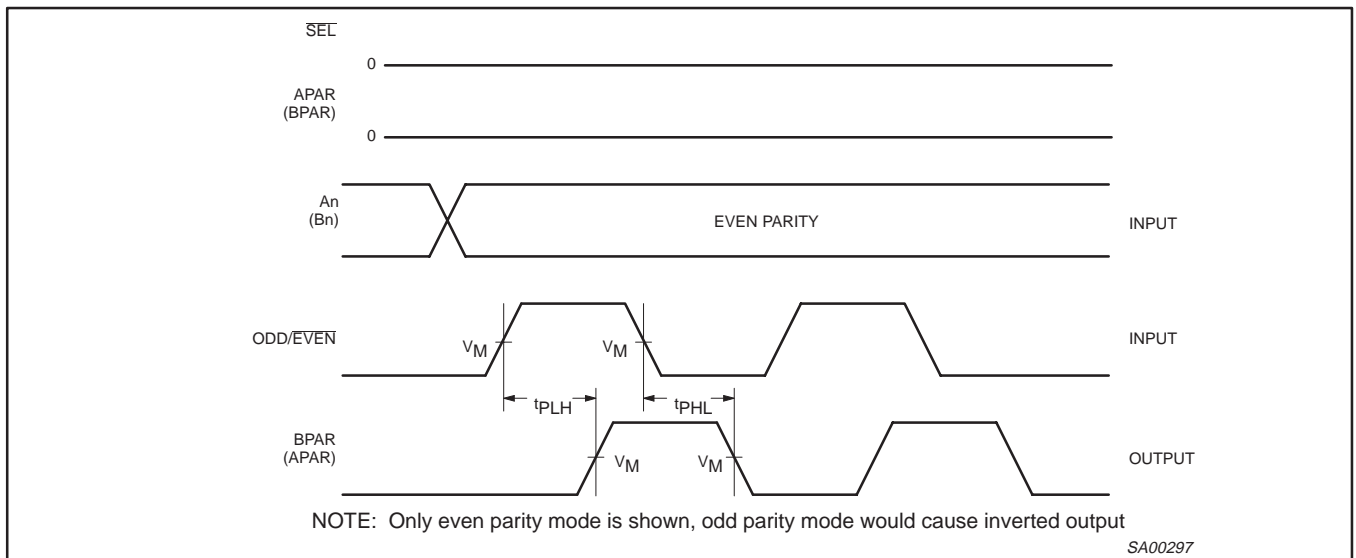

Waveform 5. Propagation Delay, ODD/EVEN to APAR or ODD/EVEN to BPAR

9-bit dual latch transceiver with 8-bit parity generator/checker (3-State)

74ABT899

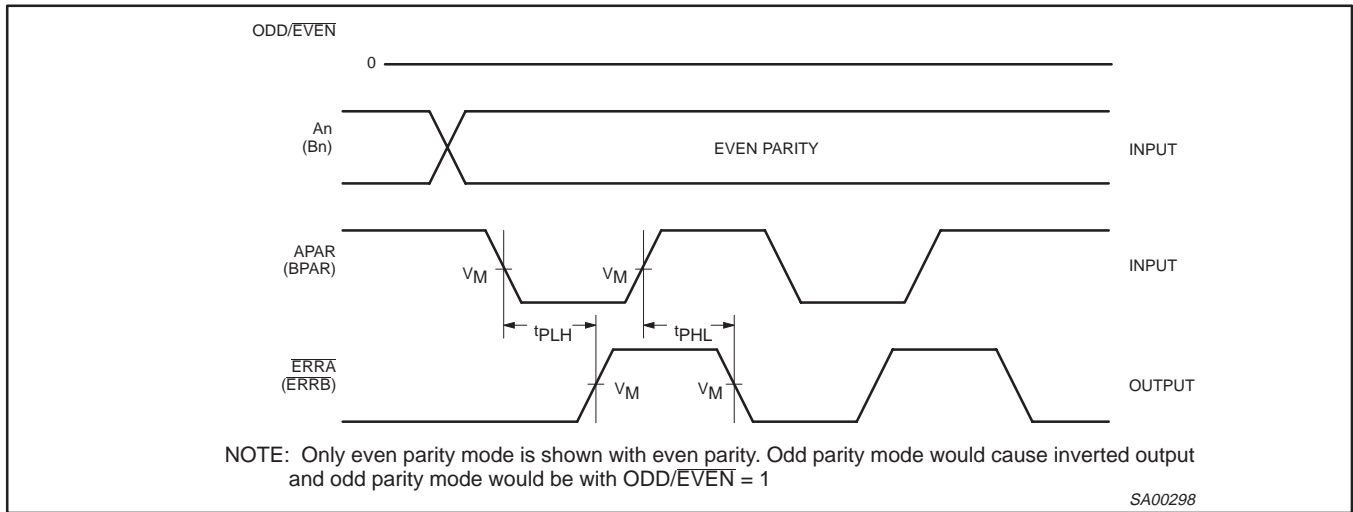

Waveform 6. Propagation Delay, APAR to \overline{ERRA} or BPAR to \overline{ERRB}

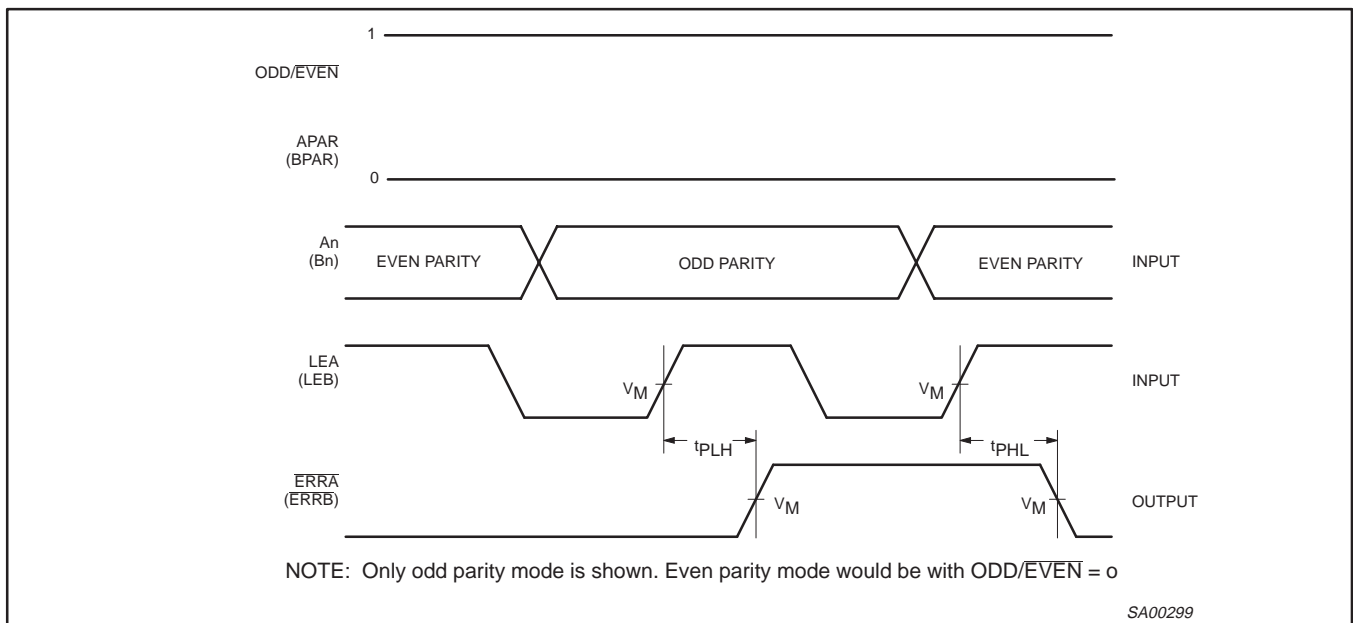

Waveform 7. Propagation Delay, LEA to \overline{ERRA} or LEB to \overline{ERRB}

9-bit dual latch transceiver with 8-bit parity generator/checker (3-State)

74ABT899

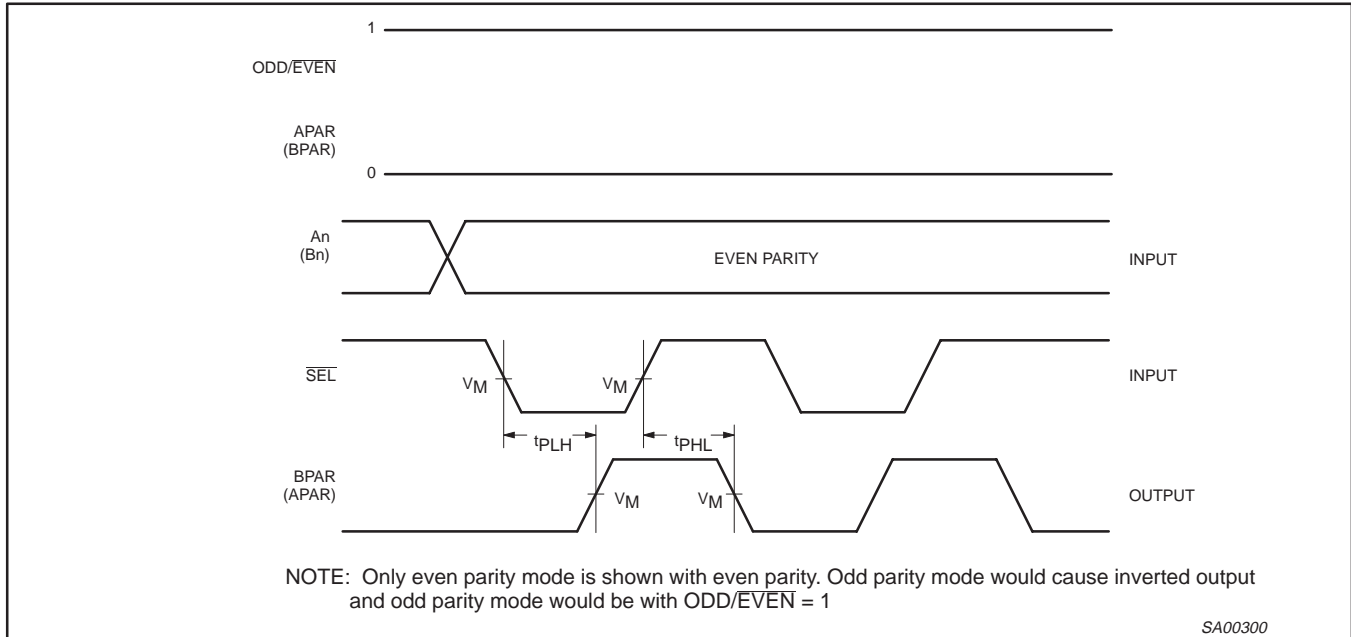

Waveform 8. Propagation Delay, \overline{SEL} to BPAR or \overline{SEL} to APAR

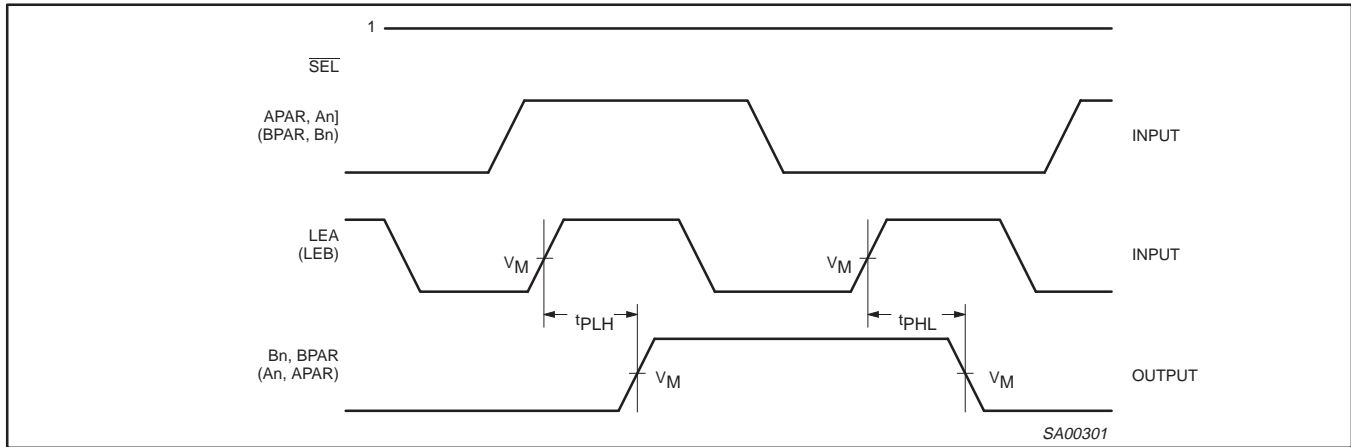

Waveform 9. Propagation Delay, LEA to BPAR or LEB to APAR, LEA to Bn or LEB to An

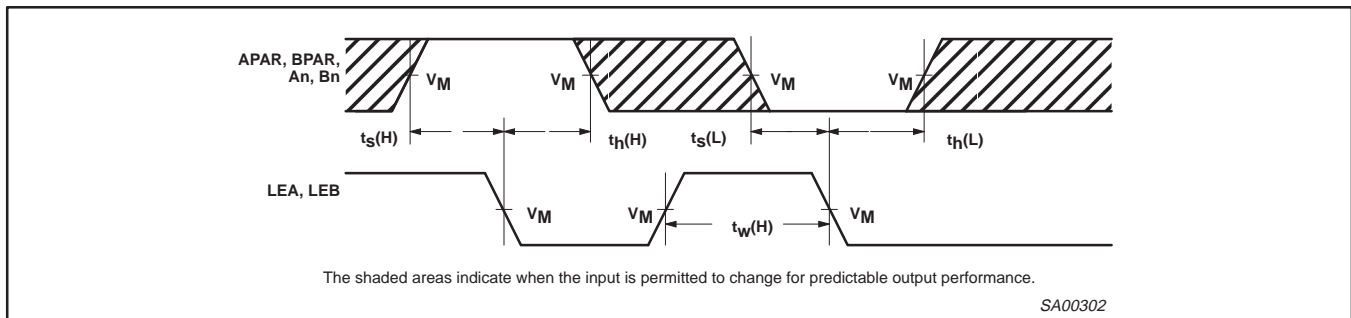

Waveform 10. Data Setup and Hold Times, Pulse Width High

9-bit dual latch transceiver with 8-bit parity generator/checker (3-State)

74ABT899

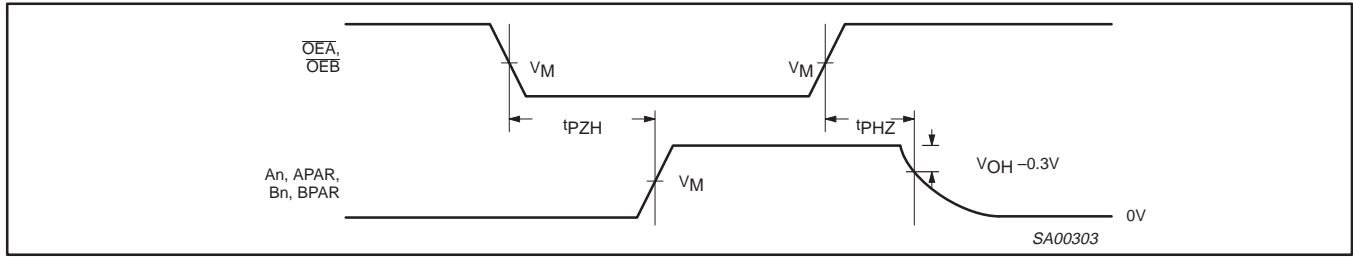

Waveform 11. 3-State Output Enable Time to High Level and Output Disable Time from High Level

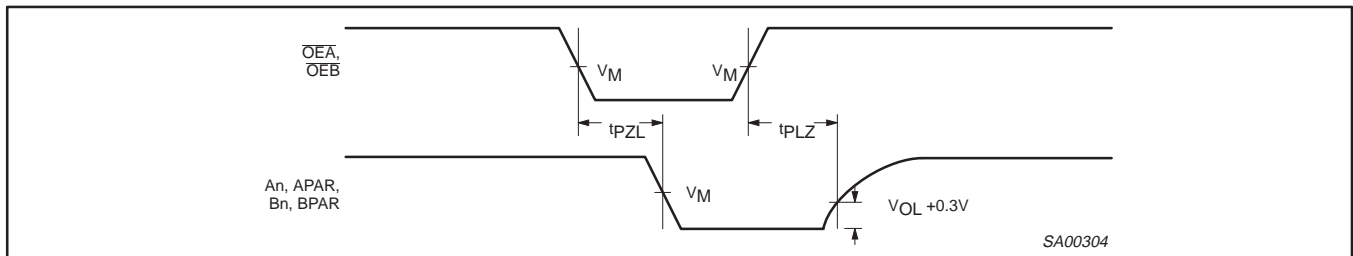

Waveform 12. 3-State Output Enable Time to Low Level and Output Disable Time from Low Level

TEST CIRCUIT AND WAVEFORM

TEST	S1
t_{pd}	open
t_{PLZ}/t_{PZL}	7 V
t_{PHZ}/t_{PZH}	open

DEFINITIONS
 C_L = Load capacitance includes jig and probe capacitance; see AC CHARACTERISTICS for value.

SA00012

9-bit dual latch transceiver with 8-bit parity generator/checker (3-State)

74ABT899

PLCC28: plastic leaded chip carrier; 28 leads; pedestal

SOT261-3

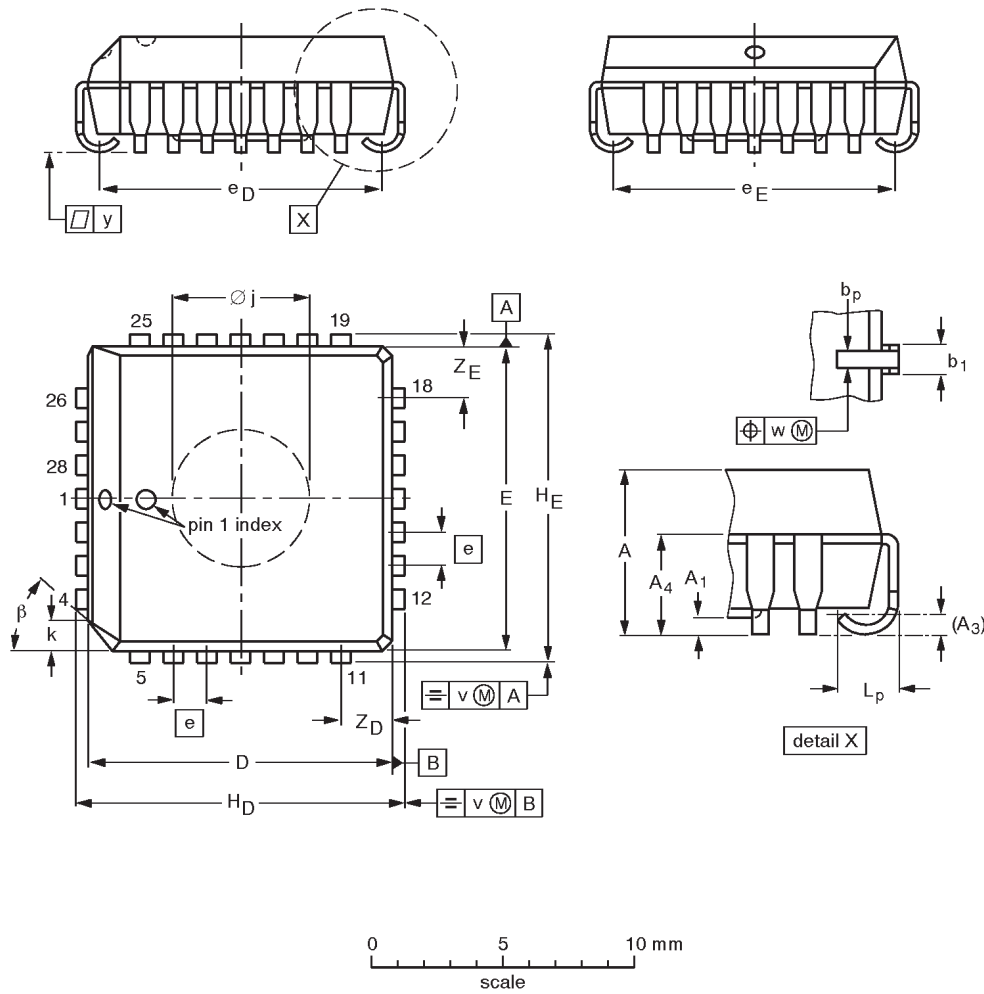

DIMENSIONS (millimetre dimensions are derived from the original inch dimensions)

UNIT	A	A ₁ min.	A ₃	A ₄ max.	b _p	b ₁	D ⁽¹⁾	E ⁽¹⁾	e	e _D	e _E	H _D	H _E	k	∅ _j	L _p	v	w	y	Z _D ⁽¹⁾ max.	Z _E ⁽¹⁾ max.	β
mm	4.57 4.19	0.13	0.25	3.05	0.53 0.33	0.81 0.66	11.58 11.43	11.58 11.43	1.27	10.92 9.91	10.92 9.91	12.57 12.32	12.57 12.32	1.22 1.07	5.69 5.54	1.44 1.02	0.18	0.18	0.10	2.06	2.06	45°
inches	0.180 0.165	0.005	0.01	0.12	0.021 0.013	0.032 0.026	0.456 0.450	0.456 0.450	0.05	0.430 0.390	0.430 0.390	0.495 0.485	0.495 0.485	0.048 0.042	0.224 0.218	0.057 0.040	0.007	0.007	0.004	0.081	0.081	

Note

1. Plastic or metal protrusions of 0.01 inches maximum per side are not included.

OUTLINE VERSION	REFERENCES			EUROPEAN PROJECTION	ISSUE DATE
	IEC	JEDEC	EIAJ		
SOT261-3		MO-047AB			95-02-25 97-12-16

9-bit dual latch transceiver with 8-bit parity generator/checker (3-State)

74ABT899

SO28: plastic small outline package; 28 leads; body width 7.5mm

SOT136-1

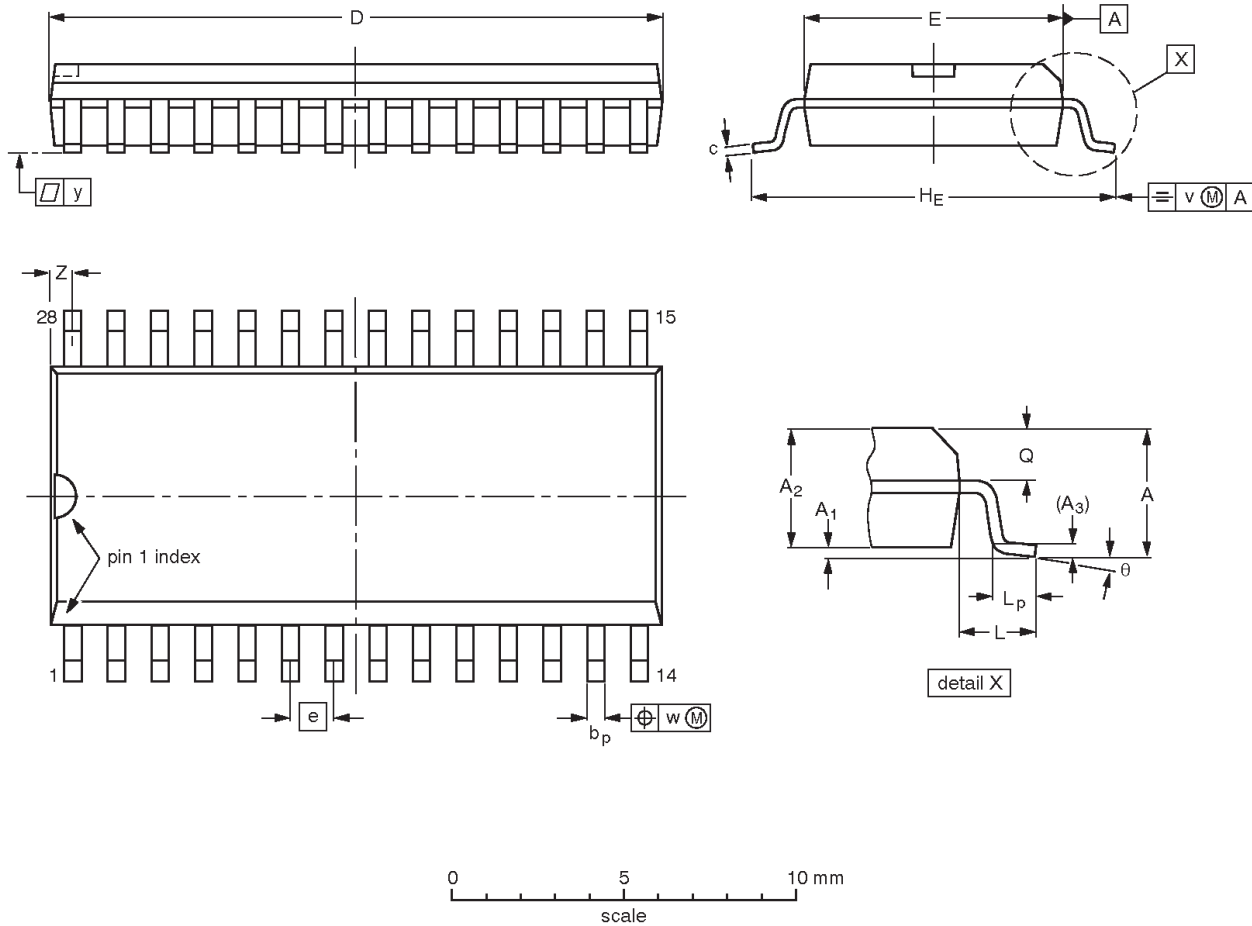

DIMENSIONS (inch dimensions are derived from the original mm dimensions)

UNIT	A max.	A ₁	A ₂	A ₃	b _p	c	D ⁽¹⁾	E ⁽¹⁾	e	H _E	L	L _p	Q	v	w	y	z ⁽¹⁾	θ
mm	2.65	0.30 0.10	2.45 2.25	0.25	0.49 0.36	0.32 0.23	18.1 17.7	7.6 7.4	1.27	10.65 10.00	1.4	1.1 0.4	1.1 1.0	0.25	0.25	0.1	0.9 0.4	8° 0°
inches	0.10	0.012 0.004	0.096 0.089	0.01	0.019 0.014	0.013 0.009	0.71 0.69	0.30 0.29	0.050	0.419 0.394	0.055	0.043 0.016	0.043 0.039	0.01	0.01	0.004	0.035 0.016	

Note

1. Plastic or metal protrusions of 0.15 mm maximum per side are not included.

OUTLINE VERSION	REFERENCES				EUROPEAN PROJECTION	ISSUE DATE
	IEC	JEDEC	EIAJ			
SOT136-1	075E06	MS-013AE				95-01-24 97-05-22

9-bit dual latch transceiver with 8-bit parity generator/checker (3-State)

74ABT899

SSOP28: plastic shrink small outline package; 28 leads; body width 5.3mm

SOT341-1

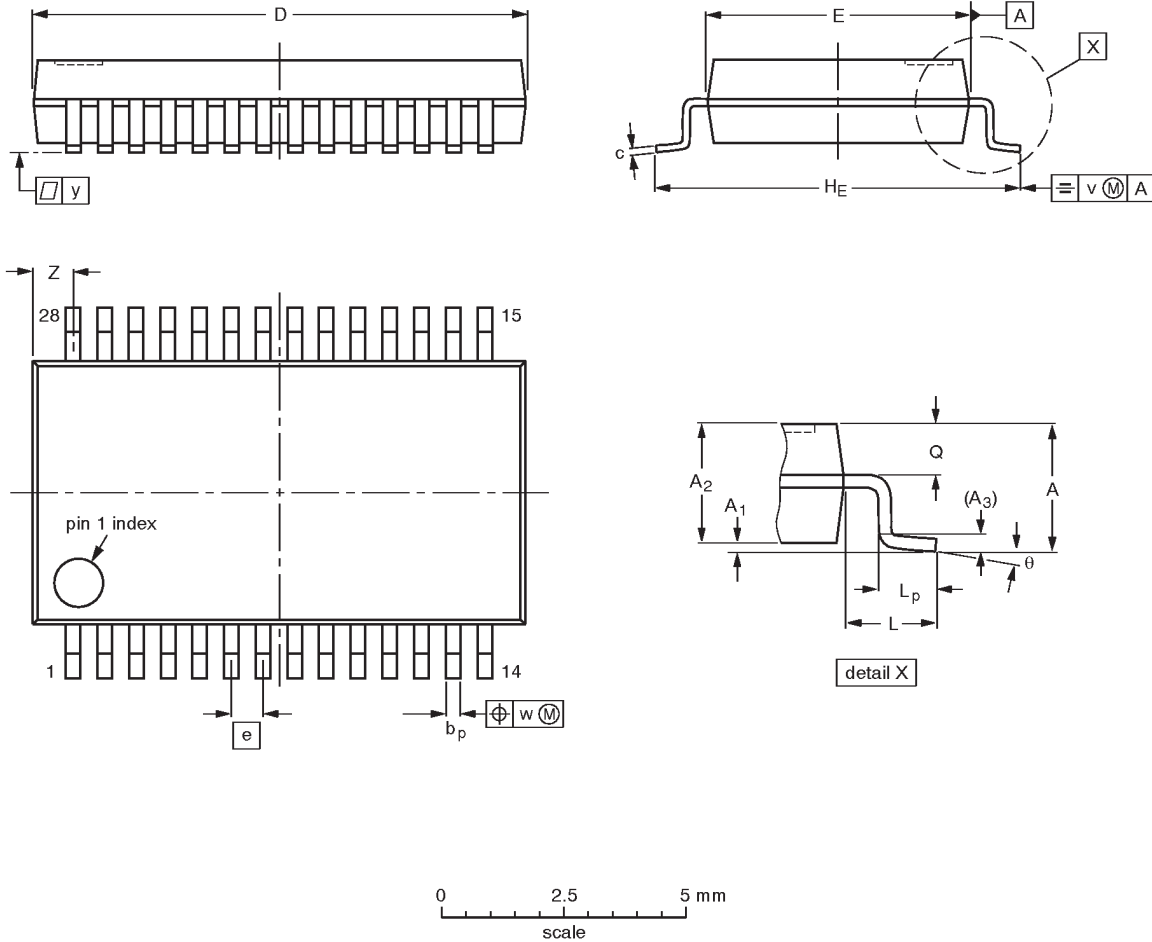

DIMENSIONS (mm are the original dimensions)

UNIT	A max.	A ₁	A ₂	A ₃	b _p	c	D ⁽¹⁾	E ⁽¹⁾	e	H _E	L	L _p	Q	v	w	y	Z ⁽¹⁾	θ
mm	2.0	0.21 0.05	1.80 1.65	0.25	0.38 0.25	0.20 0.09	10.4 10.0	5.4 5.2	0.65	7.9 7.6	1.25	1.03 0.63	0.9 0.7	0.2	0.13	0.1	1.1 0.7	8° 0°

Note

1. Plastic or metal protrusions of 0.20 mm maximum per side are not included.

OUTLINE VERSION	REFERENCES				EUROPEAN PROJECTION	ISSUE DATE
	IEC	JEDEC	EIAJ			
SOT341-1		MO-150AH				93-09-08 95-02-04

9-bit dual latch transceiver with 8-bit parity generator/checker (3-State)

74ABT899

Data sheet status

Data sheet status	Product status	Definition [1]
Objective specification	Development	This data sheet contains the design target or goal specifications for product development. Specification may change in any manner without notice.
Preliminary specification	Qualification	This data sheet contains preliminary data, and supplementary data will be published at a later date. Philips Semiconductors reserves the right to make changes at any time without notice in order to improve design and supply the best possible product.
Product specification	Production	This data sheet contains final specifications. Philips Semiconductors reserves the right to make changes at any time without notice in order to improve design and supply the best possible product.

[1] Please consult the most recently issued datasheet before initiating or completing a design.

Definitions

Short-form specification — The data in a short-form specification is extracted from a full data sheet with the same type number and title. For detailed information see the relevant data sheet or data handbook.

Limiting values definition — Limiting values given are in accordance with the Absolute Maximum Rating System (IEC 134). Stress above one or more of the limiting values may cause permanent damage to the device. These are stress ratings only and operation of the device at these or at any other conditions above those given in the Characteristics sections of the specification is not implied. Exposure to limiting values for extended periods may affect device reliability.

Application information — Applications that are described herein for any of these products are for illustrative purposes only. Philips Semiconductors make no representation or warranty that such applications will be suitable for the specified use without further testing or modification.

Disclaimers

Life support — These products are not designed for use in life support appliances, devices or systems where malfunction of these products can reasonably be expected to result in personal injury. Philips Semiconductors customers using or selling these products for use in such applications do so at their own risk and agree to fully indemnify Philips Semiconductors for any damages resulting from such application.

Right to make changes — Philips Semiconductors reserves the right to make changes, without notice, in the products, including circuits, standard cells, and/or software, described or contained herein in order to improve design and/or performance. Philips Semiconductors assumes no responsibility or liability for the use of any of these products, conveys no license or title under any patent, copyright, or mask work right to these products, and makes no representations or warranties that these products are free from patent, copyright, or mask work right infringement, unless otherwise specified.

Philips Semiconductors
811 East Arques Avenue
P.O. Box 3409
Sunnyvale, California 94088-3409
Telephone 800-234-7381

© Copyright Philips Electronics North America Corporation 1998
All rights reserved. Printed in U.S.A.

print code

Date of release: 05-96

Document order number:

9397-750-03478

Let's make things better.