

DC/DC LED Driver

Preliminary Product Specifications

High Power Constant Current LED Driver LD1040 Series

Total Power	40 Watts max.
Input Voltages	10 – 27VDC
Number of Outputs	One

ANZ#: Z189c, August 9, 2012

Features :

DC Output with Constant Current
1-10V dimming compatible
Meet FCC and CE standards
For Dry and Damp Locations
Convection Cooled in plastic housing
Terminal block for easy, fast installation
Three Year Warranty

Applications :

LED General Luminair
LED Architectural Lighting
LED Industrial Lighting
LED Emergency Lighting
LED General Luminair



Specifications :

Input Range : 10 ~ 27 VDC / 4.5A max.	Input Fuse / Reverse Polarity Protection : Yes
Efficiency : 93% Typical	MTBF(@25°C) : >100,000 Hours,MIL-217F
Protection : OPP,SCP - Auto Recovery	Meet UL safety standard
Operation Temp. : -30°C ~ +55°C, Tc : 80°C	FCC Class B, EN55015 compliant
Storage Temp. : -40°C ~ +85°C	Dimension : 141(L) x 45(W) x 26(H) mm +/- 0.5mm

Model Listing :

Features / Model	LD1040 Series				
	-36-C1100	-48-C0830	-60-C0670	-88-C0450	-100-C0250
Input Voltage (DC)	12-24VDC (-2 / +3V)	+24VDC (+/- 3V)	+24VDC (+/- 3V)	+24VDC (+/- 3V)	+24VDC (+/- 3V)
Efficiency	93% min.				
Operational Temperature	-30 ~ +50 °C				
Dimming	1-10 VDC				
Load Regulation	± 1%				
Forward Voltage Range (VDC)	18-40 ^{note2}	27-52	32-65	44-88	80-100
Max. Forward Current (mA)	1100	833	670	450	400
Max. Output (Watts)	40	40	40	40	40

Dimming Wiring Diagram :

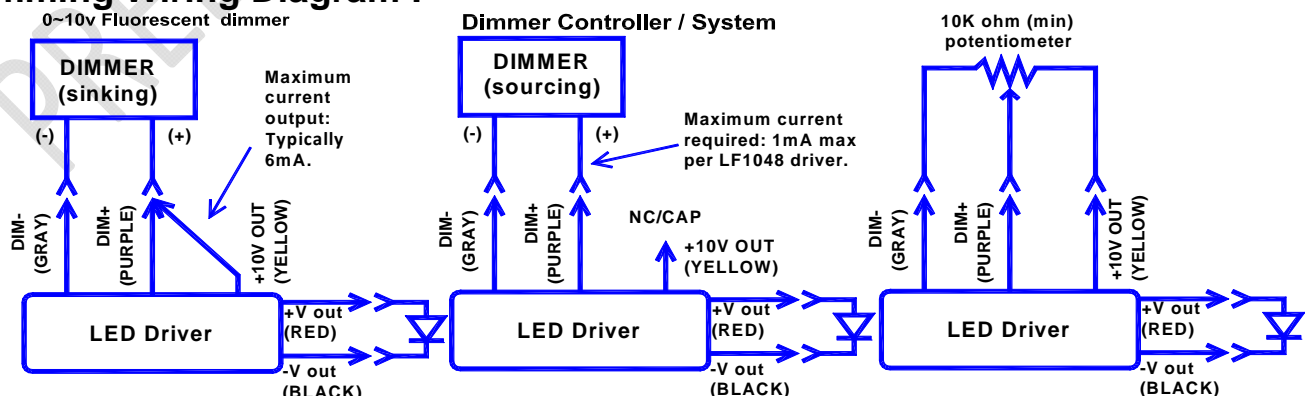

Note1: When DIM+, DIM- and +10V are left open, the output will be at the maximum rated current.

Note2: When input is greater than 18VDC, the Vf (forward voltage) has to be at least 2VDC higher than the input voltage.

Mechanical Specifications :

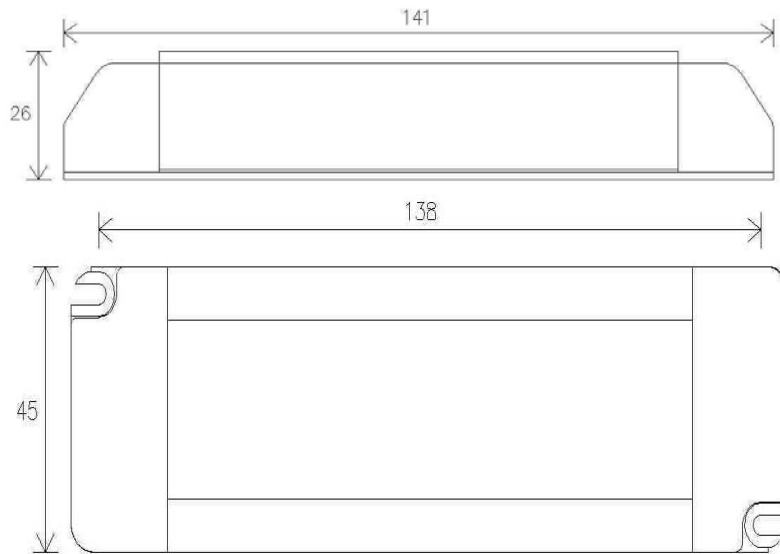

Derating

Temp. vs. Load :

Efficiency – Input vs. Load :

