

F81218D/DG

ISA/LPC to 6 UART Datasheet

Release Date: August, 2007
Version: V0.33P

F81218 Datasheet Revision History

Version	Date	Page	Revision History
0.24P	2003/7/10	25	Revised index 25h to index 26h
0.25P	2003/07/31	17	Updated WDT enable timer as power-on setting 24MHz clock input : 10 sec 48MHz clock input : 5 sec
0.26P	2003/09/16		Updated application circuit
0.27P	2004/01/07	56	Revised the pin naming, between Pin91 to Pin96
0.28P	2005/04/15	52	Added "Green Package" ordering information
		28	Added Full Duplex Function for IR self test (Bit 2 of IR control register index F1h)
		30	
0.29P	2006/03/24	-	Modified UART Clock Select Register (F0h) bit 1:0 description. Reserved 01/10/11 clock selection.
		-	Added flow control registers of UART1~ UART6 register F0h bit 4.
		-	Added AC timing characteristics description.
0.30P	2006/04/03	-	Modified RS485 register description
0.31P	2006/05/30	-	Added note description of AC Timing characteristics.
0.32P	2007/7/5	-	Company readdress
0.33P	2007/8/20	9	Modify typo of pin type (Pin 85,86,87,88,89)

Please note that all data and specifications are subject to change without notice. All the trade marks of products and companies mentioned in this data sheet belong to their respective owners.

LIFE SUPPORT APPLICATIONS

These products are not designed for use in life support appliances, devices, or systems where malfunction of these products can reasonably be expected to result in personal injury. Customers using or selling these products for use in such applications do so at their own risk and agree to fully indemnify Fintek for any damages resulting from such improper use or sales.

Table of Content

1. General Description	1
2. Feature List	1
3. Pin Configuration.....	2
4. Pin Description.....	3
4.1 ISA/LPC Interface	3
4.2 UART Interface.....	5
4.3 GPIO pins.....	10
4.4 Power	10
5. Functional Description.....	11
5.1 LPC Interface	11
5.2 UART.....	11
5.3 IR Function	16
5.4 Watch Dog Timer Function.....	17
5.5 Serial IRQ	18
6. Register Description.....	20
6.1 Global Control Register	23
6.1.1 Software Reset Register – index 02h	23
6.1.2 Logic Device Select Register – index 07h.....	24
6.1.3 Device ID Register– index 20h, 21h.....	24
6.1.4 Vendor ID Register– index 23h, 24h.....	24
6.1.5 Clock Source Select Register – index 25h.....	24
6.1.6 GPIO Function Select Register (ISA Interface Only) – index 26h.....	25
6.1.7 Test Mode Register – index 2Fh	25
6.2 UART 1 Device Control Register (LDN 0)	26
6.2.1 Device Enable Register – index 30h.....	26
6.2.2 I/O Port Select Register – index 60h.....	26
6.2.3 I/O Port Select Register – index 61h.....	26
6.2.4 IRQ Channel Select Register – index 70h	26
6.2.5 UART 1 Clock Select Register – index F0h	27
6.2.6 IR1 Control Register – index F1h.....	28
6.3 UART 2 Device Control Register (LDN 1)	28
6.3.1 Device Enable Register – index 30h.....	28
6.3.2 I/O Port Select Register – index 60h.....	28
6.3.3 I/O Port Select Register – index 61h.....	29
6.3.4 IRQ Channel Select Register – index 70h	29

F81218

6.3.5	UART 2 Clock Select Register – index F0h	30
6.3.6	IR 2 Control Register – index F1h.....	30
6.4	UART 3 Device Control Register (LDN 2)	31
6.4.1	Device Enable Register – index 30h.....	31
6.4.2	I/O Port Select Register – index 60h.....	31
6.4.3	I/O Port Select Register – index 61h.....	31
6.4.4	IRQ Channel Select Register – index 70h	31
6.4.5	UART 3 Clock Select Register – index F0h	32
6.5	UART 4 Device Control Register (LDN 3)	32
6.5.1	Device Enable Register – index 30h.....	32
6.5.2	I/O Port Select Register – index 60h.....	33
6.5.3	I/O Port Select Register – index 61h.....	33
6.5.4	IRQ Channel Select Register – index 70h	33
6.5.5	UART 4 Clock Select Register – index F0h	34
6.6	UART 5 Device Control Register (LDN 4)	34
6.6.1	Device Enable Register – index 30h.....	34
6.6.2	I/O Port Select Register – index 60h.....	34
6.6.3	I/O Port Select Register – index 61h.....	35
6.6.5	IRQ Channel Select Register – index 70h	35
6.6.6	UART 5 Clock Select Register – index F0h	36
6.7	UART 6 Device Control Register (LDN 5)	36
6.7.1	Device Enable Register – index 30h.....	36
6.7.2	I/O Port Select Register – index 60h.....	36
6.7.3	I/O Port Select Register – index 61h.....	36
6.7.4	IRQ Channel Select Register – index 70h	37
6.7.5	UART 6 Clock Select Register – index F0h	37
6.8	Address Decoder 0 Device Control Register (LDN 6)	38
6.8.1	Device Enable Register – index 30h.....	38
6.8.2	Address Decoder Select Register 0– index 60h.....	38
6.8.3	Address Decoder Select Register 1– index 61h.....	38
6.8.4	Address Mask Register – index 62h	38
6.8.5	IRQIN0 Channel Select Register (Only for LPC) – index 70h	39
6.9	Address Decoder 1 Device Control Register (LDN 7)	39
6.9.1	Device Enable Register – index 30h.....	39
6.9.2	Address Decoder Select Register 0 – index 60h.....	39
6.9.3	Address Decoder Select Register 1 – index 61h.....	40
6.9.4	Address Mask Register – index 62h	40

F81218

6.9.5	IRQIN1 Channel Select Register (Only for LPC) – index 70h	40
6.10	Watch Dog Timer Device Control Register (LDN 8)	41
6.10.1	Device Enable Register – index 30h.....	41
6.10.2	I/O Port Select Register – index 60h.....	41
6.10.3	I/O Port Select Register – index 61h.....	41
6.10.4	IRQ Channel Select Register – index 70h	41
6.10.5	Timer Status and Control Register – index F0h.....	42
6.10.6	Timer Count Number Register – index F1h.....	43
6.11	GPIO and PME Device Control Register (LDN 9).....	43
6.11.1	GPIO Port 2 Control Register – index F0h.....	43
6.11.2	GPIO Port 1 Control Register – index F1h.....	43
6.11.3	GPIO Port 2 Output Data Control Register – index F2h	44
6.11.4	GPIO Port 1 Output Data Register – index F3h	45
6.11.5	PME Event 1 Control Register – index F4h	45
6.11.6	PME Event 2 Control Register – index F5h	46
6.11.7	PME Event 3 Control Register – index F6h	47
6.11.8	GPIO Port 2 Input Status Register – index F7h.....	47
6.11.9	GPIO Port 1 Input Status Register – index F8h.....	48
6.11.10	PME Real Time Status Register – index F9h.....	48
6.11.11	PME Edge Status 1 Register – index FAh	48
6.11.12	PME Edge Status 2 Register – index FBh	49
6.11.13	PME Edge Status 3 Register – index FCh	49
7.	Electron Characteristic.....	51
7.1	Absolute Maximum Ratings	51
7.2	DC Characteristics	51
7.3	AC Timing Characteristics.....	53
8.	Ordering Information.....	54
9.	Package Dimensions	55
10.	Application Circuit.....	54

1. General Description

The F81218 mainly provides 4 pure UART and 2 SIR+UART ports through ISA or LPC interface which can be selected by hardware setting. Each UART includes 16-byte send/receive FIFO, a programmable baud rate generator, complete modem control capability and an interrupt system. When using ISA interface mode, total 6 IRQ can be used, and each one supports sharing function. 2 address decoder pins are provided for ISA mode as well. When in LPC interface mode, some pins such as DATA pins, IOR, IOW, address decoder, ISA address A0-A3 can be simple LPC to ISA transferring bridge pins. And some other pins can be set to be GPIO pins.

No matter in ISA or LPC mode, one watch dog timer is provided for system controlling and the time interval can be programmed by register or hardware power on setting pin. This IC needs one clock 24/48MHz input, and default is 24MHz. Powered by 3.3V voltage, the F81218 is in 100pin LQFP package (14mm x 14mm).

2. Feature List

- Supports LPC or ISA interface (1 hardware setting pin to define LPC or ISA I/F)
- In LPC mode, also provides simple LPC to ISA bridge
- Totally provides 6 UART (16550 asynchronous) ports
 - ◆ 4 pure UART ports
 - ◆ 2 SIR+ UART ports
- Provides 6 IRQ and each one can be shared
- 2 address decoder for ISA/LPC interface
- 1 watch dog timer with WDTOUT# signal
- 1 frequency input 24/48MHz
- Powered by 3Vcc
- 100-LQFP(14mm x 14mm)

F81218

3. Pin Configuration

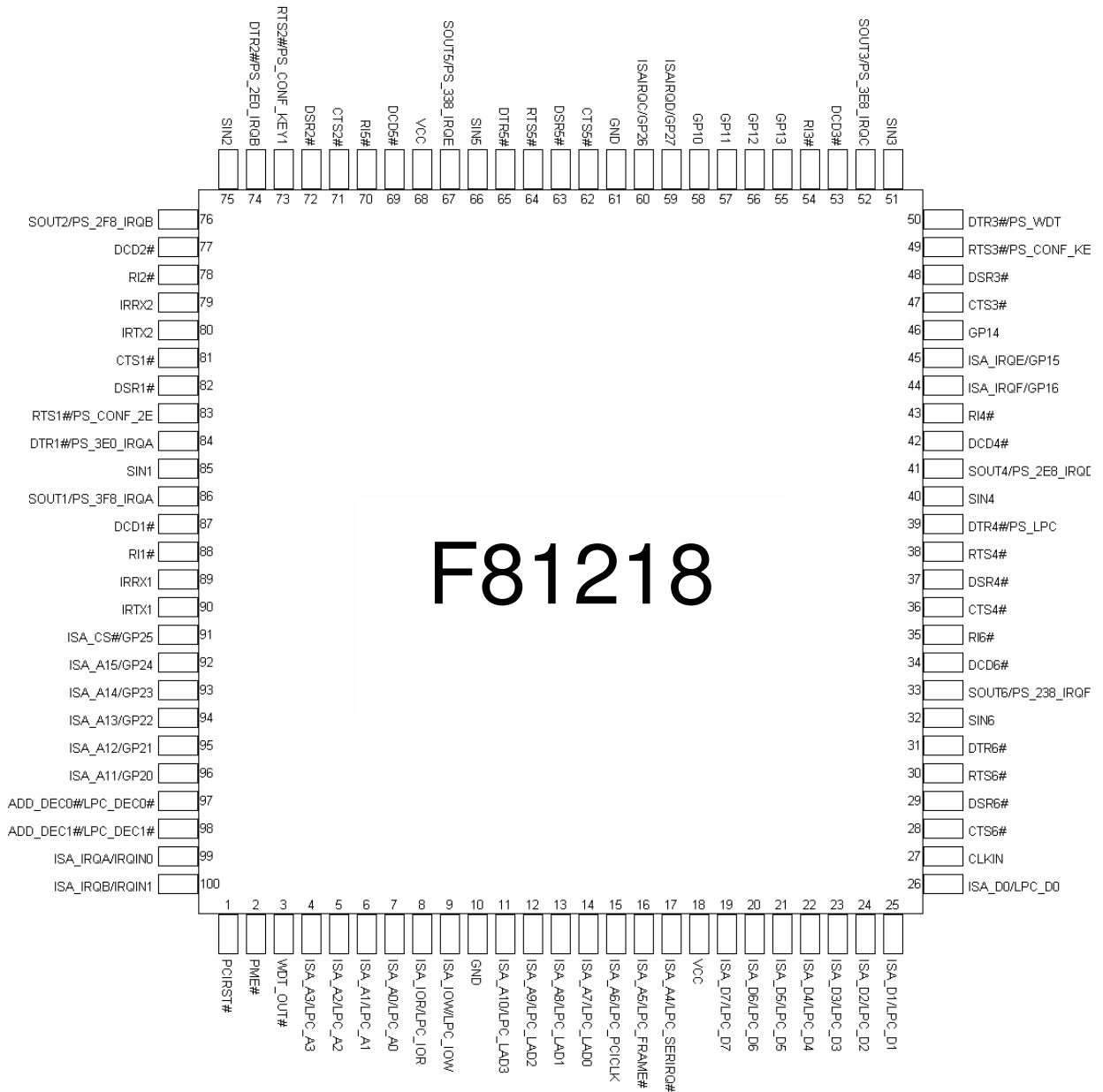

4. Pin Description

- I/O_{8t5V-d100} - TTL level bi-directional pin with 8 mA source-sink capability, 5V tolerance, pull-down 100K ohms
 I/O_{12t} - TTL level bi-directional pin with 12 mA source-sink capability
 I/OD₁₂ - TTL level bi-directional pin, Open-drain output with 12 mA sink capability
 PCI_{5V} - bi-direction pin, slew rate control, 5V tolerance.
 OUT₁₂ - Output pin with 12 mA source-sink capability
 OD₁₂ - Open-drain output pin with 12 mA sink capability
 IN_t - TTL level input pin
 IN_{t5V} - TTL level input pin and 5V tolerance.
 IN_{ts} - TTL level input pin and schmitt trigger
 IN_{ts5V} - TTL level input pin and Schmitt trigger, 5V tolerance.
 P - Power

4.1 ISA/LPC Interface

Pin No.	Pin Name	Type	Description
99	ISA_IRQA	O ₁₂	Default is ISA IRQ output
	IRQIN0	IN _{t5V}	When in LPC mode (pin 39 PS_LPC =1), the pin becomes LPC to ISA IRQ input. About IRQ index setting please refer to pin84 and pin86.
100	ISA_IRQB	O ₁₂	Default is ISA IRQ output,
	IRQIN1	IN _{t5V}	When in LPC mode (pin 39 PS_LPC =1), the pin becomes LPC to ISA IRQ input. About IRQ index setting please refer to pin74 and pin76.
1	PCIRST#	IN _{ts}	System PCI reset active low.
2	PME#	OD ₁₂	Generated PME event.
3	WDT_OUT#	OD ₁₂	Watch dog timer output. When pin 50 power on setting PS_WDT=0(default), Watch Dog timer time interval setting is programmed by register. Once power on setting PS_WDT=1, watch dog timer time interval will be fixed to 10 sec.

F81218

4~7	ISA_A[3:0]	PCI _{5V}	ISA address bus bit 0-3.
	LPC_A[3:0]		When in LPC mode, these pins become LPC to ISA address output.
8	ISA_IOR	IN _{15V}	CPU I/O read signal.
	LPC_IOR	OD ₁₂	When in LPC mode, these pin becomes LPC to ISA IOR output.
9	ISA_IOW	IN _{15V}	CPU I/O write signal.
	LPC_IOW	OD ₁₂	When in LPC mode, these pin becomes LPC to ISA IOW output.
11~14	ISA_A[10:7]	PCI _{5V}	ISA address bus bits 7-10.
	LPC_LAD[3:0]		When in LPC mode, these signal lines communicate address, control, and data information over the LPC bus between a host and a peripheral.
15	ISA_A6	IN _{15V}	ISA address bus bit 6
	LPC_PCICLK		In LPC mode, this pin acts as PCI clock input.
16	ISA_A5	IN _{15V}	ISA address bus bit 5
	LPC_LFRAME#		In LPC mode, indicates start of a new cycle or termination of a broken cycle.
17	ISA_A4	PCI _{5V}	ISA address bus bit 4.
	LPC_SERIRQ		In LPC mode, Serial IRQ input/Output.
19~26	ISA_D[7:0]	PCI _{5V}	ISA data bus bits 0-7
	LPC_D[7:0]		When in LPC mode, the pins become LPC to ISA data bus bits 0-7.
27	CLKIN	IN _t	System clock input. According to the input frequency 24MHz or 48MHz, it is selectable through register. Default is 24MHz input.
45	ISA_IRQE	O ₁₂	Default is ISA IRQ output , can act as GPIO function by programming register. About IRQ index setting please refer to pin67.
	GP15	IN _{15V}	When in LPC mode, this pin acts as GPIO function
44	ISA_IRQF	O ₁₂	Default is ISA IRQ output , can be GPIO by programming register. About IRQ index setting please refer to pin33.
	GP16	IN _{15V}	When in LPC mode, this pin acts as GPIO function

F81218

60	ISA_IRQC	O ₁₂	Default is ISA IRQ output
	LPC_GP26	IN _{t5V}	When in LPC mode (pin 39 PS_LPC =1), the pin becomes GPIO. About IRQ index setting please refer to pin52
59	ISA_IRQD	O ₁₂	Default is ISA IRQ output
	GP27	IN _{t5V}	When in LPC mode (pin 39 PS_LPC =1), the pin becomes GPIO. About IRQ index setting please refer to pin41.
92~96	ISA_A[15:11]	IN _t	ISA address bus bits 11-15.
	LPC_GP24	I/OD ₁₂	In LPC mode, these pins are all GPIO pins.
	LPC_GP23		
	LPC_GP22		
	LPC_GP21		
	LPC_GP20		
91	ISA_CS#	IN _t	ISA chip select pin.
	GP25	I/OD ₁₂	In LPC mode (pin 39 PS_LPC =1), this pin is GPIO.
98,97	ADD_DEC[1:0]#	OUT ₁₂	ISA address decoder,
	LPC_DEC[1:0]#	OD ₁₂	When in LPC mode (pin 39 PS_LPC =1), the pin becomes LPC to ISA address decoder.

4.2 UART Interface

Pin No.	Pin Name	Type	Description
28	CTS6#	IN _{t5V}	Clear To Send is the modem control input.
29	DSR6#	IN _{t5V}	Data Set Ready. An active low signal indicates the modem or data set is ready to establish a communication link and transfer data to the UART.
30	RTS6#	I/O _{8t5V-d100}	UART 6 Request To Send. An active low signal informs the modem or data set that the controller is ready to send data.
31	DTR6#	I/O _{8t5V-d100}	UART 6 Data Terminal Ready. An active low signal informs the modem or data set that controller is ready to communicate.
32	SIN6	IN _{t5V}	Serial Input. Used to receive serial data through the communication link.

F81218

33	SOUT6	I/O _{8t5V-d100}	UART 6 Serial Output. Used to transmit serial data out to the communication link.
	PS_238_IRQF		Power setting pin to define the IRQF index. Default PS_238_IRQF = 0 , IRQF index is programmed by register. If PS_238_IRQF = 1, setting IRQF index to 0x238
34	DCD6#	IN _{t5V}	Data Carrier Detect. An active low signal indicates the modem or data set has detected a data carrier.
35	RI6#	IN _{t5V}	Ring Indicator. An active low signal indicates that a ring signal is being received from the modem or data set.
36	CTS4#	IN _{t5V}	Clear To Send is the modem control input.
37	DSR4#	IN _{t5V}	Data Set Ready. An active low signal indicates the modem or data set is ready to establish a communication link and transfer data to the UART.
38	RTS4#	I/O _{8t5V-d100}	UART 4 Request To Send. An active low signal informs the modem or data set that the controller is ready to send data.
39	DTR4#	I/O _{8t5V-d100}	UART 4 Data Terminal Ready. An active low signal informs the modem or data set that controller is ready to communicate.
	PS_LPC		Power on setting pin to define the ISA or LPC interface. Default PS_LPC=0, ISA interface. When PS_LPC=1, transfer to LPC interface.
40	SIN4	IN _{t5V}	Serial Input. Used to receive serial data through the communication link.
41	SOUT4	I/O _{8t5V-d100}	UART 4 Serial Output. Used to transmit serial data out to the communication link.
	PS_2E8_IRQD		Power setting pin to define the IRQD index. Default PS_2E8_IRQD = 0 , IRQF index is programmed by register. If PS_2E8_IRQD = 1, setting IRQF index to 0x2E8.
42	DCD4#	IN _{t5V}	Data Carrier Detect. An active low signal indicates the modem or data set has detected a data carrier.
43	RI4#	IN _{t5V}	Ring Indicator. An active low signal indicates that a ring signal is being received from the modem or data set.
47	CTS3#	IN _{t5V}	Clear To Send is the modem control input.

F81218

48	DSR3#	IN _{t5V}	Data Set Ready. An active low signal indicates the modem or data set is ready to establish a communication link and transfer data to the UART.
49	RTS3#	I/O _{8t5V-d100}	UART 3 Request To Send. An active low signal informs the modem or data set that the controller is ready to send data.
	PS_CONF_KE Y0		Power on configuration setting pin. As for detail description, please refer to register description.
50	DTR3#	I/O _{8t5V-d100}	UART 3 Data Terminal Ready. An active low signal informs the modem or data set that controller is ready to communicate.
	PS_WDT		Power on setting pin to enable the watch dog timer. Default PS_WDT=0 , WDT time programmed by register. When PS_WDT=1, WDT time is defined as 10 sec.
51	SIN3	IN _{t5V}	Serial Input. Used to receive serial data through the communication link.
52	SOUT3	I/O _{8t5V-d100}	UART 3 Serial Output. Used to transmit serial data out to the communication link.
	PS_3E8_IRQC		Power setting pin to define the IRQC index. Default PS_3E8_IRQC = 0 , IRQF index is programmed by register. If PS_3E8_IRQC = 1, setting IRQC index to 0x3E8.
53	DCD3#	IN _{t5V}	Data Carrier Detect. An active low signal indicates the modem or data set has detected a data carrier.
54	RI3#	IN _{t5V}	Ring Indicator. An active low signal indicates that a ring signal is being received from the modem or data set.
62	CTS5#	IN _{t5V}	Clear To Send is the modem control input.
63	DSR5#	IN _{t5V}	Data Set Ready. An active low signal indicates the modem or data set is ready to establish a communication link and transfer data to the UART.
64	RTS5#	I/O _{8t5V-d100}	UART 5 Request To Send. An active low signal informs the modem or data set that the controller is ready to send data.
65	DTR5#	I/O _{8t5V-d100}	UART 5 Data Terminal Ready. An active low signal informs the modem or data set that controller is ready to communicate.
66	SIN5	IN _{t5V}	Serial Input. Used to receive serial data through the communication link.

F81218

67	SOUT5	I/O _{8t5V-d100}	UART 5 Serial Output. Used to transmit serial data out to the communication link.
	PS_338_IRQE		Power setting pin to define the IRQE index. Default PS_338_IRQE = 0 , IRQF index is programmed by register. If PS_338_IRQE = 1, setting IRQF index to 0x338.
69	DCD5#	IN _{t5V}	Data Carrier Detect. An active low signal indicates the modem or data set has detected a data carrier.
70	RI5#	IN _{t5V}	Ring Indicator. An active low signal indicates that a ring signal is being received from the modem or data set.
71	CTS2#	IN _{t5V}	Clear To Send is the modem control input.
72	DSR2#	IN _{t5V}	Data Set Ready. An active low signal indicates the modem or data set is ready to establish a communication link and transfer data to the UART.
73	RTS2#	I/O _{8t5V-d100}	UART 2 Request To Send. An active low signal informs the modem or data set that the controller is ready to send data.
	PS_CONF_KE Y1		Power on configuration setting pin. As for detail description, please refer to register description.
74	DTR2#	I/O _{8t5V-d100}	UART 2 Data Terminal Ready. An active low signal informs the modem or data set that controller is ready to communicate.
	PS_2E0_IRQB		Power setting pin to define the IRQB index. Default PS_2E0_IRQB = 0 , IRQB index is programmed by register. If PS_2E0_IRQB = 1, setting IRQB index to 0x2E0.
75	SIN2	IN _{t5V}	Serial Input. Used to receive serial data through the communication link.
76	SOUT2	I/O _{8t5V-d100}	UART 2 Serial Output. Used to transmit serial data out to the communication link.
	PS_2F8_IRQB		Power setting pin to define the IRQB index. Default PS_2F8_IRQB = 0 , IRQB index is programmed by register. If PS_2F8_IRQB = 1, setting IRQB index to 0x2F8.

F81218

77	DCD2#	IN _{t5V}	Data Carrier Detect. An active low signal indicates the modem or data set has detected a data carrier.
78	RI2#	IN _{t5V}	Ring Indicator. An active low signal indicates that a ring signal is being received from the modem or data set.
79	IRRX2	IN _{t5V}	Infrared Receiver input.
80	IRTX2	OUT ₁₂	Infrared Transmitter Output.
81	CTS1#	IN _{t5V}	Clear To Send is the modem control input.
82	DSR1#	IN _{t5V}	Data Set Ready. An active low signal indicates the modem or data set is ready to establish a communication link and transfer data to the UART.
83	RTS1#	I/O _{8t5V-d100}	UART 1 Request To Send. An active low signal informs the modem or data set that the controller is ready to send data.
	PS_CONF_2E		Power on configuration setting. Default PS_CONF_2E = 0, setting the configuration to 0x4E. If PS_CONF_2E = 1, setting the configuration to 0x2E.
84	DTR1#	I/O _{8t5V-d100}	UART 1 Data Terminal Ready. An active low signal informs the modem or data set that controller is ready to communicate.
	PS_3E0_IRQA		Power setting pin to define the IRQA index. Default PS_3E0_IRQA = 0 , IRQB index is programmed by register. If PS_3E0_IRQA = 1, setting IRQA index to 0x3E0.
85	SIN1	IN _{t5V}	Serial Input. Used to receive serial data through the communication link.
86	SOUT1	I/O _{8t5V-d100}	UART 1 Serial Output. Used to transmit serial data out to the communication link.
	PS_3F8_IRQA		Power setting pin to define the IRQA index. Default PS_3F8_IRQA = 0 , IRQA index is programmed by register. If PS_3F8_IRQA = 1, setting IRQA index to 0x3F8.
87	DCD1#	IN _{t5V}	Data Carrier Detect. An active low signal indicates the modem or data set has detected a data carrier.
88	RI1#	IN _{t5V}	Ring Indicator. An active low signal indicates that a ring signal is being received from the modem or data set.

F81218

89	IRRX1	IN _{ts5V}	Infrared Receiver input.
90	IRTX1	OUT ₁₂	Infrared Transmitter Output.

4.3 GPIO pins

Pin No.	Pin Name	Type	Description
46, 55~58	GPIO14 GPIO13 GPIO12 GPIO11 GPIO10	I/OD _{12t}	General purpose input/output pins.

4.4 Power

Pin No.	Pin Name	Type	Description
18,68	VCC	P	3.3V power supply.
10,61	GND	P	Ground.

Fintek Confidential
Do Not Copy!

5. Functional Description

The F81218 totally provides 6 UART ports through ISA or LPC interface which can be selected by hardware setting. Among 6 UART ports, two ports can support serial infrared communication. Besides, each UART includes 16-byte send/receive FIFO, a programmable baud rate generator, completed modem control capability and interrupt system. When using ISA interface mode, total 6 IRQ can be used, and each one supports sharing function (IRQ sharing). 2 address decoder pins are provided for ISA mode as well. When in LPC interface mode, some pins such as DATA pins, IOR, IOW, 2 address decoder, ISA address A0-A3 can be simple LPC to ISA transferring bridge pins. And some other pins can be set to be GPIO pins.

No matter in ISA or LPC mode, one watch dog timer is provided for system controlling and the time interval can be programmed by register or hardware power on setting pin. This IC needs one clock 24/48MHz input, and default is 24MHz. Powered by 3.3V voltage, the F81218 is in 100pin LQFP

5.1 LPC Interface

The F81218 can support LPC interface serving as a bus interface between host (chipset) and peripheral (I/O chip) by hardware trapping. This interface provides much less pins and more efficient transmission. Data transfer on the LPC bus is serialized over a 4 bit bus. The general characteristics of the interface implemented in F81218 are listed as below:

- ◆ One control line, namely LPC_FRAME#, which is used by the host to start or stop transfers. No peripherals drive this signal.
- ◆ The LPC_LAD[3:0] bus, which communicates information serially. The information conveyed is cycle type, cycle direction, chip selection, address, data, and wait states.
- ◆ PCIRST# is an active low reset signal.
- ◆ An additional 33 MHz PCI clock is needed in the F81218 for synchronization.
- ◆ Interrupt requests are issued through LPC_SERIRQ.
- ◆ Power management events are issued through PME#.

5.2 UART

F81218

A Universal Asynchronous Receiver/Transmitter (UART) is used to implement serial communication. The F81218 incorporates six fully function UART compatible with NS16550D. The UART ports perform serial to parallel conversion on receiving characters and parallel to serial conversion on transmitting characters. The controllable characteristics of the data transmission are baud rate, number of information bits per character, type of parity checking, number of stop bits and breaking the transmission. The serial format is a start bit, followed by five to eight data bits, a parity bit(if programmable), and one, one and half, or two stop bits. The UART also includes completed modem control capability and interrupt system that may be software trailed to the computing time required to handle the communication link. The UART also has a FIFO mode to reduce the number of interrupts presented to the CPU. In the UART, there is 16-byte FIFO for both receive and transmit mode.

5.2.1 UART Port Register

5.2.1.1 Receiver Buffer Register – Base + 0

Power-on default [7:0] = 0x00h.

Bit	Name	R/W	Description
7:0	RBR[7:0]	R	The data received . Read only when LCR[7] is 0

5.2.1.2 Transmitter Holding Register – Base + 0

Power-on default [7:0] = 0x00h.

Bit	Name	R/W	Description
7:0	THR[7:0]	W	Data to be transmitted. Write only when LCR[7] is 0

5.2.1.3 Divisor Latch (LS) – Base + 0

Power-on default [7:0] = 0x01h.

Bit	Name	R/W	Description
7:0	DLL[7:0]	R/W	Baud generator divisor low byte. Access only when LCR[7] is 1.

F81218

5.2.1.4 Divisor Latch (MS) – Base + 1

Power-on default [7:0] = 0x00h.

Bit	Name	R/W	Description
7:0	DLM[7:0]	R/W	Baud generator divisor high byte. Access only when LCR[7] is 1.

5.2.1.5 Interrupt Enable Register – Base + 1

Power-on default [7:0] = 0x00h.

Bit	Name	R/W	Description
7:4	Reserved	R/W	Return 0 when read. Access only when LCR[7] is 0
3	EDSSI	R/W	Enable Modem Status Interrupt. Access only when LCR[7] is 0.
2	ELSI	R/W	Enable Line Status Error Interrupt. Access only when LCR[7] is 0.
1	ETBFI	R/W	Enable Transmitter Holding Register Empty Interrupt. Access only when LCR[7] is 0.
0	ERBFI	R/W	Enable Received Data Available Interrupt. Access only when LCR[7] is 0

5.2.1.6 Interrupt Identification Register – Base + 2

Power-on default [7:0] = 0x01h.

Bit	Name	R/W	Description
7	FIFO_EN	R	0 : FIFO is disabled 1 : FIFO is enabled.
6	FIFO_EN	R	0 : FIFO is disabled. 1 : FIFO is enabled.
5:4	Reserved	R	Return 0 when read.
3:1	IRQ_ID[2:0]	R	000 : Interrupt is caused by Modem Status 001 : Interrupt is caused by Transmitter Holding Register Empty 010 : Interrupt is caused by Received Data Available. 110 : Interrupt is caused by Character Timeout 011 : Interrupt is caused by Line Status..
0	IRQ_PENDN	R	1 : Interrupt is not pending. 0 : Interrupt is pending.

F81218

5.2.1.7 FIFO Control Register – Base + 2

Power-on default [7:0] = 0x00h.

Bit	Name	R/W	Description
7:6	RCVR_TRIG[1:0]	W	00 : Receiver FIFO trigger level is 1. 01 : Receiver FIFO trigger level is 4. 10 : Receiver FIFO trigger level is 8. 11 : Receiver FIFO trigger level is 14.
5:3	Reserved	W	
2	CLRTX	W	1 : Reset the transmitter FIFO.
1	CLRRX	W	1 : Reset the receiver FIFO.
0	FIFO_EN	W	0 : Disable FIFO 1 : Enable FIFO

5.2.1.8 Line Control Register – Base + 3

Power-on default [7:0] = 0x00h.

Bit	Name	R/W	Description
7	DLAB	R/W	0 : Divisor Latch can't be accessed. 1 : Divisor Latch can be accessed via Base and Base+1.
6	SETBRK	R/W	1 : Transmit a break condition. 0 : Transmitter is in normal condition.
5:3	STKPAR EPS PEN	R/W	XX0 : Parity Bit is disable 001 : Parity Bit is odd. 011 : Parity Bit is even 101 : Parity Bit is logic 1 111 : Parity Bit is logic 0
2	STB	R/W	0 : Stop bit is one bit 1 : When word length is 5 bit stop bit is 1.5 bit else stop bit is 2 bit
1:0	WLS[1:0]	R/W	00 : Word length is 5 bit 01 : Word length is 6 bit 10 : Word length is 7 bit 11 : Word length is 8 bit

5.2.1.9 MODEM Control Register – Base + 4

Power-on default [7:0] = 0x00h.

Bit	Name	R/W	Description
7:5	Reserved	R/W	Return 0 when read.
4	LOOP	R/W	0 : UART in normal condition. 1 : UART is internal loop back
3	OUT2	R/W	0 : All interrupt is disable. 1 : Interrupt is enabled/disabled by IER.
2	OUT1	R/W	Read from MSR[6] is loop back mode
1	RTS	R/W	0 : RTS# is forced to logic 1 1 : RTS# is forced to logic 0
0	DTR	R/W	0 : DTR# is forced to logic 1 1 : DTR# is forced to logic 0

5.2.1.10 Line Status Register – Base + 5

Power-on default [7:0] = 0x60h.

Bit	Name	R/W	Description
7	RCR_ERR	R	0 : No error in the FIFO when FIFO is enabled 1 : Error in the FIFO when FIFO is enabled.
6	TEMT	R	0 : Transmitter is in transmitting. 1 : Transmitter is empty.
5	THRE	R	0 : Transmitter Holding Register is not empty. 1 : Transmitter Holding Register is empty.
4	BI	R	0 : No break condition detected. 1 : A break condition is detected.
3	FE	R	0 : Data received has no frame error. 1 : Data received has frame error.
2	PE	R	0 : Data received has no parity error. 1 : Data received has parity error.
1	OE	R	0 : No overrun condition occur. 1 : A overrun condition occur.
0	DR	R	0 : No data is ready for read. 1 : Data is received .

F81218

5.2.1.11 MODEM Status Register – Base + 6

Power-on default [7:0] = 0xX0h.

Bit	Name	R/W	Description
7	DCD	R	Complement of DCD# input. In loop back mode, this bit is equivalent to OUT2 in MCR.
6	RI	R	Complement of RI# input. In loop back mode, this bit is equivalent to OUT1 in MCR
5	DSR	R	Complement of DSR# input. In loop back mode, this bit is equivalent to DTR in MCR
4	CTS	R	Complement of CTS# input. In loop back mode, this bit is equivalent to RTS in MCR
3	DDCD	R	0 : No state changed at DCD#. 1 : State changed at DCD#.
2	TERI	R	0 : No Trailing edge at RI#. 1 : A low to high transition at RI#.
1	DDSR	R	0 : No state changed at DSR#. 1 : State changed at DSR#.
0	DCTS	R	0 : No state changed at CTS#. 1 : State changed at CTS#.

5.2.1.11 Scratch Register – Base + 7

Power-on default [7:0] = 0x00h.

Bit	Name	R/W	Description
7:0	SCR_DATA[7:0]	R/W	Scratch register.

5.3 IR Function

The F81218 infrared interface provides a two way wireless communications port using infrared as the transmission medium. The IrDA 1.0 (SIR) is found in UART1 and UART2. IrDA SIR specifies asynchronous serial communication at baud rate up to 115.2Kbps. Each byte is sent serial LSB first beginning with a zero value start bit. A zero is signaled by sending a single infrared pulse at the beginning of the serial bit time. A one is signaled by the absence of an infrared pulse during the

F81218

bit time. IRTX acts as a transmit pin and IRRX acts as a receiving one. As for detail description, please refer to register description.

5.4 Watch Dog Timer Function

Watch dog timer is provided for system controlling. If time-out can trigger one signal to low level, the signal default is tri-state (need external pull up resister).

The time interval has three ways:

One is the hardware power on setting to enable, timer set to 10 second (24MHz). If 48MHz clock input, the timer is set to 5 second.

Two is programmed by registers.

The other is set the base address into registers, and use the base address the control it.

The timer unit has three kinds: 10mS, 1S, 1Min.

5.4.1 Watchdog Port Register

5.4.1.1 Timer Status and Control Register – Base + 0

Power-on default [7:0] = 0x02 when DTR3#/PS_WDT is pull-up, else 0x0.

Bit	Name	R/W	Description
7:3	Reserved	R/W	Return 0 when read.
2:1	WDT_UNIT[1:0]	R/W	00 : Timer Unit is 10ms. 01 : Timer Unit is 1 second 10 : Timer Unit is 1 minute. 11 : reserved.
0	WDT_EVENT	R/W	When read 0 : no time out occur. 1 : time out has occurred. when write 0 : no action 1 : clear the time out status.

5.4.1.2 Timer Count Number Register – Base + 1

Power-on default [7:0] = 0x0Ah when DTR3#/PS_WDT is pull-up , else 0x00h.

Bit	Name	R/W	Description
7:0	WDT_CNT[7:0]	R/W	The number of count for watchdog timer.

F81218

			Write the same value to enable the timer, write 0 to disable timer.
--	--	--	---

5.5 Serial IRQ

F81218 supports a serial IRQ scheme. This allows a signal line to be used to report the legacy ISA interrupt requests. Because more than one device may need to share the signal serial IRQ signal line, an open drain signal scheme is used. The clock source is the PCI clock. The serial interrupt is transferred on the SERIRQ signal, one cycle consisting of three frames types: a start frame, several IRQ/Data frame, and one Stop frame.

5.5.1 Start Frame

There are two modes of operation for the SERIRQ Start frame: Quiet mode and Continuous mode. In the Quiet mode, the peripheral drives the SERIRQ signal active low for one clock, and then tri-states it. This brings all the states machines of the peripherals from idle to active states. The host controller will then take over driving SERIRQ signal low in the next clock and will continue driving the SERIRQ low for programmable 3 to 7 clock periods. This makes the total number of clocks low for 4 to 8 clock periods. After these clocks, the host controller will drive the SERIRQ high for one clock and then tri-states it. In the Continuous mode, only the host controller initiates the START frame to update IRQ/Data line information. The host controller drives the SERIRQ signal low for 4 to 8 clock periods. Upon a reset, the SERIRQ signal is defaulted to the Continuous mode for the host controller to initiate the first Start frame.

5.5.2 IRQ/Data Frame

Once the start frame has been initiated, all the peripherals must start counting frames based on the rising edge of the start pulse. Each IRQ/Data Frame is three clocks: Sample phase, Recovery phase, and Turn-around phase. During the Sample phase, the peripheral drives SERIRQ low if the corresponding IRQ is active. If the corresponding IRQ is inactive, then SERIRQ must be left tri-stated. During the Recovery phase, the peripheral device drives the SERIRQ high. During the Turn-around phase, the peripheral device left the SERIRQ tri-stated. The IRQ/Data Frame has a number of specific order, as shown in Table 5-1. The F81218 is only support IRQ3, IRQ4, IRQ5, IRQ9, IRQ10, and IRQ11.

Table 5-1 IRQSER Sampling periods

F81218

IRQ/Data Frame	Signal Sampled	# of clocks past Start
1	IRQ0	2
2	IRQ1	5
3	SMI#	8
4	IRQ3	11
5	IRQ4	14
6	IRQ5	17
7	IRQ6	20
8	IRQ7	23
9	IRQ8	26
10	IRQ9	29
11	IRQ10	32
12	IRQ11	35
13	IRQ12	38
14	IRQ13	41
15	IRQ14	44
16	IRQ15	47
17	IOCHCK#	50
18	INTA#	53
19	INTB#	56
20	INTC#	59
21	INTD#	62
32:22	Unassigned	95

5.5.3 Stop Frame

After all IRQ/Data Frames have completed, the host controller will terminate SERIRQ by a Stop frame. Only the host controller can initiate the Stop frame by driving SERIRQ low for 2 or 3 clocks. If the Stop Frame is low for 2 clocks, the next SERIRQ cycle's Sample mode is the Quiet mode. If the Stop Frame is low for 3 clocks, the next SERIRQ cycle's Sample mode is the Continuous mode.

6. Register Description

Registers are programmed by port 0x4E and 0x4F. 0x4E is the index port and 0x4F is the data port . To enable configuration registers programming, entry key must output twice to index port continuously. The entry key is decided by power on setting pins RTS2#/PS_CONF_KEY1 and RTS3#/PS_CONF_KEY0 as following:

RTS2#/PS_CONF_KEY1	RTS3#/PS_CONF_KEY0	Entry key
0	0	0x77 (default)
0	1	0xA0
1	0	0x87
1	1	0x67

To exit configuration registers programming, output 0xAA to index port.

Sample code for configuration:

1. Clock in used 48MHz, UART 1~6 address (0x3f8, 0x2f8, 0x3e8, 0x2e8, 0x3e0, 0x2e0), IRQ(3, 4, 5, 9, 10, 11, Entry key is 0x77:

```

outportb(0x4e, 0x77);
outportb(0x4e, 0x77); //Entry configuration mode
outportb(0x4e, 0x25); //Select register index 0x25
outportb(0x4f, 0x01); //Set bit 0 to 1 select clock input to 48MHz
outportb(0x4e, 0x07); //Select register index 0x07
outportb(0x4f, 0x00); //Select LDN 0
outportb(0x4e, 0x60); //Select LDN 0 register index 0x60
outportb(0x4f, 0x03); //Set UART 1 base address high byte to 0x03
outportb(0x4e, 0x61); //Select LDN 0 register index 0x61
outportb(0x4f, 0xf8); //Set UART 1 base address low byte to 0xf8
outportb(0x4e, 0x70); //Select LDN 0 register index 0x70
outportb(0x4f, 0x03); //Set UART 1 interrupt channel to IRQ 3
outportb(0x4e, 0x30); //Select LDN 0 register index 0x30
outportb(0x4f, 0x01); //Enable UART 1

outportb(0x4e, 0x07); //Select register index 0x07
outportb(0x4f, 0x01); //Select LDN 1
outportb(0x4e, 0x60); //Select LDN 1 register index 0x60
    
```

F81218

```
outportb(0x4f, 0x02); //Set UART 2 base address high byte to 0x02
outportb(0x4e, 0x61); //Select LDN 1 register index 0x61
outportb(0x4f, 0xf8); //Set UART 2 base address low byte to 0xf8
outportb(0x4e, 0x70); //Select LDN 1 register index 0x70
outportb(0x4f, 0x04); //Set UART 2 interrupt channel to IRQ 4
outportb(0x4e, 0x30); //Select LDN 1 register index 0x30
outportb(0x4f, 0x01); //Enable UART 2
```

```
outportb(0x4e, 0x07); //Select register index 0x07
outportb(0x4f, 0x02); //Select LDN 2
outportb(0x4e, 0x60); //Select LDN 2 register index 0x60
outportb(0x4f, 0x03); //Set UART 3 base address high byte to 0x03
outportb(0x4e, 0x61); //Select LDN 2 register index 0x61
outportb(0x4f, 0xe8); //Set UART 3 base address low byte to 0xe8
outportb(0x4e, 0x70); //Select LDN 2 register index 0x70
outportb(0x4f, 0x05); //Set UART 3 interrupt channel to IRQ 5
outportb(0x4e, 0x30); //Select LDN 2 register index 0x30
outportb(0x4f, 0x01); //Enable UART 3
```

```
outportb(0x4e, 0x07); //Select register index 0x07
outportb(0x4f, 0x03); //Select LDN 3
outportb(0x4e, 0x60); //Select LDN 3 register index 0x60
outportb(0x4f, 0x02); //Set UART 4 base address high byte to 0x02
outportb(0x4e, 0x61); //Select LDN 3 register index 0x61
outportb(0x4f, 0xe8); //Set UART 4 base address low byte to 0xe8
outportb(0x4e, 0x70); //Select LDN 3 register index 0x70
outportb(0x4f, 0x09); //Set UART 4 interrupt channel to IRQ 9
outportb(0x4e, 0x30); //Select LDN 3 register index 0x30
outportb(0x4f, 0x01); //Enable UART 4
```

```
outportb(0x4e, 0x07); //Select register index 0x07
outportb(0x4f, 0x04); //Select LDN 4
outportb(0x4e, 0x60); //Select LDN 4 register index 0x60
outportb(0x4f, 0x03); //Set UART 5 base address high byte to 0x03
outportb(0x4e, 0x61); //Select LDN 4 register index 0x61
outportb(0x4f, 0xe0); //Set UART 5 base address low byte to 0xe0
outportb(0x4e, 0x70); //Select LDN 4 register index 0x70
```

F81218

```

outportb(0x4f, 0x0a); //Set UART 5 interrupt channel to IRQ 10
outportb(0x4e, 0x30); //Select LDN 4 register index 0x30
outportb(0x4f, 0x01); //Enable UART 5

outportb(0x4e, 0x07); //Select register index 0x07
outportb(0x4f, 0x05); //Select LDN 5
outportb(0x4e, 0x60); //Select LDN 5 register index 0x60
outportb(0x4f, 0x02); //Set UART 6 base address high byte to 0x02
outportb(0x4e, 0x61); //Select LDN 5 register index 0x61
outportb(0x4f, 0xe0); //Set UART 6 base address low byte to 0xe0
outportb(0x4e, 0x70); //Select LDN 5 register index 0x70
outportb(0x4f, 0x0b); //Set UART 6 interrupt channel to IRQ 11
outportb(0x4e, 0x30); //Select LDN 5 register index 0x30
outportb(0x4f, 0x01); //Enable UART 6
outportb(0x4e, 0xaa); //Exit configuration mode
    
```

2. Set Address decoder 0 to decode 0x380~0x387:

```

outportb(0x4e, 0x77);
outportb(0x4e, 0x77); //Entry configuration mode
outportb(0x4e, 0x07); //Select register index 0x07
outportb(0x4f, 0x06); //Select LDN 6
outportb(0x4e, 0x60); //Select LDN 6 register index 0x60
outportb(0x4f, 0x03); //Set Address decoder 0 base address high byte to 0x03
outportb(0x4e, 0x61); //Select LDN 6 register index 0x61
outportb(0x4f, 0x80); //Set Address decoder 0 base address low byte to 0x80
outportb(0x4e, 0x62); //Select LDN 6 register index 0x62
outportb(0x4f, 0x03); //Set Address decoder 0 base address mask 3 bit
outportb(0x4e, 0x30); //Select LDN 6 register index 0x30
outportb(0x4f, 0x01); //Enable Address decoder 0 Device
outportb(0x4e, 0xaa); //Exit configuration mode
    
```

3. Set Address decoder 1 to decode 0x480~0x480:

```

outportb(0x4e, 0x77);
outportb(0x4e, 0x77); //Entry configuration mode
outportb(0x4e, 0x07); //Select register index 0x07
outportb(0x4f, 0x07); //Select LDN 7
outportb(0x4e, 0x60); //Select LDN 7 register index 0x60
    
```

F81218

```

outportb(0x4f, 0x04); //Set Address decoder 1 base address high byte to 0x04
outportb(0x4e, 0x61); //Select LDN 7 register index 0x61
outportb(0x4f, 0x80); //Set Address decoder 1 base address low byte to 0x80
outportb(0x4e, 0x62); //Select LDN 7 register index 0x62
outportb(0x4f, 0x00); //Set Address decoder 0 base address decode A0~A15
outportb(0x4e, 0x30); //Select LDN 7 register index 0x30
outportb(0x4f, 0x01); //Enable Address decoder 1 Device
outportb(0x4e, 0xaa); //Exit configuration mode
    
```

4. Set Watch Dog timer base address 0x300~0x301:

```

outportb(0x4e, 0x77);
outportb(0x4e, 0x77); //Entry configuration mode
outportb(0x4e, 0x07); //Select register index 0x07
outportb(0x4f, 0x08); //Select LDN 8
outportb(0x4e, 0x60); //Select LDN 8 register index 0x60
outportb(0x4f, 0x03); //Set Watch Dog timer base address high byte to 0x03
outportb(0x4e, 0x61); //Select LDN 8 register index 0x61
outportb(0x4f, 0x00); //Set Watch Dog Timer base address low byte to 0x00
outportb(0x4e, 0x30); //Select LDN 8 register index 0x30
outportb(0x4f, 0x01); //Enable Watch Dog Timer Device
outportb(0x4e, 0xaa); //Exit configuration mode
    
```

5. Set Watch Dog timer to 20 second used base address 0x300~0x301:

```

outportb(0x300, 0x03); //Select unit to one second and clear time out status
outportb(0x301, 0x14);
outportb(0x301, 0x14); //Set timer to 20 second and enable timer
    
```

6.1 Global Control Register

6.1.1 Software Reset Register – index 02h

Power-on default [7:0] = 0x00h

Bit	Name	R/W	Description
7:1	Reserved	R/W	Return 0 when read.
0	SWRST	R/W	Write 1 to reset configuration register. This bit is auto cleared.

6.1.2 Logic Device Select Register – index 07h

Power-on default [7:0] = 0x00h

Bit	Name	R/W	Description
7:0	LDN[7:0]	R/W	00h : Select UART 1 device configuration register 01h : Select UART 2 device configuration register 02h : Select UART 3 device configuration register 03h : Select UART 4 device configuration register 04h : Select UART 5 device configuration register 05h : Select UART 6 device configuration register 06h : Select Address Decoder 1 device configuration register 07h : Select Address Decoder 2 device configuration register 08h : Select Watchdog Timer device configuration register 09h : Select GPIO and PME device configuration register

6.1.3 Device ID Register– index 20h, 21h

Power-on default [7:0], 0x02h for index 20h, 0x06h for index 21h

Bit	Name	R/W	Description
7:0	DEVID	R	Return 0206h when read index 20h and 21h respectively, indicate the device ID.

6.1.4 Vendor ID Register– index 23h, 24h

Power-on default [7:0], 0x19h for index 23h, 0x34h for index 24h

Bit	Name	R/W	Description
7:0	VENDID	R	Return 1934h when read index 23h and 24h respectively, indicate the vendor ID of Fintek.

6.1.5 Clock Source Select Register – index 25h

Power-on default [7:0], 0x00h

Bit	Name	R/W	Description
7:1	Reserved	R/W	Return 0 when read.
0	CLK_SEL	R/W	1 : The CLKIN is 48MHz

F81218

			0 : The CLKIN is 24MHz. This bit must program to indicate the frequency of the clock source, or the device will not function correctly.
--	--	--	--

6.1.6 GPIO Function Select Register (ISA Interface Only) – index 26h

Power-on default [7:0],0x00h

Bit	Name	R/W	Description
7:4	Reserved	R/W	Return 0 when read.
3	GP16_SEL	R/W	1 : ISA_IRQF/GP16 functions as GPIO. 0 : ISA_IRQF/GP16 functions as ISA_IRQF. In LPC mode , ISA_IRQF/GP16 functions as GP16
2	GP15_SEL	R/W	1 : ISA_IRQE/GP15 functions as GPIO. 0 : ISA_IRQE/GP15 functions as ISA_IRQE. In LPC mode , ISA_IRQE/GP15 functions as GP15
1	GP27_SEL	R/W	1 : ISA_IRQD/GP26 functions as GPIO. 0 : ISA_IRQD/GP26 functions as ISA_IRQD. In LPC mode , ISA_IRQD/GP27 functions as GP27
0	GP26_SEL	R/W	1 : ISA_IRQC/GP25 functions as GPIO. 0 : ISA_IRQC/GP25 functions as ISA_IRQC. In LPC mode , ISA_IRQC/GP26 functions as GP26

6.1.7 Test Mode Register – index 2Fh

Power-on default [7:0], 0000_0000b

Bit	Name	R/W	Description
7:0	TESTMODE	R/W	Test mode register, reserved for Fintek use only.

6.2 UART 1 Device Control Register (LDN 0)

6.2.1 Device Enable Register – index 30h

Power-on default [7:0] = 0x01h when SOUT1/PS_3F8_IRQA or DTR1#/PS_3E0_IRQA is pull-up, else 0x00h.

Bit	Name	R/W	Description
7:1	Reserved	R/W	Return 0 when read.
0	URA_EN	R/W	0 : Disable UART 1. 1 : Enable UART 1..

6.2.2 I/O Port Select Register – index 60h

Power-on default [7:0] = 0x03h when SOUT1/PS_3F8_IRQA or DTR1#/PS_3E0_IRQA is pullup, else 0x00h.

Bit	Name	R/W	Description
7:0	URA_BASE[15:8]	R/W	UART 1 I/O Port Address high byte.

6.2.3 I/O Port Select Register – index 61h

Power-on default [7:0] = 0xF8h when SOUT1/PS_3F8_IRQA is pull-up, 0xE0h when DTR1#/PS_3E0_IRQA is pull-up, else 0x00h.

Bit	Name	R/W	Description
7:0	URA_BASE[7:0]	R/W	UART 1 I/O Port Address low byte.

6.2.4 IRQ Channel Select Register – index 70h

Power-on default [7:0] = 0x03h when SOUT1/PS_3F8_IRQA or DTR1#/PS_3E0_IRQA is pull-up, else 0x00h

Bit	Name	R/W	Description
7:6	Reserved	R/W	Return 0 when read.
5	URAIRQ_MODE	R/W	0 : PCI IRQ sharing mode. 1 : ISA IRQ sharing mode. This bit is effective in IRQ sharing mode.
4	URAIRQ_SHAR	R/W	0 : IRQ is not sharing with other device. 1 : IRQ is sharing with other device.

F81218

3:0	SELURAIRQ[3:0]	R/W	<p>In LPC mode , select the Serial IRQ channel.</p> <p>In ISA mode , select one of six IRQ pins .</p> <p>03h : use serial IRQ channel 3 in LPC mode or use ISA_IRQA in ISA mode.</p> <p>04h : use serial IRQ channel 4 in LPC mode or use ISA_IRQB in ISA mode.</p> <p>05h : use serial IRQ channel 5 in LPC mode or use ISA_IRQC in ISA mode.</p> <p>09h : use serial IRQ channel 9 in LPC mode or use ISA_IRQD in ISA mode.</p> <p>0Ah : use serial IRQ channel 10 in LPC mode or use ISA_IRQE in ISA mode.</p> <p>0Bh : use serial IRQ channel 11 in LPC mode or use ISA_IRQF in ISA mode.</p> <p>Otherwise will disable interrupt.</p>
-----	----------------	-----	--

6.2.5 UART 1 Clock Select Register – index F0h

Power-on default [7:0] = 0x00h.

Bit	Name	R/W	Description
7:5	Reserved	R/W	Return 0 when read.
4	RS485	R/W	<p>0: The RTS# is controlled by programming MCR[1]. (offset +4)</p> <p>1: The RTS# is drive high when transmitting data and sink low when receiving data.</p>
3	RXW4C_IRA	R/W	<p>0 : No reception delay when SIR is changed from TX to RX.</p> <p>1 : Reception delay 4 character-time when SIR is changed from TX to RX.</p>
2	TXW4C_IRA	R/W	<p>0 : No transmission delay when SIR is changed from RX to TX.</p> <p>1 : Transmission delay 4 character-time when SIR is changed from RX to TX.</p>
1:0	SELURCLK1 SELURCLK0	R/W	<p>00 : UART 1 clock source is 1.8462MHz (24MHz/13)</p> <p>01/10/11 selection reserved.</p>

6.2.6 IR1 Control Register – index F1h

Power-on default [7:0] = 0x44h.

Bit	Name	R/W	Description
7:5	Reserved	R/W	Return 010b when read.
4:3	IRA_MODE1 IRA_MODE0	R/W	0X: Disable IR1 function. 10 : Enable IR1 function, active pulse is 1.6uS. 11 : Enable IR1 function, active pulse is 3/16 bit time.
2	Half_Full_Duplex	R/W	0 : Full Duplex function for IR self test. 1 : Half Duplex function. Return 1 when read.
1	TXINV_IRA	R/W	0 : IRTX1 is not inverted. 1 : Inverse the IRTX1.
0	RXINV_IRA	R/W	0 : IRRX1 is not inverted. 1 : Inverse the IRRX1.

6.3 UART 2 Device Control Register (LDN 1)

6.3.1 Device Enable Register – index 30h

Power-on default [7:0] = 0x01h when SOUT2/PS_2F8_IRQB or DTR2#/PS_2E0_IRQB is pull-up, else 0x00h.

Bit	Name	R/W	Description
7:1	Reserved	R/W	Return 0 when read.
0	URB_EN	R/W	0 : Disable UART 2. 1 : Enable UART 2.

6.3.2 I/O Port Select Register – index 60h

Power-on default [7:0] = 0x02h when SOUT2/PS_2F8_IRQB or DTR2#/PS_2E0_IRQB is pullup, else 0x00h.

Bit	Name	R/W	Description
7:0	URB_BASE[15:8]	R/W	UART 2 I/O Port Address high byte.

F81218

6.3.3 I/O Port Select Register – index 61h

Power-on default [7:0] = 0xF8h when SOUT2/PS_2F8_IRQB is pull-up,
0xE0h when DTR2#/PS_2E0_IRQB is pull-up, else 0x00h.

Bit	Name	R/W	Description
7:0	URB_BASE[7:0]	R/W	UART 2 I/O Port Address low byte.

6.3.4 IRQ Channel Select Register – index 70h

Power-on default [7:0] = 0x03h when SOUT2/PS_2F8_IRQB or DTR2#/PS_2E0_IRQB is pull-up,
else 0x00h

Bit	Name	R/W	Description
7:6	Reserved	R/W	Return 0 when read.
5	URBIRQ_MODE	R/W	0 : PCI IRQ sharing mode. 1 : ISA IRQ sharing mode. This bit is effective in IRQ sharing mode.
4	URBIRQ_SHAR	R/W	0 : IRQ is not sharing with other device. 1 : IRQ is sharing with other device.
3:0	SELURAIRQ[3:0]	R/W	In LPC mode , select the Serial IRQ channel. In ISA mode , select one of six IRQ pins . 03h : use serial IRQ channel 3 in LPC mode or use ISA_IRQA in ISA mode. 04h : use serial IRQ channel 4 in LPC mode or use ISA_IRQB in ISA mode. 05h : use serial IRQ channel 5 in LPC mode or use ISA_IRQC in ISA mode. 09h : use serial IRQ channel 9 in LPC mode or use ISA_IRQD in ISA mode. 0Ah : use serial IRQ channel 10 in LPC mode or use ISA_IRQE in ISA mode. 0Bh : use serial IRQ channel 11 in LPC mode or use ISA_IRQF in ISA mode. Otherwise will disable interrupt.

6.3.5 UART 2 Clock Select Register – index F0h

Power-on default [7:0] = 0x00h.

Bit	Name	R/W	Description
7:5	Reserved	R/W	Return 0 when read.
4	RS485	R/W	0: The RTS# is controlled by programming MCR[1]. (offset +4) 1: The RTS# is drive high when transmitting data and sink low when receiving data.
3	RXW4C_IRB	R/W	0 : No reception delay when SIR is changed from TX to RX. 1 : Reception delay 4 character-time when SIR is changed from TX to RX.
2	TXW4C_IRB	R/W	0 : No transmission delay when SIR is changed from RX to TX. 1 : Transmission delay 4 character-time when SIR is changed from RX to TX.
1:0	SELURACKL1 SELURACKL0	R/W	00 : UART 2 clock source is 1.8462MHz (24MHz/13) 01/10/11 selection reserved.

6.3.6 IR 2 Control Register – index F1h

Power-on default [7:0] = 0x44h.

Bit	Name	R/W	Description
7:5	Reserved	R/W	Return 010b when read.
4:3	IRB_MODE1 IRB_MODE0	R/W	0X: Disable IR2 function. 10 : Enable IR2 function, active pulse is 1.6uS. 11 : Enable IR2 function, active pulse is 3/16 bit time.
2	Half_Full_Duplex	R/W	0 : Full Duplex function for IR self test. 1 : Half Duplex function. Return 1 when read.
1	TXINV_IRB	R/W	0 : IRTX2 is not inverted. 1 : Inverse the IRTX2.
0	RXINV_IRB	R/W	0 : IRRX2 is not inverted. 1 : Inverse the IRRX2.

6.4 UART 3 Device Control Register (LDN 2)

6.4.1 Device Enable Register – index 30h

Power-on default [7:0] = 0x01h when SOUT3/PS_3E8_IRQC is pull-up, else 0x00h.

Bit	Name	R/W	Description
7:1	Reserved	R/W	Return 0 when read.
0	URC_EN	R/W	0 : Disable UART 3. 1 : Enable UART 3.

6.4.2 I/O Port Select Register – index 60h

Power-on default [7:0] = 0x03h when SOUT3/PS_3E8_IRQC is pull-up, else 0x00h.

Bit	Name	R/W	Description
7:0	URC_BASE[15:8]	R/W	UART 3 I/O Port Address high byte.

6.4.3 I/O Port Select Register – index 61h

Power-on default [7:0] = E8h when SOUT3/PS_3E8_IRQC is pull-up, else 0x00h.

Bit	Name	R/W	Description
7:0	URC_BASE[7:0]	R/W	UART 3 I/O Port Address low byte.

6.4.4 IRQ Channel Select Register – index 70h

Power-on default [7:0] = 0x05h when SOUT3/PS_3E8_IRQC is pull-up, else 0x00h.

Bit	Name	R/W	Description
7:6	Reserved	R/W	Return 0 when read.
5	URCIRQ_MODE	R/W	0 : PCI IRQ sharing mode. 1 : ISA IRQ sharing mode. This bit is effective in IRQ sharing mode.
4	URCIRQ_SHAR	R/W	0 : IRQ is not sharing with other device.

F81218

			1 : IRQ is sharing with other device.
3:0	SELURCIRQ[3:0]	R/W	<p>In LPC mode , select the Serial IRQ channel.</p> <p>In ISA mode , select one of six IRQ pins .</p> <p>03h : use serial IRQ channel 3 in LPC mode or use ISA_IRQA in ISA mode.</p> <p>04h : use serial IRQ channel 4 in LPC mode or use ISA_IRQB in ISA mode.</p> <p>05h : use serial IRQ channel 5 in LPC mode or use ISA_IRQC in ISA mode.</p> <p>09h : use serial IRQ channel 9 in LPC mode or use ISA_IRQD in ISA mode.</p> <p>0Ah : use serial IRQ channel 10 in LPC mode or use ISA_IRQE in ISA mode.</p> <p>0Bh : use serial IRQ channel 11 in LPC mode or use ISA_IRQF in ISA mode.</p> <p>Otherwise will disable the interrupt.</p>

6.4.5 UART 3 Clock Select Register – index F0h

Power-on default [7:0] = 0000_0000b.

Bit	Name	R/W	Description
7:5	Reserved	R/W	Return 0 when read.
4	RS485	R/W	<p>0: The RTS# is controlled by programming MCR[1]. (offset +4)</p> <p>1: The RTS# is drive high when transmitting data and sink low when receiving data.</p>
3:2	Reserved	R/W	Return 0 when read.
1:0	SELURCCLK1 SELURCCLK0	R/W	<p>00 : UART 3 clock source is 1.8462MHz (24MHz/13)</p> <p>01/10/11 selection reserved.</p>

6.5 UART 4 Device Control Register (LDN 3)

6.5.1 Device Enable Register – index 30h

Power-on default [7:0] = 0x01h when SOUT4/PS_2E8_IRQD is pull-up, else 0x00h.

Bit	Name	R/W	Description
-----	------	-----	-------------

F81218

7:1	Reserved	R/W	Return 0 when read.
0	URD_EN	R/W	0 : Disable UART 4. 1 : Enable UART 4.

6.5.2 I/O Port Select Register – index 60h

Power-on default [7:0] = 0x02h when SOUT4/PS_2E8_IRQD is pull-up, else 0x00h.

Bit	Name	R/W	Description
7:0	URD_BASE[15:8]	R/W	UART 4 I/O Port Address high byte.

6.5.3 I/O Port Select Register – index 61h

Power-on default [7:0] = 0xE8h when SOUT4/PS_2E8_IRQD is pull-up, else 0x00h.

Bit	Name	R/W	Description
7:0	URD_BASE[7:0]	R/W	UART 4 I/O Port Address low byte.

6.5.4 IRQ Channel Select Register – index 70h

Power-on default [7:0] = 0x09h when SOUT4/PS_2E8_IRQD is pull-up, else 0x00h.

Bit	Name	R/W	Description
7:6	Reserved	R/W	Return 0 when read.
5	URDIRQ_MODE	R/W	0 : PCI IRQ sharing mode 1 : ISA IRQ sharing mode. This bit is effective in IRQ sharing mode.
4	URDIRQ_SHAR	R/W	0 : IRQ is not sharing with other device. 1 : IRQ is sharing with other device.
3:0	SELURDIRQ[3:0]	R/W	In LPC mode , select the Serial IRQ channel. In ISA mode , select one of six IRQ pins . 03h : use serial IRQ channel 3 in LPC mode or use ISA_IRQA in ISA mode. 04h : use serial IRQ channel 4 in LPC mode or use ISA_IRQB in ISA mode. 05h : use serial IRQ channel 5 in LPC mode or use ISA_IRQC in ISA mode. 09h : use serial IRQ channel 9 in LPC mode or use ISA_IRQD in ISA mode.

F81218

			0Ah : use serial IRQ channel 10 in LPC mode or use ISA_IRQE in ISA mode. 0Bh : use serial IRQ channel 11 in LPC mode or use ISA_IRQF in ISA mode. Otherwise will disable the interrupt.
--	--	--	---

6.5.5 UART 4 Clock Select Register – index F0h

Power-on default [7:0] = 0x00h.

Bit	Name	R/W	Description
7:5	Reserved	R/W	Return 0 when read.
4	RS485	R/W	0: The RTS# is controlled by programming MCR[1]. (offset +4) 1: The RTS# is drive high when transmitting data and sink low when receiving data.
3:2	Reserved	R/W	Return 0 when read.
1:0	SELURCCLK1 SELURCCLK0	R/W	00 : UART 3 clock source is 1.8462MHz (24MHz/13) 01/10/11 selection reserved.

6.6 UART 5 Device Control Register (LDN 4)

6.6.1 Device Enable Register – index 30h

Power-on default [7:0] = 0x01h when SOUT5/PS_338_IRQE is pull-up, else 0x00h.

Bit	Name	R/W	Description
7:1	Reserved	R/W	Return 0 when read.
0	URE_EN	R/W	0 : Disable UART 5. 1 : Enable UART 5.

6.6.2 I/O Port Select Register – index 60h

Power-on default [7:0] = 0x03h when SOUT5/PS_338_IRQE is pull-up, else 0x00h.

Bit	Name	R/W	Description
7:0	URE_BASE[15:8]	R/W	UART 5 I/O Port Address high byte.

6.6.3 I/O Port Select Register – index 61h

Power-on default [7:0] = 0x38h when SOUT5/PS_338_IRQE is pull-up, else 0x00h.

Bit	Name	R/W	Description
7:0	URE_BASE[7:0]	R/W	UART 5 I/O Port Address low byte.

6.6.5 IRQ Channel Select Register – index 70h

Power-on default [7:0] = 0x0Ah when SOUT5/PS_338_IRQE is pull-up, else 0x00h.

Bit	Name	R/W	Description
7:6	Reserved	R/W	Return 0 when read.
5	UREIRQ_MODE	R/W	0 : PCI IRQ sharing mode. 1 : ISA IRQ sharing mode. This bit is effective in IRQ sharing mode.
4	UREIRQ_SHAR	R/W	0 : IRQ is not sharing with other device. 1 : IRQ is sharing with other device.
3:0	SELUREIRQ[3:0]	R/W	In LPC mode , select the Serial IRQ channel. In ISA mode , select one of six IRQ pins . 03h : use serial IRQ channel 3 in LPC mode or use ISA_IRQA in ISA mode. 04h : use serial IRQ channel 4 in LPC mode or use ISA_IRQB in ISA mode. 05h : use serial IRQ channel 5 in LPC mode or use ISA_IRQC in ISA mode. 09h : use serial IRQ channel 9 in LPC mode or use ISA_IRQD in ISA mode. 0Ah : use serial IRQ channel 10 in LPC mode or use ISA_IRQE in ISA mode. 0Bh : use serial IRQ channel 11 in LPC mode or use ISA_IRQF in ISA mode. Otherwise will disable the interrupt.

6.6.6 UART 5 Clock Select Register – index F0h

Power-on default [7:0] = 0000_0000b.

Bit	Name	R/W	Description
7:5	Reserved	R/W	Return 0 when read.
4	RS485	R/W	0: The RTS# is controlled by programming MCR[1]. (offset +4) 1: The RTS# is drive high when transmitting data and sink low when receiving data.
3:2	Reserved	R/W	Return 0 when read.
1:0	SELURCCLK1 SELURCCLK0	R/W	00 : UART 3 clock source is 1.8462MHz (24MHz/13) 01/10/11 selection reserved.

6.7 UART 6 Device Control Register (LDN 5)

6.7.1 Device Enable Register – index 30h

Power-on default [7:0] = 0x01h when SOUT6/PS_238_IRQF is pull-up, else 0x00h.

Bit	Name	R/W	Description
7:1	Reserved	R/W	Return 0 when read.
0	URF_EN	R/W	0 : Disable UART 6. 1 : Enable UART 6.

6.7.2 I/O Port Select Register – index 60h

Power-on default [7:0] = 0x02h when SOUT6/PS_238_IRQF is pull-up, else 0x0h.

Bit	Name	R/W	Description
7:0	URF_BASE[15:8]	R/W	UART 6 I/O Port Address high byte.

6.7.3 I/O Port Select Register – index 61h

Power-on default [7:0] = 0x38h when SOUT6/PS_238_IRQF is pull-up, else 0x00h.

Bit	Name	R/W	Description
7:0	URF_BASE[7:0]	R/W	UART 6 I/O Port Address low byte.

6.7.4 IRQ Channel Select Register – index 70h

Power-on default [7:0] = 0x0Bh when SOUT6/PS_238_IRQF is pull-up, else 0x00h.

Bit	Name	R/W	Description
7:6	Reserved	R/W	Return 0 when read.
5	URFIRQ_MODE	R/W	0 : PCI IRQ sharing mode. 1 : ISA IRQ sharing mode. This bit is effective in IRQ sharing mode.
4	URFIRQ_SHAR	R/W	0 : IRQ is not sharing with other device. 1 : IRQ is sharing with other device.
3:0	SELURFIRQ[3:0]	R/W	In LPC mode , select the Serial IRQ channel. In ISA mode , select one of six IRQ pins . 03h : use serial IRQ channel 3 in LPC mode or use ISA_IRQA in ISA mode. 04h : use serial IRQ channel 4 in LPC mode or use ISA_IRQB in ISA mode. 05h : use serial IRQ channel 5 in LPC mode or use ISA_IRQC in ISA mode. 09h : use serial IRQ channel 9 in LPC mode or use ISA_IRQD in ISA mode. 0Ah : use serial IRQ channel 10 in LPC mode or use ISA_IRQE in ISA mode. 0Bh : use serial IRQ channel 11 in LPC mode or use ISA_IRQF in ISA mode. Otherwise will disable the interrupt.

6.7.5 UART 6 Clock Select Register – index F0h

Power-on default [7:0] = 0x00h.

Bit	Name	R/W	Description
7:5	Reserved	R/W	Return 0 when read.
4	RS485	R/W	0: The RTS# is controlled by programming MCR[1]. (offset +4) 1: The RTS# is drive high when transmitting data and sink low when receiving data.
3:2	Reserved	R/W	Return 0 when read.

F81218

1:0	SELURCCLK1 SELURCCLK0	R/W	00 : UART 3 clock source is 1.8462MHz (24MHz/13) 01/10/11 selection reserved.
-----	--------------------------	-----	--

6.8 Address Decoder 0 Device Control Register (LDN 6)

6.8.1 Device Enable Register – index 30h

Power-on default [7:0] = 0x00h.

Bit	Name	R/W	Description
7:1	Reserved	R/W	Return 0 when read.
0	ADDEC0_EN	R/W	0 : Disable Address Decoder 0. 1 : Enable Address Decoder 0.

6.8.2 Address Decoder Select Register 0– index 60h

Power-on default [7:0] = 0x00h.

Bit	Name	R/W	Description
7:0	DEC0_BASE[15:8]	R/W	Address high byte for ADD_DEC0/LPC_DEC0 .

6.8.3 Address Decoder Select Register 1– index 61h

Power-on default [7:0] = 0x00h.

Bit	Name	R/W	Description
7:0	DEC0_BASE[7:0]	R/W	Address low byte for ADD_DEC0/LPC_DEC0.

6.8.4 Address Mask Register – index 62h

Power-on default [7:0] = 0x00h

Bit	Name	R/W	Description
7:3	Reserved	R/W	Return 0 when read.
2:0	DEC0_SEL[2:0]	R/W	000 : Decode all 16 bits . 001 : Decode bit 15:1 010 : Decode bit 15:2 011 : Decode bit 15:3 100 : Decode bit 15:4

6.8.5 IRQIN0 Channel Select Register (Only for LPC) – index 70h

Power-on default [7:0] = 0x00h.

Bit	Name	R/W	Description
7:6	Reserved	R/W	Return 0 when read.
5	IRQIN0_MODE	R/W	0 : PCI IRQ sharing mode. 1 : ISA IRQ sharing mode. This bit is effective in IRQ sharing mode.
4	IRQIN0_SHAR	R/W	0 : IRQ is not sharing with other device. 1 : IRQ is sharing with other device.
3:0	SELRQIN0[3:0]	R/W	In LPC mode , select the Serial IRQ channel. 03h : use serial IRQ channel 3 in LPC mode. 04h : use serial IRQ channel 4 in LPC mode. 05h : use serial IRQ channel 5 in LPC mode. 09h : use serial IRQ channel 9 in LPC mode. 0Ah : use serial IRQ channel 10 in LPC mode. 0Bh : use serial IRQ channel 11 in LPC mode. Otherwise will disable the interrupt.

6.9 Address Decoder 1 Device Control Register (LDN 7)

6.9.1 Device Enable Register – index 30h

Power-on default [7:0] = 0x00h.

Bit	Name	R/W	Description
7:1	Reserved	R/W	Return 0 when read.
0	ADDEC1_EN	R/W	0 : Disable Address Decoder 1. 1 : Enable Address Decoder 1.

6.9.2 Address Decoder Select Register 0 – index 60h

Power-on default [7:0] = 0x00h.

F81218

Bit	Name	R/W	Description
7:0	DEC1_BASE[15:8]	R/W	Address high byte for ADD_DEC1/LPC_DEC1 .

6.9.3 Address Decoder Select Register 1 – index 61h

Power-on default [7:0] = 0x00h.

Bit	Name	R/W	Description
7:0	DEC1_BASE[7:0]	R/W	Address low byte for ADD_DEC1/LPC_DEC1.

6.9.4 Address Mask Register – index 62h

Power-on default [7:0] = 0x00h.

Bit	Name	R/W	Description
7:3	Reserved	R/W	Return 0 when read.
2:0	DEC1_SEL[2:0]	R/W	000 : Decode all 16 bits . 001 : Decode bit 15:1 010 : Decode bit 15:2 011 : Decode bit 15:3 100 : Decode bit 15:4

6.9.5 IRQIN1 Channel Select Register (Only for LPC) – index 70h

Power-on default [7:0] = 0x00h.

Bit	Name	R/W	Description
7:6	Reserved	R/W	Return 0 when read.
5	IRQIN1_MODE	R/W	0 : PCI IRQ sharing mode. 1 : ISA IRQ sharing mode. This bit is effective in IRQ sharing mode.
4	IRQIN1_SHAR	R/W	0 : IRQ is not sharing with other device. 1 : IRQ is sharing with other device.
3:0	SELIRQIN1[3:0]	R/W	In LPC mode , select the Serial IRQ channel.

F81218

			In ISA mode , select one of six IRQ pins . 03h : use serial IRQ channel 3 in LPC mode. 04h : use serial IRQ channel 4 in LPC mode. 05h : use serial IRQ channel 5 in LPC mode. 09h : use serial IRQ channel 9 in LPC mode. 0Ah : use serial IRQ channel 10 in LPC mode. 0Bh : use serial IRQ channel 11 in LPC mode. Otherwise will disable the interrupt.
--	--	--	---

6.10 Watch Dog Timer Device Control Register (LDN 8)

6.10.1 Device Enable Register – index 30h

Power-on default [7:0] = 0x01h when DTR3#/PS_WDT is pull-up, else 0x00h.

Bit	Name	R/W	Description
7:1	Reserved	R/W	Return 0 when read.
0	WDT_EN	R/W	0 : Disable Watchdog Timer. 1 : Enable Watchdog Timer.

6.10.2 I/O Port Select Register – index 60h

Power-on default [7:0] = 0x04h when DTR3#/PS_WDT is pull-up, else 0x00h.

Bit	Name	R/W	Description
7:0	WDT_BASE[15:8]	R/W	I/O Base high byte.

6.10.3 I/O Port Select Register – index 61h

Power-on default [7:0] = 0x42h when DTR3#/PS_WDT is pull-up, else 0x00h.

Bit	Name	R/W	Description
7:0	WDT_BASE[7:0]	R/W	I/O Base low byte.

6.10.4 IRQ Channel Select Register – index 70h

Power-on default [7:0] = 0x00h.

F81218

Bit	Name	R/W	Description
7:5	Reserved	R/W	Return 0 when read.
4	WDTIRQ_EN	R/W	0 : Time out is asserted only via WDT_OUT#. 1 : Time out is asserted via IRQ and WDT_OUT#.
3:0	SELWDTIRQ[3:0]	R/W	In LPC mode , select the Serial IRQ channel. In ISA mode , select one of six IRQ pins . 03h : use serial IRQ channel 3 in LPC mode or use ISA_IRQA in ISA mode. 04h : use serial IRQ channel 4 in LPC mode or use ISA_IRQB in ISA mode. 05h : use serial IRQ channel 5 in LPC mode or use ISA_IRQC in ISA mode. 09h : use serial IRQ channel 9 in LPC mode or use ISA_IRQD in ISA mode. 0Ah : use serial IRQ channel 10 in LPC mode or use ISA_IRQE in ISA mode. 0Bh : use serial IRQ channel 11 in LPC mode or use ISA_IRQF in ISA mode. Otherwise will disable the interrupt.

6.10.5 Timer Status and Control Register – index F0h

Power-on default [7:0] = 0x02h when DTR3#/PS_WDT is pull-up , else 0x00h.

Bit	Name	R/W	Description
7:3	Reserved	R/W	Return 0 when read.
2:1	WDT_UNIT[1:0]	R/W	00 : Timer Unit is 10ms. 01 : Timer Unit is 1 second 10 : Timer Unit is 1 minute. 11 : reserved.
0	WDT_EVENT	R/W	When read 0 : no time out occur. 1 : time out has occurred. when write 0 : no action 1 : clear the time out status.

6.10.6 Timer Count Number Register – index F1h

Power-on default [7:0] = 0x0Ah when DTR3#/PS_WDT is pull-up, else 0x00h.

Bit	Name	R/W	Description
7:0	WDT_CNT[7:0]	R/W	The number of count for watchdog timer. Write the same value twice to enable the timer, otherwise will disable timer.

6.11 GPIO and PME Device Control Register (LDN 9)

6.11.1 GPIO Port 2 Control Register – index F0h

Power-on default [7:0] = 0x00h.

Bit	Name	R/W	Description
7	GP27_OE	R/W	0 : GP27 is in input mode. 1 : GP27 is in output mode.
6	GP26_OE	R/W	0 : GP26 is in input mode. 1 : GP26 is in output mode.
5	GP25_OE	R/W	0 : GP25 is in input mode. 1 : GP25 is in output mode.
4	GP24_OE	R/W	0 : GP24 is in input mode. 1 : GP24 is in output mode.
3	GP23_OE	R/W	0 : GP23 is in input mode. 1 : GP23 is in output mode.
2	GP22_OE	R/W	0 : GP22 is in input mode. 1 : GP22 is in output mode.
1	GP21_OE	R/W	0 : GP21 is in input mode. 1 : GP21 is in output mode.
0	GP20_OE	R/W	0 : GP20 is in input mode. 1 : GP20 is in output mode.

6.11.2 GPIO Port 1 Control Register – index F1h

Power-on default [7:0] = 0x00h.

F81218

Bit	Name	R/W	Description
7	CLRGPOE_EN	R/W	0 : GP14, GP13, GP12, GP11, GP10 is in original mode when Watchdog timeout occurred. 1 : GP14, GP13, GP12, GP11, GP10 is reset to input mode when Watchdog timeout occurred.
6	GP16_OE	R/W	0 : GP16 is in input mode. 1 : GP16 is in output mode.
5	GP15_OE	R/W	0 : GP15 is in input mode. 1 : GP15 is in output mode.
4	GP14_OE	R/W	0 : GP14 is in input mode. 1 : GP14 is in output mode.
3	GP13_OE	R/W	0 : GP13 is in input mode. 1 : GP13 is in output mode.
2	GP12_OE	R/W	0 : GP12 is in input mode. 1 : GP12 is in output mode.
1	GP11_OE	R/W	0 : GP11 is in input mode. 1 : GP11 is in output mode.
0	GP10_OE	R/W	0 : GP10 is in input mode. 1 : GP10 is in output mode.

6.11.3 GPIO Port 2 Output Data Control Register – index F2h

Power-on default [7:0] = 0xFFh.

Bit	Name	R/W	Description
7	GP27_OUT	R/W	0 : GP27 is output low in output mode. 1 : GP27 is tri-state.
6	GP26_OUT	R/W	0 : GP26 is output low in output mode. 1 : GP26 is tri-state.
5	GP25_OUT	R/W	0 : GP25 is output low in output mode. 1 : GP25 is tri-state.
4	GP24_OUT	R/W	0 : GP24 is output low in output mode. 1 : GP24 is tri-state.
3	GP23_OUT	R/W	0 : GP23 is output low in output mode. 1 : GP23 is tri-state.
2	GP22_OUT	R/W	0 : GP22 is output low in output mode. 1 : GP22 is tri-state.

F81218

1	GP21_OUT	R/W	0 : GP21 is output low in output mode. 1 : GP21 is tri-state.
0	GP20_OUT	R/W	0 : GP20 is output low in output mode. 1 : GP20 is tri-state.

6.11.4 GPIO Port 1 Output Data Register – index F3h

Power-on default [7:0] = 0x7Fh.

Bit	Name	R/W	Description
7	Reserved	R/W	Return 0 when read.
6	GP16_OUT	R/W	0 : GP16 is output low in output mode. 1 : GP16 is tri-state.
5	GP15_OUT	R/W	0 : GP15 is output low in output mode. 1 : GP15 is tri-state.
4	GP14_OUT	R/W	0 : GP14 is output low in output mode. 1 : GP14 is tri-state.
3	GP13_OUT	R/W	0 : GP13 is output low in output mode. 1 : GP13 is tri-state.
2	GP12_OUT	R/W	0 : GP12 is output low in output mode. 1 : GP12 is tri-state.
1	GP11_OUT	R/W	0 : GP11 is output low in output mode. 1 : GP11 is tri-state.
0	GP10_OUT	R/W	0 : GP10 is output low in output mode. 1 : GP10 is tri-state.

6.11.5 PME Event 1 Control Register – index F4h

Power-on default [7:0] = 0x7Fh.

F81218

Bit	Name	R/W	Description
7	GPME27_EN	R/W	0 : disable PME via GP27 1 : enable PME via GP27.
6	GPME26_EN	R/W	0 : disable PME via GP26 1 : enable PME via GP26.
5	GPME25_EN	R/W	0 : disable PME via GP25 1 : enable PME via GP25.
4	GPME24_EN	R/W	0 : disable PME via GP24 1 : enable PME via GP24.
3	GPME23_EN	R/W	0 : disable PME via GP23 1 : enable PME via GP23.
2	GPME22_EN	R/W	0 : disable PME via GP22 1 : enable PME via GP22.
1	GPME21_EN	R/W	0 : disable PME via GP21 1 : enable PME via GP21.
0	GPME20_EN	R/W	0 : disable PME via GP20 1 : enable PME via GP20.

6.11.6 PME Event 2 Control Register – index F5h

Power-on default [7:0] = 0x7Fh.

Bit	Name	R/W	Description
7	Reserved	R/W	Return 0 when read.
6	GPME16_EN	R/W	0 : disable PME via GP16 1 : enable PME via GP16.
5	GPME15_EN	R/W	0 : disable PME via GP15 1 : enable PME via GP15.
4	GPME14_EN	R/W	0 : disable PME via GP14 1 : enable PME via GP14.
3	GPME13_EN	R/W	0 : disable PME via GP13 1 : enable PME via GP13.
2	GPME12_EN	R/W	0 : disable PME via GP12 1 : enable PME via GP12.
1	GPME11_EN	R/W	0 : disable PME via GP11 1 : enable PME via GP11.

F81218

0	GPME10_EN	R/W	0 : disable PME via GP10 1 : enable PME via GP10.
---	-----------	-----	--

6.11.7 PME Event 3 Control Register – index F6h

Power-on default [7:0] = 0x7Fh.

Bit	Name	R/W	Description
7:6	Reserved	R/W	Return 0 when read.
5	URFPME_EN	R/W	0 : disable PME via IRQ of UART 6 1 : enable PME via IRQ of UART 6.
4	UREPME_EN	R/W	0 : disable PME via IRQ of UART 5 1 : enable PME via IRQ of UART 5.
3	URDPME_EN	R/W	0 : disable PME via IRQ of UART 4 1 : enable PME via IRQ of UART 4.
2	URCPME_EN	R/W	0 : disable PME via IRQ of UART 3 1 : enable PME via IRQ of UART 3.
1	URBPME_EN	R/W	0 : disable PME via IRQ of UART 2 1 : enable PME via IRQ of UART 2.
0	URAPME_EN	R/W	0 : disable PME via IRQ of UART 1 1 : enable PME via IRQ of UART 1.

6.11.8 GPIO Port 2 Input Status Register – index F7h

Bit	Name	R/W	Description
7	GP27_ST	R/W	Status of GP27
6	GP26_ST	R/W	Status of GP26
5	GP25_ST	R/W	Status of GP25
4	GP24_ST	R/W	Status of GP24
3	GP23_ST	R/W	Status of GP23
2	GP22_ST	R/W	Status of GP22
1	GP21_ST	R/W	Status of GP21
0	GP20_ST	R/W	Status of GP20

6.11.9 GPIO Port 1 Input Status Register – index F8h

Bit	Name	R/W	Description
7	Reserved	R/W	Return 0 when read
6	GP16_ST	R/W	Status of GP16
5	GP15_ST	R/W	Status of GP15
4	GP14_ST	R/W	Status of GP14
3	GP13_ST	R/W	Status of GP13
2	GP12_ST	R/W	Status of GP12
1	GP11_ST	R/W	Status of GP11
0	GP10_ST	R/W	Status of GP10

6.11.10 PME Real Time Status Register – index F9h

Bit	Name	R/W	Description
7:6	Reserved	R/W	Return 0 when read
5	PME_ST_REAL3[5]	R/W	Status of UART 6 IRQ.
4	PME_ST_REAL3[4]	R/W	Status of UART 5 IRQ.
3	PME_ST_REAL3[3]	R/W	Status of UART 4 IRQ.
2	PME_ST_REAL3[2]	R/W	Status of UART 3 IRQ.
1	PME_ST_REAL3[1]	R/W	Status of UART 2 IRQ.
0	PME_ST_REAL3[0]	R/W	Status of UART 1 IRQ.

6.11.11 PME Edge Status 1 Register – index FAh

Power on default = 0x00h

Bit	Name	R/W	Description
7	PME_ST_EDGE1[7]	R/W	0 : No transition at GP27 1 : A high to low transition at GP27 in input mode.
6	PME_ST_EDGE1[6]	R/W	0 : No transition at GP26 1 : A high to low transition at GP26 in input mode.

F81218

5	PME_ST_EDGE1[5]	R/W	0 : No transition at GP25 1 : A high to low transition at GP25 in input mode.
4	PME_ST_EDGE1[4]	R/W	0 : No transition at GP24 1 : A high to low transition at GP24 in input mode.
3	PME_ST_EDGE1[3]	R/W	0 : No transition at GP23 1 : A high to low transition at GP23 in input mode.
2	PME_ST_EDGE1[2]	R/W	0 : No transition at GP22 1 : A high to low transition at GP22 in input mode.
1	PME_ST_EDGE1[1]	R/W	0 : No transition at GP21 1 : A high to low transition at GP21 in input mode.
0	PME_ST_EDGE1[0]	R/W	0 : No transition at GP20 1 : A high to low transition at GP20 in input mode.

6.11.12 PME Edge Status 2 Register – index FBh

Power on default = 0x00h

Bit	Name	R/W	Description
7	Reserved	R/W	Return 0 when read.
6	PME_ST_EDGE2[6]	R/W	0 : No transition at GP16 1 : A high to low transition at GP16 in input mode.
5	PME_ST_EDGE2[5]	R/W	0 : No transition at GP15 1 : A high to low transition at GP15 in input mode.
4	PME_ST_EDGE2[4]	R/W	0 : No transition at GP14 1 : A high to low transition at GP14 in input mode.
3	PME_ST_EDGE2[3]	R/W	0 : No transition at GP13 1 : A high to low transition at GP13 in input mode.
2	PME_ST_EDGE2[2]	R/W	0 : No transition at GP12 1 : A high to low transition at GP12 in input mode.
1	PME_ST_EDGE2[1]	R/W	0 : No transition at GP11 1 : A high to low transition at GP11 in input mode.
0	PME_ST_EDGE2[0]	R/W	0 : No transition at GP10 1 : A high to low transition at GP10 in input mode.

6.11.13 PME Edge Status 3 Register – index FCh

Power on default = 0x00h

F81218

Bit	Name	R/W	Description
7:6	Reserved	R/W	Return 0 when read.
5	PME_ST_EDGE3[5]	R/W	0 : No transition at UART 6 IRQ 1 : A low to high transition at UART 6 IRQ.
4	PME_ST_EDGE3[4]	R/W	0 : No transition at UART 5 IRQ 1 : A low to high transition at UART 5 IRQ.
3	PME_ST_EDGE3[3]	R/W	0 : No transition at UART 4 IRQ 1 : A low to high transition at UART 4 IRQ.
2	PME_ST_EDGE3[2]	R/W	0 : No transition at UART 3 IRQ 1 : A low to high transition at UART 3 IRQ.
1	PME_ST_EDGE3[1]	R/W	0 : No transition at UART 2 IRQ 1 : A low to high transition at UART 2 IRQ.
0	PME_ST_EDGE3[0]	R/W	0 : No transition at UART 1 IRQ 1 : A low to high transition at UART 1 IRQ.

Fintek Confidential
Do Not Copy!

7. Electron Characteristic

7.1 Absolute Maximum Ratings

PARAMETER	RATING	UNIT
Power Supply Voltage	-0.5 to 4.0	V
Input Voltage	-0.5 to 5.5	V
Operating Temperature	0 to +70	° C
Storage Temperature	-55 to +150	° C

Note: Exposure to conditions beyond those listed under Absolute Maximum Ratings may adversely affect the life and reliability of the device.

7.2 DC Characteristics

((Ta = 0° C to 70° C, VDD = 3.3V ± 10%, VSS = 0V)

PARAMETER	SYM.	MIN.	TYP.	MAX.	UNIT	CONDITIONS
I/O_{12t} - TTL level bi-directional pin with source-sink capability of 12 mA						
Input Low Voltage	VIL			0.8	V	
Input High Voltage	VIH	2.0			V	
Output Low Current	IOL	10	12		mA	VOL = 0.4V
Output High Current	IOH		-12	-10	mA	VOH = 2.4V
Input High Leakage	ILIH			+10	μA	VIN = VDD
Input Low Leakage	ILIL			-10	μA	VIN = 0V
I/O_{12ts} - TTL level bi-directional pin with source-sink capability of 12 mA and schmitt-trigger level input						
Input Low Threshold Voltage	Vt-	0.5	0.8	1.1	V	VDD = 3.3 V
Input High Threshold Voltage	Vt+	1.6	2.0	2.4	V	VDD = 3.3 V
Output Low Current	IOL	10	12		mA	VOL = 0.4 V
Output High Current	IOH		-12	-10	mA	VOH = 2.4V
Input High Leakage	ILIH			+10	μA	VIN = VDD
Input Low Leakage	ILIL			-10	μA	VIN = 0V

F81218

7.2 DC Characteristics, continued

PARAMETER	SYM.	MIN.	TYP.	MAX.	UNIT	CONDITIONS
OUT_{12t} - TTL level output pin with source-sink capability of 12 mA						
Output Low Current	IOL	12	16		mA	VOL = 0.4V
Output High Current	IOH		-14	-12	mA	VOH = 2.4V
OD₈ - Open-drain output pin with sink capability of 8 mA						
Output Low Current	IOL	6	8		mA	VOL = 0.4V
OD₁₆ - Open-drain output pin with sink capability of 16 mA						
Output Low Current	IOL	12	16		mA	VOL = 0.4V
I/OOD_{16ts} - TTL level bi-directional pin, can select to OD or OUT by register, with 16 mA source-sink capability						
Input Low Threshold Voltage	Vt-	0.5	0.8	1.1	V	VDD = 3.3 V
Input High Threshold Voltage	Vt+	1.6	2.0	2.4	V	VDD = 3.3 V
Output Low Current	IOL	6	8		mA	VOL = 0.4 V
Output High Current	IOH		-16	-12	mA	VOH = 2.4V
Input High Leakage	ILIH			+10	μA	VIN = VDD
Input Low Leakage	ILIL			-10	μA	VIN = 0V
IN_t - TTL level input pin						
Input Low Voltage	VIL			0.8	V	
Input High Voltage	VIH	2.0			V	
Input High Leakage	ILIH			+10	μA	VIN = VDD
Input Low Leakage	ILIL			-10	μA	VIN = 0 V
IN_{ts} - TTL level Schmitt-triggered input pin						
Input Low Threshold Voltage	Vt-	0.5	0.8	1.1	V	VDD = 3.3V
Input High Threshold Voltage	Vt+	1.6	2.0	2.4	V	VDD = 3.3V
Input High Leakage	ILIH			+10	μA	VIN = VDD
Input Low Leakage	ILIL			-10	μA	VIN = 0 V

F81218

7.3 AC Timing Characteristics

ISA Interface – IOR#

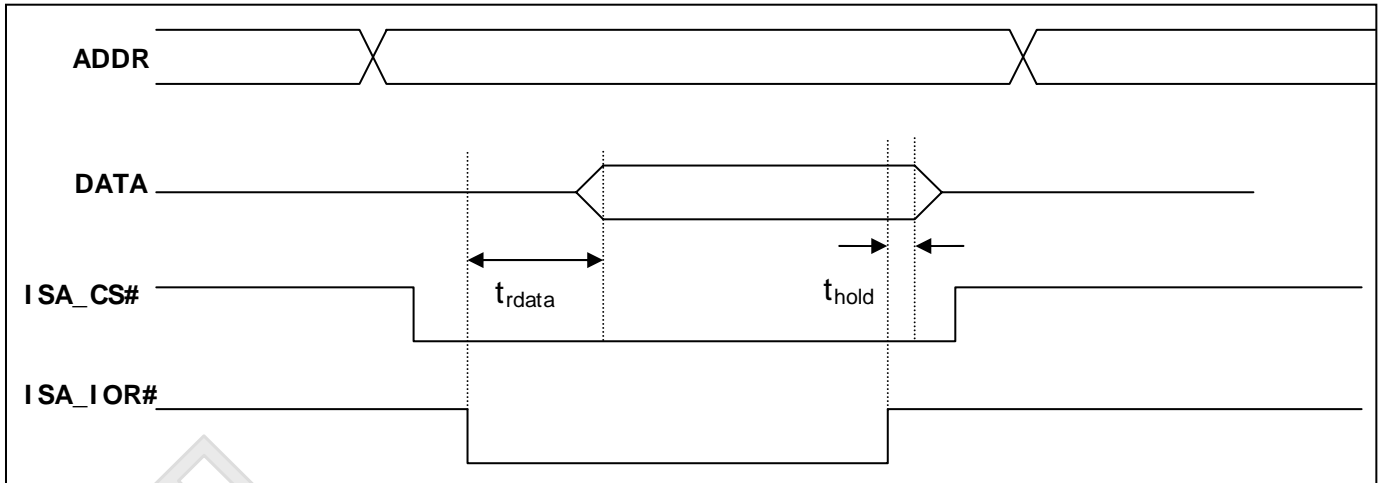

ISA Interface – IOW#

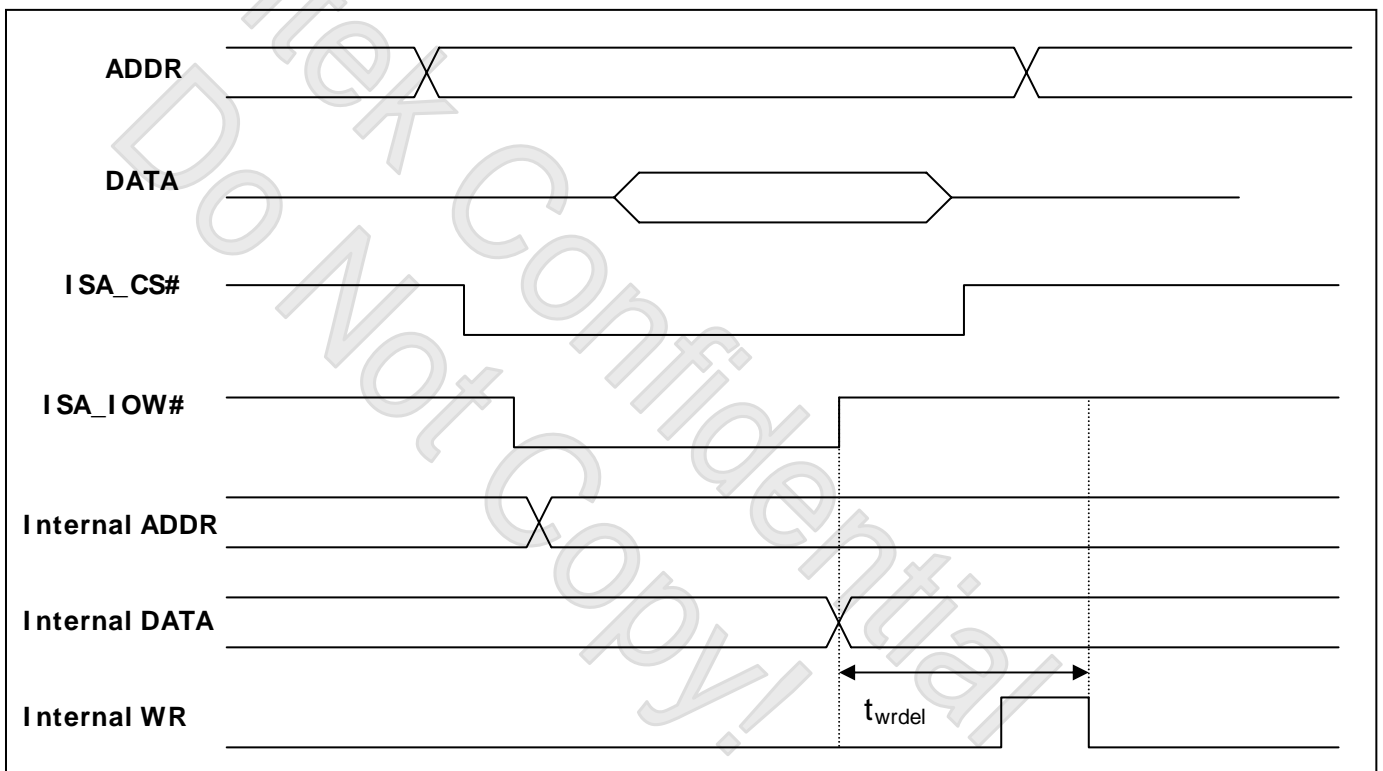

F81218

Recovery Time

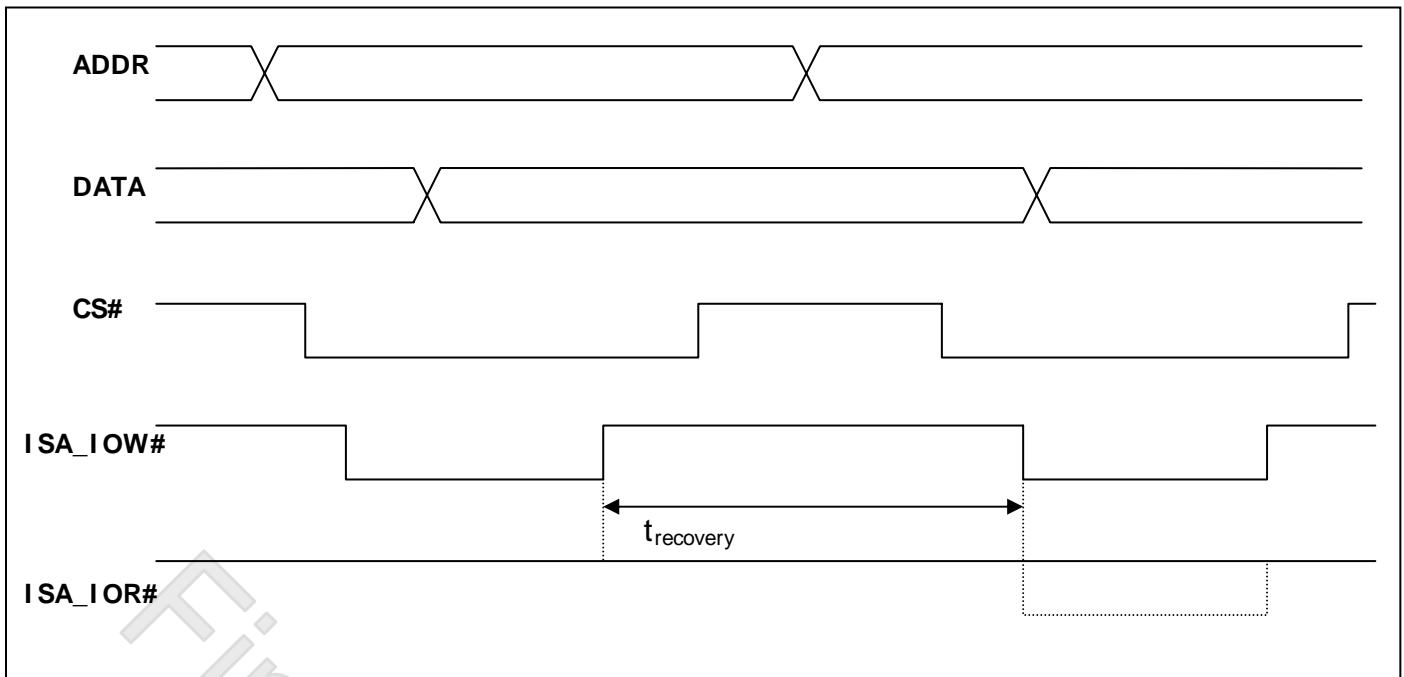

Name	Description	Min.	Typ.	Max.
t_{rdata}	The time from the IOR# falling edge to data valid.	52ns	-	124ns
t_{hold}	The time from the IOR# rising edge to data invalid.	2ns	-	52ns
t_{wrdel}	The time from the IOW# rising edge to the data written to registers.	84ns	-	126ns
t_{recovery}	The time from the end of IOW# to the next IOW# (or IOR#)	126ns	-	-

Note: In normal ISA W/R cycle, ISA_IOW# and ISA_IOR# are embraced in ISA_CS# as the wave forms show. When it is not the case, the reference point of the timing would be changed to the latest falling edge and the first rising edge.

8. Ordering Information

Part Number	Package Type	Production Flow
F81218D	100-LQFP (Normal)	Commercial, 0°C to +70°C
F81218DG	100-LQFP (Green Package)	Commercial, 0°C to +70°C

9. Package Dimensions

100pin-LQFP

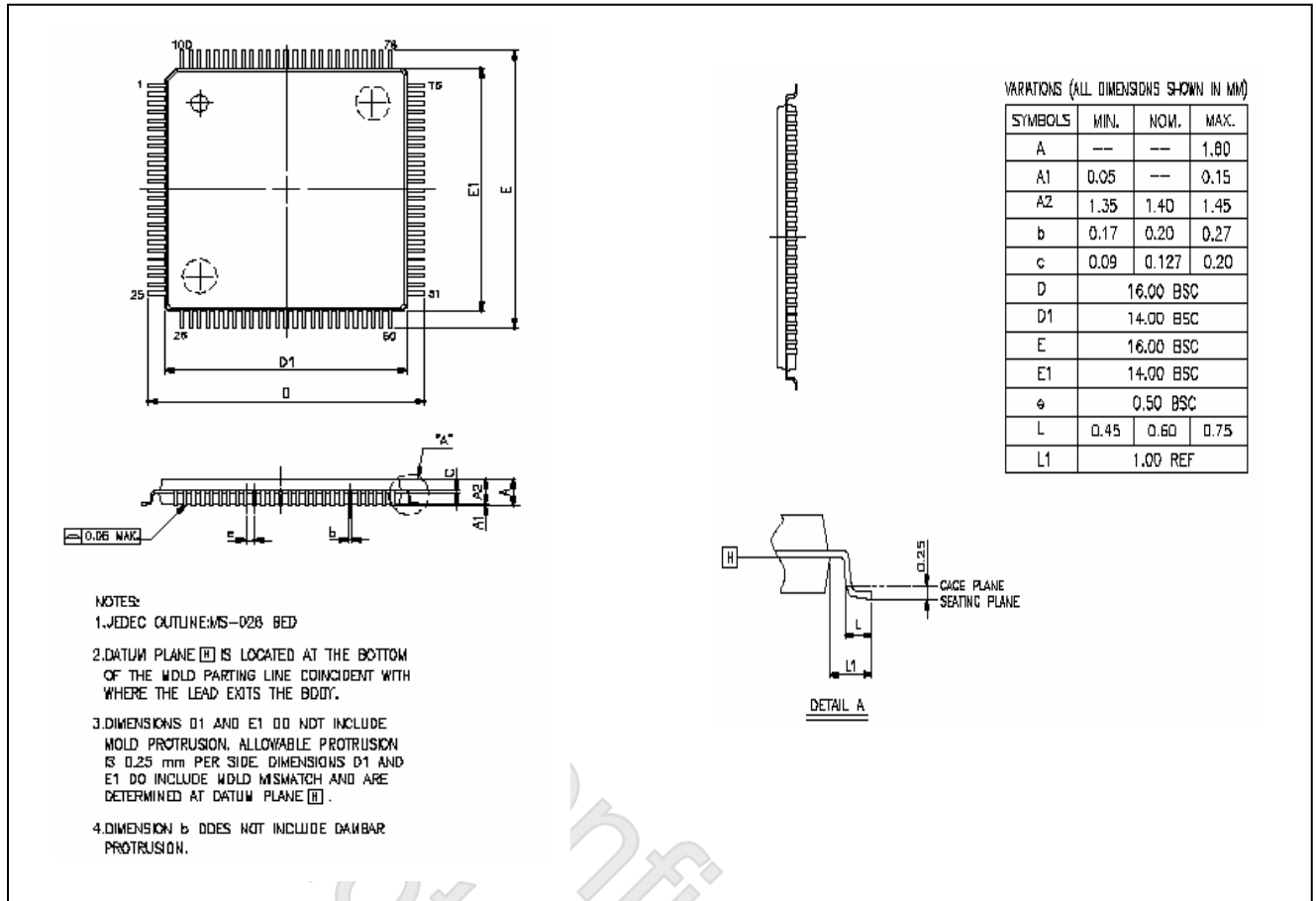

Headquarters

3F-7, No 36, Tai Yuan St.,

Chupei City, Hsinchu, Taiwan 302, R.O.C.

TEL : 886-3-5600168

FAX : 886-3-5600166

www: <http://www.fintek.com.tw>

Taipei Office

Bldg. K4, 7F, No.700, Chung Cheng Rd.,

Chungho City, Taipei, Taiwan 235, R.O.C.

TEL : 866-2-8227-8027

FAX : 866-2-8227-8037

Please note that all datasheet and specifications are subject to change without notice. All the trade marks of products and companies mentioned in this datasheet belong to their respective owner

F81218

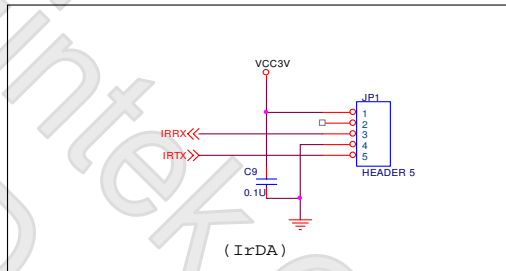
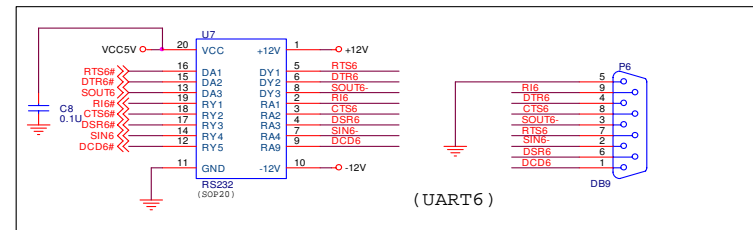
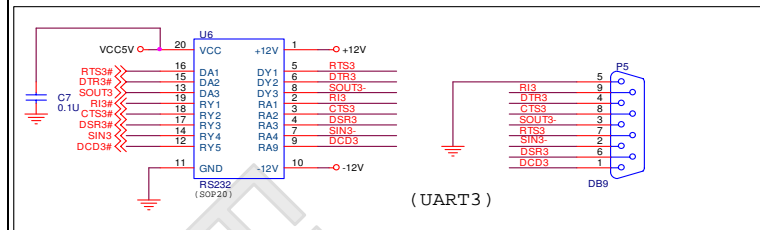
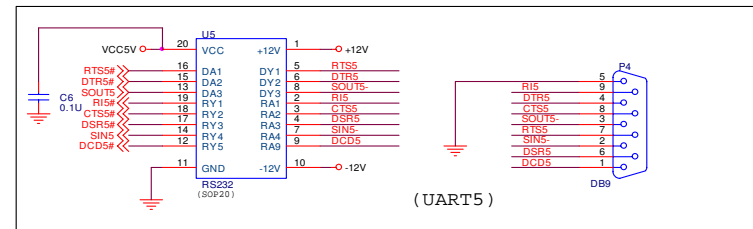
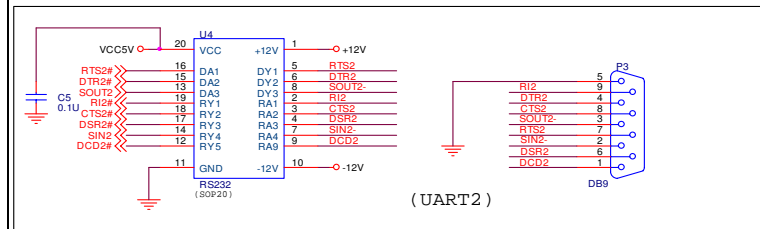
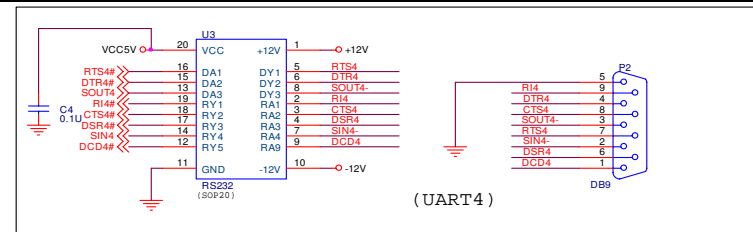
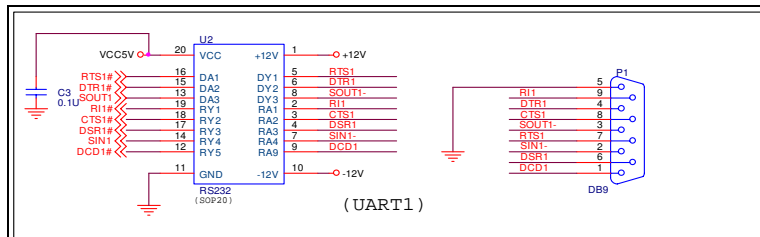

Title		
Feature Integration Technology Inc.		
Size	Document Number	Rev
8	UART and IrDA	0.2
Date:	Tuesday, September 16, 2003	Sheet 1 of 2

F81218

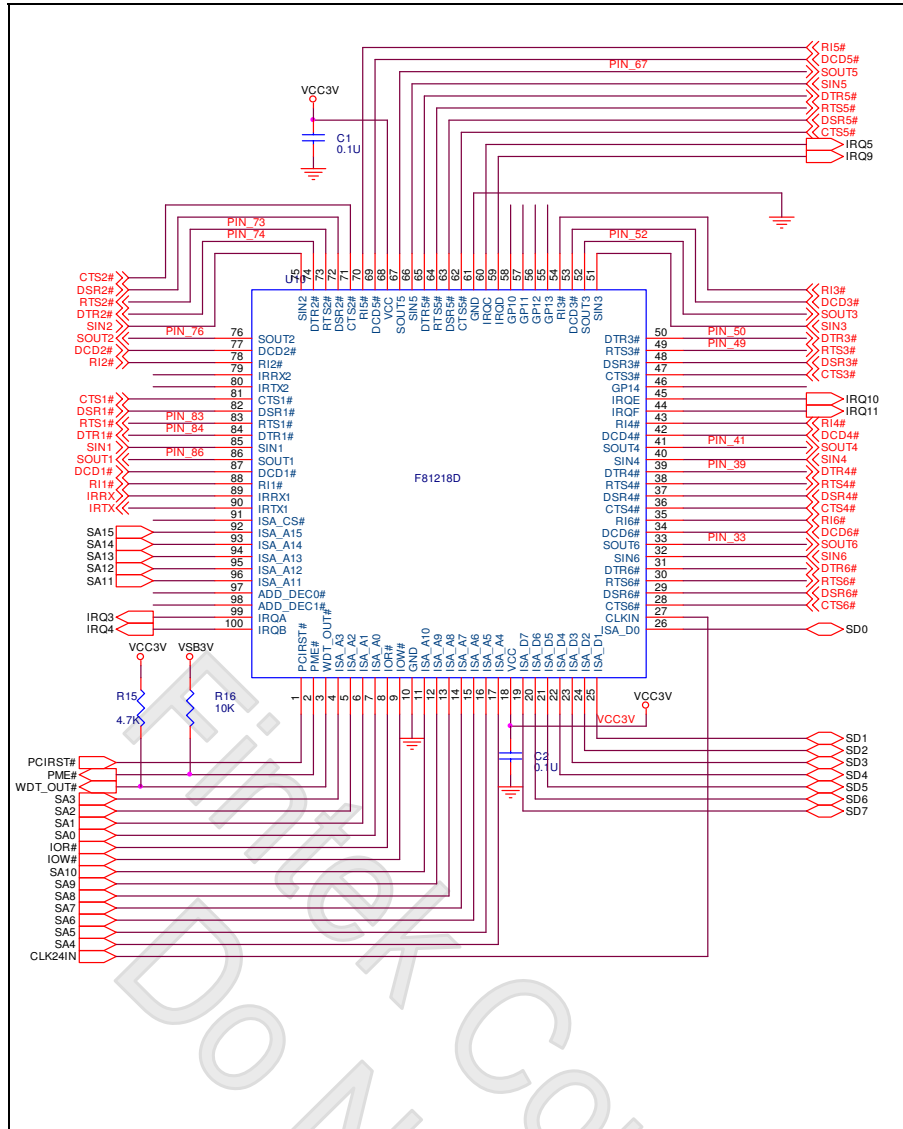

(Power On Setting Pin)

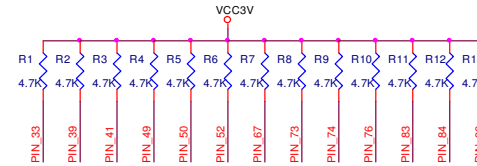

R1 on : UART 6 addr:0x238 IRQ11/F; off:UART 6 disabled.
 R7 on : UART 5 addr:0x338 IRQ10/E; off:UART 5 disabled.
 R3 on : UART 4 addr:0x2e8 IRQ9; off:UART 4 disabled.
 R6 on : UART 3 addr:0x3e8 IRQ5; off:UART 3 disabled.
 R10 on : UART 2 addr:0x2f8 irq4; R9 on and R10 off: UART 2 addr:0x2e0 IRQ4;
 R9 off and R10 off:UART 2 disabled.
 R13 on : UART 1 addr:0x3f8 irq3; R12 on and R13 off: UART 1 addr:0x3e0 IRQ3;
 R12 off and R13 off:UART 1 disabled.
 R5 on : Watch Dog Timer enabled and setting to 10 second when the clock input
 is 24Mhz. If the clock input is 48Mhz , the timer is setting to 5 second.
 off :disabled.
 R2 on:LPC interface; Off:ISA interface

R8	R4	R11	Address	Entry Key	On:1
0	0	0	0x4e/0x4f	0x77	Off:0
0	0	1	0x2e/0x2f	0x77	
0	1	0	0x4e/0x4f	0xa0	
0	1	1	0x2e/0x2f	0xa0	
1	0	0	0x4e/0x4f	0x87	
1	0	1	0x2e/0x2f	0x87	
1	1	0	0x4e/0x4f	0x67	
1	1	1	0x2e/0x2f	0x67	

Title		
Feature Integration Technology Inc.		
Size	Document Number	Rev
B	F81218D for ISA	0.2
Date:	Tuesday, January 06, 2004	Sheet 1 of 2

F81218

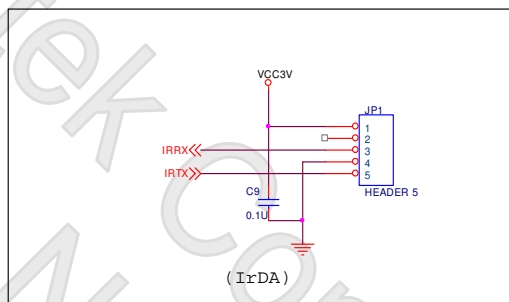
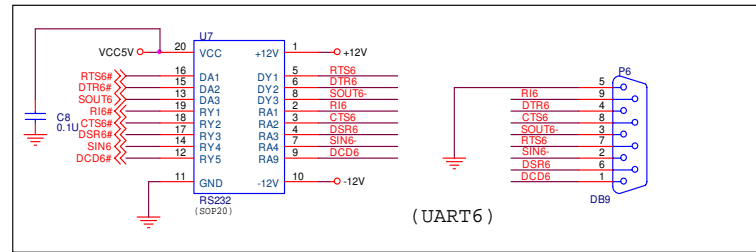
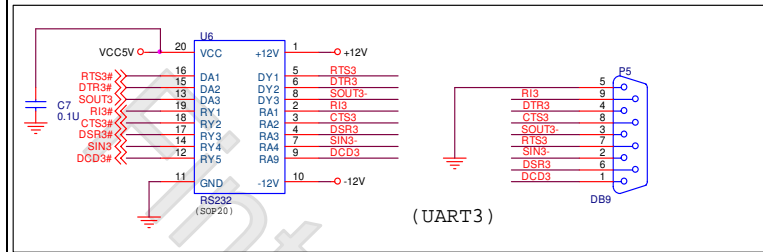
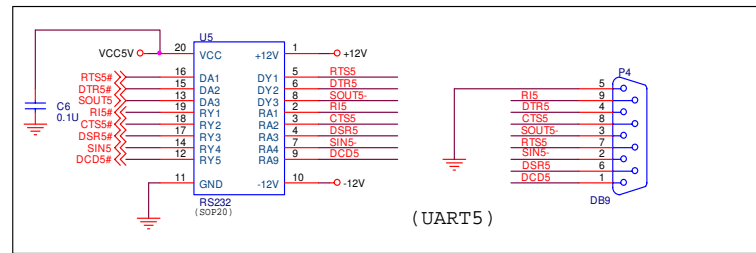
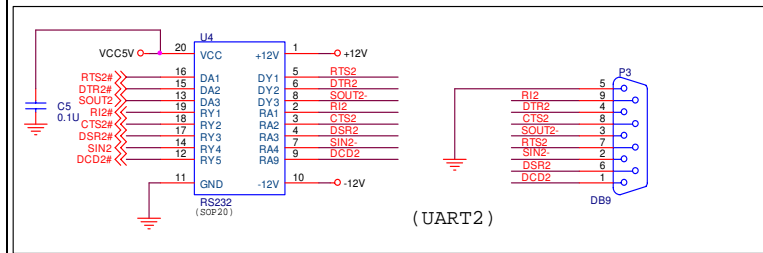
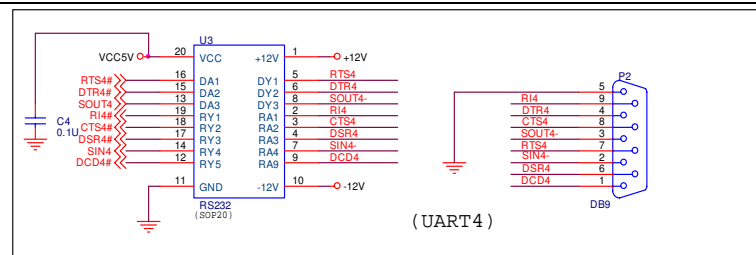
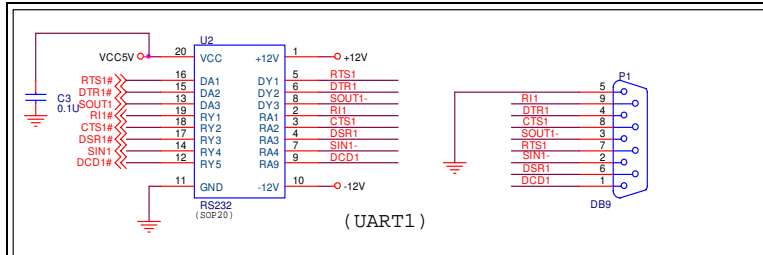

Title		
Feature Integration Technology Inc.		
Size	Document Number	Rev
B	UART and IrDA	0.2
Date:	Tuesday, September 16, 2003	Sheet 2 of 2