

F72814 Datasheet

Synchronous Buck PWM DC-DC Controller

Do Not Copy!

Release Date: July, 2007

Version: V0.23P

F72814 Datasheet Revision History

Version	Date	Page	Revision History
0.20P			Preliminary version
0.21P	Apr, 2006		
0.22P	May,2006		Re-compose
0.23P	Jul, 2007	3	Remove free run frequency
		4	Add dead time measurement loading
		8	Add typical characteristic diagram
		11	Update company address

Fintek Confidential
 Do Not Copy!

Please note that all data and specifications are subject to change without notice. All the trade marks of products and companies mentioned in this data sheet belong to their respective owners.

LIFE SUPPORT APPLICATIONS

These products are not designed for use in life support appliances, devices, or systems where malfunction of these products can reasonably be expected to result in personal injury. Customers using or selling these products for use in such applications do so at their own risk and agree to fully indemnify Fintek for any damages resulting from such improper use or sales.

Table of Content

1.	General Description	1
2.	Feature List	1
3.	Pin Configuration.....	2
4.	Pin Description.....	2
5.	Electrical Characteristic	2
6.	Block Diagram	4
7.	Function Description.....	5
7.1	Bootstrap Operation	5
7.2	Power On Reset.....	5
7.3	Soft-Start	6
7.4	Over-current Protection	6
7.5	Under-voltage Protection	6
7.6	Shutdown	7
7.7	VIN Sense	7
8.	Typical Characteristic	8
9.	Ordering Information	9
10.	Package Dimensions (8-SOP/150 mil)	11
11.	Application Circuit.....	12

1. General Description

The F72814 is a high-efficiency synchronous buck PWM controller that generates logic-supply voltages in PC based systems. This high-performance, single output device includes internal soft-start, frequency-compensation networks, power good signal with delay, and integrates all of the control, output adjustment, monitoring and protection functions into a single package. This device operates at a fixed frequency, 300K Hz and provides an optimum compromise between efficiency, external component size, and cost. Adjustable over-current protection (OCP) monitors the voltage drop across the RDS (ON) of the lower MOSFET for synchronous buck PWM DC-DC controller. The over-current function cycles the soft-start in 4-times hiccup mode to provide fault protection, and in a routine hiccup mode for under-voltage protection.

2. Feature List

- ◆ Provides one synchronous rectified buck DC-DC PWM controller
 - Fast transient response (high bandwidth error amplifier; full 0~80% duty cycle)
 - Fixed operation frequency : 300KHz
 - Single loop voltage-mode control
 - Few external components
 - Output range adjustable down to 0.8V
- ◆ Operates under 5V to 12V input
- ◆ Drives all low cost N-channel MOSFETs
- ◆ Uses MOSFET $R_{DS(ON)}$ as over current monitor, and no current sense resistor is required
- ◆ 0.8V internal reference voltage
 - $\pm 2\%$ accuracy over line, load and temperature
- ◆ Internal soft-start (typically 3 ms)
- ◆ Internal loop compensation
- ◆ Under voltage fault monitoring and protection
- ◆ Over voltage protection
- ◆ Adaptive Non-Overlapping Gate Driver
- ◆ 8-SOP package (150 mil)

3. Pin Configuration

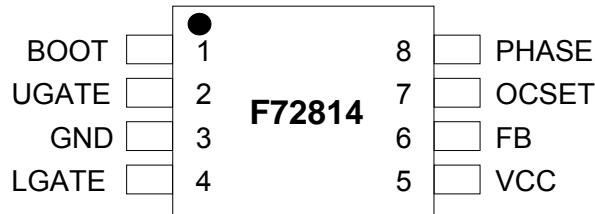

4. Pin Description

Pin No	Pin Name	Description
1	BOOT	Bootstrap supply pin for the upper gate driver. Connect the bootstrap capacitor between BOOT pin and the PHASE pin. The bootstrap capacitor provides the charge to turn on the upper MOSFET.
2	UGATE	Higher gate drive output. Connect this pin to gate of the high side MOSFET
3	GND	Power ground pin for the chip
4	LGATE	Lower gate drive output. Connect this pin to gate of the low side MOSFET
5	VCC	IC supply voltage. This voltage is monitored for power-on-reset purpose.
6	FB	Inverting input of the error amplifier used to compensate the feedback loop of the PWM controller.
7	OCSET/SD	This is multi-function pin. Connecting a resistor ROCSET from this pin to PHASE, and an internal 40uA current source from VCC. OCSET voltage can sense loading status when low side MOSFET turn on. When OCSET voltage is under 0.1V, shut down (SD) function will be enabled.
8	PHASE	Connect this pin to the source of the upper MOSFET and the drain of the lower MOSFET.

5. Electrical Characteristic

Absolute Maximum Ratings

PARAMETER	SYMBOL	RATINGS	UNIT
IC supply voltage	VCC	15	V
PHASE to GND	VPHASE – GND	15	V
BOOT to PHASE	VBOOT - VPHASE	15	V

F72814

BOOT to GND	VBOOT - GND	VCC + 15	V
PWM controller outputs	UGATE	(VPHASE - 0.3) to (VBOOT + 0.3)	V
PWM controller outputs	LGATE	(GND - 0.3) to (VCC + 0.3)	V
Feedback voltages	FB	(GND - 0.3) ~ 7	V
ESD classification	HBM	2	kV
※ Maximum junction temperature (plastic package)	T _j	150	°C
※ Maximum storage temperature	T _{STO}	-65 ~ 150	°C
※ Maximum lead temperature (soldering 10s)		260	°C

Note: If ICs are stressed beyond the limits listed in the “absolute maximum ratings”, they may be permanently destroyed. These are stress ratings only and functional operations of the device at these or any other condition beyond those indicated under “recommended operating conditions” are not implied. Exposure to absolute maximum rated conditions for extended periods may affect device reliability.

Recommended Operating Conditions

PARAMETER	SYMBOL	RATINGS	UNIT
Supply Voltage	VCC	5 ± 5%, 12 ± 10%	V
Ambient Temperature		0 ~ 70	°C
Junction Temperature		0 ~ 125	°C

Package thermal information

PARAMETER	SYMBOL	SOIC	UNIT
Thermal resistance junction-ambient	R _{th_ja}	160	°C/W

DC and AC electrical characteristics (VCC = 12V, TA = 25°C)

PARAMETER	SYMBOL	TEST CONDITIONS	MIN.	TYP.	MAX.	UNIT
VCC SUPPLY CURRENT/Regulated Voltage						
Nominal supply current 5VCC	I _{CC}	UGATE, LGATE and DRIVE2 open		6	15	mA
POWER-ON RESET						
Rising VCC threshold				4.1	4.4	V
Falling VCC threshold				3.6	3.75	V
OSCILLATOR AND Protection						
Free running frequency	F _{OSC}		250	300	350	kHz
※ Ramp Amplitude	ΔV _{OSC}			1.5		V _{P-P}
FB Under Voltage Trip		FB Falling	0.48	0.5	0.52	V
OCSET Current Source	I _{OCSET}		35	40	45	uA
Soft-start interval	T _{SS}		1	3	6	ms

F72814

PARAMETER	SYMBOL	TEST CONDITIONS	MIN.	TYP.	MAX.	UNIT
Dead time	T_{DT}	2V to 2V, Loading =2A	10		100	ns
REFERENCE VOLTAGE						
Reference voltage	V_{REF}	VCC=5V, T= 25	0.784	0.8	0.816	V
PWM CONTROLLER GATE DRIVERS						
Upper Drive Source	R_{UGATE}	VDS = 1V, VGS = 12V,		5	10	Ω
Upper Drive Sink	R_{UGATE}	VDS = 1V, VGS = 12V		4	8	Ω
Lower Drive Source	R_{LGATE}	VDS = 1V, VGS = 12V		4	8	Ω
Lower Drive Sink	R_{LGATE}	VDS = 1V, VGS = 12V		3	5	Ω
Error Amplifier						
※ E/A Transconductance	gm			1.67		$\mu A/V$
※ DC Gain	A0			85°		dB

※: Design Guarantee

6. Block Diagram

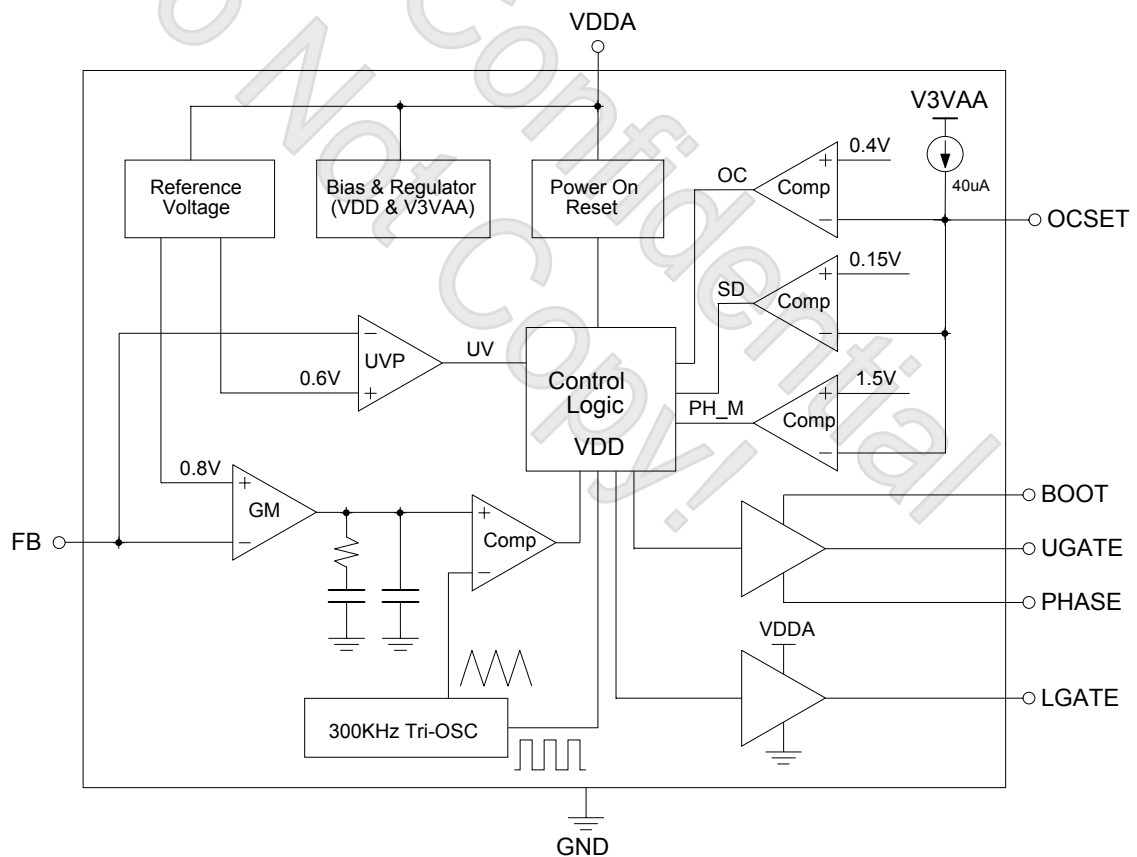

Figure 1: Block Diagram

7. Function Description

The F72814 is a single PWM DC-DC converter controller for application which requires high current such as motherboard, graphic card etc. The F72814 uses voltage mode PWM controller with fast transient response (driving two external N-channel MOSFETs in a synchronous rectified buck converter topology) and integrates some functions such as soft-start, over current and short circuit protections etc. Over current protection is achieved by monitoring the PHASE negative voltage when heavy loading without the need of a current sensing resistor and short circuit condition is detected through FB pin. If over current condition occurs, the F72814 will initiate the soft start cycle. After two cycles and the fault condition persist, the controller will go into shut down status. In shut down status, both gate drive signals will be low. To restart the controller, either recycling VCC supply or momentarily pulling the OCSET pin below 0.15V. If under voltage condition occurs, it will keep hiccup mode in this event.

7.1 Bootstrap Operation

In the single power supply system, UGATE is powered by an external bootstrap circuit as Figure 3. The Boot capacitor, C_{BOOT} is charged and generated a floating reference voltage at PHASE pin. Typically, a 0.1 μ F C_{BOOT} is enough for the most of applications. The C_{BOOT} capacitor is refreshed and charged to a voltage of “VCC – Diode Drop” while low side power MOS turns on.

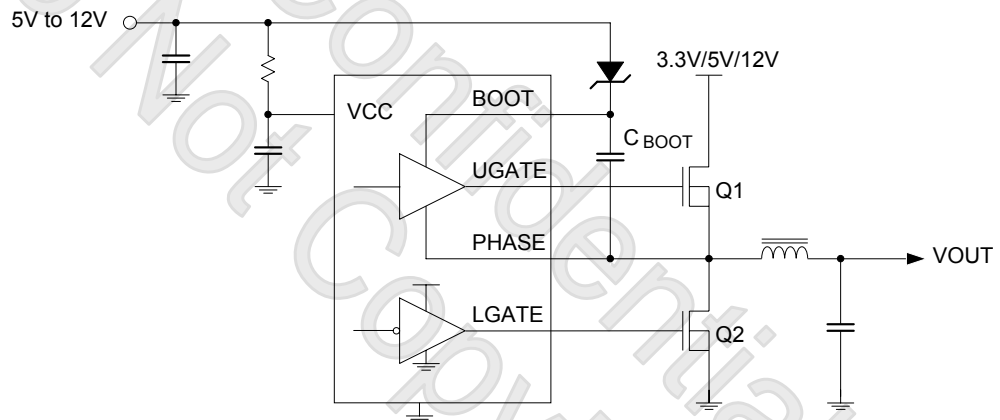

Fig 2. Power Supply Operation.

7.2 Power On Reset

The F72814S Power-on-reset monitors VCC supply voltage and input voltage at OCSET pin. POR level is 4.1V with 0.5V hysteresis at VCC voltage and 0.15V at OCSET voltage, The POR function initiates soft-start operation and resets control logic after the supply voltages exceeds its POR threshold voltage.

7.3 Soft-Start

When the POR function initiates the digital soft-start sequence, PWM error amplifier reference inputs are forced to track a voltage level proportional to the soft-start voltage. As the soft-start voltage slews up, the PWM comparator regulates the output relative to the tracked soft-start voltage, and slowly charges the output capacitor(s). In the digital soft-start sequence initiated by the POR function, the soft start function is used to prevent surge current from power supply input during power on. The soft start duration is 3mS in typical case.

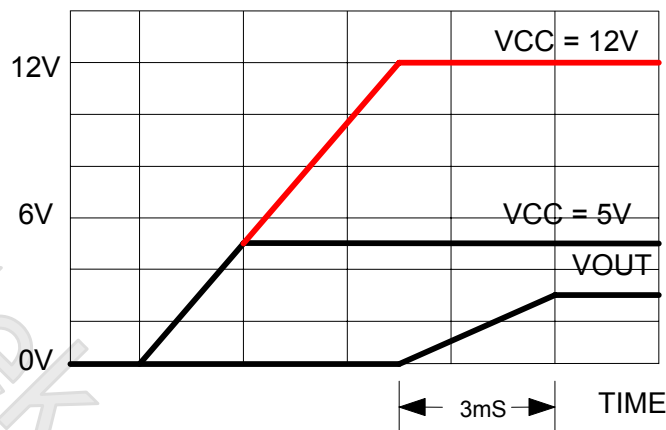

Figure 3 : Soft start duration

7.4 Over-current Protection

To sense the low-side MOSFET's RDS (ON) to set over-current trip point. Connecting a resistor (ROCSET) from this pin to PHASE to set the over-current trip point, ROCSET, an internal 40μA current source, and the lower MOSFET on resistance, RDS (ON), sets the converter over-current trip point (IOCSET) according to the following equation:

$$I_{OCSET} = \frac{40\mu A \times R_{OCSET} - 0.4V}{R_{DS(ON)} \text{ of the lower MOSFET}}$$

7.5 Under-voltage Protection

If the FB voltage drops under 0.5V, a fault signal is generated. When under voltage condition occurs, it will keep hiccup mode in this event.

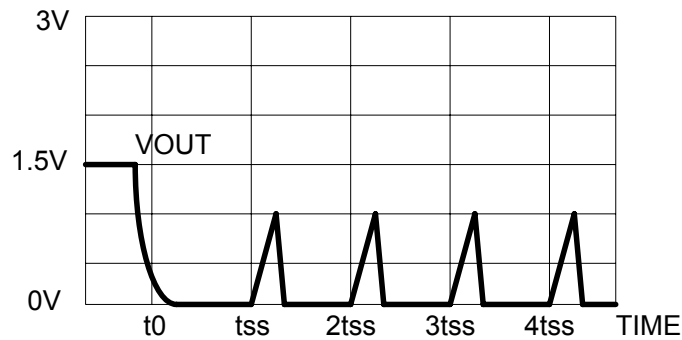

Figure 4 : Under voltage event occur

But UV_FB has some differences from OC, it always trigger VIN power sensing after 4 times hiccup.

7.6 Shutdown

It can shut down the F72814 PWM controller to pull low the OCSET pin under 0.15V.

7.7 VIN Sense

The F72814 Vin power is sensed by OCSET voltage at first soft start event, when soft start event occurs. UGATE pulse will be enabled, and the F72814 detects the first ten UGATE high pulse. If there are four PH_M pulse during the ten pulse period, it means Vin ready, If Vin is ready, VOUT will be ramped up in next soft start event. Otherwise, we will check Vin voltage at the next soft start event.

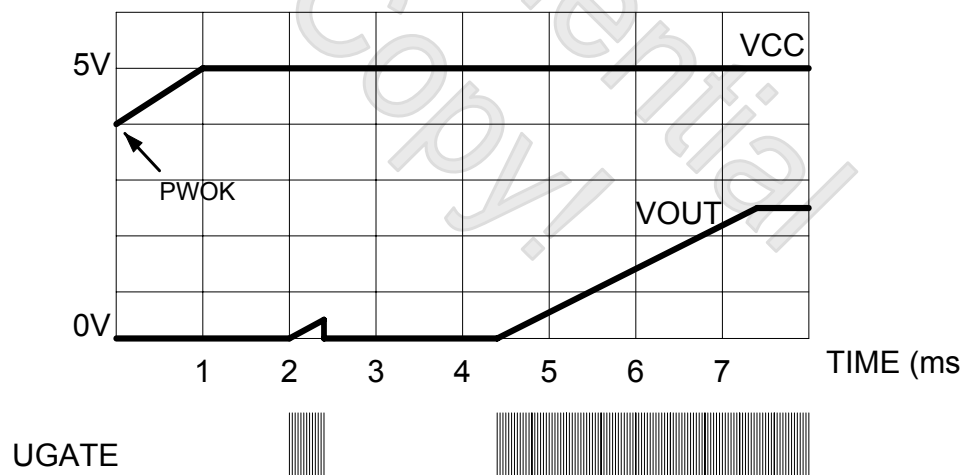
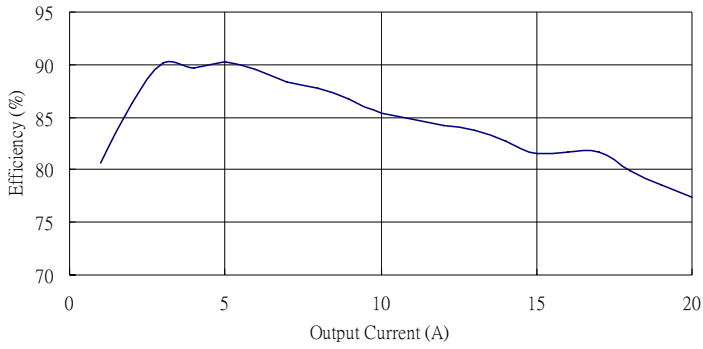

Figure 5 :

F72814

8. Typical Characteristic

Efficiency V.S. Output Current

 $V_{CC}=12V, V_{IN}=5V, V_{OUT}=2.5V$

Efficiency V.S. Output Current

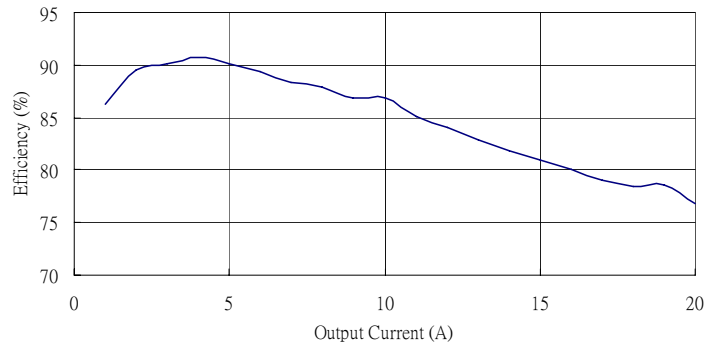
 $V_{CC}=5V, V_{IN}=5V, V_{OUT}=2.5V$

Reference Voltage V.S. Temperature

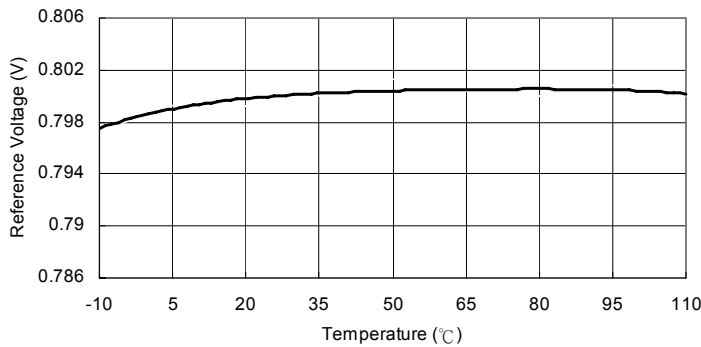

Frequency V.S. Temperature

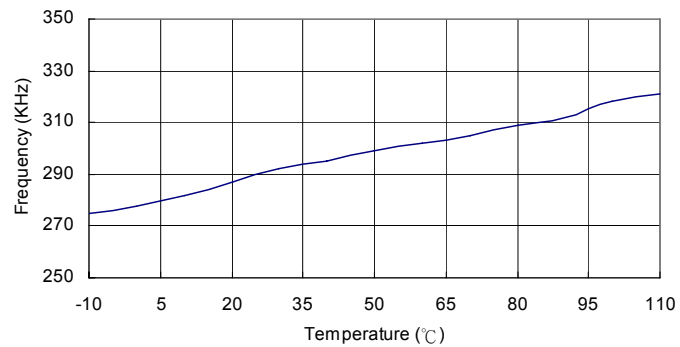

POR V.S. Temperature

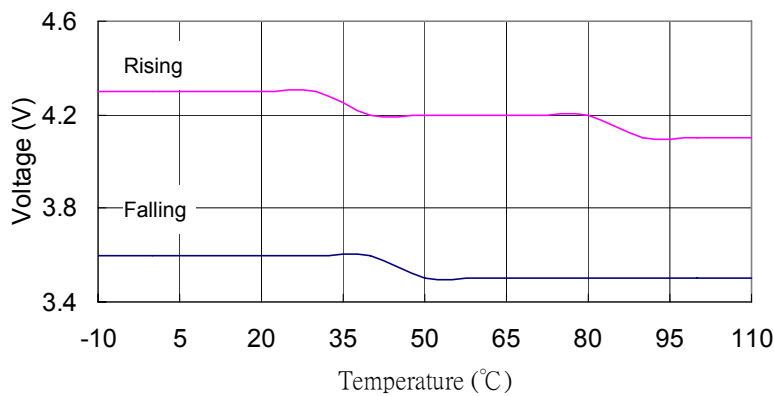

F72814

Dead Time (Rising)

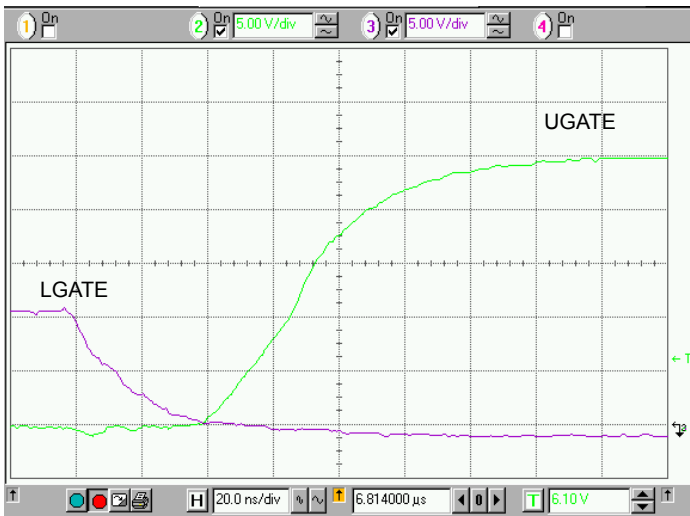

Time 20.0ns/Div.

Dead Time (Falling)

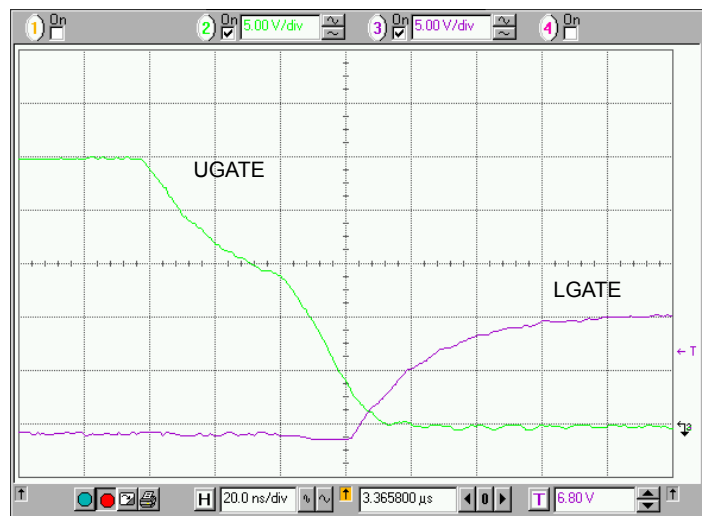

Time 20.0ns/Div.

 $V_{CC}=12V, V_{IN}=5V, I_{OUT}=2.5A$

Under Voltage Protection

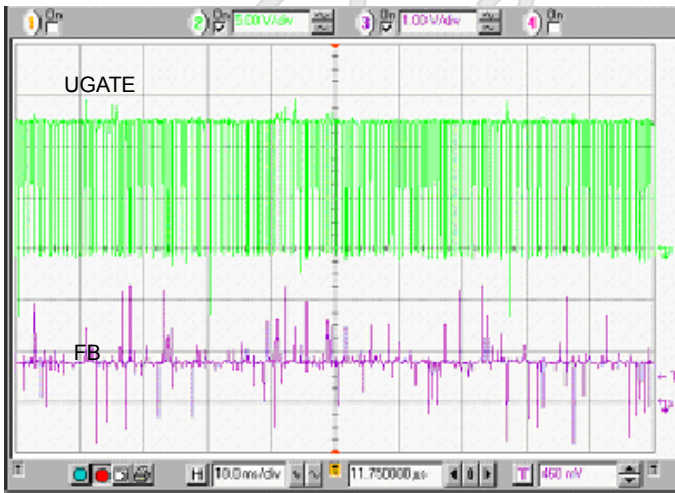

FB > 0.5V



FB < 0.5V

Transient Response Time
Rising

UGATE, 20.0V/Div.

 V_{OUT} , 100mV/Div.

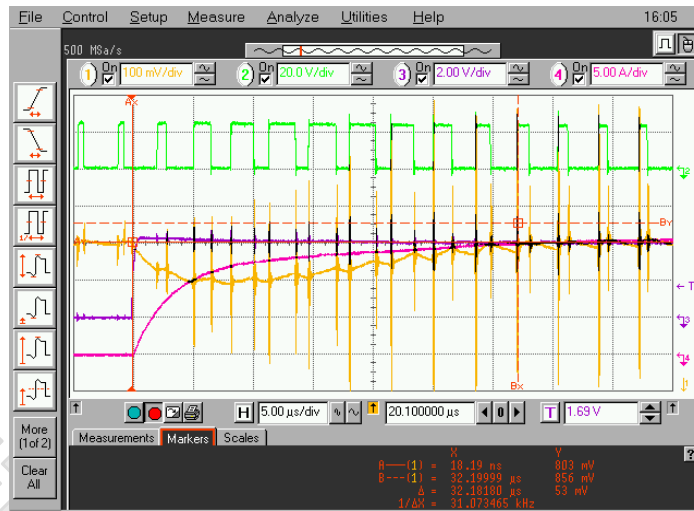
 I_{OUT} , 5.0A/Div

 $V_{CC}=5V$ $V_{IN}=5V$ $I_{OUT}=0-15A$
Falling

UGATE, 20.0V/Div.

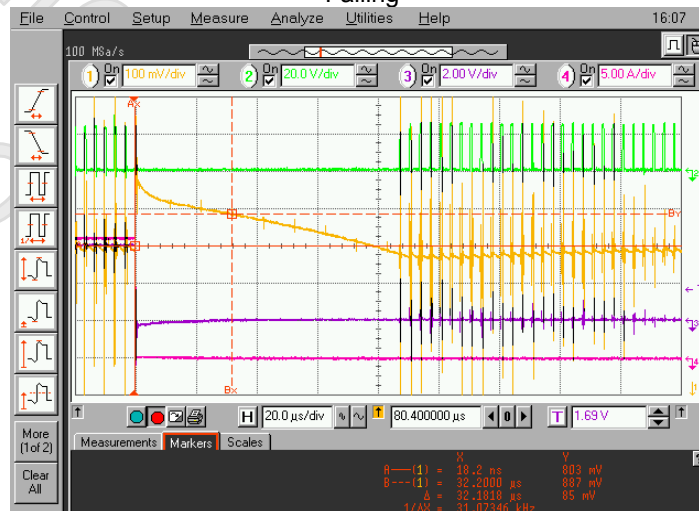
 V_{OUT} , 100mV/Div.

 I_{OUT} , 5.0A/Div

 $V_{CC}=5V$ $V_{IN}=5V$ $I_{OUT}=15-0A$

9. Ordering Information

Part Number	Package Type	Production Flow
F72814SG	8-SOP (Green Package)	Commercial, 0°C to +70°C

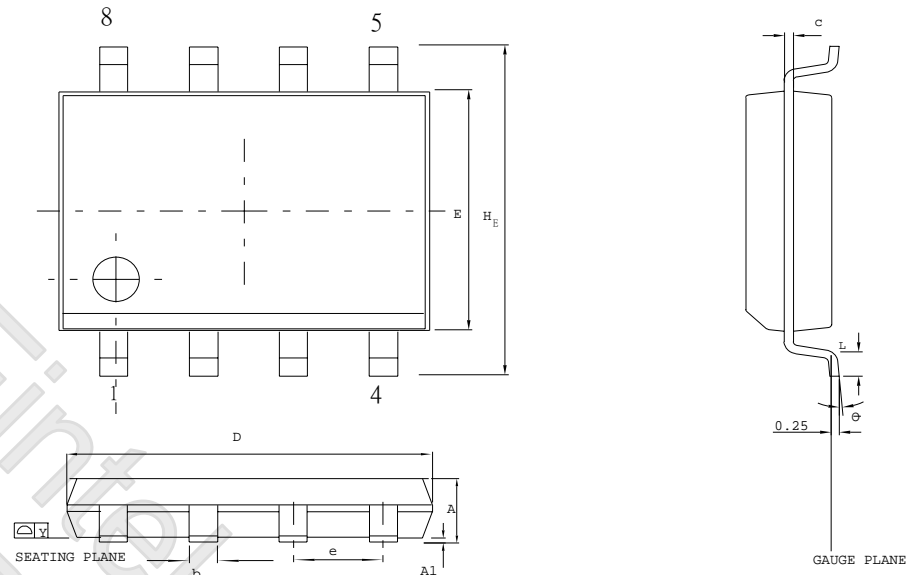
10. Package Dimensions (8-SOP/150 mil)



Control dimensions are in millimeters .

SYMBOL	DIMENSION IN MM		DIMENSION IN INCH	
	MIN.	MAX.	MIN.	MAX.
A	1.35	1.75	0.053	0.069
A1	0.10	0.25	0.004	0.010
b	0.33	0.51	0.013	0.020
c	0.19	0.25	0.008	0.010
E	3.80	4.00	0.150	0.157
D	4.80	5.00	0.188	0.196
e	1.27 BSC		0.050 BSC	
H _E	5.80	6.20	0.228	0.244
Y	0.10		0.004	
L	0.40	1.27	0.016	0.050
θ	0	10	0	10

Feature Integration Technology Inc.

Headquarters

3F-7, No 36, Tai Yuan St.,
Chupei City, Hsinchu, Taiwan 302, R.O.C.

TEL : 886-3-5600168

FAX : 886-3-5600166

www: <http://www.fintek.com.tw>

Taipei Office

Bldg. K4, 7F, No.700, Chung Cheng Rd.,
Chungho City, Taipei, Taiwan 235, R.O.C.

TEL : 866-2-8227-8027

FAX : 866-2-8227-8037

Please note that all datasheet and specifications are subject to change without notice. All the trade marks of products and companies mentioned in this datasheet belong to their respective owner

F72814S

11. Application Circuit

