

# **F71612A**

---

**USB CIR Chip with RC6 and QP Protocol  
(Receiver and Transmitter)**

**Release Date: June, 2009  
Version: V0.20P**

**F71612A Datasheet Revision History**

Version	Date	Page	Revision History
V0.20P	2009/6/1	-	Release Version

Fintek Confidential  
Do Not Copy!

Please note that all data and specifications are subject to change without notice. All the trade marks of products and companies mentioned in this data sheet belong to their respective owners.

**LIFE SUPPORT APPLICATIONS**

These products are not designed for use in life support appliances, devices, or systems where malfunction of these products can reasonably be expected to result in personal injury. Customers using or selling these products for use in such applications do so at their own risk and agree to fully indemnify Fintek for any damages resulting from such improper use or sales.

## Table of Content

---

---

1.	General Description .....	1
2.	Feature List .....	1
3.	Key Specification.....	1
4.	Pin Configuration.....	2
5.	Pin Description.....	2
6.	Function Description.....	4
7.	Electron Characteristic.....	9
8.	Ordering Information.....	12
9.	Package Dimensions .....	13
10.	Application Circuit.....	14

Fintek Confidential  
Do Not Copy!

## 1. General Description

The F71612A is a USB IR chip and compatible for Microsoft Windows Vista and Windows 7 IR Receiver or Transceiver Emulation Device. It Supports 2 IR transceiver functions for blaster application and two IR receivers with long range frequency and wideband application.

In USB interface function, The F71612A communications with host by full-speed USB interface (12Mb/s). It supports 3 suits endpoint, one control endpoint( endpoint zero) is for bus enumeration, one output endpoint is for Microsoft Windows Vista/7 IR Receiver or Transceiver Emulation Device command and one input endpoint is transmit IR information to host.

In I2C interface function, The F71612A builds 256 bytes SRAM to save flash/ROM information from I2C for USB bus enumerations. The I2C flash/ROM contains IdVendor/ IdProduct/ BcdDevice/ Manufacturer string / IProduct string / iSerialNumber string information.

In power function, the F71612A supports remote-wakeup function during USB interface, when PC system into S3 state. The F71612A decodes IR protocol is the same power key of remote control. The F71612A is asserted USB interface to wakeup PC system. Others also provide hardware pin PSOUT# for system wakeup, when PC system in to S5 state, the F71612A is asserted PSOUT# pin to wakeup PC system.

## 2. Feature List

- Support Microsoft Windows Vista / Windows 7 IR Receiver
- Support RC6 and Quatro Pulse protocols
- Support Learning Function
- Support Remote Wake-up Capability
- Hardware Base Implementation
- Provide Data Receiver LED
- Support 2 IR Transceiver Function for Blaster Application
- One IR Receiver with Long Range Frequency and Another with Wideband Application
- I2C Interface for Related ID Data Reading.
- USB Interface for System Connection.
- Power by 3Vcc and Packaged in 16-SSOP Green Package.

## 3. Key Specification

- Supply Voltage 3.0V to 3.6V



# F71612A

- IN<sub>ts\_5v</sub> - TTL level input pin with schmitt trigger and 5V input tolerance.  
 IN<sub>t</sub> - TTL level input pin.  
 P - Power.

Pin No	Pin Name	Type	PWR	Description
1	D+	I/O <sub>12t_1.5k</sub>	VDD	D+. Different data bus conforming to USB standard. Internal pull high 1.5kΩ.
2	D-	I/O <sub>12t</sub>	VDD	D-. Different data bus conforming to USB standard.
3	PSOUT#	OD <sub>12_5v</sub>	VDD	Panel Switch Output. This pin is low active and pulse output. It is power on request output.
4	STATE_SEL	IN <sub>ts</sub>	VDD	This pin is for wake up function. <b>For Portable Product</b> → Pull this pin to high for USB wake up. <b>For MB System Product</b> → Pull this pin to high and suggest connecting with one of S4/S5/GPIO pin. MB System in S4/S5 state: Wake up signal will be asserted by PSOUT# pin in S4/S5 state. MB System in S3 state: Wake up signal will be asserted by USB interface in S3 state.
5	XTALIN	IN <sub>t</sub>	VDD	12MHz clock input.
6	XTALOUT	O <sub>12</sub>	VDD	12MHz clock output.
7	PWCTL	OD <sub>12</sub>	VDD	RX_LR learning power control pin. Suggest external pull high to 3.3V.
8	GND	P	VDD	Ground pin.
9	SCL	OD <sub>12_5v</sub>	VDD	I2C interface serial clock
10	SDA	OD <sub>12_5v</sub>	VDD	I2C interface serial data
11	TX1	O <sub>12</sub>	VDD	IR transmits port 1. Pull down 100k resistor to ground (TX/RX functions selection). No resistor connects to ground (RX function only).
12	TX0	O <sub>12</sub>	VDD	IR transmits port 0. Pull down 100k resistor to ground (TX/RX functions selection). No resistor connects to ground (RX function only). (P.S One of TX pins pull down 100K resistor to ground, chip feature will be selected to TX and RX functions, if not, chip will be selected to RX function only.)
13	LED#	OD <sub>16_5v</sub>	VDD	LED output pin.
14	RX_LR#	IN <sub>ts_5v</sub>	VDD	IR receiver port1 ( wide band for learning)

# F71612A

15	RX_NR#	IN <sub>ts_5v</sub>	VDD	IR receiver port0 (long range)
16	VDD	P	VDD	Power supply input 3.3V

## 6. Function Description

### 6.1 USB function

The F71612A communications with host by full-speed USB interface (12Mb/s). It supports 3 suits endpoint, one control endpoint( endpoint zero) is for bus enumeration, one output endpoint is for Microsoft Windows Vista IR Receiver or Transceiver Emulation Device command and one input endpoint is transmit IR information to host.

Endpoint zero is special significance in USB system. It is a control endpoint, and is required by every device. Only control endpoint accept special setup token that the host transfer command to device.

During enumeration, host requests GET\_DESCRIPTOR to device and device return information (over in endpoint zero) as what device driver top load. The below table is about F71612A descriptor.

offset	Field	size	Value
0	BLength	1	0x12
1	bDescriptor Type	1	0x01
2	BcdUSB	2	0x0200
4	bDeviceClass	1	0x00
5	bDeviceSubClass	1	0x00
6	bDeviceProtocol	1	0x00
7	bMaxPacketSize	1	0x10
8	IdVendor	2	0x1934
10	IdProduct	2	0x5168
12	BcdDevice	2	0x0000
14	Manufacturer	1	0x01
15	IProduct	1	0x02
16	iSerialNumber	1	0x03
17	bNumConfiguration	1	0x01

Table 6-1 Device Descriptor

offset	Field	size	Value
0	BLength	1	0x09
1	bDescriptor Type	1	0x02
2	wTotalLength	2	0x0020
4	bNumInterface	1	0x01
5	bConfigurationValue	1	0x01
6	iConfiguration	1	0x00
7	BmAttributes	1	0xa0

## F71612A

8	MaxPower	1	0x32
---	----------	---	------

Table 6-2 Configuration Descriptor

offset	Field	size	Value
0	BLength	1	0x09
1	bDescriptor Type	1	0x04
2	wInterfaceNumber	1	0x00
3	bAlternateSetting	1	0x00
4	bNumEndpoints	1	0x02
5	bInterfaceClass	1	0xff
6	bInterfaceSubClass	1	0xff
7	bInterfaceProtocol	1	0xff
8	lInterface	1	0x00

Table 6-3 Interface Descriptor

offset	Field	size	Value
0	BLength	1	0x07
1	bDescriptor Type	1	0x05
2	bEndpointAddress	1	0x81
3	BmAttributes	1	0x02
4	wMaxPacketSize	2	0x0010
6	BInterval	1	0x00

Table 6-4 In Endpoint Descriptor

offset	Field	size	Value
0	BLength	1	0x07
1	bDescriptor Type	1	0x05
2	bEndpointAddress	1	0x01
3	BmAttributes	1	0x02
4	wMaxPacketSize	2	0x0010
6	BInterval	1	0x00

Table 6-5 Out Endpoint Descriptor

The string table 1 is about manufacturer information, its' contents is "FINTEK", the string table 2 is about Product information, its contents is "eHome Infrared Transceiver. The string table 3 is about serial number information, its contents is "88636562727801".

In power function, The F71612A supports remote-wakeup function for USB interface, when PC system into S3 state. The F71612A decodes IR protocol is the same power key of remote control. The F71612A is asserted USB interface to wakeup PC system.

The F71612A is compatible for Microsoft Windows Vista / 7 IR Receiver or Transceiver Emulation Device. The F71612A support Microsoft Compatible Device Descriptor and Extended Compact ID Descriptor are used to tell the host what type of device the emulation is. Emulation Device driver transmits command over out endpoint1 and device return information over in endpoint1.

## F71612A

About descriptor and command information, reference Microsoft Windows Vista / 7 IR Receiver or Transceiver Emulation Device spec.

### 6.2 IR function

The F71612A Supports 2 IR transceiver functions for blaster application and two IR receivers with long range frequency and wideband application. The wide-band receiver is necessary to support IR learning, which is necessary to support IR-blasting and set-top box control.

The long-range receiver is a receiver which has the following characteristics:

1. Works at a distance of 10 meters.
2. Demodulates the signal inside the receiver part
3. Has a BPF which works with carriers from 32-60 kHz.

The wide-band receiver is a receiver part which has the following characters:

1. Works at a distance of approximately 5 centimeters.
2. Does not demodulate the signal inside the receiver part
3. Works with carriers from 32-60 kHz. (Probably doesn't have a BPF, but still has the same (or wider) range.

About IR information, reference Microsoft Windows Vista / 7 IR Receiver or Transceiver Emulation Device spec.

### 6.3 Wakeup function

The F71612A Supports 2 kinds of wakeup system function, PSOUT and remote wakeup for USB interface. The F71612A detect idle state on USB bus for more than 3.0ms, it is into suspend state.

In Suspend state, the F71612A decodes IR protocol information is the same power key of remote controller. It asserted PSOUT and USB interface. Reference the below figure

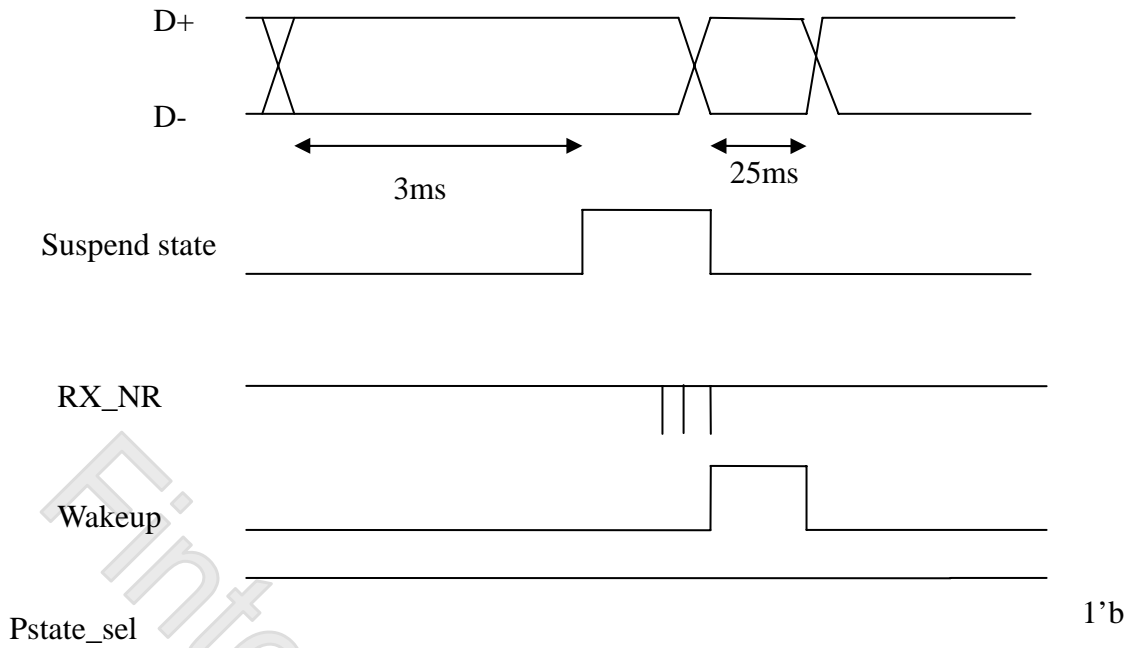

Figure 6-3-1 USB remote wakeup

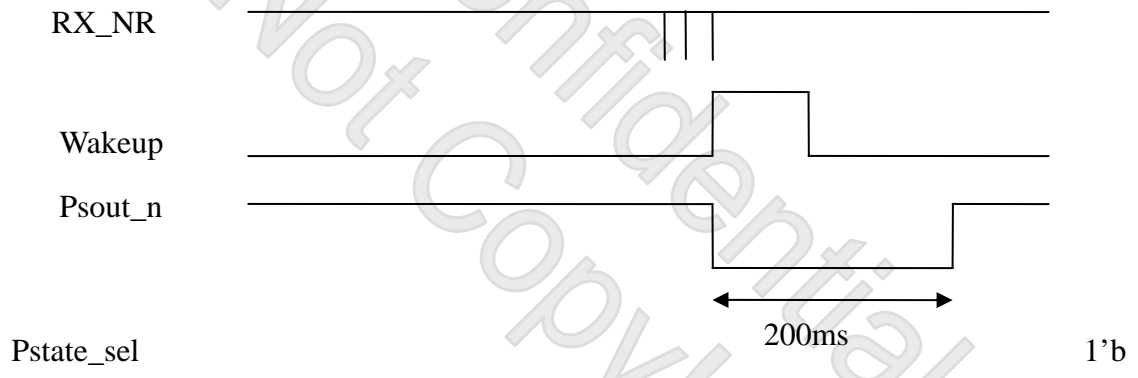

Figure 6-3-2 PSOUT wakeup

## 6.4 I2C interface function

The F71612A Supports 1 suit I2C interface to get USB description information and builds 256 bytes RAM to save vendor USB description information. When power is ready, I2C function start to load USB description into 256 bytes RAM, and expect host requests GET\_DESCRIPTOR to

## F71612A

F71612A which returns vendor USB description, if i2c flash/ROM connect with F71612A. The contents of I2C flash /ROM format is below table.

When F71612A does not finish loading 256 bytes information from I2C flash/ROM, F71612A disable PAD 1 internal pull high 1.5k, still finish loading, F71612A enable PAD 1 internal pull high 1.5k.

0x0	Security code	0x55
0x1	Security code	0xaa
0x2	IdVendor length	0x02
0x3	IdVendor low byte	IdVendor low byte
0x4	IdVendor high byte	IdVendor high byte
0x5	IdProduct length	0x02
0x6	IdProduct low byte	IdProduct low byte
0x7	IdProduct high byte	IdProduct high byte
0x8	BcdDevice length	0x02
0x9	BcdDevice low byte	BcdDevice low byte
0xa	BcdDevice high byte	BcdDevice high byte
0xb	Manufacturer string length	Define by vendor content
0xb+ Manufacturer string length	Manufacturer string content	Define by vendor content
0xb+ Manufacturer string length + 1	IProduct string length	Define by vendor content
0xb+ Manufacturer string length + IProduct string length + 1	IProduct string content	Define by vendor content
0xb+ Manufacturer string length + IProduct string length + 2	ISerialNumber string length	Define by vendor content
0xb+ Manufacturer string length + IProduct string length + 2	IProduct string length	Define by vendor content

Table 6-4-1 I2C flash/ROM USB description format

## 7. Electron Characteristic

### Absolute Maximum Ratings

PARAMETER	RATING	UNIT
Power Supply Voltage	-0.5 to 5	V
Input Voltage	-0.5 to VDD+0.5	V
Operating Temperature	0 to +70	° C
Storage Temperature	-55 to 150	° C

Electrical characteristics table

Note: Exposure to conditions beyond those listed under Absolute Maximum Ratings may adversely affect the life and reliability of the device.

### DC Characteristics

( $T_a = 0^\circ\text{C}$  to  $70^\circ\text{C}$ ,  $V_{DD} = 3.3\text{V} \pm 10\%$ ,  $V_{SS} = 0\text{V}$ ) (Note)

PARAMETER	RATING	UNIT
Operating Voltage	3.0 to 3.6	VDD

Operating Voltage table

PARAMETER	SYM.	MIN	TYP	MAX.	UNIT	CONDITIONS
<b>I/O<sub>12t</sub> - TTL level bi-directional pin with 12 mA source-sink capability(3.3V)</b>						
Input Low Voltage	V <sub>IL</sub>			0.8	V	
Input High Voltage	V <sub>IH</sub>	2.0			V	
Output Low Current	I <sub>OL</sub>		12		mA	0.4V
Output High Current	I <sub>OH</sub>		12		mA	2.4V
Input High Leakage	I <sub>LIH</sub>	-1		1	μA	
Input Low Leakage	I <sub>LIL</sub>	-1		1	μA	
<b>OD<sub>12_5v</sub> - Open-drain output pin with 12mA source-sink capability(3.3V), 5V tolerance</b>						
Output Low Current	I <sub>OL</sub>		12		mA	0.4V
<b>OD<sub>16_5v</sub> - Open-drain output pin with 16mA source-sink capability(3.3V), 5V tolerance</b>						
Output Low Current	I <sub>OL</sub>		16		mA	0.4V
<b>O<sub>12</sub> - Output pin with 12mA source-sink capability(3.3V)</b>						
Output Low Current	I <sub>OL</sub>		12		mA	0.4V
Output HIGH Current	I <sub>OH</sub>		12		mA	2.0V
<b>IN<sub>ts</sub> - TTL level input pin and schmitt trigger</b>						
Input Low Threshold Voltage	V <sub>t-</sub>			0.8	V	
Input High Threshold Voltage	V <sub>t+</sub>	2.0			V	
Hysteresis			0.5		V	
Input High Leakage	I <sub>LIH</sub>			+1	μA	
Input Low Leakage	I <sub>LIL</sub>	-1			μA	
<b>IN<sub>t</sub> - TTL level input pin</b>						
Input Low Threshold Voltage	V <sub>t-</sub>			0.8	V	
Input High Threshold Voltage	V <sub>t+</sub>	2.0			V	

# F71612A

Input High Leakage	ILIH			+1	$\mu\text{A}$	
Input Low Leakage	ILIL	-1			$\mu\text{A}$	
<b>IN<sub>ts .5v</sub> – TTL level input pin and schmitt trigger, 5 tolerance</b>						
Input Low Threshold Voltage	Vt-			0.8	V	
Input High Threshold Voltage	Vt+	2.0			V	
Hysteresis			0.5		V	
Input High Leakage	ILIH			+1	$\mu\text{A}$	
Input Low Leakage	ILIL	-1			$\mu\text{A}$	

PAD DC table

## USB Interface

Parameter	Symbol	Min.	Max.	Units
Rise Time	T <sub>FR</sub>	4	20	ns
Fall Time	T <sub>FF</sub>	4	20	ns
Differential Rise and Fall Time Matching	T <sub>FRFM</sub>	90	111.11	%
Driver Output Resistance	Z <sub>DRV</sub>	28	44	$\Omega$

USB AC

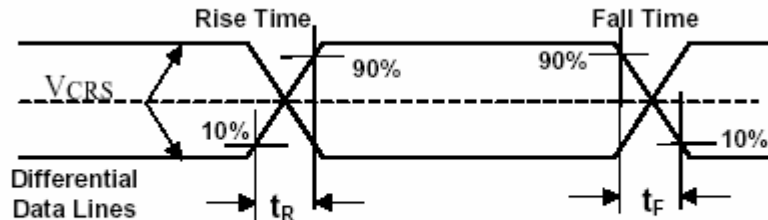

USB timing

Jitter Source	Full-speed			
	Next Transition		Paired Transition	
	Each (ns)	Total (ns)	Each (ns)	Total (ns)
<b>Source Driver Jitter</b>	2.0	2.0	1.0	1.0
Source Frequency Tolerance (worst-case)	0.21/bit	1.5	0.21/bit	3.0
<b>Source Jitter Total</b>		3.5		4.0
Hub Jitter	3.0	15.0	1.0	5.0
<b>Jitter Specification</b>		18.5		9.0
Destination Frequency Tolerance	0.21/bit	1.5	0.21/bit	3.0
<b>Receiver Jitter Budget</b>		20.0		12.0

USB Jitter

# F71612A

## I2C Interface

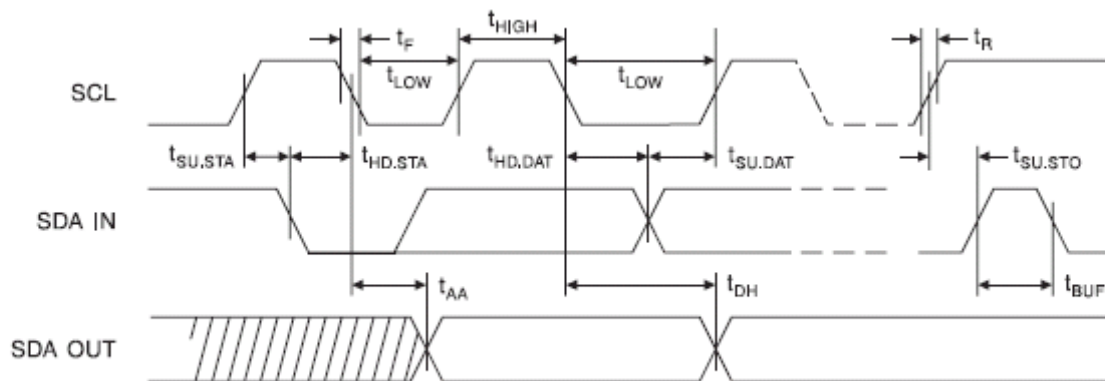

Symbol	Parameter	Min	Max	Units
$t_{SCL}$	Clock Frequency, SCL		400	kHz
$t_{LOW}$	Clock Pulse Width Low	1.2		us
$t_{HIGH}$	Clock Pulse Width High	0.6		us
$t_i$	Noise Suppression Time		50	ns
$t_{AA}$	Clock Low to Data Out Valid	0.1	0.9	us
$t_{BUF}$	Time the bus must be free before a new transmission can start	1.2		us
$t_{HD.STA}$	Start Hold Time	0.6		us
$t_{SU.STA}$	Start Set-up Time	0.6		us
$t_{HD.DAT}$	Data In Hold Time	0		us
$t_{SU.DAT}$	Data In Set-up Time	100		ns
$t_R$	Inputs Rise Time		300	ns
$t_F$	Inputs Fall Time		300	ns
$t_{SU.STO}$	Stop Set-up Time	0.6		us
$t_{DH}$	Data Out Hold Time	50		ns
$t_{WR}$	Write Cycle Time		5	ms
Endurance	5.0V, 25°C, Page Mode	1M		Write Cycles

## Spec. for Reliability

Test Item	Description	Y/N	Test Item	Description	Y/N
<b>ESD</b>	VHBM > 2KV, VMM > 200V VHBM > 8KV for USB PAD	Y	<b>TH(B)</b>	1000Hrs, 85% RH, 85°C	N
<b>Latch-UP</b>	$I_{tr} \Rightarrow 50 \sim 100mA$	Y	<b>PCT</b>	168 Hrs, 100% RH, 121°C	N
<b>HTSL</b>	1000 Hrs @ 150 °C	N	<b>TCT</b>	-65°C ~ 150°C, 200 Cycles	N
<b>HTOL</b>	168/500 Hrs Bias @ 125 °C	N	<b>TST</b>	-65°C ~ 150°C, 100 Cycles	N
<b>HAST</b>	96Hrs, 85% RH, 131°C	N			

## 8. Ordering Information

Part Number	Package Type	Production Flow
F71612AR	16-SSOP Green Package	Commercial, 0°C to +70°C

Fintek Confidential  
Do Not Copy!

## 9. Package Dimensions

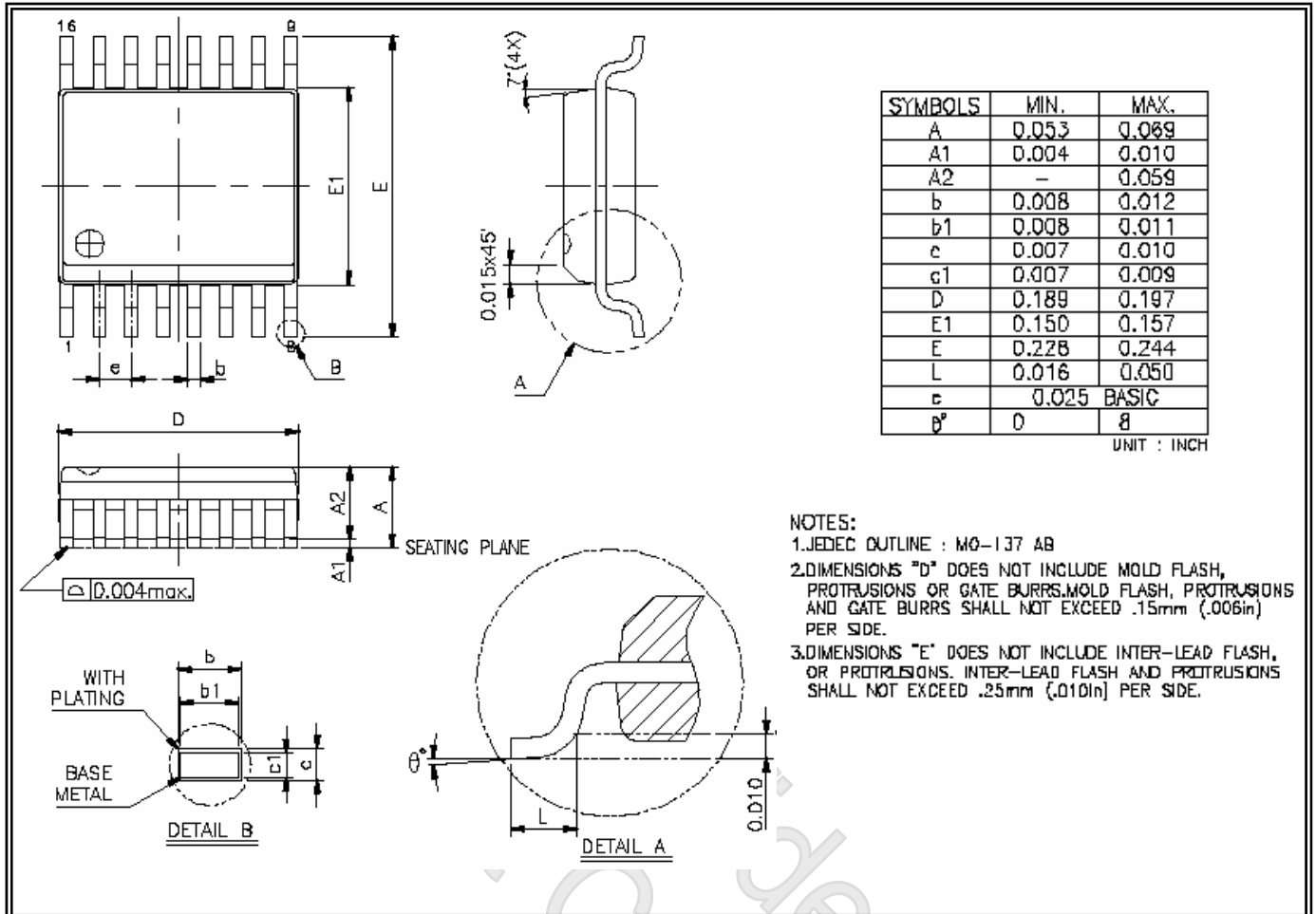
**16pin-SSOP ( 150 mil)**

**Headquarters**

3F-7, No 36, Tai Yuan St.,

Chupei City, Hsinchu, Taiwan 302, R.O.C.

TEL : 886-3-5600168

FAX : 886-3-5600166

 www: <http://www.fintek.com.tw>
**Taipei Office**

Bldg. K4, 7F, No.700, Chung Cheng Rd.,

Chungho City, Taipei, Taiwan 235, R.O.C.

TEL : 866-2-8227-8027

FAX : 866-2-8227-8037

Please note that all datasheet and specifications are subject to change without notice. All the trade marks of products and companies mentioned in this datasheet belong to their respective

# F71612A

## 10. Application Circuit

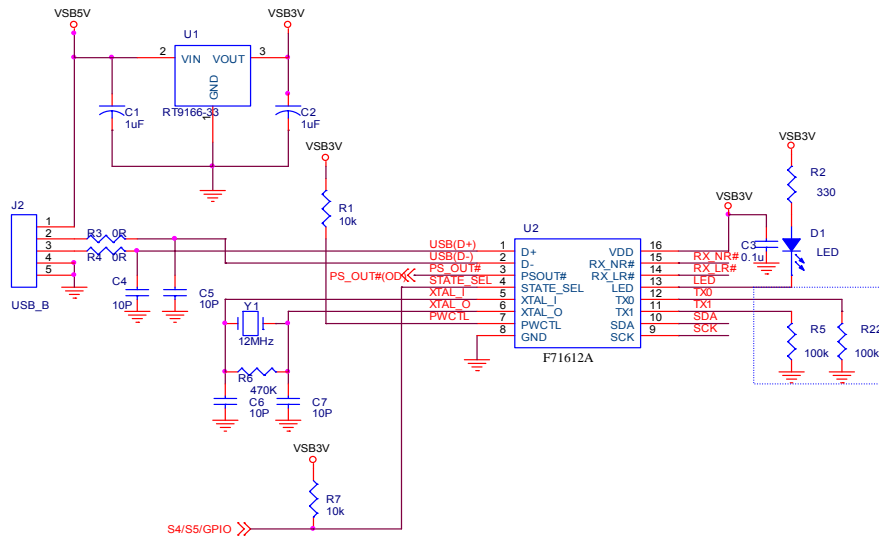

pull down resistor 100k to choose the F71612R function  
 Tx and rx : TX [0] or TX[1] connect pull down resistor 100k As power on.  
 Rx only : Tx [0] and tx[1] do not connect pull down resistor 100k As power on

Please pull pins SDA/SCK to high → IF EEPROM does not be used.

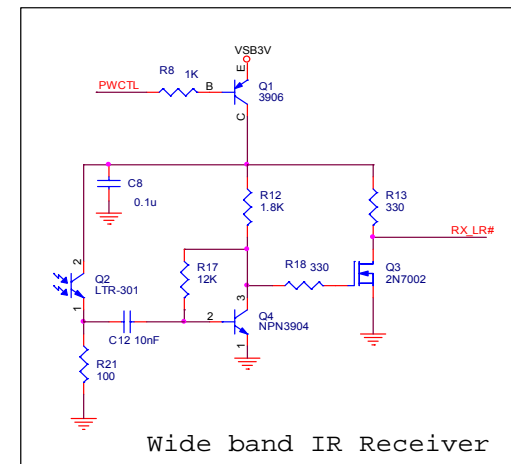
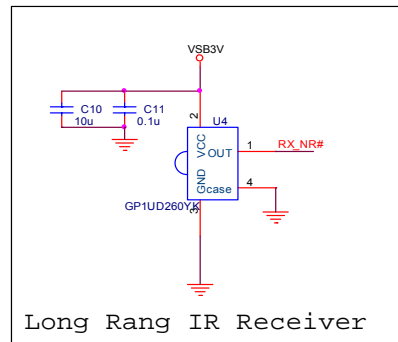
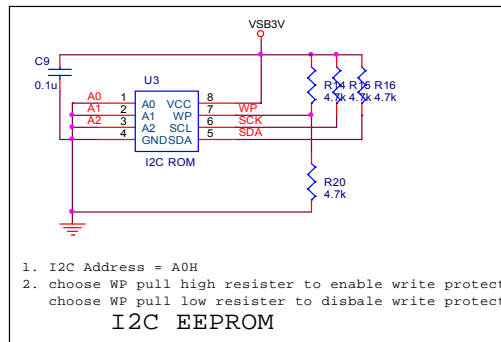
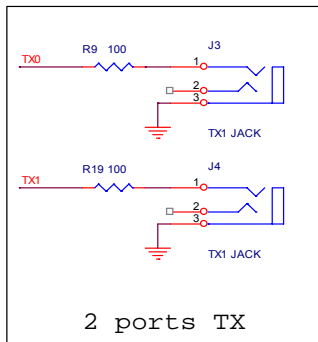

Title		
F71612A Application Circuit		
Size	Document Number	Rev
B	<Doc>	1.1
Date:	Friday, April 10, 2009	Sheet 1 of 1