ePSP6000

**RISC II Series
Microcontroller**

**Product
Specification**

Doc. VERSION 1.0

ELAN MICROELECTRONICS CORP.

November 2010



Trademark Acknowledgments:

IBM is a registered trademark and PS/2 is a trademark of IBM.

Windows is a trademark of Microsoft Corporation.

ELAN and ELAN logo  are trademarks of ELAN Microelectronics Corporation.

Copyright © 2007~2010 by **ELAN Microelectronics Corporation**

All Rights Reserved

Printed in Taiwan

The contents of this specification are subject to change without further notice. ELAN Microelectronics assumes no responsibility concerning the accuracy, adequacy, or completeness of this specification. ELAN Microelectronics makes no commitment to update, or to keep current the information and material contained in this specification. Such information and material may change to conform to each confirmed order.

In no event shall ELAN Microelectronics be made responsible for any claims attributed to errors, omissions, or other inaccuracies in the information or material contained in this specification. ELAN Microelectronics shall not be liable for direct, indirect, special incidental, or consequential damages arising from the use of such information or material.

The software (if any) described in this specification is furnished under a license or nondisclosure agreement, and may be used or copied only in accordance with the terms of such agreement.

ELAN Microelectronics products are not intended for use in life support appliances, devices, or systems. Use of ELAN Microelectronics product in such applications is not supported and is prohibited.

NO PART OF THIS SPECIFICATION MAY BE REPRODUCED OR TRANSMITTED IN ANY FORM OR BY ANY MEANS WITHOUT THE EXPRESSED WRITTEN PERMISSION OF ELAN MICROELECTRONICS.



ELAN MICROELECTRONICS CORPORATION

Headquarters:

No. 12, Innovation 1st Road
Hsinchu Science Park
Hsinchu, TAIWAN 30076
Tel: +886 3 563-9977
Fax: +886 3 563-9966
webmaster@emc.com.tw
<http://www.emc.com.tw>

Hong Kong:

Elan (HK) Microelectronics Corporation, Ltd.
Flat A, 19F., World Tech Centre 95
How Ming Street, Kwun Tong
Kowloon, HONG KONG
Tel: +852 2723-3376
Fax: +852 2723-7780

USA:

Elan Information Technology Group (U.S.A.)
PO Box 601
Cupertino, CA 95015
U.S.A.
Tel: +1 408 366-8225
Fax: +1 408 366-8225

Korea:**Elan Korea Electronics Company, Ltd.**

301 Dong-A Building
632 Kojan-Dong, Namdong-ku
Incheon City, KOREA
Tel: +82 32 814-7730
Fax: +82 32 813-7730

Shenzhen:**Elan Microelectronics Shenzhen, Ltd.**

3F, SSMEC Bldg., Gaoxin S. Ave. I
Shenzhen Hi-tech Industrial Park
(South Area), Shenzhen
CHINA 518057
Tel: +86 755 2601-0565
Fax: +86 755 2601-0500
elan-sz@elanic.com.cn

Shanghai:**Elan Microelectronics Shanghai, Ltd.**

3F, Building #13
No. 116, Lane 572, Bibo Road
Zhangjiang Hi-Tech Park
Shanghai, CHINA 201203
Tel: +86 21 5080-3866
Fax: +86 21 5080-4600
elan-sh@elanic.com.cn

Contents

1	General Description	1
1.1	Application.....	1
2	Features	1
3	Block Diagram	3
4	Pin Assignment.....	4
5	Pin Description	5
5.1	MCU System Pins (13 Pins).....	5
5.2	Embedded LCD Pins (79 Pins)	5
5.3	I/O Port (8 Pins).....	6
5.4	OTP Programming Pins (20 Pins)	6
6	Code Option	7
7	MCU System.....	9
7.1	Power-up and Reset Timing	9
7.2	MCU Operation Timing.....	10
8	ROM and RAM.....	11
8.1	Program ROM Map	11
8.2	RAM Map	11
8.2.1	Un-banked RAM.....	11
8.2.2	Banked General RAM	11
8.3	LCD RAM Map	12
9	Application Circuits.....	13
10	OTP for ePS6000.....	14
10.1	MCU Features	14
10.2	Peripheral Features.....	14
10.3	Internal Specification	15
10.4	Pin Assignment.....	15
10.5	Application Circuits.....	16

11	OTP for ePS5005	17
11.1	MCU Features	17
11.2	Peripheral Features.....	17
11.3	Internal Specification	18
11.4	Pin Assignment.....	18
11.5	Application Circuits.....	19
12	OTP for ePS6500	20
12.1	MCU Features	20
12.2	Peripheral Features.....	20
12.3	Internal Specification	21
12.4	Pin Assignment.....	21
12.5	Application Circuits.....	22
13	OTP for ePS5001	23
13.1	MCU Features	23
13.2	Peripheral Features.....	23
13.3	Internal Specification	24
13.4	Pin Assignment.....	24
13.5	Application Circuits.....	25
14	OTP for ePS5002	26
14.1	MCU Features	26
14.2	Peripheral Features.....	26
14.3	Internal Specification	27
14.4	Pin Assignment.....	27
14.5	Application Circuits.....	28
15	Electrical Characteristics	29
15.1	VDD = 1.5V Electrical Characteristics	29
15.2	VDD = 3.0V Electrical Characteristics	31

Specification Revision History

Doc. Version	Revision Description	Date
0.1	Initial Version	2007/03/21
0.2	Modified the OTP Programming Pins: added OSC1, PA.0-3 Modified the OTP Programming Pins: added PWRON	2007/04/25 2007/04/26
0.3	Modified the Pin Assignment for ePS6000, ePS5005, ePS6500, ePS6510 and ePS5001. Modified the Application Circuit: added VPP connection to VDD Modified the Block Diagram Added a comparison table for the EPS series Modified the Application Circuit: cut a capacitance between C4A & C4B when Vdd=3V Modified the Pin Assignment	2007/04/30 2007/05/08
0.4	Modified the SEG32 of the Pin Assignment for ePS6500, ePS6510 and ePS5001	2007/05/22
0.5	Modified the Pin Assignment for ePS6500, ePS6510 and ePS5001: V22 modified to V20, V07 modified to V10 Modified the Application circuit for ePS6500, ePS6510 and ePS5001: added 1/2 bias circuit Added the external Resistor value for low and high external RC oscillator	2007/06/15
0.6	Added Electrical Characteristics Deleted the ADC function Added ePS5002 to the series	2007/09/10
0.7	Modified the Electrical Characteristics	2008/05/08
0.8	Modified the Pin Assignment	2009/07/30
1.0	Modified the Operating voltage to 1.5V only for ePS5005, ePS6500, ePS5001 and ePS5002 Deleted the ePS6510	2010/11/03

Comparison Table for the EPS Series

MCU Features	ePSP6000	ePS6000	ePS5005	ePS6500	ePS5001	ePS5002
Type	OTP	Mask	Mask	Mask	Mask	Mask
Operating Voltage	1.2V ~ 3.6V	1.2V ~ 3.6V	1.2V ~1.8V	1.2V ~ 1.8V	1.2V ~ 1.8V	1.2V ~ 1.8V
High Frequency	External RC	External RC	External RC	External RC	External RC	External RC
Low Frequency	External RC/ Internal RC / Crystal	External RC/ Internal RC/ Crystal	External RC/ Internal RC/ Crystal	Internal RC/ Crystal	Internal RC/ Crystal	Internal RC/ Crystal
ROM	32K words	16K words	16K words	8K words	2K words	4K words
RAM	2K bytes	2K bytes	512 bytes	1.2K bytes	128 bytes	512 bytes
LCD	11×60	11×60	11×60	5×40	5×40	5×40
Timer	Timers 0~2	Timers 0~2	Timers 0~2	Timers 0~2	Timers 0~2	Timers 0~2
WDT	V	V	V	V	V	V
I/P	–	–	–	4 pins	4 pins	4 pins
I/O	24 pins	24 pins	24 pins	12 pins	12 pins	12 pins
ADC	–	–	–	–	–	–

1 General Description

The **ePSP6000** is an 8-bit RISC MCU embedded with an 11×60 LCD driver along with two 8-bit timers, one 16-bit general timer, event counter, and a Watchdog Timer. It also has on-chip 2K bytes RAM and 32K words program ROM. It is highly ideal for advance scientific calculator application, particularly those requiring high performance and low cost solution.

The MCU core is one of ELAN's second generation RISC based IC's, known as RISC II (RII) series. The core was specifically designed for low power and portable device applications. The ePSP6000 also supports Fast, Slow and Idle modes, as well as Sleep mode to enhance its low power consumption features.

IMPORTANT NOTES

- Do not use Register BSR (05h) Bit 7 ~ Bit 4.
- Do not use Register BSR1 (07h) Bit 7 ~ Bit 4.
- Do not use LCD RAM 3Ch ~ 3Fh.
- Do not use Register JDNZ at FSR1 (04h) special register.

1.1 Application

- Scientific calculating gadgets

2 Features

MCU

- 8 bit RISC MCU
- Operating voltage: 1.2V~3.6V
- Clock Source: Dual clock system
 - Low-frequency: 32kHz Internal RC oscillator / External RC oscillator / Crystal oscillator
 - High-frequency: 200kHz / 300kHz / 500kHz External RC oscillator

IMPORTANT NOTES

The external Resistor value of low and high external RC oscillator is shown below:

$ELRC=32.8kHz \rightarrow R=2M\Omega$.

$EHRC=200kHz \rightarrow R=1.2M\Omega$; $EHRC=300kHz \rightarrow R=820K\Omega$;

$EHRC=500kHz \rightarrow R=470K\Omega$; $EHRC=1MHz \rightarrow R=220K\Omega$.

- One Instruction cycle time = 2 × System clock time
- Program ROM addressing: 32K words maximum

- 128 bytes un-banked RAM including special registers and common registers
- 16×128 bytes banked RAM
- RAM stack has a maximum of 32 stack levels
- Look-up Table function is fast and highly efficient when combined with Repeat instruction
- Register to Register move instruction
- Compare and Branch in one instruction (2 cycles)
- Single Repeat function (maximum of 256 repeat times)
- Decimal ADD and SUB instruction
- Full range Call and Jump ability (2 cycles)

Peripheral Features

- 24 general I/O pins (Port A, Port B, Port C)
- 11/10/5/4/3 COM × 60 SEG LCD driver (embedded)
- One 16-bit timer (Timer 0) with event counter function
- One 8-bit timer (Timer 1) with wake-up function
- One 8-bit timer (Timer 2)
- One 8-bit Watchdog Timer
- Key I/O function with a maximum of 64 keys

Internal Specification

- Watchdog Timer with its own on-chip RC oscillator
- MCU operating modes: Sleep Mode, Idle Mode, Slow Mode, and Fast Mode
- Supports RC oscillation and crystal oscillation for clock system
- MCU Wake-up function consisting of input wake-up and Timer 1 wake-up
- MCU interrupt function consisting of Input port interrupt and Timer interrupt (Timers 0 ~ 2)
- MCU reset function includes power-on reset, RSTB pin reset, and Watchdog timer reset.

3 Block Diagram

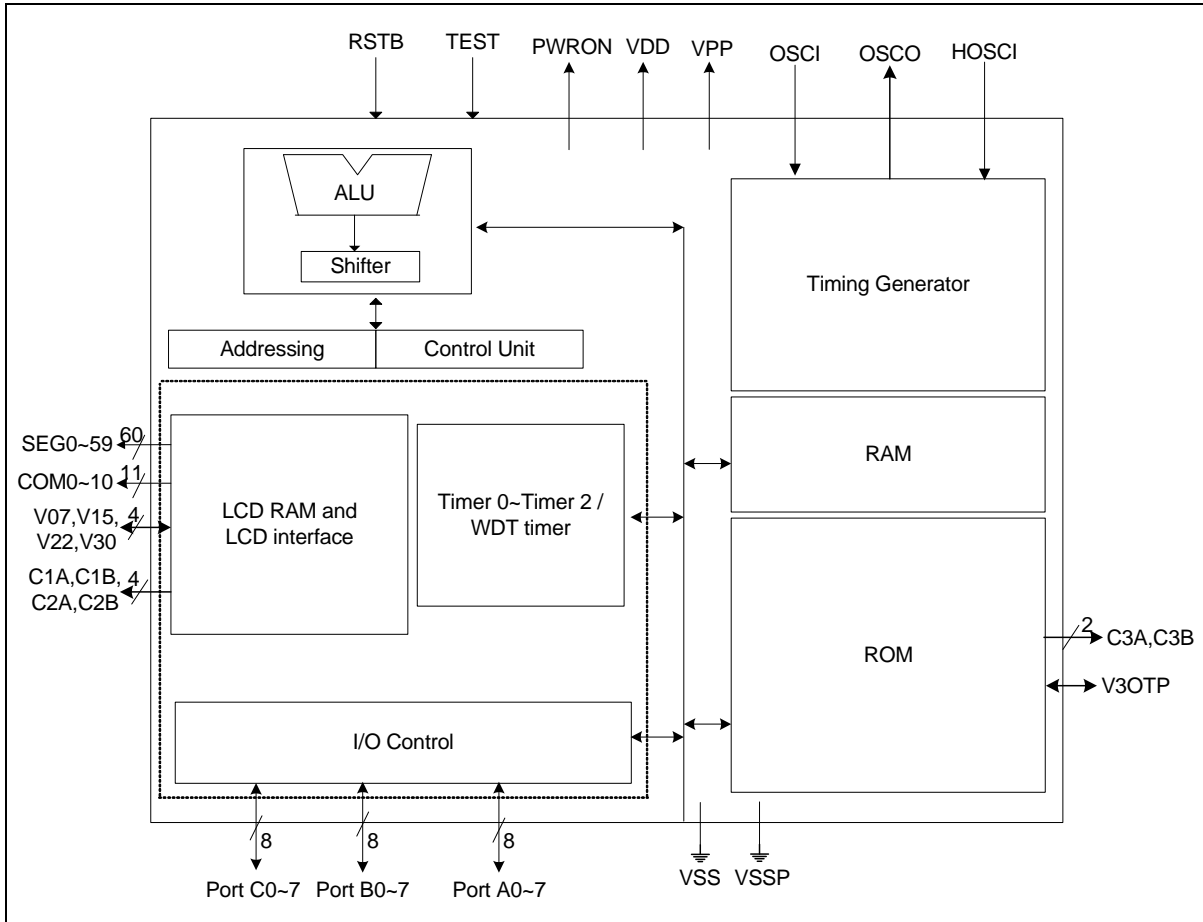
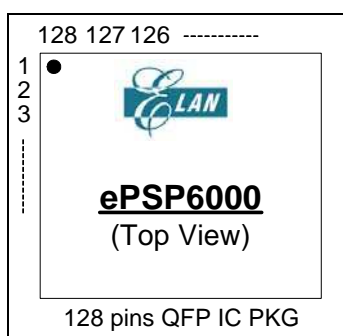

Figure 3-1 ePSP6000 Block Diagram

4 Pin Assignment



■ 100-pin Chip form

No.	Pin Name	No.	Pin Name	No.	Pin Name	No.	Pin Name
1	NC	33	SEG4/Strobe4	65	SEG25	97	SEG57/PortB.5
2	NC	34	SEG5/Strobe5	66	SEG26	98	SEG58/PortB.6
3	PortA.4	35	SEG6/Strobe6	67	SEG27	99	SEG59/PortB.7
4	PortA.5	36	SEG7/Strobe7	68	SEG28	100	NC
5	PortA.6	37	NC	69	SEG29	101	NC
6	PortA.7	38	NC	70	SEG30	102	NC
7	VPP	39	NC	71	SEG31	103	NC
8	VSSP	40	NC	72	SEG32	104	NC
9	C3A	41	NC	73	SEG33	105	NC
10	C3B	42	NC	74	SEG34	106	NC
11	V3OTP	43	NC	75	SEG35	107	NC
12	RESETB	44	NC	76	SEG36	108	PWRON
13	OSCO	45	SEG8/Strobe8	77	SEG37	109	NC
14	OSCI	46	SEG9/Strobe9	78	SEG38	110	NC
15	VDD	47	SEG10/Strobe10	79	SEG39	111	NC
16	HOSCI	48	SEG11/Strobe11	80	SEG40	112	C1A
17	VSS	49	SEG12/Strobe12	81	SEG41	113	C1B
18	COM10	50	SEG13/Strobe13	82	SEG42	114	C2A
19	COM9	51	SEG14/Strobe14	83	SEG43	115	C2B
20	COM8	52	SEG15/Strobe15	84	SEG44/PortC.0	116	V30
21	COM7	53	SEG16	85	SEG45/PortC.1	117	V22/V20
22	COM6	54	SEG17	86	SEG46/PortC.2	118	V15
23	COM5	55	SEG18	87	SEG47/PortC.3	119	V07/V10
24	COM4	56	SEG19	88	SEG48/PortC.4	120	PortA.0
25	COM3	57	SEG20	89	SEG49/PortC.5	121	PortA.1
26	COM2	58	SEG21	90	SEG50/PortC.6	122	PortA.2
27	COM1	59	SEG22	91	SEG51/PortC.7	123	PortA.3
28	COM0	60	SEG23	92	SEG52/PortB.0	124	TEST
29	SEG0/Strobe0	61	SEG24	93	SEG53/PortB.1	125	NC
30	SEG1/Strobe1	62	NC	94	SEG54/PortB.2	126	NC
31	SEG2/Strobe2	63	NC	95	SEG55/PortB.3	127	NC
32	SEG3/Strobe3	64	NC	96	SEG56/PortB.4	128	NC

5 Pin Description

5.1 MCU System Pins (13 Pins)

Name	I/O/P Type	Description	Note
VDD	P	Digital and Analog positive power supply, ranging from 1.2V~1.8V / 2.6V~3.6V. Connect to VSS through the capacitors (0.1 μ F).	–
VSS	P	Digital and Analog negative power supply.	–
RSTB	I	System reset pin. Low active.	Int. pull-up
TEST	I	Test mode select pin (High active). For chip internal test only, normally connect to VSS.	Int. Pull Down
OSCI	I	External RC oscillator / Crystal oscillator connecting pin.	Ext. R to VDD
OSCO	O	Crystal oscillator connecting pin.	–
HOSCI	I	Hi-Speed RC oscillator connecting pin.	Ext. R to VDD
PWRON	I	Connect to VSS: Operating voltage=1.5V. Connect to VDD: Operating voltage=3V.	–
VPP	P	OTP PROM Programming voltage, ranging from 0V to 12V. Connect to VDD when normally free-running.	–
VSSP	P	OTP PROM Programming negative power supply. Connect to VSS.	–
C3A, C3B	–	OTP ROM voltage charge-pump pin. Connect 0.1 μ F between C3A and C3B when VDD=1.5V.	–
V3OTP	P	OTP ROM power supply, ranging from 2.4V to 3.6V. Connect 0.1 μ F to VSS.	–

5.2 Embedded LCD Pins (79 Pins)

Name	I/O/P Type	Description	Note
COM0~COM10	O	LCD common signal output pin	–
SEG0~SEG15	O	LCD segment signal output pin shared with Key Strobe 0~15	–
SEG16~ SEG43	O	LCD segment signal output pin	–
SEG44~SEG51/ Port C.0~7	I/O	LCD segment signal output pin or I/O pin; defined by code option	–
SEG52~SEG59/ Port B.0~7	I/O	LCD segment signal output pin or I/O pin; defined by code option Port B.4~7: A/D input channels defined by code option	–
C1A, C1B	–	LCD voltage charge-pump pin. Connect 0.1 μ F between C1A and C1B.	–
C2A,C2B	–	LCD voltage charge-pump pin. Connect 0.1 μ F between C2A and C2B.	–
V30, V22, V15, V07	O	LCD bias Pin. Connect 0.1 μ F to VSS	–

5.3 I/O Port (8 Pins)

Port	Bit	Function	I/O Type	Power Source	Description	Note
Port A	Bits 3~0 (for key scan)	General Input	I	VDD	Key input	Int. Pull up (R1: small resistor, controllable R2: Large resistor)
		Interrupt and wake up	I	VDD	Input port interrupt and wake up pin	
		General Output	O	VDD	–	
	Bits 7~4	General Input	I	VDD	–	Int. Pull up (R2: controllable Large resistor)
		Interrupt and wake up	I	VDD	Input port interrupt and wake up pin	
		General Output	O	VDD	–	

5.4 OTP Programming Pins (20 Pins)

Relevant Pins for OTP Programming Mode				
Name	I/O	I/O/P Type	Description	Note
VPP	-	P	Programming voltage input.	–
VSSP	-	P	Ground	–
ACLK	PA.4	I	CLK for OTP memory address increment.	–
OEB	PA.6	I	OTP read output enable. Active low.	–
DINCK	PB.4	I	ROM code 4-bit parallel input and output clock.	–
PGM	PA.5	I	OTP program write enable. Active high.	–
DIO 0	PB.0	I/O	ROM code 4-bit parallel pin (MSB transmitted data)	–
DIO 1	PB.1	I/O	ROM code 4-bit parallel pin (MSB transmitted data)	–
DIO 2	PB.2	I/O	ROM code 4-bit parallel pin (MSB transmitted data)	–
DIO 3	PB.3	I/O	ROM code 4-bit parallel pin (MSB transmitted data)	–
TEST	–	I	Programming test input pin. Active from low to high.	–
RSTB	–	I	Programming reset input pin. Active from low to high.	–
VDD	–	P	Power supply	–
VSS	–	P	Ground	–
OSCI	OSCI	I	Programming clock input pin.	–
Port A.0~3	PA.0~3	I	Programming control input pins. PA[3:0] = 0001B.	–
PWRON	PWRON	I	Programming control input pin. Must be connected to VDD.	–

6 Code Option

Located at Address 0x000C~0x000F of Program ROM

- Initial mode after reset:
 - Select “Slow” mode or “Fast” mode

NOTE

It is recommended that user set to “Slow mode” for the Initial mode after reset.

- Operating voltage option:
 - Select “1.5V” or “3V”
- Reset pin condition:
 - Select “Level hold” or “One shot”
- Low Frequency Oscillator:
 - Select “External RC” oscillator or “Crystal” oscillator or “Internal RC” oscillator
- Maximum duty ratio option:
 - Select “1/10” duty or “1/11” duty or “1/5” duty or “1/4 duty” or “1/3 duty”
- LCD bias option:
 - Select “1/2 bias” or “1/3 bias” or “1/4 bias”
- Port B.0 control bit (SEG52):
 - Select “LCD segment signal output” or “General I/O function”
- Port B.1 control bit (SEG53):
 - Select “LCD segment signal output” or “General I/O function”
- Port B.2 control bit (SEG54):
 - Select “LCD segment signal output” or “General I/O function”
- Port B.3 control bit (SEG55):
 - Select “LCD segment signal output” or “General I/O function”
- Port B.4 control bit (SEG56):
 - Select “LCD segment signal output” or “General I/O function”

- Port B.5 control bit (SEG57):
 - Select “LCD segment signal output” or “General I/O function”
- Port B.6 control bit (SEG58):
 - Select “LCD segment signal output” or “General I/O function”
- Port B.7 control bit (SEG59):
 - Select “LCD segment signal output” or “General I/O function”
- Port C.0 control bit (SEG44):
 - Select “LCD segment signal output” or “General I/O function”
- Port C.1 control bit (SEG45):
 - Select “LCD segment signal output” or “General I/O function”
- Port C.2 control bit (SEG46):
 - Select “LCD segment signal output” or “General I/O function”
- Port C.3 control bit (SEG47):
 - Select “LCD segment signal output” or “General I/O function”
- Port C.4 control bit (SEG48):
 - Select “LCD segment signal output” or “General I/O function”
- Port C.5 control bit (SEG49):
 - Select “LCD segment signal output” or “General I/O function”
- Port C.6 control bit (SEG50):
 - Select “LCD segment signal output” or “General I/O function”
- Port C.7 control bit (SEG51):
 - Select “LCD segment signal output” or “General I/O function”

7 MCU System

7.1 Power-up and Reset Timing

■ Power-on Reset Timing:

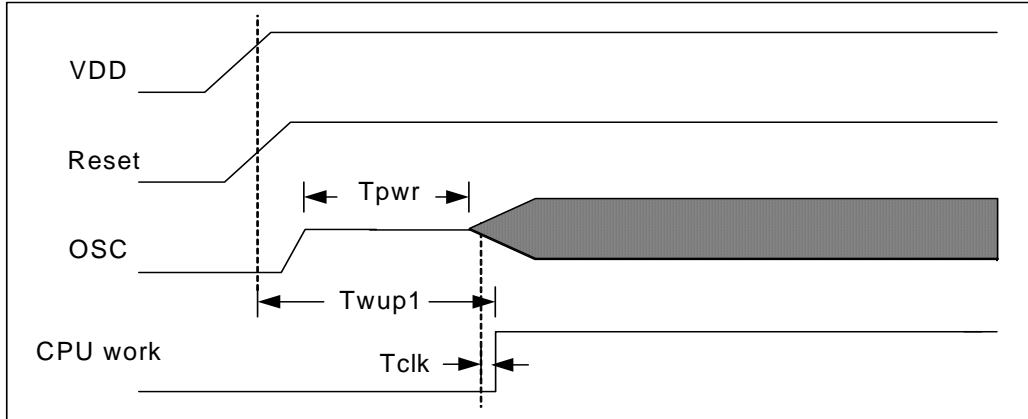

Figure 7-1 Power-on Reset Timing Diagram

■ Sleep Mode Wake-up Timing:

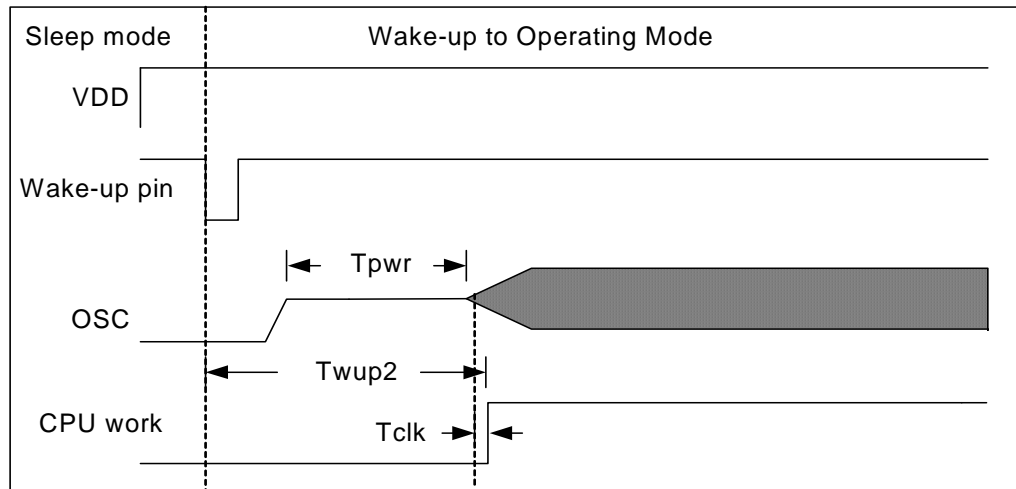

Figure 7-2 Sleep Mode Wake-up Timing Diagram

Condition: Vdd = 1.5V, Cosc = 20pF and Ta = 25°C

Symbol	Characteristics	Min.	Typ.	Max.	Unit
Tpwr	Oscillator start up time (Crystal)	-	480	780	ms
Twup1	CPU warm up time (Power-on reset)	-	500	800	ms
Twup2	CPU warm up time (Sleep mode wake-up)	-	485	785	ms
Tclk	Detect slow clock time	-	1.0	1.1	ms

7.2 MCU Operation Timing

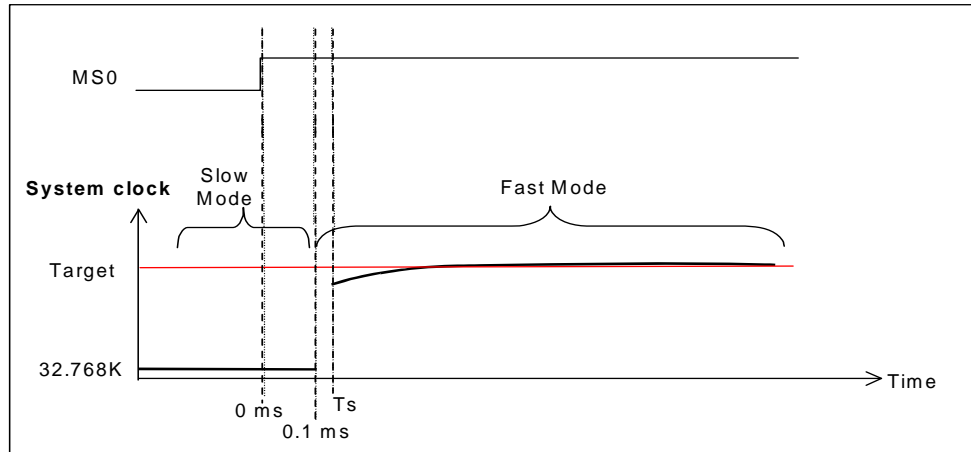

Figure 7-3 Slow Mode to Fast Mode Timing Diagram

- Note:**
1. Slow Mode switches to Fast Mode at Time=0ms.
 2. System clock will switch to Fast Mode after a delay of 0.1ms by oscillator (i.e., system clock will be at 200, 300, or 500kHz).
 3. High frequency RC will be stabilized at Time=Ts (15 μ s~30 μ s).

8 ROM and RAM

8.1 Program ROM Map

ROM Size = 32K Words	
Address	Description
0000h 000Bh	Interrupt Vector (12 words)
000Ch 000Fh	Code Option (4 words)
0010h 001Fh	Test Program (16 words)
0020h 3FFFh	0020h 3FFFh
4000h 7FFFh	Segment 2 Segment 3

8.2 RAM Map

RAM Size: 83 Bytes + 16 Banks × 128 Bytes = 2131 Bytes

8.2.1 Un-banked RAM

Address	Unbanked
00h 12h	Special Registers
13h 1Fh	General Purpose RAM
20h 39h	Control Registers
3Ah 7Fh	General Purpose RAM

8.2.2 Banked General RAM

Address	Bank 0	Bank 1	Bank 2	Bank 3	Bank 15
80h FFh	General Purpose RAM	General Purpose RAM	General Purpose RAM	General Purpose RAM	General Purpose RAM

8.3 LCD RAM Map

■ 1/3 Duty

RAM Address		COM0	COM1	COM2	-	-	-	-	-
LCDARL		Bit 0	Bit 1	Bit 2	Bit 3	Bit 4	Bit 5	Bit 6	Bit 7
SEG0	00H								
:	:								
SEG59	3BH								

■ 1/4 Duty

RAM Address		COM0	COM1	COM2	COM3	-	-	-	-
LCDARL		Bit 0	Bit 1	Bit 2	Bit 3	Bit 4	Bit 5	Bit 6	Bit 7
SEG0	00H								
:	:								
SEG59	3BH								

■ 1/5 Duty

RAM Address		COM0	COM1	COM2	COM3	COM4	-	-	-
LCDARL		Bit 0	Bit 1	Bit 2	Bit 3	Bit 4	Bit 5	Bit 6	Bit 7
SEG0	00H								
:	:								
SEG59	3BH								

■ 1/10 Duty

RAM Address		COM 0	COM 1	COM 2	COM 3	COM 4	COM 5	COM 6	COM 7
LCDARL		Bit 0	Bit 1	Bit 2	Bit 3	Bit 4	Bit 5	Bit 6	Bit 7
SEG0	00H								
:	:								
SEG59	3BH								

RAM address		COM 8	COM 9	-
LCDARL		Bit 0	Bit 1	Bit 2
SEG0	40H			
:	:			
SEG59	7BH			

■ 1/11 Duty

RAM Address		COM 0	COM 1	COM 2	COM 3	COM 4	COM 5	COM 6	COM 7
LCDARL		Bit 0	Bit 1	Bit 2	Bit 3	Bit 4	Bit 5	Bit 6	Bit 7
SEG0	00H								
:	:								
SEG59	3BH								

RAM Address		COM 8	COM 9	COM 10
LCDARL		Bit 0	Bit 1	Bit 2
SEG0	40H			
:	:			
SEG59	7BH			

9 Application Circuits

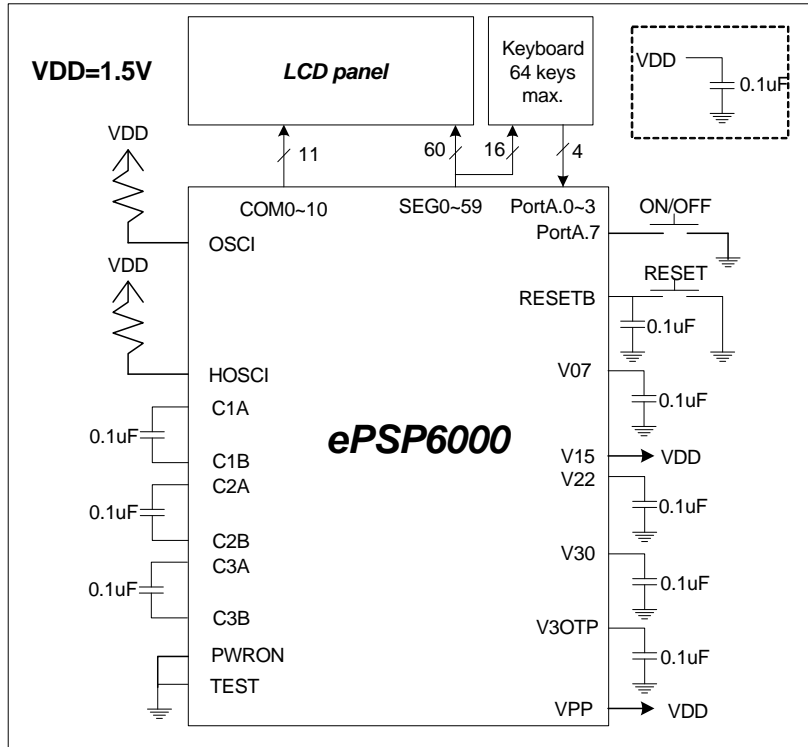

Figure 9-1 VDD=1.5V Application Circuits Diagram

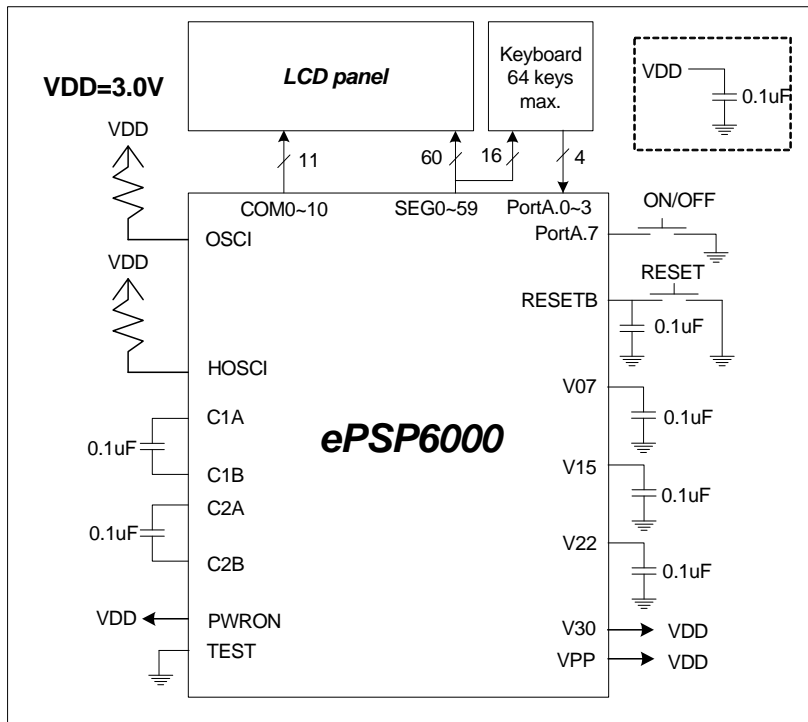

Figure 9-2 VDD=3V Application Circuits Diagram

10 OTP for ePS6000

10.1 MCU Features

- 8-bit RISC MCU
- Operating voltage: 1.2V~3.6V
- Clock Source: Dual clock system
 - Low-frequency: 32kHz Internal RC oscillator / External RC oscillator / Crystal oscillator
 - High-frequency: 200kHz / 300kHz / 500kHz External RC oscillator
- One Instruction cycle time = 2 × System clock time
- Program ROM addressing: 16K words maximum
- 128 bytes un-banked RAM including special registers and common registers
- 16×128 bytes banked RAM
- RAM stack has a maximum of 32 stack levels
- Look-up Table function is fast and highly efficient when combined with Repeat instruction
- Register-to-Register move instruction
- Compare and Branch in one instruction (2 cycles)
- Single Repeat function (maximum of 256 repeat times)
- Decimal ADD and SUB instruction
- Full range Call and Jump ability (2 cycles)

10.2 Peripheral Features

- 24 general I/O pins (Port A, Port B, Port C)
- 11/10/5 COM × 60 SEG LCD driver (embedded)
- One 16-bit timer (Timer 0)
- One 8-bit timer (Timer 1) with wake-up function
- One 8-bit timer (Timer 2)
- One 8-bit Watchdog Timer
- Key I/O function with a maximum of 64 keys

10.3 Internal Specification

- Watchdog Timer with its own on-chip RC oscillator
- MCU operating modes: Sleep Mode, Idle Mode, Slow Mode, and Fast Mode
- Supports RC oscillation and crystal oscillation for system clock
- MCU wake-up function consisting of input wake-up and Timer 1 wake-up
- MCU interrupt function consisting of Input port interrupt and Timer interrupt (Timers 0 ~ 2).
- MCU reset function includes power-on reset, RSTB pin reset, and Watchdog timer reset.

10.4 Pin Assignment

No.	Pin Name	No.	Pin Name	No.	Pin Name	No.	Pin Name
1	NC	33	SEG4/Strobe4	65	SEG25	97	SEG57/PortB.5
2	NC	34	SEG5/Strobe5	66	SEG26	98	SEG58/PortB.6
3	PortA.4	35	SEG6/Strobe6	67	SEG27	99	SEG59/PortB.7
4	PortA.5	36	SEG7/Strobe7	68	SEG28	100	NC
5	PortA.6	37	NC	69	SEG29	101	NC
6	PortA.7	38	NC	70	SEG30	102	NC
7	VPP	39	NC	71	SEG31	103	NC
8	VSSP	40	NC	72	SEG32	104	NC
9	C3A	41	NC	73	SEG33	105	NC
10	C3B	42	NC	74	SEG34	106	NC
11	V3OTP	43	NC	75	SEG35	107	NC
12	RESETB	44	NC	76	SEG36	108	PWRON
13	OSCO	45	SEG8/Strobe8	77	SEG37	109	NC
14	OSCI	46	SEG9/Strobe9	78	SEG38	110	NC
15	VDD	47	SEG10/Strobe10	79	SEG39	111	NC
16	HOSCI	48	SEG11/Strobe11	80	SEG40	112	C1A
17	VSS	49	SEG12/Strobe12	81	SEG41	113	C1B
18	COM10	50	SEG13/Strobe13	82	SEG42	114	C2A
19	COM9	51	SEG14/Strobe14	83	SEG43	115	C2B
20	COM8	52	SEG15/Strobe15	84	SEG44/PortC.0	116	V30
21	COM7	53	SEG16	85	SEG45/PortC.1	117	V22
22	COM6	54	SEG17	86	SEG46/PortC.2	118	V15
23	COM5	55	SEG18	87	SEG47/PortC.3	119	V07
24	COM4	56	SEG19	88	SEG48/PortC.4	120	PortA.0
25	COM3	57	SEG20	89	SEG49/PortC.5	121	PortA.1
26	COM2	58	SEG21	90	SEG50/PortC.6	122	PortA.2
27	COM1	59	SEG22	91	SEG51/PortC.7	123	PortA.3
28	COM0	60	SEG23	92	SEG52/PortB.0	124	TEST
29	SEG0/Strobe0	61	SEG24	93	SEG53/PortB.1	125	NC
30	SEG1/Strobe1	62	NC	94	SEG54/PortB.2	126	NC
31	SEG2/Strobe2	63	NC	95	SEG55/PortB.3	127	NC
32	SEG3/Strobe3	64	NC	96	SEG56/PortB.4	128	NC

10.5 Application Circuits

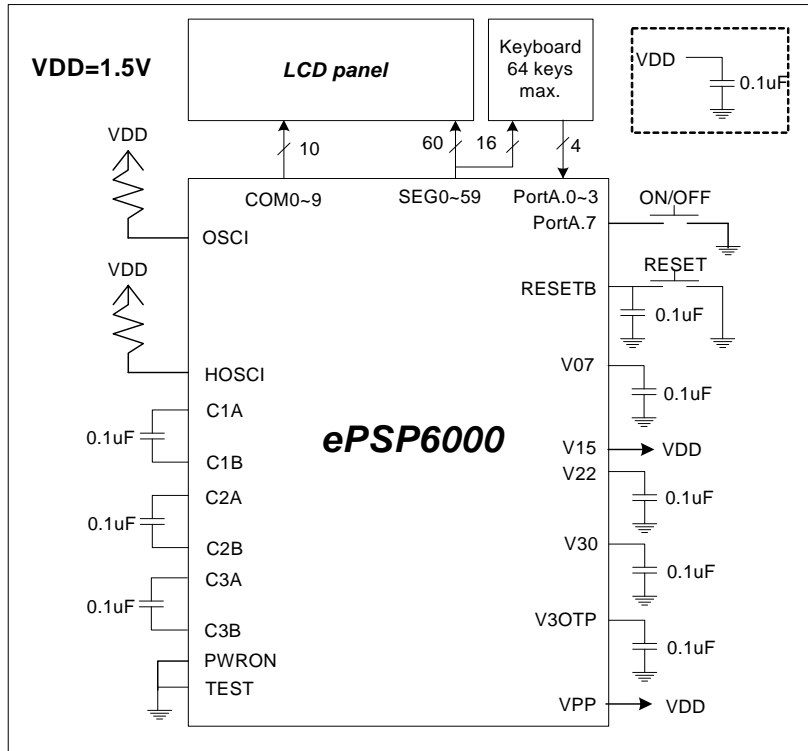

Figure 10-1 VDD=1.5V Application Circuits Diagram

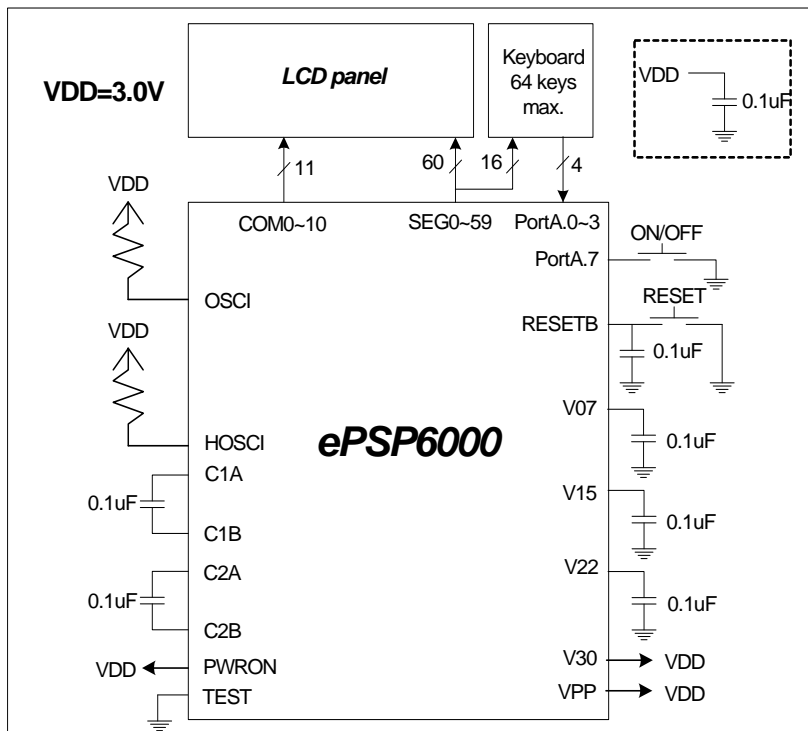

Figure 10-2 VDD=3V Application Circuits Diagram

11 OTP for ePS5005

11.1 MCU Features

- 8 bit RISC MCU
- Operating voltage: 1.2V~1.8V
- Clock Source: Dual clock system
 - Low-frequency: 32kHz Internal RC oscillator / External RC oscillator / Crystal oscillator
 - High-frequency: 200kHz / 300kHz / 500kHz External RC oscillator
- One Instruction cycle time = 2 × System clock time
- Program ROM addressing: 16K words maximum
- 128 bytes un-banked RAM including special registers and common registers
- 4×128 bytes banked RAM
- RAM stack has a maximum of 32 stack levels
- Look-up Table function is fast and highly efficient when combined with Repeat instruction
- Register-to-Register move instruction
- Compare and Branch in one instruction (2 cycles)
- Single Repeat function (maximum of 256 repeat times)
- Decimal ADD and SUB instruction
- Full range Call and Jump ability (2 cycles)

11.2 Peripheral Features

- 24 general I/O pins (Port A, Port B, Port C)
- 11/10/5 COM × 60 SEG LCD driver (embedded)
- One 16-bit timer (Timer 0)
- One 8-bit timer (Timer 1) with wake-up function
- One 8-bit timer (Timer 2)
- One 8-bit Watchdog Timer
- Key I/O function with a maximum of 64 keys

11.3 Internal Specification

- Watchdog Timer with its own on-chip RC oscillator
- MCU operating modes: Sleep Mode, Idle Mode, Slow Mode, and Fast Mode
- Supports RC oscillation and crystal oscillation for system clock
- MCU Wake-up function consisting of input wake-up and Timer 1 wake-up
- MCU interrupt function consists of Input port interrupt and Timer interrupt (Timers 0 ~ 2)
- MCU reset function includes power-on reset, RSTB pin reset, and Watchdog timer reset.

11.4 Pin Assignment

No.	Pin Name	No.	Pin Name	No.	Pin Name	No.	Pin Name
1	NC	33	SEG4/Strobe4	65	SEG25	97	SEG57/PortB.5
2	NC	34	SEG5/Strobe5	66	SEG26	98	SEG58/PortB.6
3	PortA.4	35	SEG6/Strobe6	67	SEG27	99	SEG59/PortB.7
4	PortA.5	36	SEG7/Strobe7	68	SEG28	100	NC
5	PortA.6	37	NC	69	SEG29	101	NC
6	PortA.7	38	NC	70	SEG30	102	NC
7	VPP	39	NC	71	SEG31	103	NC
8	VSSP	40	NC	72	SEG32	104	NC
9	C3A	41	NC	73	SEG33	105	NC
10	C3B	42	NC	74	SEG34	106	NC
11	V3OTP	43	NC	75	SEG35	107	NC
12	RESETB	44	NC	76	SEG36	108	PWRON
13	OSCO	45	SEG8/Strobe8	77	SEG37	109	NC
14	OSCI	46	SEG9/Strobe9	78	SEG38	110	NC
15	VDD	47	SEG10/Strobe10	79	SEG39	111	NC
16	HOSCI	48	SEG11/Strobe11	80	SEG40	112	C1A
17	VSS	49	SEG12/Strobe12	81	SEG41	113	C1B
18	COM10	50	SEG13/Strobe13	82	SEG42	114	C2A
19	COM9	51	SEG14/Strobe14	83	SEG43	115	C2B
20	COM8	52	SEG15/Strobe15	84	SEG44/PortC.0	116	V30
21	COM7	53	SEG16	85	SEG45/PortC.1	117	V22
22	COM6	54	SEG17	86	SEG46/PortC.2	118	V15
23	COM5	55	SEG18	87	SEG47/PortC.3	119	V07
24	COM4	56	SEG19	88	SEG48/PortC.4	120	PortA.0
25	COM3	57	SEG20	89	SEG49/PortC.5	121	PortA.1
26	COM2	58	SEG21	90	SEG50/PortC.6	122	PortA.2
27	COM1	59	SEG22	91	SEG51/PortC.7	123	PortA.3
28	COM0	60	SEG23	92	SEG52/PortB.0	124	TEST
29	SEG0/Strobe0	61	SEG24	93	SEG53/PortB.1	125	NC
30	SEG1/Strobe1	62	NC	94	SEG54/PortB.2	126	NC
31	SEG2/Strobe2	63	NC	95	SEG55/PortB.3	127	NC
32	SEG3/Strobe3	64	NC	96	SEG56/PortB.4	128	NC

11.5 Application Circuits

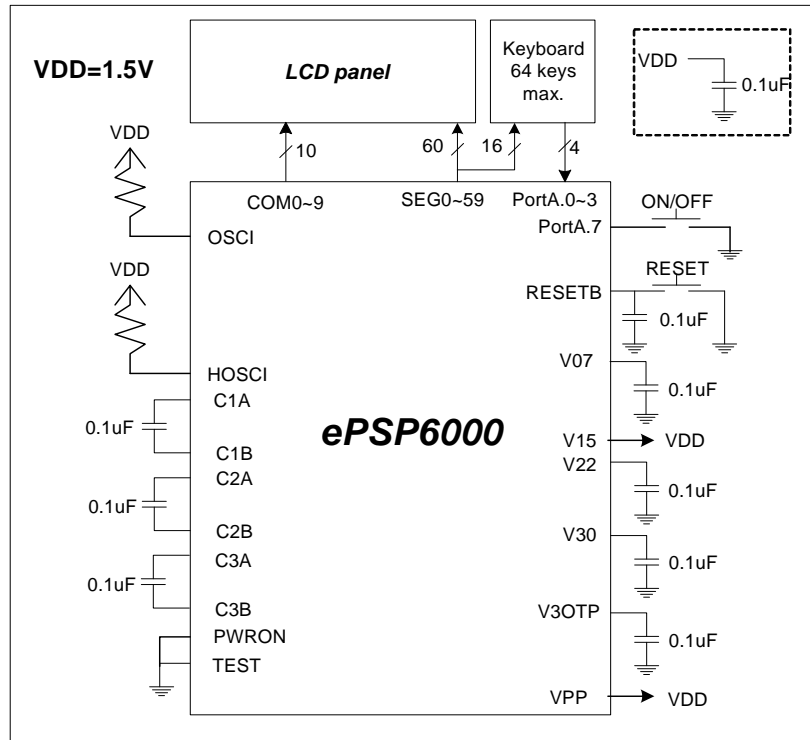

Figure 11-1 VDD=1.5V Application Circuits Diagram

12 OTP for ePS6500

12.1 MCU Features

- 8-bit RISC MCU
- Operating voltage: 1.2V~1.8V
- Clock Source: Dual clock system
 - Low-frequency: 32kHz Internal RC oscillator / Crystal oscillator
 - High-frequency: 200kHz / 300kHz / 500kHz External RC oscillator
- One Instruction cycle time = 2 × System clock time
- Program ROM addressing: 8K words maximum
- 128 bytes un-banked RAM including special registers and common registers
- 10×128 bytes banked RAM
- RAM stack has a maximum of 32 stack levels
- Look-up Table function is fast and highly efficient when combined with Repeat instruction
- Register-to-Register move instruction
- Compare and Branch in one instruction (2 cycles)
- Single Repeat function (maximum of 256 repeat times)
- Decimal ADD and SUB instruction
- Full range CALL and JUMP ability (2 cycles)

12.2 Peripheral Features

- 16 general I/O pins (Port A, Port B)
- 5/4/3 COM × 40 SEG LCD driver (embedded)
- One 16-bit timer (Timer 0) with event counter function
- One 8-bit timer (Timer 1) with wake-up function
- One 8-bit timer (Timer 2)
- One 8-bit Watchdog Timer
- Key I/O function with a maximum of 64 keys

12.3 Internal Specification

- Watchdog Timer with its own on-chip RC oscillator
- MCU operating modes: Sleep Mode, Idle Mode, Slow Mode, and Fast Mode
- Supports RC oscillation and crystal oscillation for system clock
- MCU wake-up function consisting of input wake-up and Timer 1 wake-up
- MCU interrupt function consisting of Input port interrupt and Timer interrupt (Timers 0 ~ 2).
- MCU reset function includes power-on reset, RSTB pin reset, and Watchdog timer reset.

12.4 Pin Assignment

No.	Pin Name	No.	Pin Name	No.	Pin Name	No.	Pin Name
1	NC	33	SEG4/Strobe4	65	SEG25	97	SEG37/PortB.5
2	NC	34	SEG5/Strobe5	66	SEG26	98	SEG38/PortB.6
3	PortA.4	35	SEG6/Strobe6	67	SEG27	99	SEG39/PortB.7 (EVIN)
4	PortA.5	36	SEG7/Strobe7	68	SEG28	100	NC
5	PortA.6	37	NC	69	SEG29	101	NC
6	PortA.7	38	NC	70	SEG30	102	NC
7	VPP	39	NC	71	SEG31	103	NC
8	VSSP	40	NC	72	NC	104	NC
9	C3A	41	NC	73	NC	105	NC
10	C3B	42	NC	74	NC	106	NC
11	V3OTP	43	NC	75	NC	107	NC
12	RESETB	44	NC	76	NC	108	PWRON
13	OSCO	45	SEG8/Strobe8	77	NC	109	NC
14	OSCI	46	SEG9/Strobe9	78	NC	110	NC
15	VDD	47	SEG10/Strobe10	79	NC	111	NC
16	HOSCI	48	SEG11/Strobe11	80	NC	112	C1A
17	VSS	49	SEG12/Strobe12	81	NC	113	C1B
18	NC	50	SEG13/Strobe13	82	NC	114	C2A
19	NC	51	SEG14/Strobe14	83	NC	115	C2B
20	NC	52	SEG15/Strobe15	84	NC	116	V30
21	NC	53	SEG16	85	NC	117	V20
22	NC	54	SEG17	86	NC	118	V15
23	NC	55	SEG18	87	NC	119	V10
24	COM4	56	SEG19	88	NC	120	PortA.0
25	COM3	57	SEG20	89	NC	121	PortA.1
26	COM2	58	SEG21	90	NC	122	PortA.2
27	COM1	59	SEG22	91	NC	123	PortA.3
28	COM0	60	SEG23	92	SEG32/PortB.0	124	TEST
29	SEG0/Strobe0	61	SEG24	93	SEG33/PortB.1	125	NC
30	SEG1/Strobe1	62	NC	94	SEG34/PortB.2	126	NC
31	SEG2/Strobe2	63	NC	95	SEG35/PortB.3	127	NC
32	SEG3/Strobe3	64	NC	96	SEG36/PortB.4	128	NC

12.5 Application Circuits

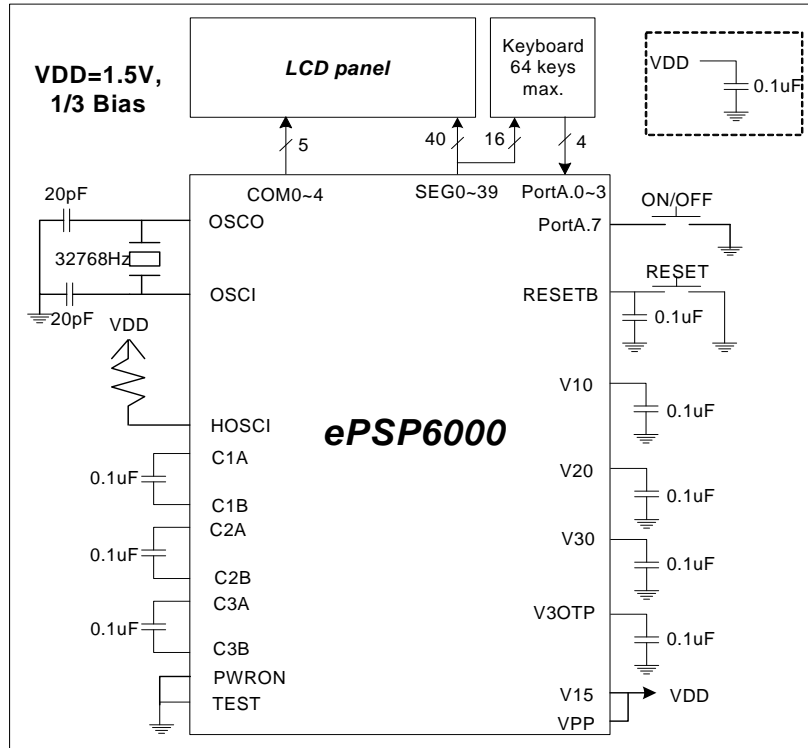

Figure 12-1 VDD=1.5V and 1/3 Bias Application Circuits Diagram

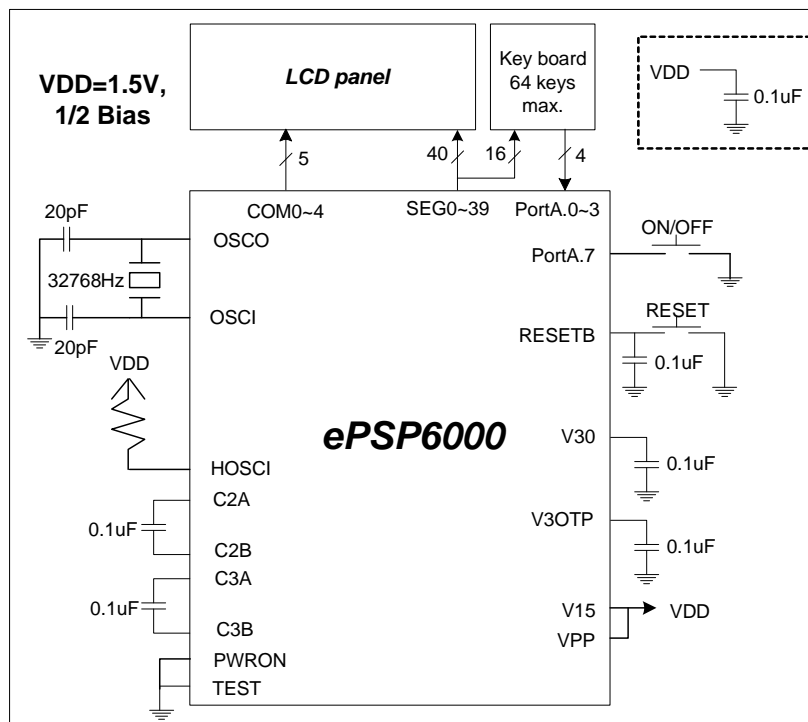

Figure 12-2 VDD=1.5V and 1/2 Bias Application Circuit Diagram

13 OTP for ePS5001

13.1 MCU Features

- 8-bit RISC MCU
- Operating voltage: 1.2V~1.8V
- Clock Source: Dual clock system
 - Low-frequency: 32kHz Internal RC oscillator /Crystal oscillator
 - High-frequency:200kHz / 300kHz / 500kHz External RC oscillator
- One Instruction cycle time = 2 × System clock time
- Program ROM addressing: maximum of 2K words
- 128 bytes un-banked RAM including special registers and common registers
- 1×128 bytes banked RAM
- RAM stack has a maximum of 32 stack levels
- Look-up Table function is fast and highly efficient when combined with Repeat instruction
- Register-to-Register move instruction
- Compare and Branch in one instruction (2 cycles)
- Single Repeat function (maximum of 256 repeat times)
- Decimal ADD and SUB instruction
- Full range Call and Jump ability (2 cycles)

13.2 Peripheral Features

- 16 general I/O pins (Port A, Port B)
- 5/4/3 COM × 40 SEG LCD driver (embedded)
- One 16-bit timer (Timer 0) with event counter function
- One 8-bit timer (Timer 1) with wake-up function
- One 8-bit timer (Timer 2)
- One 8-bit Watchdog Timer
- Key I/O function with a maximum of 64 keys

13.3 Internal Specification

- Watchdog Timer with its own on-chip RC oscillator
- MCU operating modes: Sleep Mode, Idle Mode, Slow Mode, and Fast Mode
- Supports RC oscillation and crystal oscillation for system clock
- MCU wake-up function consisting of input wake-up and Timer 1 wake-up
- MCU interrupt function consisting of Input port interrupt and Timer interrupt (Timers 0 ~ 2).
- MCU reset function includes power-on reset, RSTB pin reset, and Watchdog timer reset.

13.4 Pin Assignment

No.	Pin Name	No.	Pin Name	No.	Pin Name	No.	Pin Name
1	NC	33	SEG4/Strobe4	65	SEG25	97	SEG37/PortB.5
2	NC	34	SEG5/Strobe5	66	SEG26	98	SEG38/PortB.6
3	PortA.4	35	SEG6/Strobe6	67	SEG27	99	SEG39/PortB.7 (EVIN)
4	PortA.5	36	SEG7/Strobe7	68	SEG28	100	NC
5	PortA.6	37	NC	69	SEG29	101	NC
6	PortA.7	38	NC	70	SEG30	102	NC
7	VPP	39	NC	71	SEG31	103	NC
8	VSSP	40	NC	72	NC	104	NC
9	C3A	41	NC	73	NC	105	NC
10	C3B	42	NC	74	NC	106	NC
11	V3OTP	43	NC	75	NC	107	NC
12	RESETB	44	NC	76	NC	108	PWRON
13	OSCO	45	SEG8/Strobe8	77	NC	109	NC
14	OSCI	46	SEG9/Strobe9	78	NC	110	NC
15	VDD	47	SEG10/Strobe10	79	NC	111	NC
16	HOSCI	48	SEG11/Strobe11	80	NC	112	C1A
17	VSS	49	SEG12/Strobe12	81	NC	113	C1B
18	NC	50	SEG13/Strobe13	82	NC	114	C2A
19	NC	51	SEG14/Strobe14	83	NC	115	C2B
20	NC	52	SEG15/Strobe15	84	NC	116	V30
21	NC	53	SEG16	85	NC	117	V20
22	NC	54	SEG17	86	NC	118	V15
23	NC	55	SEG18	87	NC	119	V10
24	COM4	56	SEG19	88	NC	120	PortA.0
25	COM3	57	SEG20	89	NC	121	PortA.1
26	COM2	58	SEG21	90	NC	122	PortA.2
27	COM1	59	SEG22	91	NC	123	PortA.3
28	COM0	60	SEG23	92	SEG32/PortB.0	124	TEST
29	SEG0/Strobe0	61	SEG24	93	SEG33/PortB.1	125	NC
30	SEG1/Strobe1	62	NC	94	SEG34/PortB.2	126	NC
31	SEG2/Strobe2	63	NC	95	SEG35/PortB.3	127	NC
32	SEG3/Strobe3	64	NC	96	SEG36/PortB.4	128	NC

13.5 Application Circuits

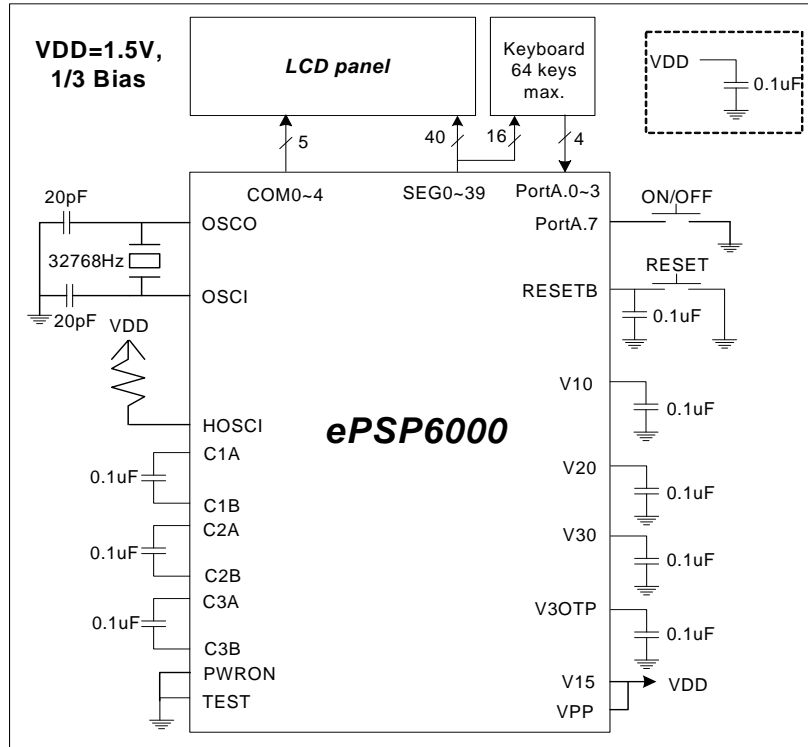

Figure 13-1 VDD=1.5V and 1/3 Bias Application Circuits Diagram

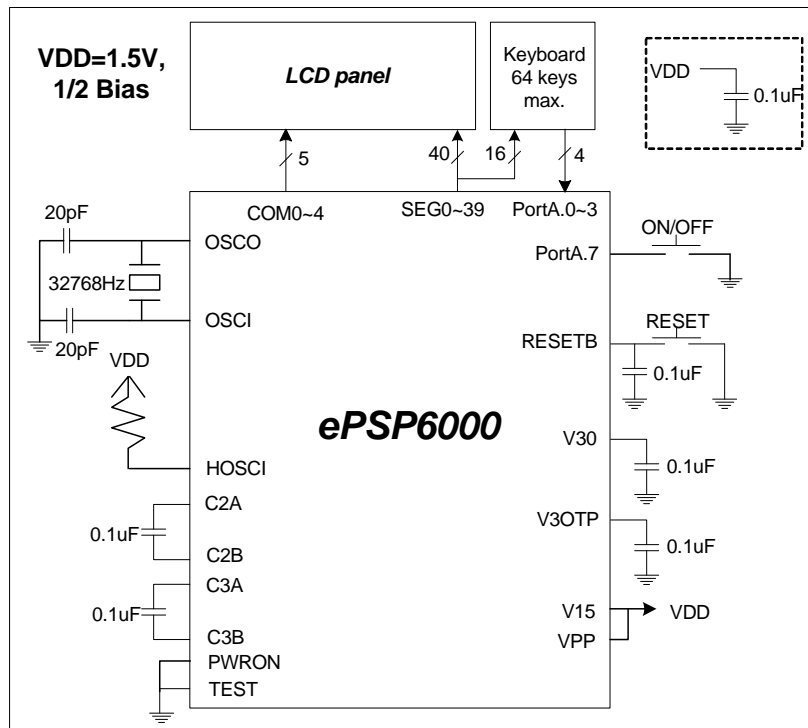

Figure 13-2 VDD=1.5V and 1/2 Bias Application Circuits Diagram

14 OTP for ePS5002

14.1 MCU Features

- 8-bit RISC MCU
- Operating voltage: 1.2V~1.8V
- Clock Source: Dual clock system
 - Low-frequency: 32kHz Internal RC oscillator / Crystal oscillator
 - High-frequency: 200kHz / 300kHz / 500kHz External RC oscillator
- One Instruction cycle time = $2 \times$ System clock time
- Program ROM addressing: maximum of 4K words
- 128 bytes un-banked RAM including special registers and common registers
- 4×128 bytes banked RAM
- RAM stack has a maximum of 32 stack levels
- Look-up Table function is fast and highly efficient when combined with Repeat instruction
- Register-to-Register move instruction
- Compare and Branch in one instruction (2 cycles)
- Single Repeat function (maximum of 256 repeat times)
- Decimal ADD and SUB instruction
- Full range Call and Jump ability (2 cycles)

14.2 Peripheral Features

- 16 general I/O pins (Port A, Port B)
- 5/4/3 COM × 40 SEG LCD driver (embedded)
- One 16-bit timer (Timer 0) with event counter function
- One 8-bit timer (Timer 1) with wake-up function
- One 8-bit timer (Timer 2)
- One 8-bit Watchdog Timer
- Key I/O function with a maximum of 64 keys

14.3 Internal Specification

- Watchdog Timer with its own on-chip RC oscillator
- MCU operating modes: Sleep Mode, Idle Mode, Slow Mode, and Fast Mode
- Supports RC oscillation and crystal oscillation for system clock
- MCU wake-up function consisting of input wake-up and Timer 1 wake-up
- MCU interrupt function consisting of Input port interrupt and Timer interrupt (Timers 0 ~ 2).

MCU reset function includes power-on reset, RSTB pin reset, and Watchdog timer reset.

14.4 Pin Assignment

No.	Pin Name	No.	Pin Name	No.	Pin Name	No.	Pin Name
1	NC	33	SEG4/Strobe4	65	SEG25	97	SEG37/PortB.5
2	NC	34	SEG5/Strobe5	66	SEG26	98	SEG38/PortB.6
3	PortA.4	35	SEG6/Strobe6	67	SEG27	99	SEG39/PortB.7 (EVIN)
4	PortA.5	36	SEG7/Strobe7	68	SEG28	100	NC
5	PortA.6	37	NC	69	SEG29	101	NC
6	PortA.7	38	NC	70	SEG30	102	NC
7	VPP	39	NC	71	SEG31	103	NC
8	VSSP	40	NC	72	NC	104	NC
9	C3A	41	NC	73	NC	105	NC
10	C3B	42	NC	74	NC	106	NC
11	V3OTP	43	NC	75	NC	107	NC
12	RESETB	44	NC	76	NC	108	PWRON
13	OSCO	45	SEG8/Strobe8	77	NC	109	NC
14	OSCI	46	SEG9/Strobe9	78	NC	110	NC
15	VDD	47	SEG10/Strobe10	79	NC	111	NC
16	HOSCI	48	SEG11/Strobe11	80	NC	112	C1A
17	VSS	49	SEG12/Strobe12	81	NC	113	C1B
18	NC	50	SEG13/Strobe13	82	NC	114	C2A
19	NC	51	SEG14/Strobe14	83	NC	115	C2B
20	NC	52	SEG15/Strobe15	84	NC	116	V30
21	NC	53	SEG16	85	NC	117	V20
22	NC	54	SEG17	86	NC	118	V15
23	NC	55	SEG18	87	NC	119	V10
24	COM4	56	SEG19	88	NC	120	PortA.0
25	COM3	57	SEG20	89	NC	121	PortA.1
26	COM2	58	SEG21	90	NC	122	PortA.2
27	COM1	59	SEG22	91	NC	123	PortA.3
28	COM0	60	SEG23	92	SEG32/PortB.0	124	TEST
29	SEG0/Strobe0	61	SEG24	93	SEG33/PortB.1	125	NC
30	SEG1/Strobe1	62	NC	94	SEG34/PortB.2	126	NC
31	SEG2/Strobe2	63	NC	95	SEG35/PortB.3	127	NC
32	SEG3/Strobe3	64	NC	96	SEG36/PortB.4	128	NC

14.5 Application Circuits

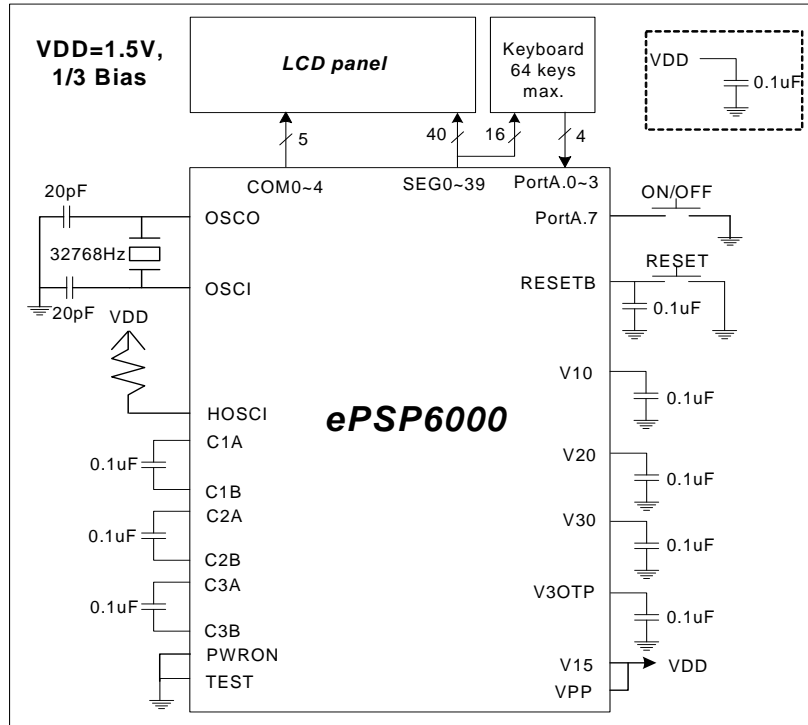

Figure 14-1 VDD=1.5V and 1/3 Bias Application Circuits Diagram

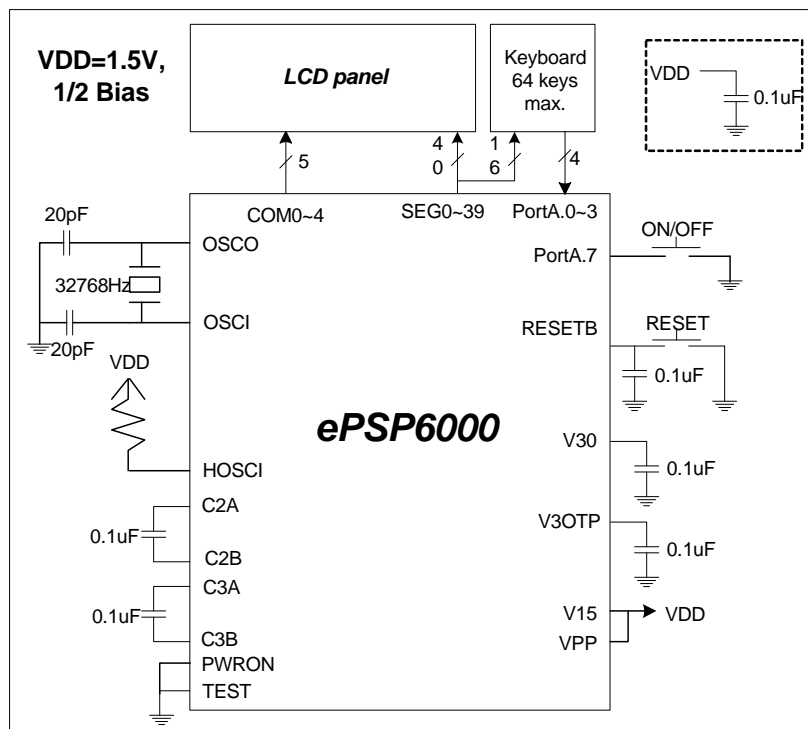

Figure 14-2 VDD=1.5V and 1/2 Bias Application Circuits Diagram

15 Electrical Characteristics

15.1 VDD = 1.5V Electrical Characteristics

■ **Absolute Maximum Ratings**

Items	Sym.	Condition	Limits	Unit
Supply voltage	VDD	–	–0.3 to +2.0	V
Supply voltage for ICE	VCC	–	–0.3 to +3.6	
Input voltage (general input port)	VIN	–	–0.5 to VDD +0.5	V
Input voltage for ICE	VIN1	–	–0.5 to VCC +0.5	V
Operating temperature range	TOPR	–	–10 to +70	°C
Storage temperature range	TSTR	–	–55 to +125	°C

■ **Recommended Operating Conditions**

Items	Sym.	Condition	Limits	Unit
Supply voltage	VDD	–	1.2 to 1.8	V
Supply voltage for ICE	VCC	–	2.2 to 3.6	
Input voltage	VIH	–	VDD x 0.9 to VDD	V
	VIL	–	0 to VDD x 0.1	V
Input voltage for ICE	VIH	–	VDD x 0.9 to VDD	V
	VIL	–	0 to VDD x 0.1	V
Operating temperature	TOPR	–	–10 to +70	°C

■ **DC Electrical Characteristics (Condition: Ta=25°C, VDD= 1.5V)**

Parameter	Sym.	Condition		Min.	Typ.	Max.	Unit
Clock	F _{HOSC}	Main-clock frequency	RC OSC. R=1.2MΩ	140	200	260	kHz
			RC OSC. R=820KΩ	210	300	390	
			RC OSC. R=470KΩ	350	500	650	
			RC OSC. R=220KΩ	700	1000	1300	
	F _{OSC}	Sub-clock frequency	Internal RC OSC.	24.6	32.8	41	kHz
			External RC OSC. R=2MΩ	24.6	32.8	41	
Crystal OSC.			-	32.768	-		
Supply Current	I _{dd1}	Sleep mode	VDD=1.5V, no load	-	-	3	μA
	I _{dd2}	Idle mode	VDD=1.5V RC OSC, LCD disabled, no load	-	4	8	
	I _{dd3}		VDD=1.5V RC OSC, LCD enabled, no load	-	4	8	
	I _{dd4}		VDD=1.5V, X'tal OSC, LCD disabled, no load	-	3	6	
	I _{dd5}		VDD=1.5V, X'tal OSC, LCD enabled, no load	-	3	6	
	I _{dd6}		Slow mode	VDD=1.5V, RC/X'tal OSC, LCD disabled, no load	-	5	
	I _{dd7}	Slow mode	VDD=1.5V, RC/X'tal OSC, LCD enabled, no load	-	5	10	
	I _{dd8-11}	Fast mode	VDD=1.5V, F _{HOSC} =200kHz, LCD enabled, no load	-	16	32	
			VDD=1.5V, F _{HOSC} =300kHz, LCD enabled, no load	-	20	40	
			VDD=1.5V, F _{HOSC} =500kHz, LCD enabled, no load	-	30	50	
			VDD=1.5V, F _{HOSC} =1MHz, LCD enabled, no load	-	70	100	

Parameter	Sym.	Condition		Min.	Typ.	Max.	Unit
Input Voltage	VIH1	PA[0:7] , PB[0:7] (as general input port)		VDD×0.7	-	VDD	V
	VIL1			0	-	VDD×0.3	
Input Threshold Voltage (Schmitt)	VT+	RSTB		0.5×VDD	-	0.75×VDD	V
	VT-			0.2×VDD	-	0.4×VDD	
Input Leakage Current	IIL	All Input port (without pull up/down resistor) Vin= VDD or GND		-	-	± 1	μA
Large Pull-up Resistance	RPU5	RSTB	Vin=GND	300	450	800	KΩ
Small Pull-up Resistance	RPU6	RSTB	Vin=1V	10	30	60	KΩ
Large Pull-down Resistance	RPD1	TEST	Vin=VDD	250	500	800	KΩ
Small Pull-down Resistance	RPD2	TEST	Vin=0.5V	3	6	12	KΩ
Data Retention Voltage	Vret	-		1.2	-	-	V
Output Current	IOH1	PA[4:7], PB[0:7]	VDD=1.5V, VOH=1.2V, LCD enabled	-0.1	-0.4	-0.8	mA
	IOL1	(as general output port)	VDD=1.5V, VOL=0.2V, LCD enabled	0.6	0.9	1.5	
Large Pull-up Resistance	RPU1	PA[0:7]	Key high resistance, pulled-up by R2, LCD enabled, Vin2=0.5V	110	280	800	KΩ
	RPU3	PB[0:7]	Vin=0.5V, LCD enabled	100	320	800	
Small Pull-up Resistance	RPU2	PA[0:3]	Key high resistance, pulled-up by R2//R1, LCD enabled, Vin2=0 V	6	18	60	KΩ
	RPU4	PA[4:7]	Vin=1V, LCD enabled	15	30	75	
LCD Driver							
LCD Display Output On-resistance	ROC	Com[0:4]	VOH=V30 ± 0.2V	0.35	0.4	0.5	KΩ
			VOM=V20 ± 0.2V	0.55	0.65	0.75	
			VOM=V10 ± 0.2V	0.35	0.40	0.45	
			VOL=0.2V	0.25	0.3	0.35	
	ROS	Seg[0:39]	VOH=V30 ± 0.2V	0.35	0.4	0.5	KΩ
			VOM=V15 ± 0.2V	0.45	0.6	0.85	
VOL=0.1V			0.25	0.3	0.35		
Strobe Output On-resistance	ROP	Seg[0:15]	V=VDD-0.2V	80	200	500	KΩ
	RON	(as key strobe)	V=0.2V	0.7	1.3	2	

15.2 VDD = 3.0V Electrical Characteristics

■ Absolute Maximum Ratings

Items	Sym.	Condition	Limits	Unit
Supply voltage	VDD	-	-0.3 to +3.6	V
Supply voltage for ICE	VCC	-	-0.3 to +3.6	V
Input voltage (general input port)	VIN	-	-0.5 to VDD +0.5	V
Input voltage for ICE	VIN1	-	-0.5 to VCC +0.5	V
Operating temperature range	TOPR	-	-10 to +70	°C
Storage temperature range	TSTR	-	-55 to +125	°C

■ Recommended Operating Conditions

Items	Sym.	Condition	Limits	Unit
Supply voltage	VDD	-	2.6 to 3.6	V
Supply voltage for ICE	VCC	-	2.2 to 3.6	
Input voltage	VIH	-	VDD x 0.9 to VDD	V
	VIL	-	0 to VDD x 0.1	V
Input voltage for ICE	VIH	-	VDD x 0.9 to VDD	V
	VIL	-	0 to VDD x 0.1	V
Operating temperature	TOPR	-	-10 to +70	°C

■ DC Electrical Characteristics (Condition: Ta = 25°C, VDD = 3.0V)

Parameter	Sym.	Condition	Min.	Typ.	Max.	Unit	
Clock	F _{HOSC}	Main-clock frequency	RC OSC. R=1.2MΩ	140	200	260	kHz
			RC OSC. R=820KΩ	210	300	390	
			RC OSC. R=470KΩ	350	500	650	
			RC OSC. R=220KΩ	700	1000	1300	
	F _{osc}	Sub-clock frequency	Internal RC OSC.	24.6	32.8	41	kHz
			External RC OSC. R=2MΩ	24.6	32.8	41	
Crystal OSC.			-	32.768	-		
Supply Current	I _{dd1}	Sleep mode	VDD=3.0V, no load	-	-	10	μA
	I _{dd2}	Idle mode	VDD=3.0V RC OSC, LCD disabled, no load	-	8	18	
	I _{dd3}		VDD=3.0V RC OSC, LCD enabled, no load	-	8	18	
	I _{dd4}		VDD=3.0V, Crystal OSC, LCD disabled, no load	-	7	16	
	I _{dd5}		VDD=3.0V, Crystal OSC, LCD enabled, no load	-	7	16	
	I _{dd6}	Slow mode	VDD=3.0V, RC/Crystal OSC, LCD disabled, no load	-	12	24	
	I _{dd7}		VDD=3.0V, RC/Crystal OSC, LCD enabled, no load	-	12	24	
	I _{dd8}	Fast mode	VDD=3.0V, FHOSC =200kHz, LCD enabled, no load	-	40	60	
	I _{dd9}		VDD=3.0V, FHOSC =300kHz, LCD enabled, no load	-	50	70	
	I _{dd10}		VDD=3.0V, FHOSC =500kHz, LCD enabled, no load	-	75	100	
	I _{dd11}		VDD=3.0V, FHOSC =1MHz, LCD enabled, no load	-	150	200	

Parameter	Sym.	Condition	Min.	Typ.	Max.	Unit	
Input Voltage	VIH1	PA[0:7] , PB[0:7], PC[0:7] (as general input port)	VDDx0.7	-	VDD	V	
	VIL1		0	-	VDDx0.3		
Input Threshold Voltage (Schmitt)	VT+	RSTB	0.5xVDD	-	0.75xVDD	V	
	VT-		0.2xVDD	-	0.4xVDD		
Input Leakage Current	IIL	All Input port (without pull up/down resistor) Vin= VDD or GND	-	-	±1	µA	
Output Current	IOH1	PA[4:7], PB[0:7] (as general output port)	VDD=3V, VOH=2.7V	-1.4	-2.2	-3	mA
	IOL1		VDD=3V, VOL=0.2V	1.2	1.6	2.2	
Large Pull-up Resistance	RPU1	PA[0:7]	Key high resistance, pulled-up by R2, LCD enabled, Vin2=0.5V	12	20	30	KΩ
	RPU3	PB[0:7], PC[0:7]	Vin = 0.5V	18	27	38	
	RPU5	RSTB	Vin = GND	60	100	150	
Small Pull-up Resistance	RPU2	PA[0:3]	Key high resistance, pulled up by R2//R1, LCD enable, Vin2=0 V	1.8	2.2	2.8	KΩ
	RPU4	PA[4:7]	Vin = 1V, LCD enabled	2	2.3	2.6	
	RPU6	RSTB	Vin = 2V	5	9	13	
Large Pull-down Resistance	RPD1	TEST	Vin = VDD	110	160	220	KΩ
Small Pull-down Resistance	RPD2	TEST	Vin = 1V	3	6	12	KΩ
Data Retention Voltage	Vret	-	2.1	-	-	V	
Power-on Reset Voltage	Vpor	-	1.6	1.8	2.0	V	
LCD Driver							
LCD Display Output On-resistance	ROC	Com[0:10]	VOH=V30 ± 0.1V	0.35	0.4	0.5	KΩ
			VOM=V20 ± 0.1V	0.55	0.65	0.75	
			VOM=V10 ± 0.1V	0.35	0.40	0.45	
			VOL=0.1V	0.25	0.3	0.35	
	ROS	Seg[0:59]	VOH=V30 ± 0.1V	0.35	0.4	0.5	KΩ
			VOM=V15 ± 0.1V	0.45	0.6	0.85	
VOL=0.1V			0.25	0.3	0.35		
Strobe Output On-resistance	ROP	Seg[0:15]	V=VDD-0.2V	16	24	32	KΩ
	RON	(as key strobe)	V=0.2V	0.45	0.6	0.8	