

---

**ePS7100**

**RISC II Series  
Microcontroller**

**Product  
Specification**

**DOC. VERSION 1.0**

**ELAN MICROELECTRONICS CORP.**

June 2013

---



---

**Trademark Acknowledgments:**

IBM is a registered trademark and PS/2 is a trademark of IBM.  
Windows is a trademark of Microsoft Corporation.

ELAN and ELAN logo  are trademarks of ELAN Microelectronics Corporation.

Copyright © 2010~2013 by **ELAN Microelectronics Corporation**

**All Rights Reserved**

Printed in Taiwan

The contents of this specification are subject to change without further notice. ELAN Microelectronics assumes no responsibility concerning the accuracy, adequacy, or completeness of this specification. ELAN Microelectronics makes no commitment to update, or to keep current the information and material contained in this specification. Such information and material may change to conform to each confirmed order.

In no event shall ELAN Microelectronics be made responsible for any claims attributed to errors, omissions, or other inaccuracies in the information or material contained in this specification. ELAN Microelectronics shall not be liable for direct, indirect, special incidental, or consequential damages arising from the use of such information or material.

The software (if any) described in this specification is furnished under a license or nondisclosure agreement, and may be used or copied only in accordance with the terms of such agreement.

ELAN Microelectronics products are not intended for use in life support appliances, devices, or systems. Use of ELAN Microelectronics product in such applications is not supported and is prohibited.

NO PART OF THIS SPECIFICATION MAY BE REPRODUCED OR TRANSMITTED IN ANY FORM OR BY ANY MEANS WITHOUT THE EXPRESSED WRITTEN PERMISSION OF ELAN MICROELECTRONICS.



---

**ELAN MICROELECTRONICS CORPORATION**

---

**Headquarters:**

No. 12, Innovation 1<sup>st</sup> Road  
Hsinchu Science Park  
Hsinchu, TAIWAN 30076  
Tel: +886 3 563-9977  
Fax: +886 3 563-9966  
[webmaster@emc.com.tw](mailto:webmaster@emc.com.tw)  
<http://www.emc.com.tw>

**Hong Kong:**

**ELAN (HK) Microelectronics Corporation, Ltd.**  
Flat A, 19F., World Tech Centre  
95 How Ming Street, Kwun Tong  
Kowloon, HONG KONG  
Tel: +852 2723-3376  
Fax: +852 2723-7780

**USA:**

**ELAN Information Technology Group (U.S.A.)**  
PO Box 601  
Cupertino, CA 95015  
U.S.A.  
Tel: +1 408 366-8225  
Fax: +1 408 366-8225

**Korea:****ELAN Korea Electronics Company, Ltd.**

301 Dong-A Building  
632 Kojan-Dong, Namdong-ku  
Incheon City, KOREA  
Tel: +82 32 814-7730  
Fax: +82 32 813-7730

**Shenzhen:****ELAN Microelectronics Shenzhen, Ltd.**

8A Floor, Microprofit Building  
Gaoxin South Road 6  
Shenzhen Hi-Tech Industrial Park  
South Area, Shenzhen  
CHINA 518057  
Tel: +86 755 2601-0565  
Fax: +86 755 2601-0500  
[elan-sz@elanic.com.cn](mailto:elan-sz@elanic.com.cn)

**Shanghai:****ELAN Microelectronics Shanghai, Ltd.**

6F, Ke Yuan Building  
No. 5 Bibo Road  
Zhangjiang Hi-Tech Park  
Shanghai, CHINA 201203  
Tel: +86 21 5080-3866  
Fax: +86 21 5080-0273  
[elan-sh@elanic.com.cn](mailto:elan-sh@elanic.com.cn)

---

# Contents

<b>1</b>	<b>General Description</b> .....	<b>1</b>
1.1	Application.....	1
<b>2</b>	<b>Features</b> .....	<b>1</b>
2.1	MCU .....	1
2.2	Peripheral Configuration .....	2
2.3	Internal Specification .....	2
<b>3</b>	<b>Block Diagram</b> .....	<b>3</b>
<b>4</b>	<b>Pin Assignment</b> .....	<b>4</b>
<b>5</b>	<b>Pin Description</b> .....	<b>5</b>
5.1	MCU System Pins (6 Pins).....	5
5.2	Embedded LCD Pins (52 Pins) .....	5
5.3	I/O Port (11 Pins).....	6
<b>6</b>	<b>Code Option</b> .....	<b>7</b>
<b>7</b>	<b>Function Description</b> .....	<b>9</b>
7.1	Reset Function .....	9
7.1.1	Power-on Reset .....	9
7.1.2	RSTB Pin .....	9
7.1.3	WDT Time-out .....	10
7.1.4	Status (R0Fh).....	10
7.1.5	Initialization after Reset.....	12
7.1.5.1	Special Register .....	12
7.1.5.2	Control Register .....	13
7.2	Oscillator System .....	14
7.2.1	60kHz/75kHz/100kHz/200kHz/300kHz RC Oscillator.....	14
7.3	MCU Operation Mode .....	15
7.3.1	Slow, Fast, Sleep, and Idle Mode Operation .....	16
7.3.2	Wake-up Operation .....	18
7.4	Interrupts .....	18
7.4.1	Global Interrupt .....	18
7.4.2	Input Port (Port A.7 ~ Port A.0) Interrupt.....	19
7.4.3	Timer 0, Timer 1, and Timer 2 Interrupts.....	20
7.4.3.1	Timer 0 Interrupt.....	20
7.4.3.2	Timer 1 Interrupt.....	21
7.4.3.3	Timer 2 Interrupt.....	21
7.4.3.4	Code Example:.....	22
7.5	Program ROM Map .....	22



7.6	RAM Map for Special and Control Registers.....	23
7.6.1	Special and Control Registers.....	23
7.6.2	Other Unbanked General RAM.....	25
7.6.3	Banked General RAM.....	25
7.7	LCD RAM Map.....	25
7.8	Special Function Registers.....	26
7.8.1	ACC: Accumulator.....	26
7.8.2	POST_ID: Post Increase/Decrease Control Register.....	26
7.8.3	BSR, FSR0, INDF0: Indirect Address Pointer 0 Registers.....	26
7.8.4	BSR1, FSR1, INDF1: Indirect Address Pointer 1 Registers.....	26
7.8.5	STKPTR: Stack Pointer Register.....	28
7.8.6	PCL, PCM: Program Counter Registers.....	28
7.8.7	TABPTRL, TABPTRM: Table Pointer Registers.....	29
7.8.8	Port A, Port B, Port C, Port D: General I/O Pin Registers.....	30
7.8.9	STBCON: Strobe Output Control Register.....	30
7.8.10	PACON: Port A Control Register.....	31
7.8.11	PAWAKE: Port A Wake-up Control Register.....	31
7.8.12	PAINTEN: Port A Interrupt Enable Control Register.....	32
7.8.13	PAINTSTA: Port A Interrupt Status Register.....	32
7.8.14	DCRA: Port A Direction Control Register.....	32
7.8.15	PBCON: Port B Pull-up Resistor Control Register.....	32
7.8.16	DCRB: Port B Direction Control Register.....	33
7.8.17	PCCON: Port C Pull-up Resistor Control Register.....	33
7.8.18	DCRC: Port C Direction Control Register.....	34
7.8.19	PDCON: Port D Pull up Resistor Control Register.....	34
7.8.20	DCRD: Port D Direction Control Register.....	35
<b>8</b>	<b>Peripheral.....</b>	<b>36</b>
8.1	Timer 0 (16-Bit Timer with Event Counter Function).....	36
8.1.1	Timer 0 Registers.....	37
8.2	Timer 1 (8 Bits).....	40
8.2.1	Timer 1 Registers.....	40
8.3	Timer 2 (8 Bits).....	43
8.3.1	Timer 2 Registers.....	43
8.4	Watchdog Timer (WDT).....	46
8.4.1	Watchdog Timer (WDT) Registers.....	46
8.5	Input/Output Key.....	47
8.5.1	Key Functions.....	49
8.5.2	Key Strobe.....	49
8.5.2.1	Waiting Key in mode.....	49
8.5.2.2	Software Key Scan.....	49
8.5.3	Input/Output Key Registers.....	50



8.6	LCD Driver .....	53
8.6.1	LCD Driver Registers .....	54
8.6.2	LCD RAM Map .....	56
8.6.3	LCD Driving Method Circuit .....	57
8.6.4	LCD COM Waveforms .....	58
8.6.5	LCD COM and SEG Waveforms.....	60
<b>9</b>	<b>Electrical Characteristics .....</b>	<b>63</b>
<b>10</b>	<b>Application Circuits .....</b>	<b>65</b>
<b>11</b>	<b>Instruction Set .....</b>	<b>66</b>
<b>12</b>	<b>Pad Diagram and Pad Locations .....</b>	<b>69</b>
12.1	Pad Coordinates .....	70



### Specification Revision History

Doc. Version	Revision Description	Date
0.1	Initial version	2012/05/02
0.2	Added the description for reset function in Section 7.1.2 Modified the LCD Driving Method Circuit for 1/3 Bias in Section 8.6.3	2012/07/13
0.3	Modified the frequency 150kHz to 75kHz Modified the ERIC circuit	2013/02/05
1.0	<a href="#">Upgraded to version 1.0</a>	<a href="#">2013/06/24</a>

## 1 General Description

The **ePS7100** is an 8-bit RISC MCU embedded with a 5×40 LCD driver along with two 8-bit timers, one 16-bit general timer, and a Watchdog Timer. It also has on-chip 0.5K bytes RAM and 10K words program ROM. It is highly ideal for advance scientific calculator application, particularly those requiring high performance and low cost solution.

The MCU core is one of ELAN's second generation RISC based IC's, known as RISC II (RII) series. The core is specifically designed for low power and portable device applications. The ePS7100 also supports Fast, Slow, and Idle modes, as well as Sleep mode to enhance its low power consumption features.

### IMPORTANT NOTES

- Do not use Register BSR (02h) Bit 7 ~ Bit 2.
- Do not use Register BSR1 (05h) Bit 7 ~ Bit 2.
- Check the range of BSR and BSR1, which should be from 0x00~0x03.
- Do not use LCD RAM 28h ~ FFh.
- Do not use Register JDNZ at FSR1 (04h) special register.
- Do not use PUSH, POP by "MOV A,r" to avoid affecting S\_Z.
- Do not to use TBRD to read the ROM value when TABPRTM:L>0x4FFF

### 1.1 Application

- Calculating machine

## 2 Features

### 2.1 MCU

- 8 bit RISC MCU
- Operating voltage and speed: 1V~2.2V
- Clock Source: Single system clock
- Idle and Slow mode: 8kHz / 16kHz / 32kHz
- Fast mode: 60kHz / 75kHz / 100kHz / 200kHz / 300kHz
- One Instruction cycle time = 2 × System clock time
- Program ROM addressing: Maximum of 10K words
- 128 bytes un-banked RAM including special registers and common registers

- 4×128 bytes banked RAM
- Maximum of 32-level RAM stack
- Table Lookup function is fast and highly efficient when combined with Repeat instruction
- Register-to-Register move instruction
- Compare and Branch in one instruction (two cycles)
- Single Repeat function (256 repeat times max.)
- Decimal ADD and SUB instructions
- Full range Call and Jump ability (two cycles)

## **2.2 Peripheral Configuration**

- 21 general I/O pins (Port A.0~7, Port B.0~7 share with segment pins, Port C.0~1 share with common pins, Port D.0~2)
- 5-/4-/3 COM × 40 SEG LCD driver (embedded), 1/2 bias or 1/3 bias
- One 16-bit timer (Timer 0) with event counter function
- One 8-bit timer (Timer 1) with wake-up function
- One 8-bit timer (Timer 2)
- One 8-bit Watchdog Timer
- Key I/O function with a maximum of 30 keys (Key matrix: Port A.0~5 and Port A.6~7 and Port D.0~2) when LCD driver is 5 x 40

## **2.3 Internal Specification**

- Watchdog Timer with its own on-chip RC oscillator
- MCU operating modes: Sleep Mode, Idle Mode, Slow Mode, and Fast Mode
- Support RC oscillation for system clock
- MCU wake-up function consists of input wake up and Timer 1 wake up
- MCU interrupt function consist of Input port interrupt and Timer interrupt (Timers 0 ~ 2)
- MCU reset function includes power-on reset, RSTB pin reset, and Watchdog timer reset

### 3 Block Diagram

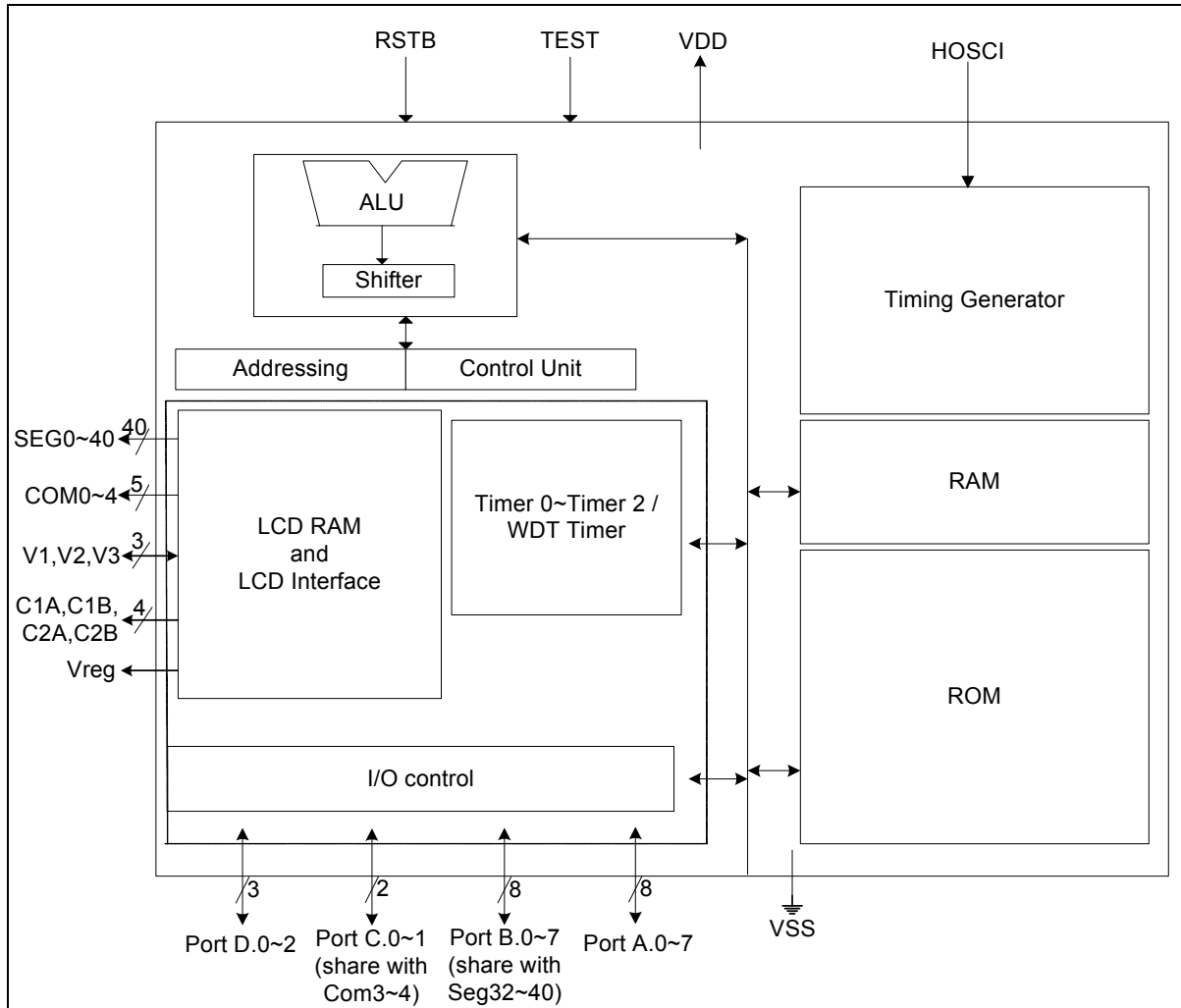

Figure 3-1 ePS7100 Block Diagram

## 4 Pin Assignment

### ■ 69-pin Chip Type

No.	Pin Name	No.	Pin Name	No.	Pin Name	No.	Pin Name
1	VDD	19	SEG6/Strobe6	36	SEG23	53	Test
2	HOSCI	20	SEG7/Strobe7	37	SEG24	54	SEG32/Port B.0
3	RESETB	21	SEG8/Strobe8	38	SEG25	55	SEG33/Port B.1
4	Vreg	22	SEG9/Strobe9	39	SEG26	56	SEG34/Port B.2
5	Port D.2	23	SEG10/Strobe10	40	SEG27	57	SEG35/Port B.3
6	Port D.1	24	SEG11/Strobe11	41	SEG28	58	SEG36/Port B.4
7	Port D.0	25	SEG12/Strobe12	42	SEG29	59	SEG37/Port B.5
8	COM4/Port C.1	26	SEG13/Strobe13	43	SEG30	60	SEG38/Port B.6
9	COM3/Port C.0	27	SEG14/Strobe14	44	SEG31	61	SEG39/Port B.7/EVIN
10	COM2	28	SEG15/Strobe15	45	C1A	62	Port A.7
11	COM1	29	SEG16	46	C1B	63	Port A.6
12	COM0	30	SEG17	47	C2A	64	Port A.5
13	SEG0/Strobe0	31	SEG18	48	C2B	65	Port A.4
14	SEG1/Strobe1	32	SEG19	49	V1	66	Port A.3
15	SEG2/Strobe2	33	SEG20	50	V2	67	Port A.2
16	SEG3/Strobe3	34	SEG21	51	V3	68	Port A.1
17	SEG4/Strobe4	35	SEG22	52	VSS	69	Port A.0
18	SEG5/Strobe5						