ePS6900

**RISC II Series
Microcontroller**

**Product
Specification**

Doc. VERSION 1.0

ELAN MICROELECTRONICS CORP.

November 2010



Trademark Acknowledgments:

IBM is a registered trademark and PS/2 is a trademark of IBM.
Windows is a trademark of Microsoft Corporation.

ELAN and ELAN logo  are trademarks of ELAN Microelectronics Corporation.

Copyright © 2010 by **ELAN Microelectronics Corporation**

All Rights Reserved

Printed in Taiwan

The contents of this specification are subject to change without further notice. ELAN Microelectronics assumes no responsibility concerning the accuracy, adequacy, or completeness of this specification. ELAN Microelectronics makes no commitment to update, or to keep current the information and material contained in this specification. Such information and material may change to conform to each confirmed order.

In no event shall ELAN Microelectronics be made responsible for any claims attributed to errors, omissions, or other inaccuracies in the information or material contained in this specification. ELAN Microelectronics shall not be liable for direct, indirect, special incidental, or consequential damages arising from the use of such information or material.

The software (if any) described in this specification is furnished under a license or nondisclosure agreement, and may be used or copied only in accordance with the terms of such agreement.

ELAN Microelectronics products are not intended for use in life support appliances, devices, or systems. Use of ELAN Microelectronics product in such applications is not supported and is prohibited.

NO PART OF THIS SPECIFICATION MAY BE REPRODUCED OR TRANSMITTED IN ANY FORM OR BY ANY MEANS WITHOUT THE EXPRESSED WRITTEN PERMISSION OF ELAN MICROELECTRONICS.



ELAN MICROELECTRONICS CORPORATION

Headquarters:

No. 12, Innovation 1st Road
Hsinchu Science Park
Hsinchu, TAIWAN 30076
Tel: +886 3 563-9977
Fax: +886 3 563-9966
webmaster@emc.com.tw
<http://www.emc.com.tw>

Hong Kong:

Elan (HK) Microelectronics Corporation, Ltd.
Flat A, 19F., World Tech Centre
95
How Ming Street, Kwun Tong
Kowloon, HONG KONG
Tel: +852 2723-3376
Fax: +852 2723-7780

USA:

Elan Information Technology Group (U.S.A.)
PO Box 601
Cupertino, CA 95015
U.S.A.
Tel: +1 408 366-8225
Fax: +1 408 366-8225

Korea:**Elan Korea Electronics Company, Ltd.**

301 Dong-A Building
632 Kojan-Dong, Namdong-ku
Incheon City, KOREA
Tel: +82 32 814-7730
Fax: +82 32 813-7730

Shenzhen:**Elan Microelectronics Shenzhen, Ltd.**

3F, SSMEC Bldg., Gaoxin S. Ave. 1
Shenzhen Hi-tech Industrial Park
(South Area), Shenzhen
CHINA 518057
Tel: +86 755 2601-0565
Fax: +86 755 2601-0500
elan-sz@elanic.com.cn

Shanghai:**Elan Microelectronics Shanghai, Ltd.**

3F, Building #13
No. 116, Lane 572, Bibo Road
Zhangjiang Hi-Tech Park
Shanghai, CHINA 201203
Tel: +86 21 5080-3866
Fax: +86 21 5080-4600
elan-sh@elanic.com.cn

Contents

1	General Description	1
1.1	Application.....	1
2	Features	1
3	Block Diagram	3
4	Pin Assignment.....	4
5	Pin Description	6
5.1	MCU System Pins (8 Pins).....	6
5.2	Embedded LCD Pins (137 Pins)	6
5.3	I/O Port (20 Pins).....	6
6	Code Option	7
7	Function Description.....	8
7.1	Reset Function	8
7.1.1	Power-on Reset.....	8
7.1.2	RSTB Pin.....	8
7.1.3	WDT Time Out.....	8
7.1.4	32768 Crystal Stable Time	9
7.1.5	Status (ROFh)	10
7.1.6	Initialization after Reset	11
7.1.6.1	Special Register	12
7.1.6.2	Control Register	12
7.2	Oscillator System	13
7.2.1	32.8kHz RC or 32768Hz Crystal Oscillator	13
7.2.2	200kHz/300kHz/500kHz/1 MHz RC Oscillator.....	14
7.3	MCU Operation Mode	15
7.3.1	Slow, Fast, Sleep, and Idle Modes Operation.....	16
7.3.2	Wake-up Operation	18
7.4	Interrupts	18
7.4.1	Global Interrupt.....	18
7.4.2	Input Port (PortA.7 ~ PortA.0) Interrupt.....	19
7.4.3	Timer 0, Timer 1, and Timer 2 Interrupts	20
7.4.3.1	Timer 0 Interrupt.....	20
7.4.3.2	Timer 1 Interrupt.....	21
7.4.3.3	Timer 2 Interrupt.....	21
7.4.3.4	Code Example.....	22
7.5	Program ROM Map	23
7.6	RAM Map for Special Function and Control Registers	24
7.6.1	Special Function and Control Registers.....	24
7.6.2	Other Un-banked General RAM.....	27
7.6.3	Banked General RAM	27



7.6	RAM Map for Special Function and Control Registers	24
7.6.1	Special Function and Control Registers	24
7.6.2	Other Un-banked General RAM	27
7.6.3	Banked General RAM	27
7.7	LCD RAM Map	28
7.8	Special Function Registers	28
7.8.1	ACC: Accumulator Register	28
7.8.2	POST_ID: Post Increase / Decrease Control Register	28
7.8.3	BSR, FSR0, INDF0: Indirect Address Pointer 0 Registers	28
7.8.4	BSR1, FSR1, INDF1: Indirect Address Pointer 1 Registers	29
7.8.5	BSR2, FSR2, INDF2: Indirect Address Pointer 2 Registers	29
7.8.6	STKPTR: Stack Pointer Register	32
7.8.7	PCL, PCM, PCH: Program Counter Registers	32
7.8.8	TABPTRL, TABPTRM, TABPTH: Table Pointer Registers	33
7.8.9	CPUCON: MCU Control Register	34
7.8.10	STBCON: Strobe Output Control Register	34
7.8.11	Port A: General I/O Pins Register	35
7.8.12	PACON: Port A Control Register	35
7.8.13	DCRA: Port A Direction Control Register	35
7.8.14	PAWAKE: Port A Wake-up Control Register	35
7.8.15	PAINTEN: Port A Interrupt Enable Control Register	35
7.8.16	PAINTSTA: Port A Interrupt Status Register	36
7.8.17	Port B: General I/O Pin Registers	36
7.8.18	PBCON: Port B Pull-up Resistor Control Register	36
7.8.19	DCRB (R39h): Port B Direction Control Register	36
7.8.20	Port C (R3Ah): General I/O Pin Register	36
7.8.21	PCCON (R3Bh): Port C Pull-up Resistor Control Register	37
7.8.22	DCRC: Port C Direction Control Register	37
7.8.23	Port D, Port E: General I/O Pins Registers	37
7.8.24	DCRDE: Port D/Port E Direction Control and Pull-up Register	37
8	Peripheral	38
8.1	Timer 0 (16 Bits Timer with Event Counter Function)	38
8.1.1	Timer 0 Registers	40
8.2	Timer 1 (8 Bits)	42
8.2.1	Timer 1 Registers	42
8.3	Timer 2 (8 Bits)	45
8.3.1	Timer 2 Registers	45
8.4	Watchdog Timer (WDT)	48
8.4.1	Watchdog Timer (WDT) Registers	48

8.5	Input/Output Key	49
8.5.1	Key Functions.....	50
8.5.2	Key Strobe (PA.7 ~ 0 and PB.7 ~ 0 and PC.3 ~ 0)	50
8.5.3	Input/Output Key Registers	51
8.6	LCD Driver.....	55
8.6.1	LCD Driver Registers	56
8.6.2	LCD RAM Map	59
8.6.3	LCD Driving Method Circuit.....	59
8.6.4	LCD COM Waveforms.....	60
8.6.4.1	1/32 Duty and 1/4 Bias	60
8.6.4.2	1/32 Duty and 1/5 Bias	61
8.6.5	LCD COM and SEG Waveforms	61
8.6.5.1	1/32 Duty and 1/4 Bias	62
8.6.5.2	1/32 Duty and 1/5 Bias	63
9	Electrical Characteristics.....	64
9.1	VDD = 1.5V Electrical Characteristics	64
9.2	VDD = 3.0V Electrical Characteristics	66
10	Pin Type Circuit Diagrams	68
11	Application Circuits.....	70
12	Instruction Set	71
13	Pad Diagram and Locations	74



Specification Revision History

Doc. Version	Revision Description	Date
1.0	Initial version	2010/11/22

1 General Description

The **ePS6900** is an 8-bit RISC MCU embedded with a 32×98 LCD driver along with two 8-bit timers, one 16-bit general timer, and a Watchdog Timer. Furthermore, ePS6900 is equipped with 8K bytes RAM and 96K words program ROM. It is highly ideal for advance scientific calculator application, particularly those that need a high performance at low cost solution.

The MCU core is a one of ELAN's second generation RISC based IC's, known as RISC II (RII) series. The core was specifically designed for low power and portable device applications. The ePS6900 also supports Fast, Slow and Idle modes, as well as Sleep mode to enhance its low power consumption features.

IMPORTANT NOTES

- Do not use Register BSR (02h) Bit7 ~ Bit6
- Do not use Register BSR1 (05h) Bit7 ~ Bit6.
- Do not use Register BSR2 (12h) Bit7 ~ Bit6.
- Do not use LCD RAM 62h ~ FFh.
- Do not use Registers JDNZ at FSR1 (04h) & FSR2 (11h) special register.
- Don't to use PUSH, POP by "MOV A,r" to avoid effecting S_Z

1.1 Application

- Scientific calculating gadgets

2 Features

MCU

- 8 bit RISC MCU
- Operating voltage: 1.2V ~ 3.6V
- Clock Source: Dual clock system
 - Low-frequency: 32kHz Internal RC oscillator / External RC oscillator / Crystal oscillator
 - High-frequency: 200kHz / 300kHz / 500kHz / 1 MHz Internal RC oscillator / External RC oscillator
- One Instruction cycle time = 2 × System clock time
- Program ROM addressing: 96K words max.



- Provides Special registers and Control registers
- 104 bytes un-banked RAM and Working RAM
- 64 ×128 bytes banked RAM
- RAM stack can achieve a maximum of 32 stack levels
- 3 sets RAM indirect addressing pointer
- Look-up Table function is fast and highly efficient when combined with Repeat instruction
- Register-to-Register move instruction
- Compare and Branch in one instruction (2 cycles)
- Single Repeat function (max. of 256 repeat times)
- Decimal ADD and SUB instruction
- Full range CALL and JUMP ability (2 cycles)

Peripheral

- 36 General I/O pins (Port A, Port B, Port C.0~3, Port D, Port E)
- 32 COM × 98 SEG LCD driver (embedded), 1/16, 1/20, 1/24, 1/28 and 1/32 duty, 1/4 and 1/5 bias.
- One (Timer 0) 16-bit timer with Event counter function
- One (Timer 1) 8-bit timer with wake-up function
- One (Timer 2) 8-bit timer
- One 8-bit Watchdog Timer
- Key I/O function with 96 keys max.

Internal Specification

- Watchdog Timer with its own on-chip RC oscillator
- MCU operating modes: Sleep Mode, Idle Mode, Slow Mode, and Fast Mode
- Supports RC oscillation and crystal oscillation for clock system
- MCU Wake-up function consists of Input Wake-up and Timer 1 Wake-up
- MCU interrupt function consists of Input Port Interrupt and Timer Interrupt (Timers 0 ~ 2)
- MCU reset function includes power-on reset, RSTB pin reset, and Watchdog timer reset.

3 Block Diagram

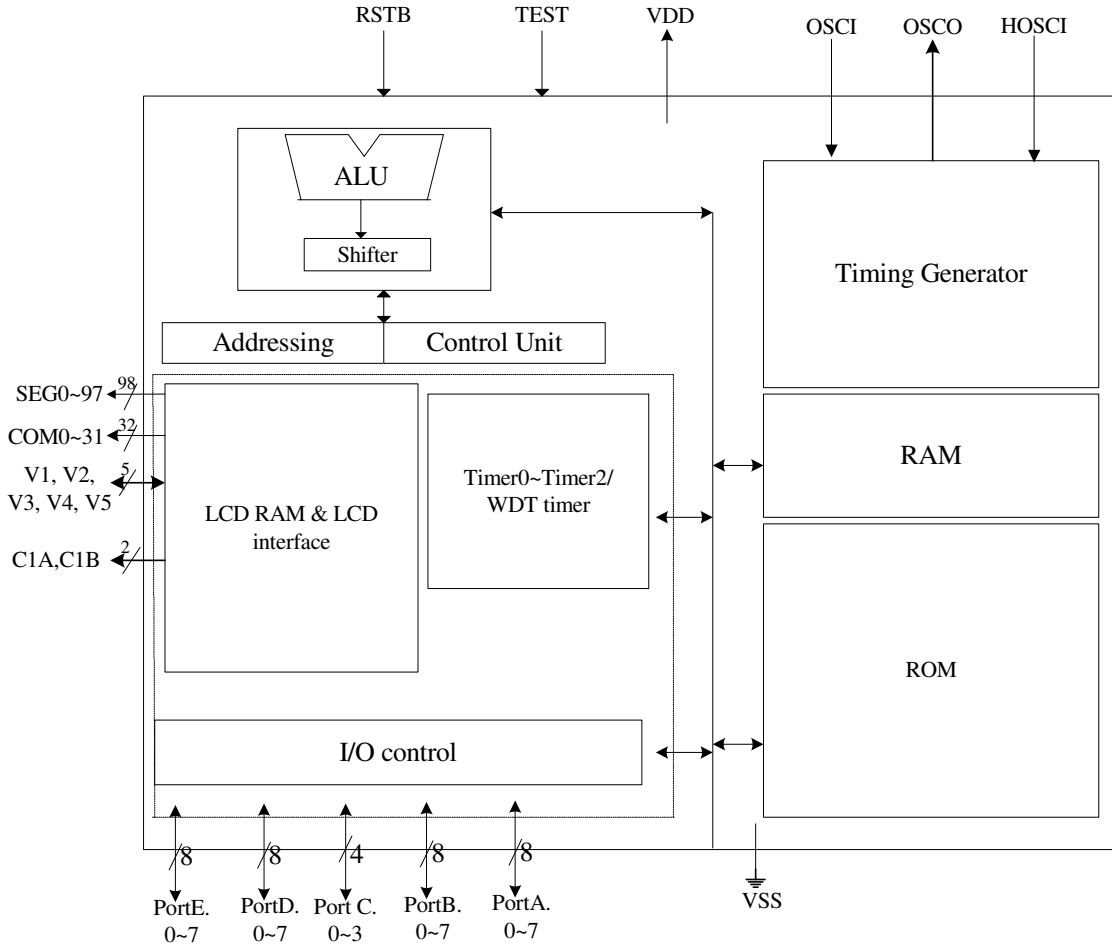

Figure 3-1 ePS6900 Block Diagram

4 Pin Assignment

■ 165-pin Chip Format

No.	Pin Name	No.	Pin Name	No.	Pin Name	No.	Pin Name
1	NC	31	SEG3/Strobe3	61	SEG23	91	SEG53
2	NC	32	SEG4/Strobe4	62	SEG24	92	SEG54
3	NC	33	SEG5/Strobe5	63	SEG25	93	SEG55
4	VSS	34	SEG6/Strobe6	64	SEG26	94	SEG56
5	C1A	35	SEG7/Strobe7	65	SEG27	95	SEG57
6	C1B	36	SEG8/Strobe8	66	SEG28	96	SEG58
7	V5	37	SEG9/Strobe9	67	SEG29	97	NC
8	V4	38	SEG10/Strobe10	68	SEG30	98	NC
9	V3	39	SEG11/Strobe11	69	SEG31	99	NC
10	V2	40	SEG12/Strobe12	70	SEG32	100	NC
11	V1	41	SEG13/Strobe13	71	SEG33	101	NC
12	COM15	42	SEG14/Strobe14	72	SEG34	102	NC
13	COM14	43	SEG15/Strobe15	73	SEG35	103	NC
14	COM13	44	SEG16	74	SEG36	104	NC
15	COM12	45	SEG17	75	SEG37	105	NC
16	COM11	46	SEG18	76	SEG38	106	NC
17	COM10	47	SEG19	77	SEG39	107	SEG59
18	COM9	48	SEG20	78	SEG40	108	SEG60
19	COM8	49	SEG21	79	SEG41	109	SEG61
20	COM7	50	SEG22	80	SEG42	110	SEG62
21	COM6	51	NC	81	SEG43	111	SEG63
22	COM5	52	NC	82	SEG44	112	SEG64
23	COM4	53	NC	83	SEG45	113	SEG65
24	COM3	54	NC	84	SEG46	114	SEG66
25	COM2	55	NC	85	SEG47	115	SEG67
26	COM1	56	NC	86	SEG48	116	SEG68
27	COM0	57	NC	87	SEG49	117	SEG69
28	SEG0/Strobe0	58	NC	88	SEG50	118	SEG70
29	SEG1/Strobe1	59	NC	89	SEG51	119	SEG71
30	SEG2/Strobe2	60	NC	90	SEG52	120	SEG72



No.	Pin Name	No.	Pin Name	No.	Pin Name	No.	Pin Name
121	SEG73	143	SEG95	165	NC	187	PortB.4
122	SEG74	144	SEG96	166	COM24/PortE.0	188	PortB.5
123	SEG75	145	SEG97	167	COM25/PortE.1	189	PortB.6
124	SEG76	146	COM16/PortD.0	168	COM26/PortE.2	190	PortB.7
125	SEG77	147	COM17/PortD.1	169	COM27/PortE.3	191	PortC.0
126	SEG78	148	COM18/PortD.2	170	COM28/PortE.4	192	PortC.1
127	SEG79	149	COM19/PortD.3	171	COM29/PortE.5	193	PortC.2
128	SEG80	150	COM20/PortD.4	172	COM30/PortE.6	194	PortC.3/EVIN
129	SEG81	151	COM21/PortD.5	173	COM31/PortE.7	195	VDD
130	SEG82	152	COM22/PortD.6	174	PortA.0	196	HOSCI
131	SEG83	153	COM23/PortD.7	175	PortA.1	197	RESETB
132	SEG84	154	NC	176	PortA.2	198	OSCO
133	SEG85	155	NC	177	PortA.3	199	OSCI
134	SEG86	156	NC	178	TEST	200	NC
135	SEG87	157	NC	179	PortA.4	201	NC
136	SEG88	158	NC	180	PortA.5	202	NC
137	SEG89	159	NC	181	PortA.6	203	NC
138	SEG90	160	NC	182	PortA.7	204	NC
139	SEG91	161	NC	183	PortB.0	205	NC
140	SEG92	162	NC	184	PortB.1	206	NC
141	SEG93	163	NC	185	PortB.2	207	NC
142	SEG94	164	NC	186	PortB.3	208	NC

5 Pin Description

5.1 MCU System Pins (8 Pins)

Name	I/O/P Type	Description	Note
VDD	P	Digital and Analog positive power supply, ranging from 1.2V ~ 1.8V / 2.4V ~ 3.6V. Connect to VSS through the 0.1 μ F capacitor.	–
VSS	P	Digital and Analog negative power supply.	–
RSTB	I	System reset pin (Low active).	Int. pull-up
TEST	I	Test mode select pin (High active). For IC internal test only, normally connect to VSS.	Int. Pull Down
VSS	P	Digital and Analog negative power supply	–
OSCI	I	External RC/Crystal oscillator connecting pin	Ext. R to VDD
OSCO	O	Crystal oscillator connecting pin	–
HOSCI	I	Hi-Speed RC oscillator connecting pin	Ext. R to VDD

5.2 Embedded LCD Pins (137 Pins)

Name	I/O/P Type	Description	Note
COM0~COM15	O	LCD common signal output pin	–
COM16~COM23 / PortD.0~7	O I/O	LCD common signal output pin General Input/Output port	–
COM24~COM31 / Port E.0~7	O I/O	LCD common signal output pin General Input/Output port	–
SEG0~SEG15	O	LCD segment signal output pin shared with key Strobe 0~15	–
SEG16~ SEG97	O	LCD segment signal output pin	–
C1A, C1B	–	LCD voltage charge-pump pin. Connect 1 μ F between C1A and C1B.	–
V5, V4, V3, V2, V1	O	LCD bias Pin. Connect 1 μ F to Vss.	–

5.3 I/O Port (20 Pins)

Name	I/O/P Type	Description	Note
PortA.0~7	I	General Input port for special functions, i.e., Wake-up and Interrupt	–
	O	General Output port	
	I	Bits 6~0: Key matrix input pins	
PortB.0~7	I/O	General Input/Output port	–
PortC.0~3	I/O	General Input/Output port	–
	I	Bit 3: Event counter input pin	

6 Code Option

Located at Address 0x000C~0x000F of Program ROM

- Initial mode after reset:
 - Select “Slow” mode or “Fast” mode

NOTE

For Initial mode after reset, it is recommended that user set it to “Slow mode”.

- Low Frequency Oscillator:
 - Select “Crystal” oscillator or “Internal RC” oscillator or “External RC” oscillator
- High Frequency Oscillator:
 - Select “Internal RC” oscillator or “External RC” oscillator
- The Frequency of Internal High RC Oscillator:
 - Select “200kHz” or “300kHz” or “500kHz” or “1 MHz”
- Operating voltage option:
 - Select “1.5V” or “3V”
- RESET pin’s condition:
 - Select “Level hold” or “One shot” for reset pin
- Maximum duty ratio option:
 - Select “1/32 duty” or “1/28 duty” or “1/24 duty” or “1/20 duty” or “1/16 duty”
- LCD bias and LCD regulator voltage option:
 - Select “1/5 bias and 1.1V” or “1/5 bias and 1.2V” or “1/4 bias and 1.2V” or “1/4 bias and 1.3V” or “1/4 bias and 1.4V”
- Port D low nibble control bit (COM16~COM19):
 - Select “LCD common signal output” or “general I/O functions”
- Port D high nibble control bit (COM20~COM23):
 - Select “LCD common signal output” or “general I/O functions”
- Port E low nibble control bit (COM24~COM27):
 - Select “LCD common signal output” or “general I/O functions”
- Port E high nibble control bit (COM28~COM31):
 - Select “LCD common signal output” or “general I/O functions”

7 Function Description

7.1 Reset Function

RESET can be generated by one of the following:

- Power-on voltage detector reset and power-on reset.
- WDT time out
- RSTB pin pull low

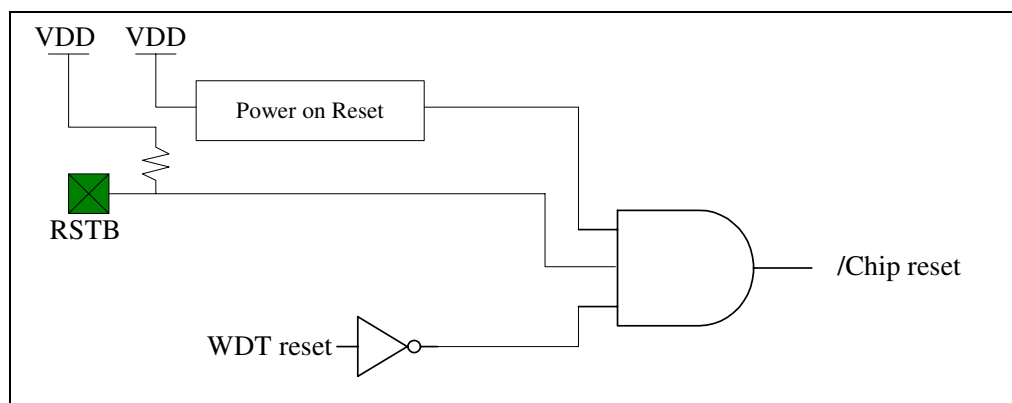

Figure 7-1 On-chip Reset Schematic Diagram

7.1.1 Power-on Reset

The power-on reset circuit holds the device under reset condition until VDD is above V_{por} (power-on reset voltage). Whenever the voltage supply lowers to below V_{por}, a reset will occur.

7.1.2 RSTB Pin

In normal condition, the RSTB pin is pulled-up to VDD. Whenever the RSTB pin is at low condition (level hold or one short), a reset will occur.

7.1.3 WDT Time Out

When Watchdog Timer is enabled, the WDT time-out will cause the chip to reset. To prevent reset from occurring, you should clear the WDT value with the "WDTC" instruction before WDT time-out. WDT time-out can also be used to flag software malfunction.