ePS6001

**RISC II Series
Microcontroller**

Product Specification

DOC. VERSION 1.0

ELAN MICROELECTRONICS CORP.

December 2012



Trademark Acknowledgments:

IBM is a registered trademark and PS/2 is a trademark of IBM.

Windows is a trademark of Microsoft Corporation.

ELAN and ELAN logo  are trademarks of ELAN Microelectronics Corporation.

Copyright © 2012 by **ELAN Microelectronics Corporation**

All Rights Reserved

Printed in Taiwan

The contents of this specification are subject to change without further notice. ELAN Microelectronics assumes no responsibility concerning the accuracy, adequacy, or completeness of this specification. ELAN Microelectronics makes no commitment to update, or to keep current the information and material contained in this specification. Such information and material may change to conform to each confirmed order.

In no event shall ELAN Microelectronics be made responsible for any claims attributed to errors, omissions, or other inaccuracies in the information or material contained in this specification. ELAN Microelectronics shall not be liable for direct, indirect, special incidental, or consequential damages arising from the use of such information or material.

The software (if any) described in this specification is furnished under a license or nondisclosure agreement, and may be used or copied only in accordance with the terms of such agreement.

ELAN Microelectronics products are not intended for use in life support appliances, devices, or systems. Use of ELAN Microelectronics product in such applications is not supported and is prohibited.

NO PART OF THIS SPECIFICATION MAY BE REPRODUCED OR TRANSMITTED IN ANY FORM OR BY ANY MEANS WITHOUT THE EXPRESSED WRITTEN PERMISSION OF ELAN MICROELECTRONICS.



ELAN MICROELECTRONICS CORPORATION

Headquarters:

No. 12, Innovation 1st Road
Hsinchu Science Park
Hsinchu, TAIWAN 30076
Tel: +886 3 563-9977
Fax: +886 3 563-9966
webmaster@emc.com.tw
<http://www.emc.com.tw>

Hong Kong:

ELAN (HK) Microelectronics Corporation, Ltd.
Flat A, 19F., World Tech Centre
95 How Ming Street, Kwun Tong
Kowloon, HONG KONG
Tel: +852 2723-3376
Fax: +852 2723-7780

USA:

ELAN Information Technology Group (U.S.A.)
PO Box 601
Cupertino, CA 95015
U.S.A.
Tel: +1 408 366-8225
Fax: +1 408 366-8225

Korea:**ELAN Korea Electronics Company, Ltd.**

301 Dong-A Building
632 Kojan-Dong, Namdong-ku
Incheon City, KOREA
Tel: +82 32 814-7730
Fax: +82 32 813-7730

Shenzhen:**ELAN Microelectronics Shenzhen, Ltd.**

8A Floor, Microprofit Building
Gaoxin South Road 6
Shenzhen Hi-Tech Industrial Park
South Area, Shenzhen
CHINA 518057
Tel: +86 755 2601-0565
Fax: +86 755 2601-0500
elan-sz@elanic.com.cn

Shanghai:**ELAN Microelectronics Shanghai, Ltd.**

6F, Ke Yuan Building
No. 5 Bibo Road
Zhangjiang Hi-Tech Park
Shanghai, CHINA 201203
Tel: +86 21 5080-3866
Fax: +86 21 5080-0273
elan-sh@elanic.com.cn

Contents

1	General Description	1
1.1	Application.....	1
2	Features	1
2.1	MCU	1
2.2	Peripheral Configuration.....	2
2.3	Internal Specification	2
3	Block Diagram	3
4	Pin Assignment.....	4
5	Pin Description	5
5.1	MCU System Pins (5 Pins).....	5
5.2	Embedded LCD Pins (77 Pins)	5
5.3	I/O Port (6 Pins).....	5
6	Code Option	6
7	Function Description.....	8
7.1	Reset Function	8
7.1.1	Power-on Reset.....	8
7.1.2	RSTB Pin.....	8
7.1.3	WDT Time-out	9
7.1.4	Status (R0Fh)	9
7.1.5	Initialization after Reset.....	11
7.1.5.1	Special Register	11
7.1.5.2	Control Register	11
7.2	Oscillator System	12
7.2.1	32.8 kHz Internal RC Oscillator.....	12
7.2.2	200kHz/300kHz/500kHz/1MHz/1.5MHz/2MHz RC External Oscillator.....	12
7.3	MCU Operation Mode	13
7.3.1	Slow, Fast, Sleep, and Idle Mode Operations.....	14
7.3.2	Wake-up Operation	16
7.4	Interrupts	16
7.4.1	Global Interrupt.....	16
7.4.2	Input Port (Port A.5 ~ Port A.0) Interrupt	17
7.4.3	Timer 0, Timer 1, and Timer 2 Interrupts	18
7.4.3.1	Timer 0 Interrupt.....	18
7.4.3.2	Timer 1 Interrupt.....	19
7.4.3.3	Timer 2 Interrupt.....	19
7.4.3.4	Code Example:.....	20
7.5	Program ROM Map	20

7.6	RAM Map for Special and Control Registers	21
7.6.1	Special and Control Registers	21
7.6.2	Other Unbanked General RAM	23
7.6.3	Banked General RAM	23
7.7	LCD RAM Map	23
7.8	Special Function Registers	24
7.8.1	ACC (R0Ah): Accumulator	24
7.8.2	POST_ID (R33h): Post Increase / Decrease Control Register	24
7.8.3	BSR, FSR0, INDF0 (R02h, R01h, R00h): Indirect Address Pointer 0 Registers	24
7.8.4	BSR1, FSR1, INDF1 (R05h, R04h, R03h): Indirect Address Pointer 1 Registers	24
7.8.5	STKPTR (R06h): Stack Pointer Register	26
7.8.6	PCL, PCM (R07h, R08h): Program Counter Registers	26
7.8.7	TABPTRL, TABPTRM (R0Bh, R0Ch): Table Pointer Registers	27
7.8.8	Port A, Port B, Port C (R10h, R11h, R12h): General I/O Pin Registers	28
7.8.9	STBCON (R20): Strobe Output Control Register	28
7.8.10	PACON (R29h): Port A Control Register	28
7.8.11	PAWAKE (R2Ah): Port A Wake-up Control Register	29
7.8.12	PAINTEN (R2Bh): Port A Interrupt Enable Control Register	29
7.8.13	PAINTSTA (R2Ch): Port A Interrupt Status Register	29
7.8.14	DCRA (R2Dh): Port A Direction Control Register	29
7.8.15	PBCON (R2Eh): Port B Pull up Resistor Control Register	30
7.8.16	DCRB (R2Fh): Port B Direction Control Register	30
7.8.17	PCCON (R30h): Port C Pull up Resistor Control Register	31
7.8.18	DCRC (R31h): Port C Direction Control Register	31
8	Peripheral	32
8.1	Timer 0 (16 Bits Timer with Event Counter Function)	32
8.1.1	Timer 0 Registers	32
8.2	Timer 1 (8 Bits)	35
8.2.1	Timer 1 Registers	35
8.3	Timer 2 (8 Bits)	37
8.3.1	Timer 2 Registers	38
8.4	Watchdog Timer (WDT)	40
8.4.1	Watchdog Timer (WDT) Registers	40
8.5	Input/Output Key	41
8.5.1	Key Functions	42
8.5.2	Key Strobe	43
8.5.2.1	Automatic Key Scan	43
8.5.2.2	Software Key Scan	44
8.5.2.3	Key Strobe Pin Function	45
8.5.3	Input/Output Key Registers	45

8.6	LCD Driver.....	49
8.6.1	LCD Driver Registers	50
8.6.2	LCD RAM Map	52
8.6.3	LCD Driving Method Circuit.....	52
8.6.4	LCD COM Waveforms.....	53
8.6.5	LCD COM and SEG Waveforms	55
9	Electrical Characteristics.....	56
9.1	VDD=1.5V Electrical Characteristics	56
9.2	VDD=3.0V Electrical Characteristics	58
10	Pin Type Circuit Diagrams	60
11	Application Circuits.....	62
12	Instruction Set	63
13	Pad Diagram and Locations	66
13.1	Pad Coordinates.....	67



Specification Revision History

Doc. Version	Revision Description	Date
1.0	Initial Release of Official Version	2012/12/14

1 General Description

The **ePS6001** is an 8-bit RISC MCU embedded with a 9×60 LCD driver along with two 8-bit timers, one 16-bit general timer, and a watchdog timer. It has also on-chip 2K bytes RAM and 24K words program ROM. It is highly ideal for advance scientific calculator application, particularly those requiring high performance and low cost solution.

The MCU core is one of ELAN's second generation RISC based IC's, known as RISC II (RII) series. The core was specifically designed for low power and portable device applications. The ePS6001 also supports Fast mode, Slow mode, Idle mode, as well as Sleep mode to enhance its low power consumption features.

IMPORTANT NOTES

- Do not use Register BSR (02h) Bit 7 ~ Bit 4.
- Do not use Register BSR1 (05h) Bit 7 ~ Bit 4.
- Do not use LCD RAM 3Ch ~ 3Fh and 7Ch ~ FFh.
- Do not use Register JDNZ at FSR1 (04h) special register.
- Do not to use TBRD to read Rom value when TABPRTM: L>0xBFFF
- Do not use PUSH, POP by "MOV A,r" to avoid affecting S_Z.
- Do not to use the I/O pins: PortA.6~7 and COM9~10

1.1 Application

- Scientific calculating machine

2 Features

2.1 MCU

- 8 bit RISC MCU
- Operating voltage: 1.2V~3.6V
- Clock Source: Dual system clock:
 - Low-frequency: 32kHz Internal RC oscillator
 - High-frequency: 200kHz / 300kHz / 500kHz / 1MHz / 1.5MHz / 2MHz External RC oscillator (≥ 1 MHz only for VDD=2.4~3.6V)
- One Instruction cycle time = 2 × System clock time
- Program ROM addressing: Max. of 24K words

- 128 bytes un-banked RAM including special registers and common registers
- 16×128 bytes banked RAM
- Max. of 32 levels RAM stack
- Table Look-up function is fast and highly efficient when combined with Repeat instruction
- Register-to-Register move instruction
- Compare and Branch in one instruction (2 cycles)
- Single Repeat function (256 repeat times max.)
- Decimal ADD and SUB instruction
- Full range Call and Jump ability (2 cycles)

2.2 Peripheral Configuration

- 22 general I/O pins (Port A.0~5, Port B.0~7, Port C.0~7)
- 9 / 5 COM × 60 SEG LCD driver (embedded)
- One 16-bit timer (Timer 0) with event counter function
- One 8-bit timer (Timer 1) with Wake-up function
- One 8-bit timer (Timer 2)
- One 8-bit Watchdog Timer
- Key I/O function with 64 keys maximum

2.3 Internal Specification

- Watchdog Timer with its own on-chip RC oscillator
- MCU operating modes: Sleep Mode, Idle Mode, Slow Mode, and Fast Mode
- Supports RC oscillation for system clock
- MCU Wake-up function consists of input Wake-up and Timer 1 Wake up
- MCU interrupt function consist of Input Port Interrupt and Timer Interrupt (Timers 0 ~ 2)

3 Block Diagram

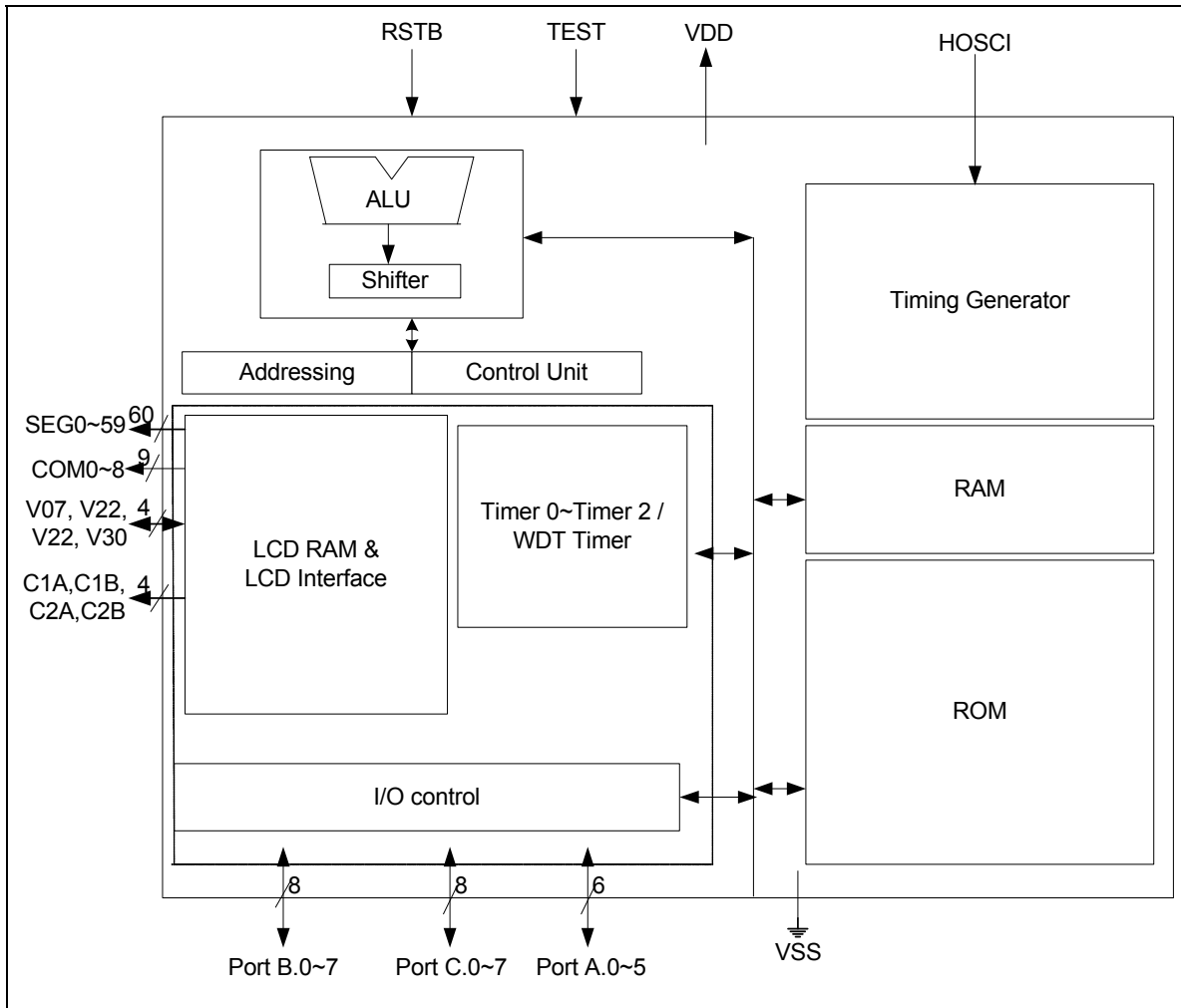

Figure 3-1 ePS6001 Block Diagram

4 Pin Assignment

■ 88-pin Chip Type

No.	Pin Name	No.	Pin Name	No.	Pin Name	No.	Pin Name
1	PortA.0	23	SEG3/Strobe3	45	SEG25	67	C2B
2	PortA.1	24	SEG4/Strobe4	46	SEG26	68	V07
3	PortA.2	25	SEG5/Strobe5	47	SEG27	69	V15
4	PortA.3	26	SEG6/Strobe6	48	SEG28	70	V22
5	PortA.4	27	SEG7/Strobe7	49	SEG29	71	V30
6	PortA.5	28	SEG8/Strobe8	50	SEG30	72	VSS
7	VDD	29	SEG9/Strobe9	51	SEG31	73	SEG44/PortC.0
8	HOSCI	30	SEG10/Strobe10	52	SEG32	74	SEG45/PortC.1
9	RESETB	31	SEG11/Strobe11	53	SEG33	75	SEG46/PortC.2
10	TEST	32	SEG12/Strobe12	54	SEG34	76	SEG47/PortC.3
11	COM8	33	SEG13/Strobe13	55	SEG35	77	SEG48/PortC.4
12	COM7	34	SEG14/Strobe14	56	SEG36	78	SEG49/PortC.5
13	COM6	35	SEG15/Strobe15	57	SEG37	79	SEG50/PortC.6
14	COM5	36	SEG16	58	SEG38	80	SEG51/PortC.7
15	COM4	37	SEG17	59	SEG39	81	SEG52/PortB.0
16	COM3	38	SEG18	60	SEG40	82	SEG53/PortB.1
17	COM2	39	SEG19	61	SEG41	83	SEG54/PortB.2
18	COM1	40	SEG20	62	SEG42	84	SEG55/PortB.3
19	COM0	41	SEG21	63	SEG43	85	SEG56/PortB.4
20	SEG0/Strobe0	42	SEG22	64	C1A	86	SEG57/PortB.5
21	SEG1/Strobe1	43	SEG23	65	C1B	87	SEG58/PortB.6
22	SEG2/Strobe2	44	SEG24	66	C2A	88	SEG59/PortB.7

5 Pin Description

5.1 MCU System Pins (5 Pins)

Name	I/O/P Type	Description	Note
VDD	P	Digital and Analog positive power supply The range is 1.2V~3.6V.	–
VSS	P	Digital and Analog negative power supply	–
RSTB	I	System reset pin (Low active). Connect 0.1 μ F to VSS.	Int. Pull-up
TEST	I	Test mode select pin (High active). For chip internal test use only. Connects to VSS normally.	Int. Pull Down
HOSCI	I	Hi-Speed RC oscillator connecting pin	Ext. R to VDD

5.2 Embedded LCD Pins (77 Pins)

Name	I/O/P Type	Description	Note
COM0~COM8	O	LCD common signal output pin	–
SEG0~SEG15	O	LCD segment signal output pin shared with Key Strobe 0~15	–
SEG16~ SEG31	O	LCD segment signal output pin	–
SEG44~SEG51/ PortC.0~7	I/O	LCD segment signal output pin or I/O pin; define by code option	–
SEG52~SEG59/ PortB.0~7	I/O	LCD segment signal output pin or I/O pin; define by code option	–
C1A, C1B	–	LCD voltage charge-pump pin. Connect 0.1 μ F between C1A and C1B.	–
C2A, C2B	–	LCD voltage charge-pump pin. Connect 0.1 μ F between C2A and C2B.	–
V30, V22, V15, V07	O	LCD bias Pin. Connect 0.1 μ F to Vss	–

5.3 I/O Port (6 Pins)

Port	Bit	Function	I/O Type	Power Source	Description	Note
Port A	Bits 3~0 (for key scan)	General Input	I	VDD	Key input	Int. Pull-up (R1: Small resistor, R2: Large resistor) controllable
		Interrupt and Wake-up	I	VDD	Input port interrupt and Wake-up pin	
		General Output	O	VDD	–	
	Bits 5~4	General Input	I	VDD	–	Int. Pull-up (R2: Large resistor) controllable
		Interrupt and Wake-up	I	VDD	Input port interrupt and Wake-up pin	
		General Output	O	VDD	–	

6 Code Option

Located at Address 0x000C~0x000F of Program ROM

- Initial mode after reset:
 - Select “Slow” mode or “Fast” mode

NOTE

For Initial mode after reset, it is recommended that you set the setting to “Slow mode.”

- Reset pin condition:
 - Select “Level hold” or “One short” for reset pin
- Operating voltage option:
 - Select “1.5V” or “3V”
- Maximum duty ratio option:
 - Select “1/9 duty” or “1/5 duty”
- Port B.0 control bit (SEG52):
 - Select “LCD segment signal output” or “general I/O function”
- Port B.1 control bit (SEG53):
 - Select “LCD segment signal output” or “general I/O function”
- Port B.2 control bit (SEG54):
 - Select “LCD segment signal output” or “general I/O function”
- Port B.3 control bit (SEG55):
 - Select “LCD segment signal output” or “general I/O function”
- Port B.4 control bit (SEG56):
 - Select “LCD segment signal output” or “general I/O function”
- Port B.5 control bit (SEG57):
 - Select “LCD segment signal output” or “general I/O function”
- Port B.6 control bit (SEG58):
 - Select “LCD segment signal output” or “general I/O function”
- Port B.7 control bit (SEG59):
 - Select “LCD segment signal output” or “general I/O function”
- Port C.0 control bit (SEG44):
 - Select “LCD segment signal output” or “general I/O function”
- Port C.1 control bit (SEG45):
 - Select “LCD segment signal output” or “general I/O function”

- Port C.2 control bit (SEG46):
 - Select “LCD segment signal output” or “general I/O function”
- Port C.3 control bit (SEG47):
 - Select “LCD segment signal output” or “general I/O function”
- Port C.4 control bit (SEG48):
 - Select “LCD segment signal output” or “general I/O function”
- Port C.5 control bit (SEG49):
 - Select “LCD segment signal output” or “general I/O function”
- Port C.6 control bit (SEG50):
 - Select “LCD segment signal output” or “general I/O function”
- Port C.7 control bit (SEG51):
 - Select “LCD segment signal output” or “general I/O function”
- Key matrix combination:
 - Select “Port A and SEG” or “Port A and Port B / Port C”
- The PA.0’s Key matrix combination:
 - Select “PA.0 and SEG” or “PA.0 and Port B / C or none”
- The PA.1’s Key matrix combination:
 - Select “PA.1 and SEG” or “PA.1 and Port B / C or none”
- The PA.2’s Key matrix combination:
 - Select “PA.2 and SEG” or “PA.2 and Port B / C or none”
- The PA.3’s Key matrix combination:
 - Select “PA.3 and SEG” or “PA.3 and Port B / C or none”

7 Function Description

7.1 Reset Function

Reset can be generated by one of the following:

- Power-on voltage detector reset and power-on reset
- WDT time out
- RSTB pin pull low

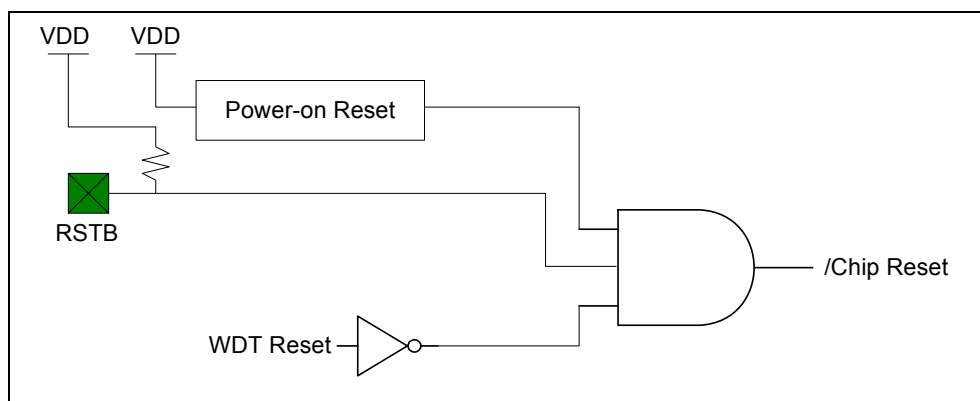

Figure 7-1 On-Chip Reset Schematic Diagram

7.1.1 Power-on Reset

The power-on reset circuit holds the device under reset condition until VDD is above Vpor (power-on reset voltage). Whenever the voltage supply is below Vpor, a reset will occur.

7.1.2 RSTB Pin

In normal condition, the RSTB pin is pulled up to VDD. Whenever the RSTB is at a Low condition (level hold or one short), a reset will occur.

- **Level Hold:** When user presses and holds the RESET key, the LSI will stop running the program. After the RESET key is released, the LSI will generate a reset signal to restart running the program.
- **One Short:** When user presses and holds the RESET key while the reset pin voltage is lower than $1/3VDD$, the LSI will generate a reset signal when the time lapses above 7.8ms, and restart running the program (see figure at right). Note that the LSI will generate a reset signal to restart running the program without having to wait for the release of the RESET key.

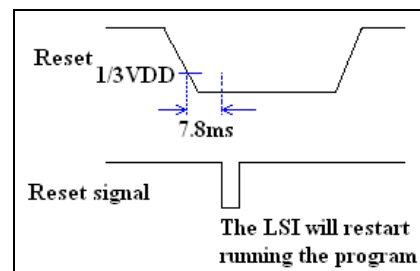

Figure 7-2 Reset Signal Timing

7.1.3 WDT Time-out

When the Watchdog Timer is enabled, the WDT time-out will cause the chip to reset. To prevent reset from occurring, the WDT value should be cleared with the “WDTC” instruction before WDT time-out. WDT time-out can also be used to flag software malfunction.

7.1.4 Status (R0Fh)

Bit 7	Bit 6	Bit 5	Bit 4	Bit 3	Bit 2	Bit 1	Bit 0
/TO	/PD	SGE	SLE	OV	Z	DC	C

Bit 0 (C): Carry flag or inverse of Borrow flag (B). Under SUB operation, Borrow flag is indicated by the inverse of Carry bit ($B = \bar{C}$).

Bit 1 (DC): Auxiliary carry flag

Bit 2 (Z): Zero flag

Bit 3 (OV): Overflow flag. Used in signed operation when Bit 6 is carried into or borrows from a signed bit (Bit 7).

Bit 4 (SLE): Computation result is less than or equal to zero (negative value) after a signed arithmetic. This is affected by HEX arithmetic instruction only.

Bit 5 (SGE): Computation result is greater than or equal to zero (positive value) after a signed arithmetic. This is affected by HEX arithmetic instruction only.

NOTE

1. When $OV=1$ after a signed arithmetic, check the SGE bit and SLE bit to verify whether overflow (carry into sign bit) or underflow (borrow from sign bit) occurred.

If $OV=1$ and $SGE=1 \rightarrow$ overflow occurred.

If $OV=1$ and $SLE=1 \rightarrow$ underflow occurred.

2. When overflow occurred, the MSB of the Accumulator should be cleared to obtain the correct value.

When underflow occurred, the MSB of the Accumulator should be set to obtain the correct value.

Example 1: ADD positive value with a positive value, and the ACC signed bit will be affected.

```
MOV    ACC, #60h    ; Signed number +60h
ADD    ACC, #70h    ; +60h ADD WITH +70h
```

Unsigned bit results after execution of the instruction:

ACC = 0D0h SGE=1, means that the result is greater than or equal to 0 (positive value)

OV=1, means that overflow occurred and the result is carried into signed bit (Bit 7)

Signed bit results after execution of the instruction:

ACC = 50h (signed bit is cleared)

The actual result = +80h (OV=1) + 50h = +0D0h

Example 2: SUB positive value from negative value, and the ACC signed bit will be affected.

```
MOV    ACC, #50h    ; Signed number +50h
SUB    ACC, #90h    ; +50h SUB from -70h (Signed number of 90h)
```

Unsigned bit results after execution of the instruction:

ACC = 40h SLE=1, Means that the result is less than or equal to 0 (negative value)

OV=1, Underflow occurred and the result borrowed from a signed bit (Bit 7)

Signed bit results after execution of the instruction:

ACC = 0C0h (the signed bit is set)

The actual result = -80h (OV=1) + 0C0h (signed number of 0C0h) = 40h

Bit 6 (/PD): Reset to “0” when /PD enters Sleep mode. Set to “1” by “WDTC” instruction, power-on reset, or by Reset pin low condition.

Bit 7 (/TO): Reset to “0” at WDT time out reset. Set to “1” by “WDTC” instruction, power-on reset, Reset pin low condition, or when the MCU enters into Sleep Mode.

When a reset occurs, the special function registers are reset to their initial value except for the /TO and /PD bits of the Status register.

Bit 7 (/TO)	Bit 6 (/PD)	Event
0	0	WDT time out reset from Sleep mode
0	1	WDT time out reset (not from Sleep mode)
1	0	Reserved
1	1	Power up or RSTB pin low condition

7.1.5 Initialization after Reset

- The oscillator is running, or will be started.
- The Watchdog timer is cleared.
- During power-on reset or RSTB pin low condition, the /TO bit and /PD bit of RF (Status) are set to “1.” At WDT time out reset, the /TO bit is cleared.
- The program counter (PCM: PCL) is clear to all “0.”
- The following table shows the other registers initial values.

7.1.5.1 Special Register

Addr.	Name	Initial Value	Addr.	Name	Initial Value
00h	INDF0	---- ---- ¹	10h	Port A	--xx xxxx
01h	FSR0	0000 0000	11h	Port B	xxxx xxxx
02h	BSR	0000 0000	12h	Port C	xxxx xxxx
03h	INDF1	---- ---- ¹	13h	General RAM	uuuu uuuu
04h	FSR1	1000 0000	14h	General RAM	uuuu uuuu
05h	BSR1	0000 0000	15h	General RAM	uuuu uuuu
06h	STKPTR	0000 0000	16h	General RAM	uuuu uuuu
07h	PCL	0000 0000	17h	General RAM	uuuu uuuu
08h	PCM	0000 0000	18h	General RAM	uuuu uuuu
09h	LCDARL	0000 0000	19h	General RAM	uuuu uuuu
0Ah	ACC	xxxx xxxx	1Ah	General RAM	uuuu uuuu
0Bh	TABPTRL	0000 0000	1Bh	General RAM	uuuu uuuu
0Ch	TABPTRM	0000 0000	1Ch	General RAM	uuuu uuuu
0Dh	TABPTRH	uuuu uuuu	1Dh	General RAM	uuuu uuuu
0Eh	LCDDATA	---- ---- ¹	1Eh	General RAM	uuuu uuuu
0Fh	STATUS	cuxx xxxx ²	1Fh	General RAM	uuuu uuuu

7.1.5.2 Control Register

Addr.	Name	Initial Value	Addr.	Name	Initial Value
20h	STBCON	0000 0000	2Bh	PAINTEN	--00 0000
21h	INTCON	---- -000	2Ch	PAINTSTA	--00 0000
22h	INTSTA	---- -000	2Dh	DCRA	--11 1111
23h	TR01CON	0000 0000	2Eh	PBCON	0000 0000
24h	TRL0L	uuuu uuuu	2Fh	DCRB	1111 1111
25h	TRL0H	uuuu uuuu	30h	PCCON	0000 0000
26h	TRL1	uuuu uuuu	31h	DCRC	1111 1111
27h	TR2WCON	0000 0000	32h	LCDCON	000- 00-0
28h	TRL2	uuuu uuuu	33h	POST_ID	-111 -000
29h	PACON	--00 0000	34h	CPUCON	---- -00c ³
2Ah	PAWAKE	--00 0000			

Legend: x: unknown -: unimplemented, read as “0”
u: unchanged, c: value depends on actual condition

¹ Not a physical register.

² If it is a power-on reset or the RSTB pin is at Low condition, the /TO bit and /PD bit of RF (Status) are set to “1.” If it is a WDT time out reset, the /TO bit is cleared and /PD bit remains unchanged.

³ Bit 0 (MS0) of R34 (CPUCON) is reloaded from “INIM” bit of code option when the MCU resets.

7.2 Oscillator System

The oscillator system is used to generate the device clock. The oscillator system is composed of an Internal RC oscillator for Slow mode and an external RC oscillator for Fast mode as shown in the diagram below.

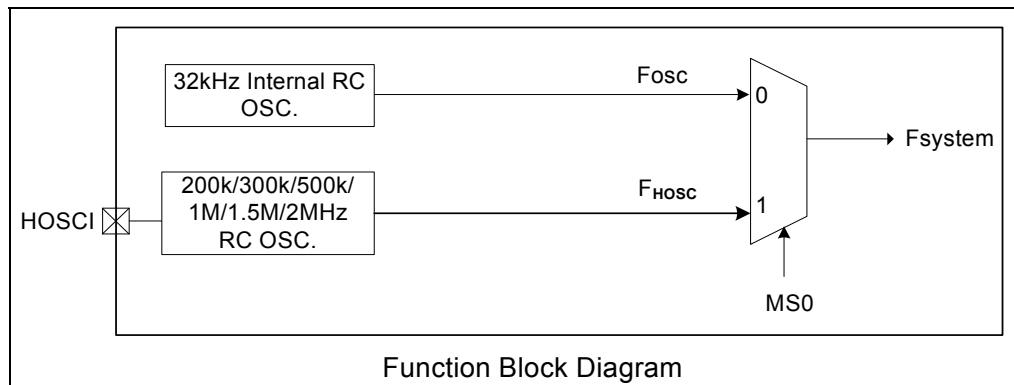

Figure 7-3 Oscillator System Function Block Diagram

The **MS0** bit (mode select bit) of **CPUCON** register (R34h) is used to set the Slow or Fast mode (see Section 7.3.1; *Slow, Fast, Sleep, and Idle Mode Operations*).

- 0: Slow mode (MCU system Clock is from Fosc)
- 1: Fast mode (MCU system Clock is from FHOSC)

7.2.1 32.8 kHz Internal RC Oscillator

A 32.8 kHz Internal RC oscillator for Slow mode.

7.2.2 200kHz/300kHz/500kHz/1MHz/1.5MHz/2MHz RC External Oscillator

A resistor should be connected between HOSCI and Vdd pin.

($\geq 1\text{MHz}$ only for $V_{DD}=2.4\sim 3.6\text{V}$)

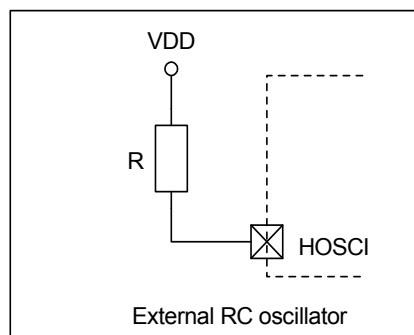

Figure 7-4 Fast Mode RC Oscillators Circuit Diagram

7.3 MCU Operation Mode

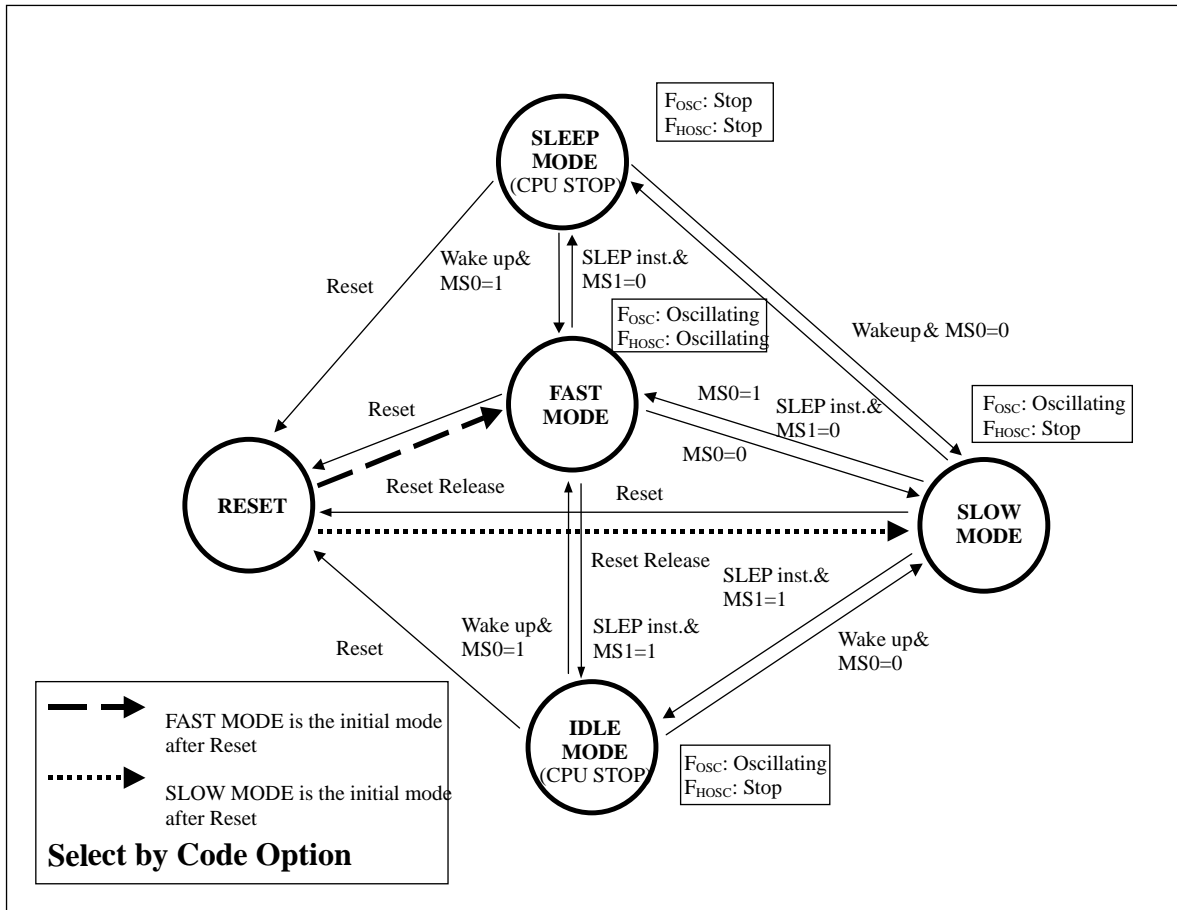

Figure 7-5 MCU Operation Block Diagram

The following table shows the supported device functions for each MCU Mode.

Device \ Mode	Sleep	Idle	Slow	Fast
Osc.(32768Hz)	×	✓	✓	✓
Fsystem	×	×	From Osc.	From Hosc.
Timers 0~2	×	×	✓	✓
INT	×*	×*	✓	✓
I/O Wake up	✓	✓	×	×
Timer 1 Wake up	×	✓	×	×

Legend: ✓ : Function is available if enabled × : Function NOT supported

* Interrupt flag will be recorded but not executed until MCU wakes up.

7.3.1 Slow, Fast, Sleep, and Idle Mode Operations

■ CPUCON (R34h): MCU Control Register

Bit 7	Bit 6	Bit 5	Bit 4	Bit 3	Bit 2	Bit 1	Bit 0
–	–	–	–	–	GLINT	MS1	MS0

Bit 0 (MS0): Select Slow Mode or Fast Mode

0: Slow Mode

1: Fast Mode

Bit 1 (MS1): Select Sleep Mode or Idle Mode after executing “SLEP” instruction.

0: Sleep Mode

1: Idle Mode

■ Slow Mode:

When the MS0 bit of the CPUCON register is set to “0,” the MCU will enter into Slow Mode and the corresponding system clock is at 32 kHz. The Slow mode feature allows performance of all system operations at reduced power consumption.

NOTE

The instruction “NOP” should be added after the “BC CPUCON, MS0” instruction when the MCU is made to enter into Slow Mode from Fast Mode. See the code example at the end of this Section.

■ Fast Mode:

When the MS0 bit of the CPUCON register is set to “1,” the MCU will enter into Fast Mode. After setting the MS0 bit, it needs to count 32 clocks from HOSC, then the system clock switches from slow to high frequency. This mode allows fast speed performance of all the system operations, but under maximum power consumption.

■ Idle Mode:

When the MS1 bit of the CPUCON register is set to “1.” and the “SLEP” instruction is executed, the MCU will enter into Idle Mode. The Idle Mode suspends all system operations except for the 32 kHz oscillator. It retains the internal status under low power consumption without stopping the clock function.

The Idle Mode is awoken by Timer 1 Wake-up or by I/O pin Wake-up (if enabled) and returns to either Slow Mode (MS0=0) or Fast Mode (MS0=1)

NOTE

All registers remain unchanged during Sleep Mode.

■ **Sleep Mode:**

When the MS1 bit of the CPUCON register is set to “0,” and the “SLEP” instruction is executed, the MCU will enter into Sleep Mode. Sleep Mode suspends all system operation and puts on hold the internal status immediately before the suspension of the operation. Sleep Mode operates under very low power consumption and is awakened by I/O pin wake up.

NOTE

- The /PD bit of the Status Register (R0Fh) is cleared when the MCU enters Sleep Mode.
- This /PD bit is set to “1” by “WDTC” instruction, power-on reset, or by RSTB pin low condition.
- All registers remain unchanged during Sleep Mode.

■ **Slow Mode to Fast Mode Timing:**

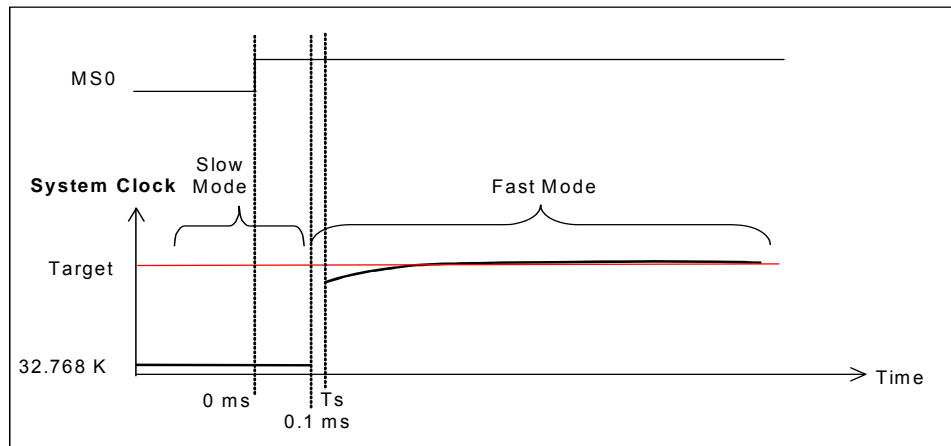

Figure 7-6 Slow Mode to Fast Mode Timing Diagram

NOTE

1. Slow Mode switches to Fast Mode at Time=0ms.
2. System clock will switch to Fast Mode after a delay of 0.1ms by oscillator and enters into Fast Mode (i.e., system clock will be at 200k ~ 2MHz).
3. High frequency RC will be stabilized at Time=Ts (around 15µs~30µs).

■ **Code Example:**

```

;Entry FAST mode
    BS    CPUCON,MS0

;Entry SLOW mode
    BC    CPUCON,MS0

;FAST mode Entry SLOW mode
    BS    CPUCON,MS0
    :
    :
    BC    CPUCON,MS0
    NOP

;Entry IDLE mode
    BS    CPUCON,MS1
    SLEP
    NOP

;Entry SLEEP mode
    BC    CPUCON,MS1
    SLEP
    NOP
    
```

7.3.2 Wake-up Operation

Oscillator is off during Sleep Mode. The MCU is awoken by input port (Port A), then returns to Fast Mode or Slow Mode (as determined by MS0 bit of CPUCON register described in previous section).

When in Idle Mode, the 32 kHz oscillator keeps on running. The MCU is awoken by input port (Port A) or Timer1, then returns to Fast Mode or Slow Mode (as determined by MS0 bit of CPUCON register described in previous section).

■ PAWAKE (R2Ah): Port A Wake-up Function Control Register

Bit 7	Bit 6	Bit 5	Bit 4	Bit 3	Bit 2	Bit 1	Bit 0
–	–	WKEN5	WKEN4	WKEN3	WKEN2	WKEN1	WKEN0

Bit 5 (WKEN5) ~ Bit 0 (WKEN0): Wake-up function control bit of Port A.5 ~ Port A.0

0: Disable Port A.5 ~ Port A.0 Wake-up function

1: Enable Port A.5 ~ Port A.0 Wake-up function

■ T1WKEN Bit of (R23h): Timer 0 and Timer 1 Control Register

Bit 7	Bit 6	Bit 5	Bit 4	Bit 3	Bit 2	Bit 1	Bit 0
T1WKEN	T1EN	T1PSR1	T1PSR0	T0EN	T0CS	T0PSR1	T0PSR0

Bit 7 (T1WKEN): Timer 1 underflow wake-up function control bit in Idle Mode

0: Disable Timer 1 Wake-up function

1: Enable Timer 1 Wake-up function.

7.4 Interrupts

When interrupt occurs, the GLINT bit of the CPUCON register is reset to “0”. It disables all interrupts, including Levels 1 ~ 5. Setting this bit to “1” will enable all un-masked interrupts.

7.4.1 Global Interrupt

■ GLINT Bit of CPUCON (R34h) MCU Control Register

Bit 7	Bit 6	Bit 5	Bit 4	Bit 3	Bit 2	Bit 1	Bit 0
–	–	–	–	–	GLINT	MS1	MS0

Bit 2 (GLINT): Global interrupt control bit

0: Disables all interrupts, including Level 1 ~ Level 5

1: Enables all un-masked interrupts

■ **Interrupt Vector**

Interrupt Level	Interrupt Source	Start Address	Remarks
–	RESET	0x00000	–
Level 1	Port A.5 ~ 0	0x00002	PAINT
Level 2	Reserved	0x00004	Reserved
Level 3	Reserved	0x00006	Reserved
Level 4	Timers 0~2	0x00008	TMR0I, TMR1I, TMR2I
Level 5	Reserved	0x0000A	Reserved

■ **Code Example:**

```

; ***** Reset program
ResetSEG CSEG      0x00
    LJMP    RESET          ;(0x00) Initialize
    LJMP    PAINT          ;(0x02) Port A Interrupt
    LJMP    RESERVED      ;(0x04) Reserved
    LJMP    RESERVED      ;(0x06) Reserved
    LJMP    TIMERINT      ;(0x08) Timer-0,1,2 Interrupt
    LJMP    RESERVED      ;(0x0A) Reserved
INT      CSEG      0x20

; --- Push interrupt register
PUSH:
    MOVPR  StatusBuf,Status
    MOV    AccBuf,A
    RET

; --- Pop interrupt register
POP:
    MOV    A,AccBuf
    MOVRP  Status,StatusBuf
    RETI

```

7.4.2 Input Port (Port A.5 ~ Port A.0) Interrupt

Port A.0 ~ Port A.5 are used as External Interrupt/Wake-Up input. If PA5IE ~ PA0IE bits of PAINTEN register are set to “1,” Port A.0 ~ Port A.5 are the external interrupt input port format.

■ **PAINTSTA (R2Ch): Port A.5 ~ Port A.0 Interrupt Status Register**

Bit 7	Bit 6	Bit 5	Bit 4	Bit 3	Bit 2	Bit 1	Bit 0
–	–	PA5I	PA4I	PA3I	PA2I	PA1I	PA0I

Bit 5 (PA5I) ~ Bit 0 (PA0I): Port A.5 ~ Port A.0 Interrupt status

Set to “1” when a pin falling edge is detected.

Clear to “0” by software

■ **PAINTEN (R2Bh): Port A.5 ~ Port A.0 Interrupt Control Register**

Bit 7	Bit 6	Bit 5	Bit 4	Bit 3	Bit 2	Bit 1	Bit 0
–	–	PA5IE	PA4IE	PA3IE	PA2IE	PA1IE	PA0IE

Bit 5 (PA5IE) ~ Bit 0 (PA0IE): PortA.5 ~ PortA.0 Interrupt control bits

0: Disable interrupts function

1: Enable interrupts function

■ **Code Example:**

```

; === Input Port A Interrupt
PAINT:
    SOCALL  PUSH
    CLR     PAINTSTA
    :
    SJMP   POP
    
```

7.4.3 Timer 0, Timer 1, and Timer 2 Interrupts

7.4.3.1 Timer 0 Interrupt

Timer 0 is a 16-bit timer used for general time counting. When the counting value underflows, Timer 0 interrupt takes place and the TRL0H: TRL0L value is reloaded into the timer automatically.

■ **TMR0IE Bit of INTCON (R21h) Timer Interrupt Control Register**

Bit 7	Bit 6	Bit 5	Bit 4	Bit 3	Bit 2	Bit 1	Bit 0
–	–	–	–	–	TMR2IE	TMR1IE	TMR0IE

Bit 0 (TMR0IE): Control bit of Timer 0 interrupt

0: Disable Timer 0 interrupt function

1: Enable Timer 0 interrupt function

■ **TMR0I Bit of INTSTA (R22h) Timer Interrupt Status Register**

Bit 7	Bit 6	Bit 5	Bit 4	Bit 3	Bit 2	Bit 1	Bit 0
–	–	–	–	–	TMR2I	TMR1I	TMR0I

Bit 0 (TMR0I): Status bit of Timer 0 interrupt

Set to “1” when Timer 0 counters underflows.

Clear to “0” by software

7.4.3.2 Timer 1 Interrupt

Timer 1 is an 8-bit timer used for time counting and Wake-up functions. When the counting value of Timer 1 underflows, interrupt occurs and the TRL1 value is reloaded to the timer.

■ **TMR1IE Bit of INTCON (R21h) Timer Interrupt Control Register**

Bit 7	Bit 6	Bit 5	Bit 4	Bit 3	Bit 2	Bit 1	Bit 0
–	–	–	–	–	TMR2IE	TMR1IE	TMR0IE

Bit 1 (TMR1IE): Control bit of Timer 1 interrupt

- 0: Disable Timer 1 interrupt function
- 1: Enable Timer 1 interrupt function

■ **TMR1I Bit of INTSTA (R22h) Timer Interrupt Status Register**

Bit 7	Bit 6	Bit 5	Bit 4	Bit 3	Bit 2	Bit 1	Bit 0
–	–	–	–	–	TMR2I	TMR1I	TMR0I

Bit 1 (TMR1I): Status bit of Timer 1 interrupt

- Set to “1” when Timer 1 counters underflows.
- Clear to “0” by software.

7.4.3.3 Timer 2 Interrupt

Timer 2 is an 8-bit timer for time counting. When the counting value of Timer 2 underflows, an interrupt occurs and the TRL2 value will be reloaded to the timer.

■ **TMR2IE Bit of INTCON (R21h) Timer Interrupt Control Register**

Bit 7	Bit 6	Bit 5	Bit 4	Bit 3	Bit 2	Bit 1	Bit 0
–	–	–	–	–	TMR2IE	TMR1IE	TMR0IE

Bit 2 (TMR2IE): Control bit of Timer 2 interrupt

- 0: Disable Timer 2 interrupt function
- 1: Enable Timer 2 interrupt function

■ **TMR2I Bit of INTSTA (R22h) Timer Interrupt Status Register**

Bit 7	Bit 6	Bit 5	Bit 4	Bit 3	Bit 2	Bit 1	Bit 0
–	–	–	–	–	TMR2I	TMR1I	TMR0I

Bit 2 (TMR2I): Status bit of Time 2 interrupt

- Set to “1” when Timer 2 Counter underflows.
- Clear to “0” by software.

7.4.3.4 Code Example:

```

; === Timer-0,1,2 Interrupt
TIMERINT:
    S0CALL PUSH
    JBS    INTSTA,TMR0I,toTM0INT
    JBS    INTSTA,TMR1I,toTM1INT
    JBS    INTSTA,TMR2I,toTM2INT
    SJMP  POP

; --- Timer 0 Interrupt
toTM0INT:
    BC    INTSTA,TMR0I
    :
    SJMP  POP

; --- Timer 1 Interrupt
toTM1INT:
    BC    INTSTA,TMR1I
    :
    SJMP  POP

; --- Timer 2 Interrupt
toTM2INT:
    BC    INTSTA,TMR2I
    :
    SJMP  POP
    
```

7.5 Program ROM Map

ROM Size = 24K Words	
Address.	Description
0000h ┆ 000Bh	Interrupt Vector (12 words)
000Ch ┆ 000Fh	Code Option (4 words)
0010h ┆ 001Fh	Test Program (16 words)
0020h ┆ 5FFFh	Program or Fixed data region

7.6 RAM Map for Special and Control Registers

RAM Size: 88 Bytes + 16 Banks × 128 Bytes = 2136 Bytes

7.6.1 Special and Control Registers

Legend: R = Readable bit W = Writable bit – = Not implemented

Addr.	Register Name	Bit 7	Bit 6	Bit 5	Bit 4	Bit 3	Bit 2	Bit 1	Bit 0
0	INDF0	R/W Indirect Addressing Pointer 0							
1	FSR0	R/W File Select Register 0 for INDF0 (R0)							
2	BSR	R Fixed 0	R Fixed 0	R Fixed 0	R Fixed 0	R/W	R/W	R/W	R/W
Bank select register (for INDF0 & general)									
3	INDF1	R/W Indirect Addressing Pointer 1							
4	FSR1	R Fixed 1	R/W	R/W	R/W	R/W	R/W	R/W	R/W
File Select Register 1 for INDF1 (R3)									
5	BSR1	R Fixed 0	R Fixed 0	R Fixed 0	R Fixed 0	R/W	R/W	R/W	R/W
Bank select Register 1 (for INDF1)									
6	STKPTR	R/W Stack Pointer							
7	PCL	R/W PC7	R/W PC6	R/W PC5	R/W PC4	R/W PC3	R/W PC2	R/W PC1	R/W PC0
8	PCM	R Fixed 0	R/W PC14	R/W PC13	R/W PC12	R/W PC11	R/W PC10	R/W PC9	R/W PC8
9	LCDARL	R/W LCD RAM Column Address							
A	ACC	R/W Accumulator							
B	TABPTRL	R/W Low Byte of Table Pointer							
C	TABPTRM	R/W Middle Byte of Table Pointer							
D	TABPTRH	R/W							
E	LCDDATA	R/W Indirect Register to LCD RAM							
F	STATUS	R /TO	R /PD	R/W SGE	R/W SLE	R/W OV	R/W Z	R/W DC	R/W C
10	Port A	–	–	R/W Port A.5	R/W Port A.4	R/W Port A.3	R/W Port A.2	R/W Port A.1	R/W Port A.0
11	Port B	R/W Port B.7	R/W Port B.6	R/W Port B.5	R/W Port B.4	R/W Port B.3	R/W Port B.2	R/W Port B.1	R/W Port B.0
12	Port C	R/W Port C.7	R/W Port C.6	R/W Port C.5	R/W Port C.4	R/W Port C.3	R/W Port C.2	R/W Port C.1	R/W Port C.0

(Continuation)

Addr.	Register Name	Bit 7	Bit 6	Bit 5	Bit 4	Bit 3	Bit 2	Bit 1	Bit 0
20	STBCON	R/W	R/W	R/W	R/W	R/W	R/W	R/W	R/W
		SCAN	KE	R1EN	BitST	STB3	STB2	STB1	STB0
21	INTCON	–	–	–	–	–	R/W	R/W	R/W
		–	–	–	–	–	TMR2IE	TMR1IE	TMR0IE
22	INTSTA	–	–	–	–	–	R/W	R/W	R/W
		–	–	–	–	–	TMR2I	TMR1I	TMR0I
23	TR01CON	R/W	R/W	R/W	R/W	R/W	R/W	R/W	R/W
		T1WKEN	T1EN	T1PSR1	T1PSR0	T0EN	T0CS	T0PSR1	T0PSR0
24	TRL0L	R/W Timer 0 Auto-reload Register Low Byte							
25	TRL0H	R/W Timer 0 Auto-reload Register High Byte							
26	TRL1	R/W Timer 1 Auto-reload Register							
27	TR2WCON	R/W	–	R/W	R/W	R/W	R/W	R/W	R/W
		WDTEN	–	WDTPSR1	WDTPSR0	T2EN	T2CS	T2PSR1	T2PSR0
28	TRL2	R/W Timer 2 Auto-reload Register							
29	PACON	–	–	R/W	R/W	R/W	R/W	R/W	R/W
		–	–	PA5PU	PA4PU	PA3PU	PA2PU	PA1PU	PA0PU
2A	PAWAKE	–	–	R/W	R/W	R/W	R/W	R/W	R/W
		–	–	WKEN5	WKEN4	WKEN3	WKEN2	WKEN1	WKEN0
2B	PAINTEN	–	–	R/W	R/W	R/W	R/W	R/W	R/W
		–	–	PA5IE	PA4IE	PA3IE	PA2IE	PA1IE	PA0IE
2C	PAINTSTA	–	–	R/W	R/W	R/W	R/W	R/W	R/W
		–	–	PA5I	PA4I	PA3I	PA2I	PA1I	PA0I
2D	DCRA	–	–	R/W	R/W	R/W	R/W	R/W	R/W
		–	–	PA5DC	PA4DC	PA3DC	PA2DC	PA1DC	PA0DC
2E	PBCON	R/W	R/W	R/W	R/W	R/W	R/W	R/W	R/W
		PB7PU	PB6PU	PB5PU	PB4PU	PB3PU	PB2PU	PB1PU	PB0PU
2F	DCRB	R/W	R/W	R/W	R/W	R/W	R/W	R/W	R/W
		PB7DC	PB6DC	PB5DC	PB4DC	PB3DC	PB2DC	PB1DC	PB0DC
30	PCCON	R/W	R/W	R/W	R/W	R/W	R/W	R/W	R/W
		PC7PU	PC6PU	PC5PU	PC4PU	PC3PU	PC2PU	PC1PU	PC0PU
31	DCRC	R/W	R/W	R/W	R/W	R/W	R/W	R/W	R/W
		PC7DC	PC6DC	PC5DC	PC4DC	PC3DC	PC2DC	PC1DC	PC0DC
32	LCDCON	–	R/W	R/W	–	R/W	R/W	–	R/W
		–	BLANK	LCDON	–	LCR1	LCR0	–	LBVON
33	POST_ID	–	R/W	R/W	R/W	–	R/W	R/W	R/W
		–	LCD_ID	FSR1_ID	FSR0_ID	–	LCD_PE	FSR1_PE	FSR0_PE
34	CPUCON	–	–	–	–	–	R/W	R/W	R/W
		–	–	–	–	–	GLINT	MS1	MS0

7.6.2 Other Unbanked General RAM

Address	Unbanked
13h ┆ 1Fh	General purpose RAM
35h ┆ 7Fh	General purpose RAM

7.6.3 Banked General RAM

Address	Bank 0	Bank 1	Bank 2	Bank 3	Bank 15
80h ┆ FFh	General Purpose RAM	General Purpose RAM	General Purpose RAM	General Purpose RAM	General Purpose RAM

7.7 LCD RAM Map

■ 1/5 Duty

RAM Address		COM0	COM1	COM2	COM3	COM4	-	-	-
LCDARL		Bit 0	Bit 1	Bit 2	Bit 3	Bit 4	Bit 5	Bit 6	Bit 7
SEG0	00H								
:	:								
SEG59	3BH								

■ 1/9 Duty

RAM Address		COM0	COM1	COM2	COM3	COM4	COM5	COM6	COM7
LCDARL		Bit 0	Bit 1	Bit 2	Bit 3	Bit 4	Bit 5	Bit 6	Bit 7
SEG0	00H								
:	:								
SEG59	3BH								

RAM Address		COM8	-	-	-	-	-	-	-
LCDARL		Bit 0	Bit 1	Bit 2	Bit 3	Bit 4	Bit 5	Bit 6	Bit 7
SEG0	40H								
:	:								
SEG59	7BH								

7.8 Special Function Registers

7.8.1 ACC (R0Ah): Accumulator

Internal data transfer operation, or instruction operand holding usually involves the temporary storage function of the Accumulator, which is not an addressable register.

7.8.2 POST_ID (R33h): Post Increase / Decrease Control Register

Bit 7	Bit 6	Bit 5	Bit 4	Bit 3	Bit 2	Bit 1	Bit 0
–	LCD_ID	FSR1_ID	FSR0_ID	–	LCDPE	FSR1PE	FSR0PE

Bit 0 (FSR0PE): Enable FSR0 post increase/decrease function. FSR0 will NOT carry into or borrow from BSR.

Bit 1 (FSR1PE): Enable FSR1 post increase/decrease function. FSR1 will carry into or borrow from BSR1.

Bit 4 (FSR0_ID): 0: Auto decrease FSR0
1: Auto increase FSR0

Bit 5 (FSR1_ID): 0: Auto decrease FSR1
1: Auto increase FSR1

7.8.3 BSR, FSR0, INDF0 (R02h, R01h, R00h): Indirect Address Pointer 0 Registers

BSR (R02h) Determines which bank is active (working bank) among the 16 banks (Bank 0 ~ Bank 15).

FSR0 (R01h) Is an address register for INDF0. Up to 256 bytes (Address: 00 ~ 0FFh) can be selected.

INDF0 (R00h) Is not a physically implemented register.

7.8.4 BSR1, FSR1, INDF1 (R05h, R04h, R03h): Indirect Address Pointer 1 Registers

BSR1 (R05h) Is a bank register for INDF1. It cannot determine the working bank for the general register.

FSR1 (R04h) Is an address register for INDF1. Up to 128 bytes (Address: 80 ~ 0FFh) can be selected. Bit 7 of FSR1 is fixed to "1."

INDF1 (R03h) Is not a physically implemented register.

■ Code Example 1:

```

Data transform Bank 0 to Bank 1:
MOV    A,#00110011B           ; Enable FSR0 & FSR1 post increase
MOV    POST_ID,A
BANK   #0                      ; BSR = 0 working Bank
MOV    A,#1
MOV    BSR1,A                  ; BSR1 = 1 is Bank 1
MOV    A,#80H
MOV    FSR0,A                  ; FSR0 = 80H
CLR    FSR1                    ; FSR1 = 80H
MOV    A,#80H
RPT    ACC
MOV    INDF1,INDF0             ; Move 80H ~ 0FFH data to Bank 1
:

```

■ INDF1 Linear Address Capabilities

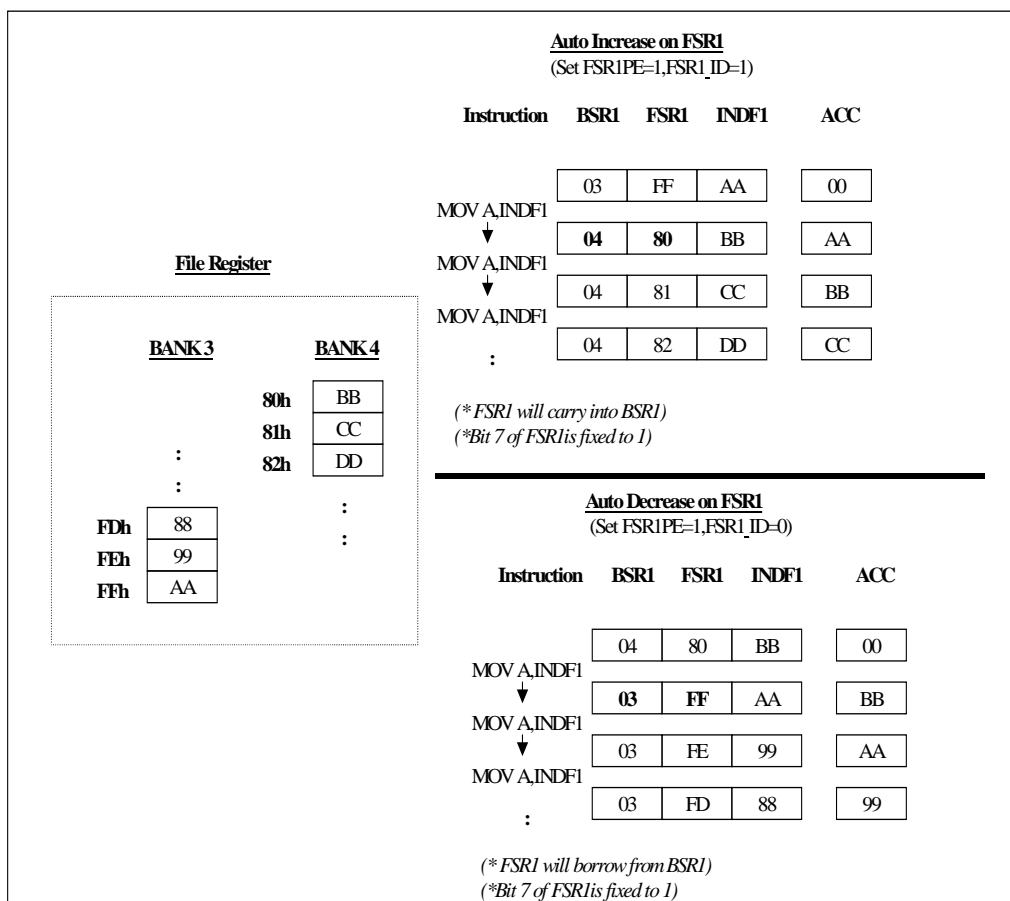

Figure 7-7 INDF1 Linear Address Capabilities Diagram

■ Code Example 2:

```

;*****
;*  Const => Working bank setting
;*  REG => Save or Recall register
;*****
;  ****  RAM stack macro
;  ***  Initial RAM stack
IniRAMsk MACRO  #Const
    MOV    A,#Const
    MOV    BSR1,A
    CLR    FSR1
    BS     POST_ID,FSR1PE
    ENDM
;  ***  Push RAM stack
PushRAM MACRO  REG
    BS     POST_ID,FSR1_ID
    MOV    INDF1,REG
    ENDM
;  ***  Pop RAM stack
PopRAM MACRO  REG
    BC     POST_ID,FSR1_ID
    MOV    REG,INDF1
    ENDM
;  ***  Main start program
Mstart:
    :
    :
    IniRAMsk #29
    :
    :
MnLoop:
    :
    :
    LJMP  MnLoop
;  ***  Interrupt routine
IntSR:
    PushRAM ACC
    PushRAM Status
    :
    :
    :
    PopRAM Status
    PopRAM ACC
    RETI
    
```

7.8.5 STKPTR (R06h): Stack Pointer Register

The initial stack pointer is 00h. Each INT/CALL will stack two bytes of address with a total capacity of 32 levels. When stack overflows, it will replace the first stack level.

NOTE

This Bank RAM does not include the stack RAM. The stack RAM is independent and cannot be seen.

7.8.6 PCL, PCM (R07h, R08h): Program Counter Registers

Bit15	Bit14	Bit13	Bit12	Bit11	Bit10	Bit9	Bit8	Bit7	Bit6	Bit5	Bit4	Bit3	Bit2	Bit1	Bit0
-	PCM							PCL							

The configuration structure can generate up to 24K×16 on-chip ROM addresses for the relative programming instruction codes.

“S0CALL” loads the low 12 bits of the PC (4K×16 ROM)

“SCALL” or “SJMP” loads the low 13 bits of the PC (8K×16 ROM)

“LCALL” or “LJMP” loads the full 14 bits of the PC (24K×16 ROM)

“ADD R7, A” or “ADC R7, A” allows a relative address to be added into the current PC. The carry bit of R7 will automatically carry into PCM.

■ **Code Example:**

```

START:
    MOV    A,entry
    MOV    number,A                ; Number ← entry
    LCALL  Indirect_JUMP
AAA:
    :
    :
Indirect_JUMP:
    MOV    A,number
    ADD    A,ACC                   ; A ← 2*A
    ADD    PCL,A                   ; PCL ← PCL+A
Function_table:
    LJMP  Function_Address_1      ; Number=0
    LJMP  Function_Address_2      ; Number=1
    LJMP  Function_Address_3      ; Number=2
    LJMP  Function_Address_4      ; Number=3
    LJMP  Function_Address_5      ; Number=4
    LJMP  Function_Address_6      ; Number=5
    LJMP  Function_Address_7      ; Number=6
    :
Function_Address_1:
    :                               ; Function 1 operation
    :
    RET                               ; PC will return to AAA label

```

7.8.7 TABPTRL, TABPTRM (R0Bh, R0Ch): Table Pointer Registers

Bit15	Bit14	Bit13	Bit12	Bit11	Bit10	Bit9	Bit8	Bit7	Bit6	Bit5	Bit4	Bit3	Bit2	Bit1	Bit0
TABPTRM								TABPTRL							

Program ROM or Internal ROM address register.

Bit 15 ~ Bit 1 are used to point the memory address.

Bit 0 is used to select low byte or high byte (see TBRD instruction in the Instruction Set under Section 12)

■ **Code Example:**

```

; *** Program ROM
:
:
TBPTM  #(PROMTabB*2)/100H
TBPTL  #PROMTabB*2
:
:
TBRD   0,ACC                ; No change
TBRD   1,ACC                ; Auto-increase
TBRD   2,ACC                ; Auto-decrease
:
:
; *** Program ROM data
PROMTabB:
DB     0x00,0x01,0x02,0x03,0x04,0x05
DB     0x10,0x11,0x12,0x13,0x14,0x15
DB     0x20,0x21,0x22,0x23,0x24,0x25

```

7.8.8 Port A, Port B, Port C (R10h, R11h, R12h): General I/O Pin Registers

Port A (R10h) Port A.0 ~ 5 are general I/O pin registers.

Port B (R11h) Port B.0 ~ 7 are general I/O pin registers.

Port C (R12h) Port C.0 ~ 7 are general I/O pin registers.

7.8.9 STBCON (R20): Strobe Output Control Register

Bit 7	Bit 6	Bit 5	Bit 4	Bit 3	Bit 2	Bit 1	Bit 0
SCAN	KE	R1EN	BitST	STB3	STB2	STB1	STB0

Bit 7 (SCAN): Automatic key scan or specify the scan signal bit by bit

0: Key scan is specified as “Bits STB3 ~ 0 defined”

1: Auto strobe scanning

Bit 6 (KE): Low nibble key input enable/disable control bit

0: Disable Low nibble key input function (Port A.0~3 do not correspond with Key input in software scan mode)

1: Enable Low nibble key input function (Port A.0~3 correspond with Key input in software scan mode)

Bit 5 (R1EN): R1 pull up resistor (small resistor) control bit for Port A.3 ~ Port A.0.

0: Disable R1 pull up resistor

1: Enable R1 pull up resistor

Bit 4 (BitST): Enable SEG0 ~ SEG15 as key strobe pins

0: SEG0 ~ SEG15 are used as LCD segment signal pins only.

1: SEG0 ~ SEG15 are used as key strobe pins and LCD segment pins.
Strobe signal is STB3 ~ 0 defined.

Bits 3 ~ 0 (STB3 ~ 0): 16 to 1 multiplexing selector of key strobe pin

7.8.10 PACON (R29h): Port A Control Register

Bit 7	Bit 6	Bit 5	Bit 4	Bit 3	Bit 2	Bit 1	Bit 0
–	–	PA5PU	PA4PU	PA3PU	PA2PU	PA1PU	PA0PU

Bit 5 ~ Bit 0 (PA5PU ~ PA0PU): Enable PortA.0 ~ Port A.5 pull-up resistor bits

0: Disable Port A.0 ~ Port A.5 pull-up resistor

1: Enable Port A.0 ~ Port A.5 pull-up resistor

7.8.11 PAWAKE (R2Ah): Port A Wake-up Control Register

Bit 7	Bit 6	Bit 5	Bit 4	Bit 3	Bit 2	Bit 1	Bit 0
–	–	WKEN5	WKEN4	WKEN3	WKEN2	WKEN1	WKEN0

Bit 5 ~ Bit 0 (WKEN5 ~ WKEN0): Wake-up enable control bits of Port A.5~Port A.0

0: Disable Port A.5 ~ Port A.0 wake-up function

1: Enable Port A.5 ~ Port A.0 wake-up function

NOTE

This function is only available with Port A selected as input pin.

7.8.12 PAINTEN (R2Bh): Port A Interrupt Enable Control Register

Bit 7	Bit 6	Bit 5	Bit 4	Bit 3	Bit 2	Bit 1	Bit 0
–	–	PA5IE	PA4IE	PA3IE	PA2IE	PA1IE	PA0IE

Bit 5 ~ Bit 0 (PA5IE ~ PA0IE): Interrupt Control bits of Port A.5~Port A.0

0: Disable Port A interrupt function

1: Enable Port A interrupt function

NOTE

This function is only available with Port A selected as input pin.

7.8.13 PAINTSTA (R2Ch): Port A Interrupt Status Register

Bit 7	Bit 6	Bit 5	Bit 4	Bit 3	Bit 2	Bit 1	Bit 0
–	–	PA5I	PA4I	PA3I	PA2I	PA1I	PA0I

Bit 5 ~ Bit 0 (PA5I ~ PA0I): INT status of Port A.5 ~ Port A.0 interrupts bits

Set to “1” when pin falling edge is detected

Cleared (“0”) by software

7.8.14 DCRA (R2Dh): Port A Direction Control Register

Bit 7	Bit 6	Bit 5	Bit 4	Bit 3	Bit 2	Bit 1	Bit 0
–	–	PA5DC	PA4DC	PA3DC	PA2DC	PA1DC	PA0DC

Bit 5 ~ Bit 4 (PA5DC ~ PA4DC): PortA.5 ~ PortA.0 direction control bits

0: Set to output pin

1: Set to input pin

7.8.15 PBCON (R2Eh): Port B Pull up Resistor Control Register

Bit 7	Bit 6	Bit 5	Bit 4	Bit 3	Bit 2	Bit 1	Bit 0
PB7PU	PB6PU	PB5PU	PB4PU	PB3PU	PB2PU	PB1PU	PB0PU

Bit 7 ~ Bit 0 (PB7PU ~ PB0PU): Port B.0 ~ Port B.7 pull-up resistor control bits

0: Disable pull-up resistor

1: Enable pull-up resistor

NOTE

This function is only available with Port B selected as input pin.

7.8.16 DCRB (R2Fh): Port B Direction Control Register

Bit 7	Bit 6	Bit 5	Bit 4	Bit 3	Bit 2	Bit 1	Bit 0
PB7DC	PB6DC	PB5DC	PB4DC	PB3DC	PB2DC	PB1DC	PB0DC

Bit 7 ~ Bit 0 (PB7DC ~ PB0DC): Port B.0 ~PortB.7 direction control bits

0: Set to output pin

1: Set to input pin

NOTE

When Port B bit is set to input pin, a 5μsec delay in reading Port B data must be provided. Otherwise, read data will be inaccurate. See Example below.

■ **Code Example:**

```

; *** Set Port B to input pins
MOV     A,#0XFF
MOV     DCRB,A
MOV     PBCON,A
Read_PB:
JBS     PORTB,0,Read_PB
        Delay 5usec
JBS     PORTB,0,Read_PB
SJMP   Read_PB
    
```

7.8.17 PCCON (R30h): Port C Pull up Resistor Control Register

Bit 7	Bit 6	Bit 5	Bit 4	Bit 3	Bit 2	Bit 1	Bit 0
PC7PU	PC6PU	PC5PU	PC4PU	PC3PU	PC2PU	PC1PU	PC0PU

Bit 7 ~ Bit 0 (PC7PU ~ PC0PU): PortC.0 ~ PortC.7 pull up resistor control bits

0: Disable pull up resistor

1: Enable pull up resistor

NOTE

This function is only available with the Port C selected as input pin.

7.8.18 DCRC (R31h): Port C Direction Control Register

Bit 7	Bit 6	Bit 5	Bit 4	Bit 3	Bit 2	Bit 1	Bit 0
PC7DC	PC6DC	PC5DC	PC4DC	PC3DC	PC2DC	PC1DC	PC0DC

Bit 7 ~ Bit 0 (PC7DC ~ PC0DC): Port C.0 ~ PortC.7 direction control bits

0: Set to output pin

1: Set to input pin

NOTE

When a PortC bit is set to input pin, a 5 μ sec delay in reading the PortC data must be provided. Otherwise, read data will be inaccurate. See example below.

■ **Code Example:**

```

; *** Set PortC to input pins
MOV    A,#0XFF
MOV    DCRC,A
MOV    PCCON,A
Read_PC:
JBS    PORTC,0,Read_PC
      Delay 5usec
JBS    PORTC,0,Read_PC
SJMP   Read_PC

```

8 Peripheral

8.1 Timer 0 (16 Bits Timer with Event Counter Function)

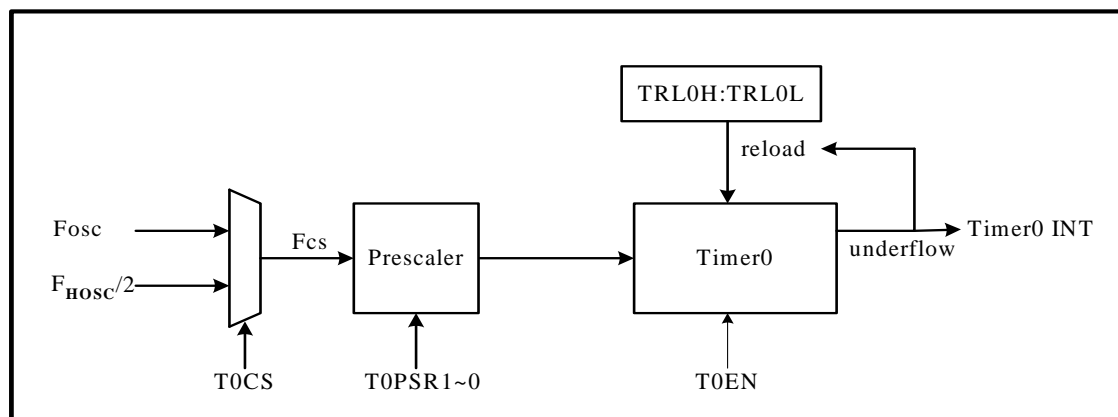

Figure 8-1 Timer 0 Function Block Diagram

Timer 0 is a general-purpose 16-bit down counter used on applications that require time counting with interrupt. The clock source (F_{CS}) is selectable from the oscillator clock (F_{osc}) or half of the system clock (F_{Hosc}).

A prescaler for the timer is also provided. The $T0PSR1 \sim T0PSR0$ bits of $TR01CON$ register determine the prescaler ratio and generate different clock rates as clock source for the timer.

The Counter value is decremented by one (count down) according to the timer clock source frequency. When underflow occurs, the timer interrupt is triggered if the global interrupt and Timer 0 interrupt are both enabled. At the same time, $TRL0H:TRL0L$ will automatically be reloaded into the 16-bit counter.

$$T = \frac{1}{F_{CS}} \times Prescaler \times (TRL0H : TRL0L + 1)$$

8.1.1 Timer 0 Registers

■ $TRL0H:TRL0L$ (R25h, R24h): Timer 0 Reload Registers

Reloaded registers are used to store the auto-reload value of Timer 0. When Timer 0 is enabled or underflow occurs, $TRL0H:TRL0L$ register values will automatically be reloaded into the 16-bit counter.

■ **TR01CON (R23h): Timer 0 and Timer 1 Control Register**

Bit 7	Bit 6	Bit 5	Bit 4	Bit 3	Bit 2	Bit 1	Bit 0
T1WKEN	T1EN	T1PSR1	T1PSR0	T0EN	T0CS	T0PSR1	T0PSR0

Bit 3 (T0EN): Timer 0 enable control bit

- 0: Disable
- 1: Enable

Bit 2 (T0CS): Timer 0 clock source select bit

- 0: Clock source is from FOSC.
- 1: Clock source is from FHOSC/2.

Bit 1 ~ Bit 0 (T0PSR1 ~ T0PSR0): Timer 0 prescaler select bits

T0PSR1: T0PSR0	Prescaler Value
00	1:1
01	1:4
10	1:16
11	1:64

■ **CPUCON (R34h): MCU Control Register**

Bit 7	Bit 6	Bit 5	Bit 4	Bit 3	Bit 2	Bit 1	Bit 0
–	–	–	–	–	GLINT	MS1	MS0

Bit 2 (GLINT): Global interrupt enable/disable bit

- 0: Disable all interrupts
- 1: Enable all un-mask interrupts

■ **INTCON (R21h): Timer Interrupt Control Register**

Bit 7	Bit 6	Bit 5	Bit 4	Bit 3	Bit 2	Bit 1	Bit 0
–	–	–	–	–	TMR2IE	TMR1IE	TMR0IE

Bit 0 (TMR0IE): Timer 0 interrupt control bit

- 0: Disable interrupt function
- 1: Enable interrupt function

■ INTSTA (R22h): Timer Interrupt Status Register

Bit 7	Bit 6	Bit 5	Bit 4	Bit 3	Bit 2	Bit 1	Bit 0
-	-	-	-	-	TMR2I	TMR1I	TMR0I

Bit 0 (TMR0I): When Timer 0 interrupt occurs, this bit will be set, and Cleared to “0” by software.

● Code Example:

```

; === Timer 0 interrupt
TIMERINT:
    PUSH
    JBC    INTSTA,TMR0I,Q_Time
    BC    INTSTA,TMR0I
    BTG    PORT A,5
Q_Time:
    POP
    RETI
; === Timer0 = [1/(300K/2)] * [1 x(1FFFh + 1)]
Timer0SR:
    :
    ; System setting 300KHz
    ; PA.5 setting output pin
    :
    MOV    A,#0B00000100
    AND    TR01CON,A                ; Fhosc & Pre-scale 1:1
    MOV    A,#0X1F
    MOV    TRLOH,A
    MOV    A,#0XFF
    MOV    TRLOL,A                ; 13.65ms=[1x(8191 + 1)/(300K/2)
    BS    TR01CON,T0EN            ; Timer 0 enable
    BS    INTCON,TMR0IE          ; Timer 0 interrupt enable
    BC    INTSTA,TMR0I           ; Clear Timer 0 interrupt status
    BS    CPUCON,GLINT           ; Enable global interrupt
TimeLoop:
    SJMP    TimeLoop
    
```

8.2 Timer 1 (8 Bits)

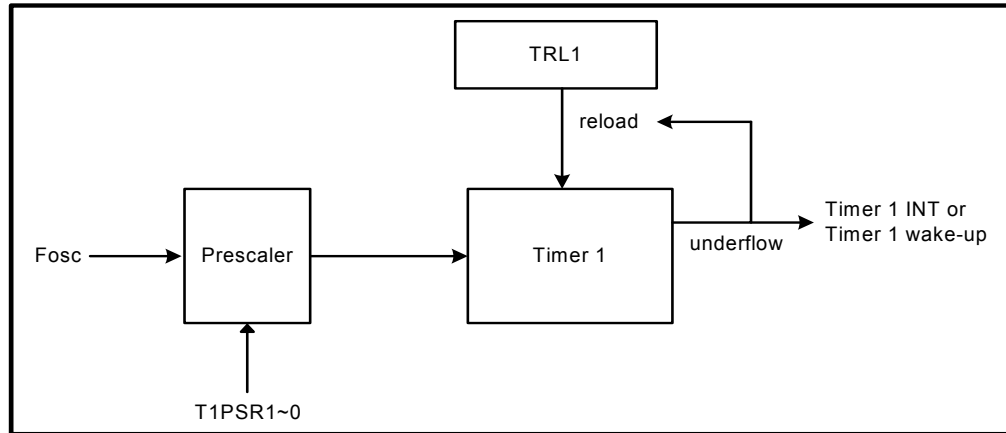

Figure 8-2 Timer 1 Function Block Diagram

Timer 1 is a general-purpose 8-bit down counter used on applications that require time counting with interrupt and wake-up functions. The clock source is from the oscillator clock (F_{osc}).

A prescaler for the timer is also available. The T1PSR1 ~ T1PSR0 bits of TR01CON register determine the pre-scale ratio and generate different clock rates as clock source for the timer. Setting T1WKEN bit of TR01CON register to “1” will enable the Timer 1 underflow wake-up function in Idle Mode.

The Counter value will be decremented by one (count down) according to timer clock source frequency. When the counter underflows, the timer interrupt is triggered if the global interrupt and Timer 1 interrupt are both enabled. At the same time, TRL1 value will be automatically reloaded into the 8-bit counter.

$$T = \frac{1}{F_{OSC}} \times Prescaler \times (TRL1 + 1)$$

8.2.1 Timer 1 Registers

■ TRL1 (R26h): Timer 1 Reload Register

This register is used to store the auto-reload value of Timer 1. When Timer 1 is enabled or underflow occurs, TRL1 register value will be automatically reloaded into the 8-bit counter.

■ CPUCON (R34h): MCU Control Register

Bit 7	Bit 6	Bit 5	Bit 4	Bit 3	Bit 2	Bit 1	Bit 0
–	–	–	–	–	GLINT	MS1	MS0

Bit 2 (GLINT): Global interrupt enable/disable bit
0: Disable all interrupt
1: Enable all un-mask interrupt

■ TR01CON (R23h): Timer 0 and Timer 1 Control Register

Bit 7	Bit 6	Bit 5	Bit 4	Bit 3	Bit 2	Bit 1	Bit 0
T1WKEN	T1EN	T1PSR1	T1PSR0	T0EN	T0CS	T0PSR1	T0PSR0

Bit 7 (T1WKEN): Enable bit of Timer 1 underflow Wake-up function in Idle Mode
0: Disable Timer 1 Wake-up function
1: Enable Timer 1 Wake-up function

Bit 6 (T1EN): Timer 1 enable control bit
0: Disable Timer 1 (stop counting)
1: Enable Timer 1

Bit 5 ~ Bit 4 (T1PSR1 ~ T1PSR0): Timer 1 prescaler select bits

T1PSR1: T1PSR0	Prescaler Value
00	1:4
01	1:16
10	1:64
11	1:256

■ INTCON (R21h): Timer Interrupt Control Register

Bit 7	Bit 6	Bit 5	Bit 4	Bit 3	Bit 2	Bit 1	Bit 0
–	–	–	–	–	TMR2IE	TMR1IE	TMR0IE

Bit 1 (TMR1IE): Control bit of Timer 1 interrupt
0: Disable Interrupt function
1: Enable Interrupt function

■ INTSTA (R22h): Timer Interrupt Status Register

Bit 7	Bit 6	Bit 5	Bit 4	Bit 3	Bit 2	Bit 1	Bit 0
–	–	–	–	–	TMR2I	TMR1I	TMR0I

Bit 1 (TMR1I): When Timer 1 interrupt occurs, this bit will be set, and cleared to “0” by software.

● **Code Example:**

```

; === Timer 1 interrupt
TIMERINT:
    PUSH
    JBC    INTSTA,TMR1I,Q_Time
    BC    INTSTA,TMR1I
    BTG    Port A,5
Q_Time:
    POP
    RETI
; === Timer1 = 32.768K / [256 x (3Fh + 1)]
Timer1SR:
    :
    ; PA.5 setting output pin
    :
    MOV    A,#10110000B
    MOV    TMR1CON,A                ; Fosc & Pre-scale 1:256 & wakeup
    MOV    A,#03FH
    MOV    TRL1,A                    ; 0.5sec=[256x(63+1)]/32.768K
    BS    TMR1CON,T1EN              ; Timer 1 enable
    BS    INTCON,TMR1IE             ; Timer 1 interrupt enable
    BC    INTSTA,TMR1I              ; Clear Timer 1 interrupt status
    BS    CPUCON,GLINT              ; Enable global interrupt
    BS    CPUCON,MS1                ; Idle mode
T1Wloop:
    SLEP
    NOP
    :
    SJMP  T1Wloop

```

8.3 Timer 2 (8 Bits)

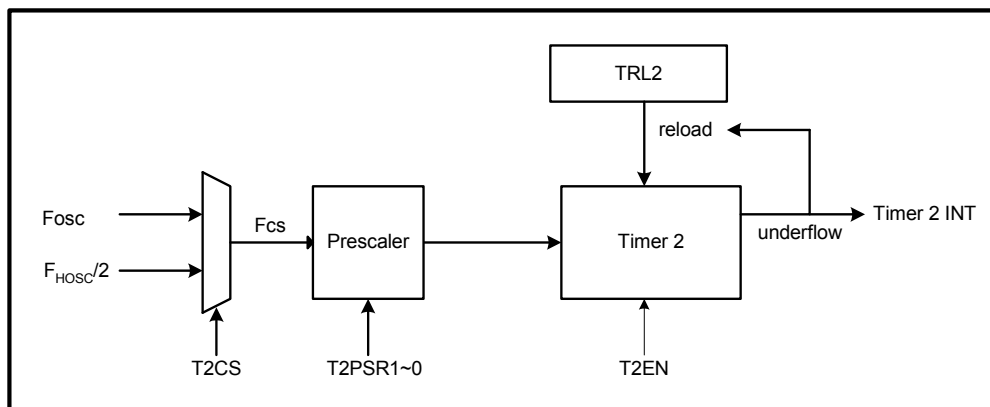

Figure 8-3 Timer 2 Function Block Diagram

Timer 2 is a general-purpose 8-bit down counter used on applications that require a time counter with interrupt. The clock source (Fcs) may be selected from the oscillator clock (Fosc) or half of the system clock (F_{Hosc}/2).

A prescaler for the timer is also available. The T2PSR1 ~ T2PSR0 bits of TR2WCON register determine the prescaler ratio and generate different clock rates as clock source for the timer.

Counter value is decreased by one (counting down) according to the timer clock source frequency. When counter value underflows, the timer interrupt is triggered (if Timer 2 interrupt is enabled).

$$T = \frac{1}{F_{CS}} \times \text{Prescaler} \times (TRL2 + 1)$$

8.3.1 Timer 2 Registers

■ TRL2 (R28h): Timer 2 Reload Register

This register is used to store the auto-reload value of Timer 2. When Timer 2 is enabled or underflow occurs, TRL2 register value will be automatically reloaded into the 8-bit counter.

■ TR2WCON (R27h): Timer 2/Watchdog Timer Control Register

Bit 7	Bit 6	Bit 5	Bit 4	Bit 3	Bit 2	Bit 1	Bit 0
WDTEN	–	WDTPSR1	WDTPSR0	T2EN	T2CS	T2PSR1	T2PSR0

Bit 3 (T2EN): Timer 2 enable control bits

- 0: Disable Timer 2 (stop counting)
- 1: Enable Timer 2

Bit 2 (T2CS): Timer 2 Clock source select bit

- 0: Clock source is from FOSC
- 1: Clock source is from FHOSC/2

Bit 1 ~ Bit 0 (T2PSR1 ~ T2PSR0): Timer 2 Prescaler Select Bits

T2PSR1: T2PSR0	Prescaler Value
00	1:1
01	1:2
10	1:4
11	1:8

■ **CPUCON (R34h): MCU Control Register**

Bit 7	Bit 6	Bit 5	Bit 4	Bit 3	Bit 2	Bit 1	Bit 0
-	-	-	-	-	GLINT	MS1	MS0

Bit 2 (GLINT): Global Interrupt enable/disable bit
0: Disable all interrupts
1: Enable all un-masked interrupts

■ **INTCON (R21h): Timer Interrupt Control Register**

Bit 7	Bit 6	Bit 5	Bit 4	Bit 3	Bit 2	Bit 1	Bit 0
-	-	-	-	-	TMR2IE	TMR1IE	TMR0IE

Bit 2 (TMR2IE): Control bit of Timer 2 interrupt
0: Disable Interrupt function
1: Enable Interrupt function

■ **INTSTA (R22h): Timer Interrupt Status Register**

Bit 7	Bit 6	Bit 5	Bit 4	Bit 3	Bit 2	Bit 1	Bit 0
-	-	-	-	-	TMR2I	TMR1I	TMR0I

Bit 2 (TMR2I): When Timer 2 interrupt occurs, this bit will be set, and cleared to "0" by software.

● **Code Example:**

```

; === Timer 2 interrupt
TIMERINT:
    PUSH
    JBC    INTSTA,TMR2I,Q_Time
    BC    INTSTA,TMR2I
    BTG    Port A,5
Q_Time:
    POP
    RETI
; === Timer2 = (1/32.768K) X [4 x (FFh + 1)]
Timer2SR:
    :
    ; PA.5 setting output pin
    :
    MOV    A,#0000010B
    MOV    TR2CON,A                ; Fosc & Pre-scale=1:4
    MOV    A,#0XFF
    MOV    TRL2,A                  ; 31.25ms=[4x(255+1)]/32768
    BS    TR2CON,T2EN              ; Timer 2 Enable
    BS    INTCON,TMR2IE            ; Timer 2 Interrupt Enable
    BC    INTSTA,TMR2I            ; Clear Timer 2 Interrupt Status
TMR2Loop:
    SJMP  TMR2Loop

```

8.4 Watchdog Timer (WDT)

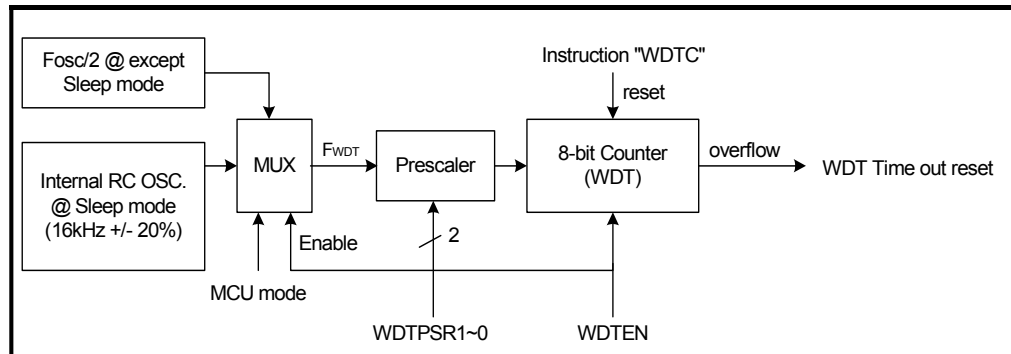

Figure 8-4 Watchdog Timer Functional Block Diagram

The watchdog timer (WDT) clock source comes from an on-chip RC oscillator (16kHz ± 20% MCU in Sleep mode) or FOSC/2 (MCU in Fast, Slow, or Idle mode). Therefore the WDT will keep on running even after the oscillator has been turned off.

The WDTEN bit controls the WDT's enable/disable functions. The initial state of the WDT is disabled. When WDT is enabled, its time-out will cause the MCU to reset. The "WDTC" instruction should be used to clear the WDT value before WDT time-out. A prescaler is provided to generate different clock rates for the WDT clock source. The prescaler ratio is defined by WDTPSR1 and WDTPSR0.

The WDT time out range is 64ms (prescaler=1:4) to 2.048 second (prescaler=1:128).

$$T = \frac{1}{F_{WDT}} \times \text{Prescaler} \times (\text{WDT} + 1)$$

8.4.1 Watchdog Timer (WDT) Registers

■ TR2WCON (R27h): Timer 2/Watchdog Timer Control Register

Bit 7	Bit 6	Bit 5	Bit 4	Bit 3	Bit 2	Bit 1	Bit 0
WDTEN	–	WDTPSR1	WDTPSR0	T2EN	T2CS	T2PSR1	T2PSR0

Bit 7 (WDTEN): Watchdog Timer enable bit

0: Disable watchdog timer (stop running)

1: Enable watchdog timer

Bit 5 ~ Bit 4 (WDTPSR1 ~ WDTPSR0): Watchdog timer prescaler select bits

WDTPSR1: WDTPSR0	Prescaler Value
00	1:4
01	1:16
10	1:64
11	1:128

● **Code Example:**

```

; === WDT setting 2.048sec
:
; Set Timer1 0.5sec wakeup
:
BS    TR2WCON,WDTPSR1
BS    TR2WCON,WDTPSR0           ; Pre-scale 1:128
BS    TR2WCON,WDTEN
BC    CPUCON,MS1                ; Change to sleep mode
WDTC
SLEP
WDT_Loop:
    SJMP    WDT_Loop
; === Timer 1 interrupt 0.5 sec
TIMERINT:
    PUSH
    JBC    INTSTA,TMR1I,Q_Time
    BC    INTSTA,TMR1I
    WDTC
    :
    :
Q_Time:
    POP
    RETI

```

8.5 Input/Output Key

- Four pins key input (Port A.3 ~ 0) and 16 pins key strobe (shared with LCD segment) can have a maximum of 64 keys matrix.
- Automatic key scan or software key scan
- Interrupt is available under automatic key scan mode (SCAN=1)
- Wake-up is available when key input falling edge is detected under automatic key scan mode (SCAN=1).

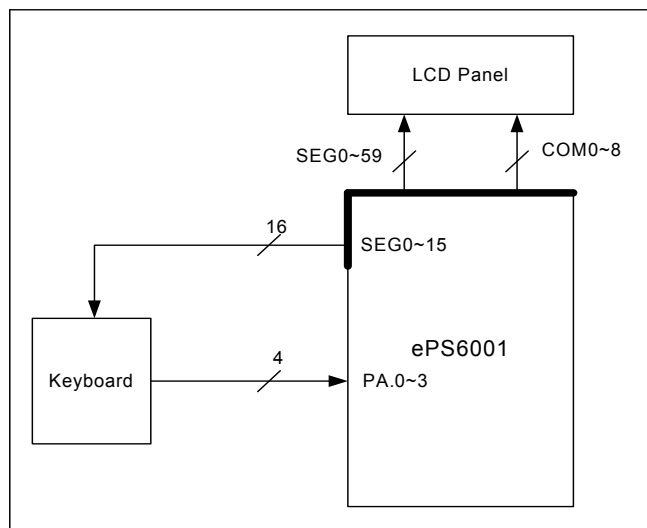

Figure 8-5a Key Function Block Diagram

As shown in the circuit diagram below, it is assumed that the key strobe output has resistance R_{ON} , while each key has resistance K_{ON} and capacitance C . Long strobe output duration will cause the LCD display to malfunction. Hence, strobe output time should be made as short as possible. Therefore, R_{IN} (pull-up resistance) should be low enough to allow quick charge to capacitor. On the contrary, R_{IN} should be high enough for V_{IN} to be considered as “L” level ($R_{IN} \gg R_{ON} + K_{ON}$). Thus, the value of R_{IN} should remain changeable.

The following is the normal key input process:

1. Output the strobe signal
2. Pull up the input port by lowest resistance (both R_1 and R_2 enabled). Capacitance is charged quickly.
3. Pull up the input port by highest resistance (only R_2 is enabled)
4. Read the key
5. Disable the pulled-up resistance
6. Stop the strobe signal

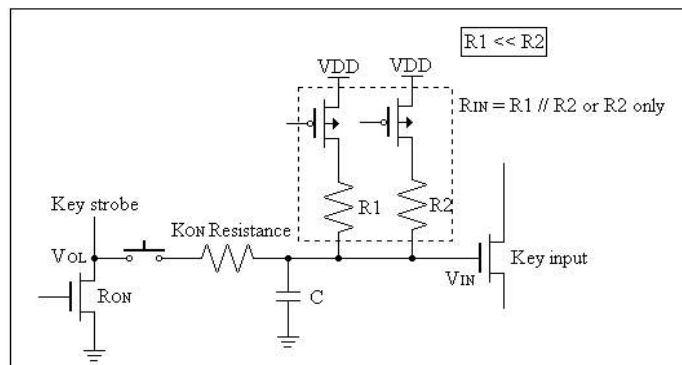

Figure 8-5b Key Circuit Diagram

8.5.1 Key Functions

SCAN	KE	R1EN	PA3PU ~ PA0PU	IEN ¹	Total Pull-up Resistor	Port A.0 ~ 3	Note
0	0	x	x	0	Floating	High-Z	-
	1	0	0	1	Floating	Floating	Prohibited
		0	1	1	R2	PA.0~.3	-
		1	0	1	R1	PA.0~.3	-
		1	1	1	$R1 // R2$ ²	PA.0~.3	-
1	x	0	0	0	Floating	High-Z	A ³
		1	1	0	$R1 // R2$ ²	High-Z	B ³
		0	1	1	R2	PA.0~ 3	C ³

x : Don't care

¹ Internal signal. Refer to the Automatic Key Scan Timing Diagram (Figure 8-7) below.

² $R1 // R2 = R1R2 / (R1+R2)$.

³ Sub clock signal. Refer to the Automatic Key Scan Timing Diagram (Figure 8-7) below.

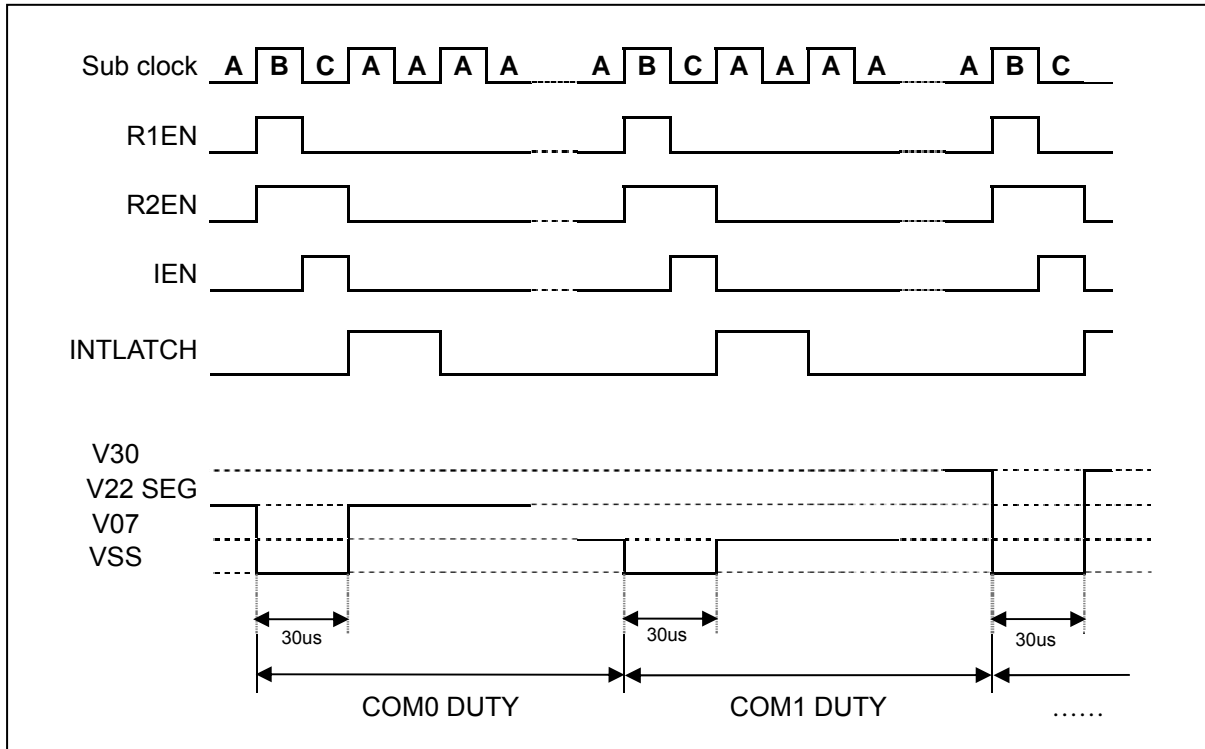

Figure 8-6 Automatic Key Scan Timing (SCAN = 1) Timing Diagram

8.5.2 Key Strobe

The key strobe pin shares with LCD segment pin in the CPU embedded with LCD driver model. When sharing with LCD segment, strobe output should be as short as possible to prevent LCD display error.

There are two ways to output a strobe signal, by Automatic Key scan and by software Key scan.

8.5.2.1 Automatic Key Scan

The LCD waveform has a 30 μ s low pulse at the beginning of every common duty signal by setting the SCAN bit of STBCON register. The strobe timing is as shown in the following figure (Figure 8-7) on Automatic Key Scan Strobe Signal.

When in automatic key scan mode, Bits 3 ~ 0 of PAINT or PAWAKE must be enabled. During key scan, Wake-up and interrupt will occur if any of the falling edge of the key input pins (Port A.3 ~ Port A.0) is detected.

NOTE

The "SCAN" bit turn on/off in the key loop should be avoided.

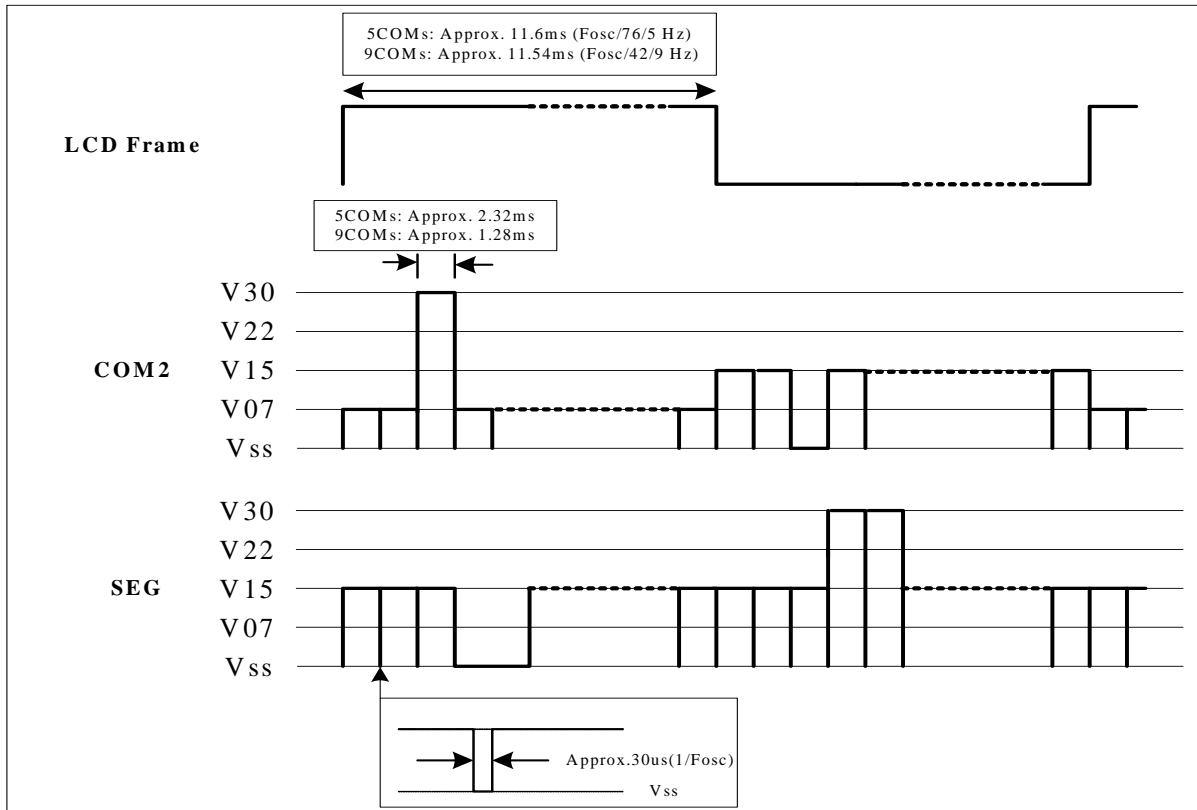

Figure 8-7 Automatic Key Scan Strobe Signal (SCAN = 1) Timing Diagram

8.5.2.2 Software Key Scan

Segment is switched to strobe signal temporarily by setting the BitST bit of the STBCON register to “1” and the SCAN bit to “0.” Set the STB3 ~ STB0 bits of the STBCON register to select which pin will be strobed.

■ In Idle Mode

During automatic key scanning, if any of the falling edge of the PA.0 ~ 3 pins is detected (when PAINTEN=1), Wake-up will occur. Then the CPU runs and interrupt is triggered (if enabled).

■ In Slow Mode or Fast Mode

Both automatic and software key scans are applicable.

- Automatic key scan is used to determine “whether any key is pressed.” If a key is pressed, PA.0 ~ 3 pin falling edge is detected, and then interrupt is triggered.
- Software key scan is used to determine “which key is pressed.”

8.5.2.3 Key Strobe Pin Function

STBCON			Key Strobe (Shared with Segments 0 ~ 15)															LCD			
SCAN	BitST	STB3~0	Seg 0	Seg 1	Seg 2	Seg 3	Seg 4	Seg 5	Seg 6	Seg 7	Seg 8	Seg 9	Seg 10	Seg 11	Seg 12	Seg 13	Seg 14	Seg 15	Seg 16:n-1	Com 0:m-1	
0	0	xxxx	Display waveform																		
	1	0000	0	1	1	1	1	1	1	1	1	1	1	1	1	1	1	1	1	Display waveform	
		0001	1	0	1	1	1	1	1	1	1	1	1	1	1	1	1	1	1		
		0010	1	1	0	1	1	1	1	1	1	1	1	1	1	1	1	1	1		
		0011	1	1	1	0	1	1	1	1	1	1	1	1	1	1	1	1	1		
		0100	1	1	1	1	0	1	1	1	1	1	1	1	1	1	1	1	1		
		0101	1	1	1	1	1	0	1	1	1	1	1	1	1	1	1	1	1		
		0110	1	1	1	1	1	1	0	1	1	1	1	1	1	1	1	1	1		
		0111	1	1	1	1	1	1	1	0	1	1	1	1	1	1	1	1	1		
		1000	1	1	1	1	1	1	1	1	0	1	1	1	1	1	1	1	1		
		1001	1	1	1	1	1	1	1	1	1	0	1	1	1	1	1	1	1		
		1010	1	1	1	1	1	1	1	1	1	1	0	1	1	1	1	1	1		
		1011	1	1	1	1	1	1	1	1	1	1	1	0	1	1	1	1	1		
		1100	1	1	1	1	1	1	1	1	1	1	1	1	0	1	1	1	1		
		1101	1	1	1	1	1	1	1	1	1	1	1	1	1	0	1	1	1		
1110	1	1	1	1	1	1	1	1	1	1	1	1	1	1	0	1	1				
1111	1	1	1	1	1	1	1	1	1	1	1	1	1	1	1	1	0				
1	x	xxxx	Display waveform with automatic key scan																		

8.5.3 Input/Output Key Registers

■ DCRA (R2Dh): Port A Direction Control Register

Bit 7	Bit 6	Bit 5	Bit 4	Bit 3	Bit 2	Bit 1	Bit 0
—	—	PA5DC	PA4DC	PA3DC	PA2DC	PA1DC	PA0DC

Bit 3 ~ Bit 0 (PA3DC ~ PA0DC): Direction control of PortA.0~3

- 0: Output pin
- 1: Input pin

■ PortA (R10h): Port A Register

Bit 3 ~ Bit 0: Port A input is selected by PA3DC~PA0DC bits of DCRA register (above)

The input structure and two-stage pull up resistor are controlled together by PA3PU ~ PA0PU bits of PACON register and R1EN, KE bits of STBCON register (see below and next page).

■ PACON (R29h): Port A Control Register

Bit 7	Bit 6	Bit 5	Bit 4	Bit 3	Bit 2	Bit 1	Bit 0
—	—	PA5PU	PA4PU	PA3PU	PA2PU	PA1PU	PA0PU

Bit3 ~ Bit0 (PA3PU ~ PA0PU): Pull-up resistor (R2 large resistor) control bits

- 0: Disable PortA.0 ~ PortA.3 pull-up resistor
- 1: Enable PortA.0 ~ PortA.3 pull-up resistor

■ **PAINTEN (R2Bh): Port A Interrupt Enable Control Register**

Bit 7	Bit 6	Bit 5	Bit 4	Bit 3	Bit 2	Bit 1	Bit 0
–	–	PA5IE	PA4IE	PA3IE	PA2IE	PA1IE	PA0IE

Bit 3 ~ Bit 0 (PA3IE ~ PA0IE): Interrupt control bit

0: Disable Interrupt function

1: Enable Interrupt function

NOTE

This function is only available with Port A selected as input pin.

■ **PAINTSTA (R2Ch): Port A Interrupt Status Register**

Bit 7	Bit 6	Bit 5	Bit 4	Bit 3	Bit 2	Bit 1	Bit 0
–	–	PA5I	PA4I	PA3I	PA2I	PA1I	PA0I

Bit 3 ~ Bit 0 (PA3I ~ PA0I): INT status of Port A interrupt

Set to “1” when pin falling edge is detected

Clear (“0”) by software

■ **STBCON (R20h): Strobe Output Control Register**

Bit 7	Bit 6	Bit 5	Bit 4	Bit 3	Bit 2	Bit 1	Bit 0
SCAN	KE	R1EN	BitST	STB3	STB2	STB1	STB0

Bit 7 (SCAN): Automatic key scan or specify the scan signal bit by bit

0: Key scan specified as Bit STB3 ~ 0 defined

1: Auto strobe scanning

Bit 6 (KE): Low nibble key input enable/disable control bit

0: Disable Low nibble key input function (Port A.0~3 do NOT correspond with Key input in software scan mode)

1: Enable Low nibble key input function (Port A.0~3 corresponds with Key input in software scan mode)

Bit 5 (R1EN): R1 pull-up resistor (small resistor) control bit for Port A.3 ~ Port A.0

0: Disable R1 pull-up resistor

1: Enable R1 pull-up resistor

Bit 4 (BitST): Enable bit strobe

0: Display waveform

1: Strobe signal specified as STB3 ~ 0 defined.

Bit 3 ~ Bit 0 (STB0 ~ STB3): Strobe output selector bits

● **Code Example:**

```

; Key Matrix 1 (Port A and Ground):
; === Sleep mode
PAIN_SR:
:
; --- Port A 0~5 input pins
MOV    A,#0X3F
MOV    DCRA,A
; --- Port A wakeup
MOV    A,#0X3F
MOV    PAWAKE,A
; --- R1EN & R2EN Pull-up & KE enable
MOV    A,#0X3F
MOV    PACON,A
BS     STBCON,R1EN
BS     STBCON,KE
; --- Port A interrupt enable
MOV    A,#0X3F
MOV    PAINTEN,A
CLR    PAINTSTA
BS     CPUCON,GLINT
; --- Sleep MODE
BC     CPUCON,MS1
PAINloop:
SLEP
NOP
:
SJMP  PAINloop
:
; *** Interrupt PortA data
INPTINT:
PUSH
MOV    A,PAINTSTA
MOV    Key_No,A
CLR    PAINTSTA
POP
RETI

```

NOTE

The PA.0~3's code option must be set to "PA.0~3 and Port B / Port C or none" by setting the bit when the Key matrix combination is PA [3:0] and Port B / Port C or Ground.

```

; Key Matrix 2 (Port A.0~3 and SEG0 ~ SEG15):
; *** Key scan function
:
LCD display setting
:
MOV    A,#0X3F
OR     PACON,A           ; R2EN enable
MOV    PAWAKE,A         ; Port A setting wakeup function
:
; === Idle mode auto key scan routine
BS     STBCON,SCAN      ; Auto-key scan enable
BS     CPUCON,MS1      ; Idle mode
KeyIdle:
SLEP
NOP
:
; === Key scan routine
KeyScan:
CLR    STBCON           ; Auto-key scan disable
KeyLoop:
BS     STBCON,R1EN     ; R1EN enable
BS     STBCON,KE       ; Key enable
BS     STBCON,BitST    ; Strobe ON
LCALL  DLY50US
BC     STBCON,R1EN     ; R1EN disable
MOVL   A,Port A       ; Port A input data
BC     STBCON,BitST    ; Strobe OFF
BC     STBCON,KE       ; Key disable
JLE    A,#0X0E,KeyScan ; If A <= PORT A Goto KeyScan
INC    STBCON
:
SJMP   KeyLoop
:
KeyScan:
; --- Clear key number
CLR    Key_No
; --- Key Scan is finish
KeyScanOk:
MOV    Key_No,A
MOV    A,STBCON
MOVH   Key_No,A       ; Key_No: XXXX XXXX

```

NOTE

The PA.0~3 code option must be set to "PA.0~3 and SEG" by setting the bit when the Key matrix combination is PA [3:0] and SEG.

8.6 LCD Driver

The ePS6001 provides directly driven LCD. It supports multiplexed drive for 60SEGs × 9COMs which allows the use of pads as an LCD driver pin or as key input port. The available LCD RAM corresponds directly with LCD Pixel. The LCD frame rate is as follows.

Duty	LCD Frame Rate
1/5	Approx. 11.6ms ($F_{osc}/76/5$ Hz)
1/9	Approx. 11.54ms ($F_{osc}/42/9$ Hz)

This embedded LCD driver generates waveforms to drive the display.

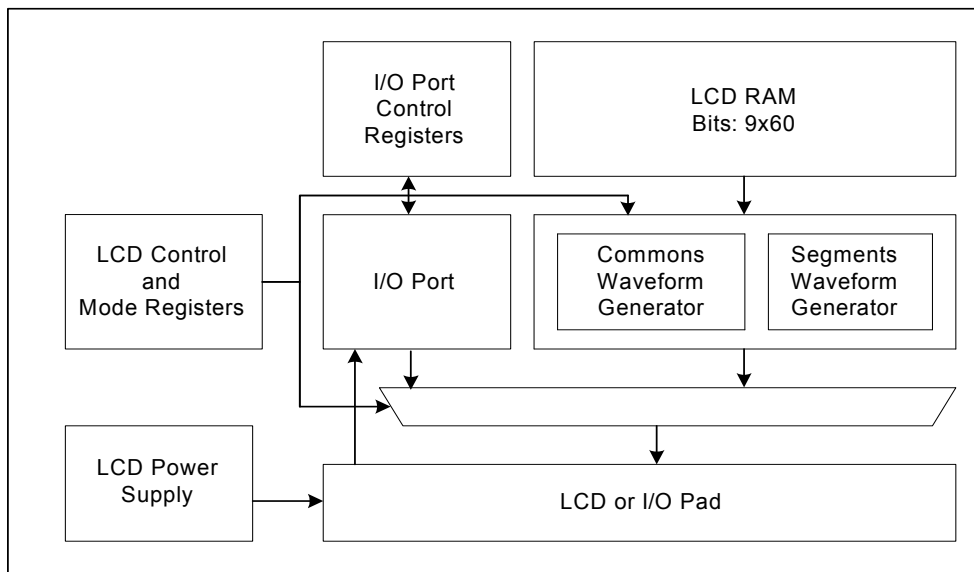
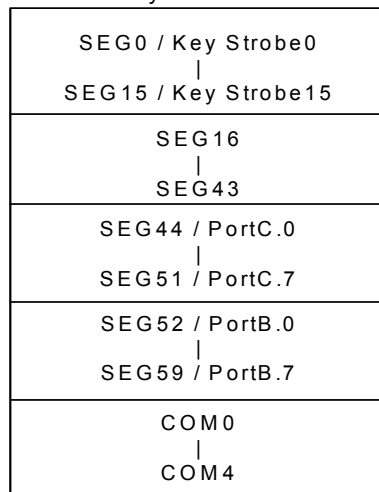

Figure 8-8a LCD Driver Function Block Diagram

a. 1/5 duty



b. 1/9 duty

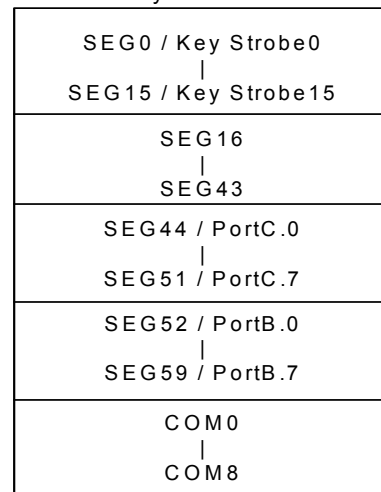

Figure 8-8b LCD Pin Configuration

8.6.1 LCD Driver Registers

■ LCDCON (R32h): LCD Control Register

Bit 7	Bit 6	Bit 5	Bit 4	Bit 3	Bit 2	Bit 1	Bit 0
–	BLANK	LCDCON	–	LCR1	LCR0	–	LBVON

Bit 6 (BLANK): LCD Blanking control bit

- 0: Disable
- 1: Enable (All SEG pins output “0” signal)

Bit 5 (LCDON): LCD display control bit

- 0: LCD display off
- 1: LCD display on

NOTE
All COM and SEG pins are tied to ground when LCD display is off.

Bit 3, Bit 2 (LCR1, LCR0): LCD Bias Voltage Charge-pump Rate select bits

LCR1:LCR0	Charge-Pump Rate (Hz)
00	8K
01	4K
10	2K
11	16K

Bit 0 (LBVON): Bias Voltage Charge-pump control bit

- 0: Disable
- 1: Enable

■ LCDARL (R09h): LCD RAM Column Address Register

Bit 7	Bit 6	Bit 5	Bit 4	Bit 3	Bit 2	Bit 1	Bit 0
LCDARL7	LCDARL6	LCDARL5	LCDARL4	LCDARL3	LCDARL2	LCDARL1	LCDARL0

See next Section 8.6.2; *LCD RAM Map* for details.

■ LCDDATA (R0Eh): LCDDATA register is an indirect address pointer of LCD RAM

Any instruction that uses LCDDATA as register, actually accesses LCD RAM via the address pointed by LCDARL (see figure below).

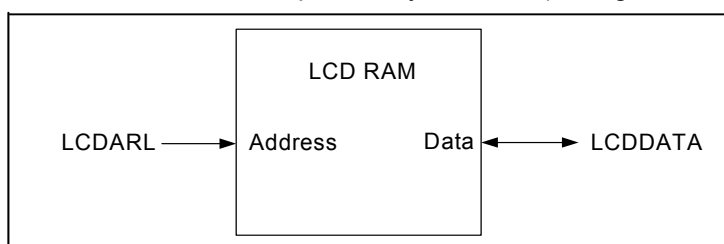

Figure 8-9 LCDDATA Register Access through LCD RAM

■ **POST_ID (R33h): Post Increase / Decrease Control Register**

Bit 7	Bit 6	Bit 5	Bit 4	Bit 3	Bit 2	Bit 1	Bit 0
–	LCD_ID	FSR1_ID	FSR0_ID	–	LCDPE	FSR1PE	FSR0PE

After accessing (read or write) the LCD RAM, the LCDARL register can be automatically increased or decreased by setting the POST_ID register.

Bit 6 (LCD_ID): Set to “1” to auto-increase the LCDARL register

Reset to “0” to auto-decrease the LCDARL register

Bit 2 (LCDPE): Enable LCDARL post increase/decrease function

● **Code Example:**

```

; === LCD Setting
L_Initial:
; --- LCD Off, Normal Display Mode, Charge-Pump rate=8K
    MOV    A,#0000001B
    MOV    LCDCON,A
    SCALL  DspRAMdot
; --- LCD turn-on
    BS     LCDCON,LCDON
    LCALL  Delay1sec
    :
DspLoop:
; --- LCD Blanking
    BS     LCDCON,BLANK
    LCALL  Delay1sec
; --- Normal display
    BC     LCDCOM,BLANK
    LCALL  Delay1sec
    :
    SJMP  DspLoop
; *** Display LCD RAM is data 55 & AA
DspRAMdot:
; --- LCD increase enable.
    BS     POST_ID,LCDPE
    BS     POST_ID,LCD_ID
DspRAMd1:
    CLR    LCDARL
    TBPTH  #0x40
; === Write LCD RAM is dot matrix
WrLRAMd:
    MOV    A,#0XAA
    MOV    LCDDATA,A
    MOV    A,#0X55
    MOV    LCDDATA,A
    JDNZ  TABPTRH, WrLRAMd
    CLR    LCDARL
    RET

```

8.6.2 LCD RAM Map

■ 1/5 Duty

RAM Address		COM0	COM1	COM2	COM3	COM4	-	-	-
LCDARL		Bit 0	Bit 1	Bit 2	Bit 3	Bit 4	Bit 5	Bit 6	Bit 7
SEG0	00H								
:	:								
SEG59	3BH								

■ 1/9 Duty

RAM Address		COM 0	COM 1	COM 2	COM 3	COM 4	COM 5	COM 6	COM 7
LCDARL		Bit 0	Bit 1	Bit 2	Bit 3	Bit 4	Bit 5	Bit 6	Bit 7
SEG0	00H								
:	:								
SEG59	3BH								

RAM Address		COM 8	-	-	-	-	-	-	-
LCDARL		Bit 0	Bit 1	Bit 2	Bit 3	Bit 4	Bit 5	Bit 6	Bit 7
SEG0	40H								
:	:								
SEG59	7BH								

8.6.3 LCD Driving Method Circuit

■ 1/4 Bias

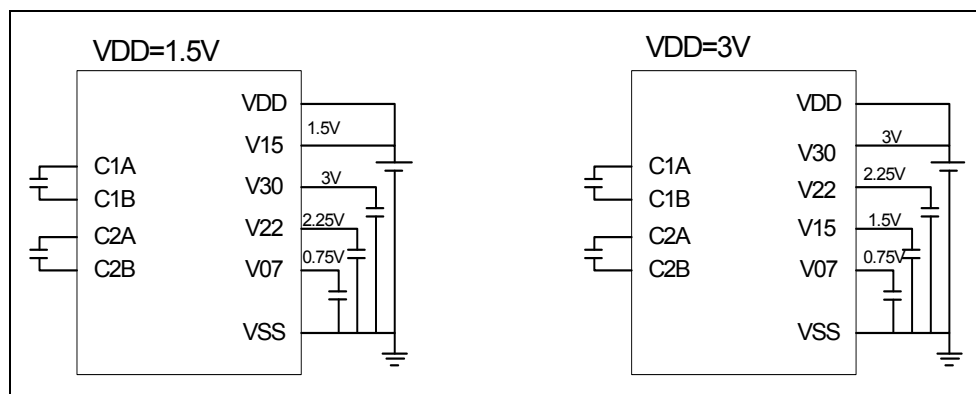

Figure 8-10 LCD Driving Method Circuit

8.6.4 LCD COM Waveforms

■ 1/5 Duty and 1/4 Bias

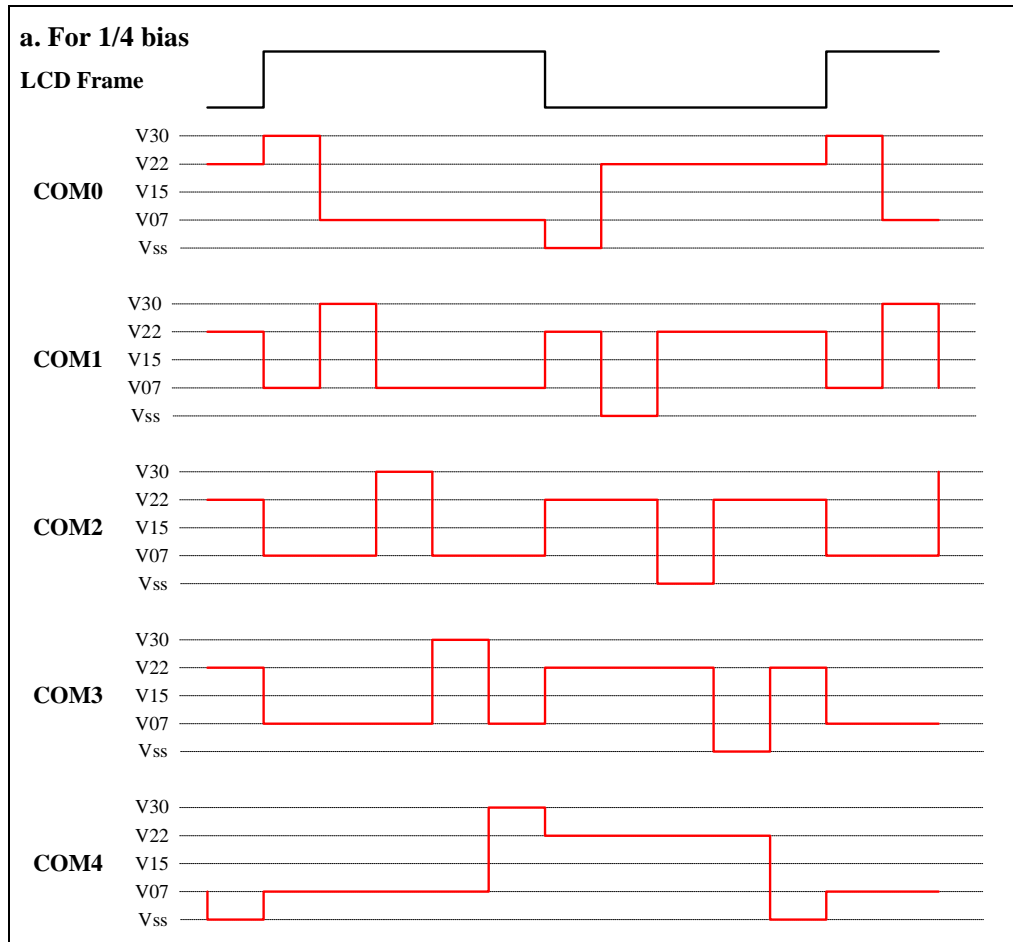

Figure 8-11a LCD COM Waveform for 1/5 Duty and 1/4 Bias

■ 1/9 Duty and 1/4 Bias

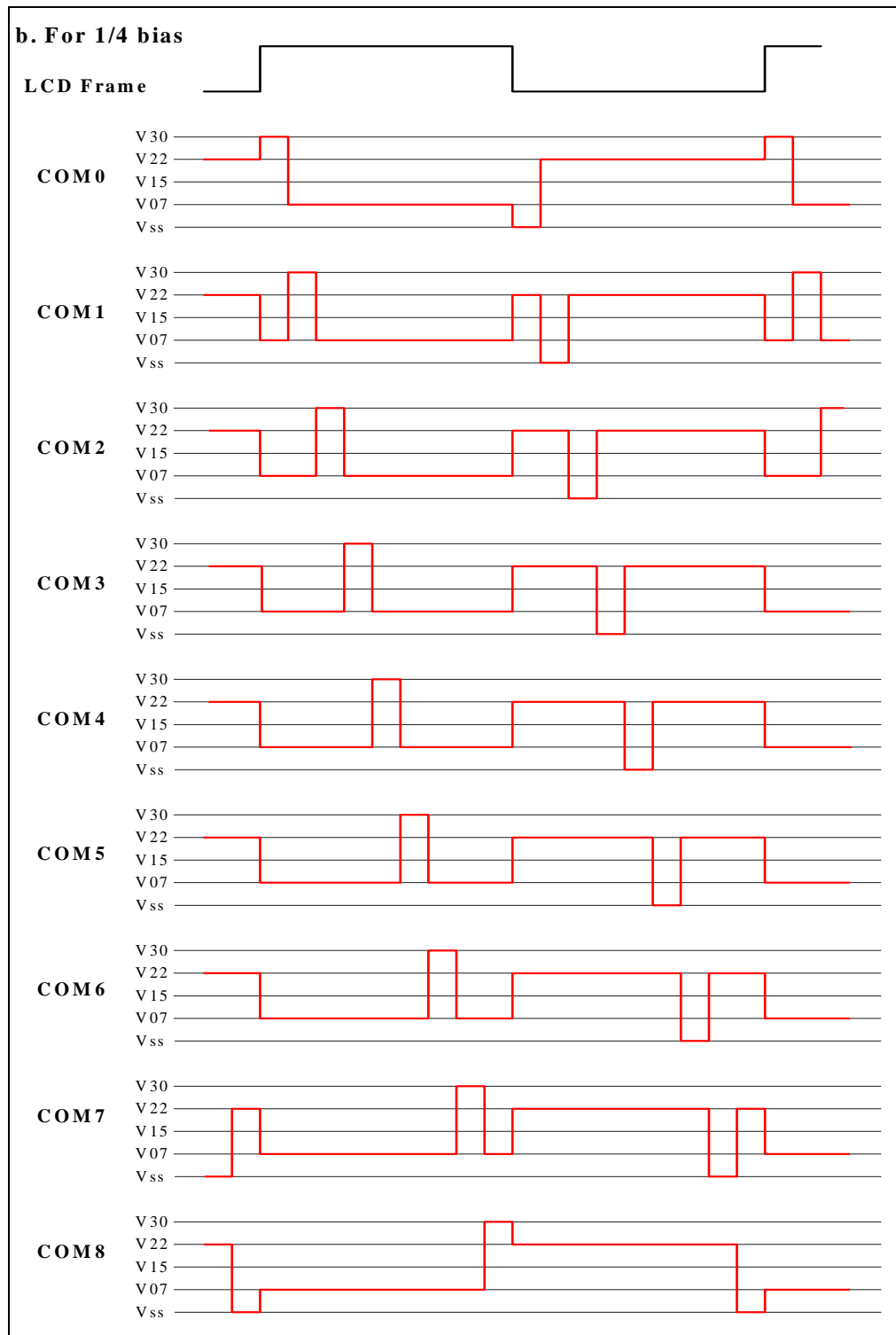

Figure 8-11b LCD COM Waveform for 1/9 Duty and 1/4 Bias

8.6.5 LCD COM and SEG Waveforms

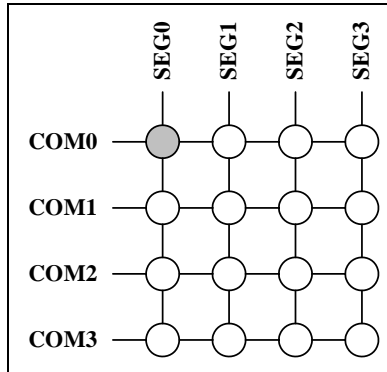

Figure 8-12a LCD COM and SEG Waveform Matrix

■ 1/5 or 1/9 Duty and 1/4 Bias

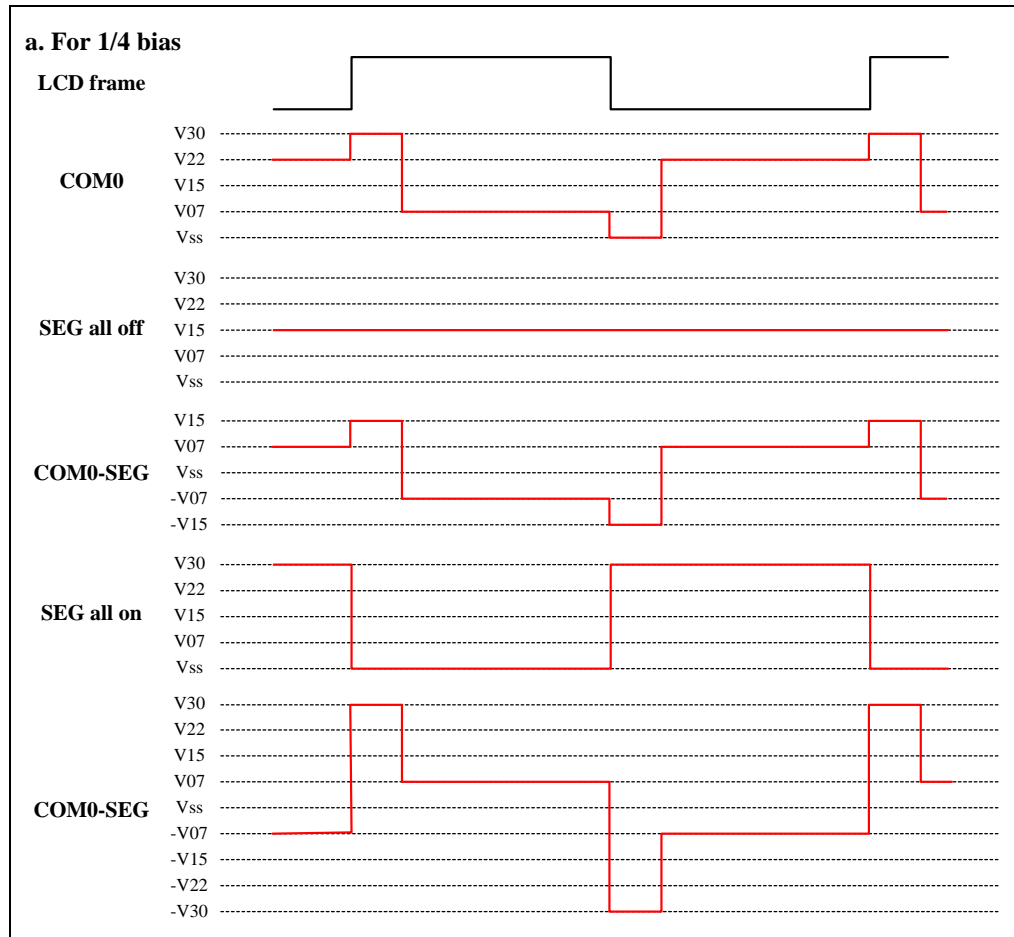

Figure 8-12b LCD COM and SEG Waveform for 1/5 or 1/9 Duty and 1/4 Bias

9 Electrical Characteristics

9.1 VDD=1.5V Electrical Characteristics

■ Absolute Maximum Ratings

Items	Sym.	Condition	Limits	Unit
Supply voltage	VDD	-	-0.3 to +1.8	V
Input voltage (general input port)	VIN	-	-0.5 to VDD +0.5	V
Operating temperature range	TOPR	-	-10 to +70	°C
Storage temperature range	TSTR	-	-55 to +125	°C

■ Recommended Operating Conditions

Items	Sym.	Condition	Limits	Unit
Supply voltage	VDD	-	1.2 to 1.8	V
Input voltage	VIH	-	VDD x 0.9 to VDD	V
	VIL	-	0 to VDD x 0.1	V
Operating temperature	TOPR	-	-10 to +70	°C

■ DC Electrical Characteristics (Condition: Ta=25°C, VDD= 1.5V)

Parameter	Sym.	Condition	Min	Typ	Max	Unit	
Clock	F _{HOSC}	Main-clock frequency	RC OSC. R=2MΩ	140	200	260	kHz
			RC OSC. R=1.2MΩ	210	300	390	
			RC OSC. R=680KΩ	350	500	650	
	F _{osc}	Sub-clock frequency	Internal RC OSC	24.6	32.8	41	kHz
Supply Current	I _{dd1}	Sleep mode	VDD=1.5V, no load	-	-	1	μA
	I _{dd2}	Idle mode	VDD=1.5V RC OSC, LCD enable, no load	-	2	4	
	I _{dd3}	Slow mode	VDD=1.5V, RC OSC, LCD enable, no load	-	4	6	
	I _{dd4}	Fast mode	VDD=1.5V, FHOSC =200KHz, LCD enable, no load	-	16	22	
	I _{dd5}		VDD=1.5V, FHOSC =300KHz, LCD enable, no load	-	22	32	
	I _{dd6}		VDD=1.5V, FHOSC =500KHz, LCD enable, no load	-	32	52	
Input Voltage	VIH1	PA [0:5], PB [0:7], PC[0:7] (as general input port)	0.7xVDD	-	VDD	V	
	VIL1		0	-	0.3xVDD		
Input Threshold Voltage (Schmitt)	VT+	RSTB	0.5xVDD	-	0.75xVDD	V	
	VT-		0.2xVDD	-	0.4xVDD		
Input Leakage Current	IIL	ALL Input port (without pull up/down resistor) Vin= VDD or GND	-	-	+/-1	μA	

(Continuation)

Parameter	Sym.	Condition	Min.	Typ.	Max.	Unit	
Large Pull-up Resistance	RPU5	RSTB Vin=GND	400	640	1000	K Ω	
Small Pull-up Resistance	RPU6	RSTB Vin=1V	12	40	80	K Ω	
Large Pull-down Resistance	RPD1	TEST Vin=VDD	250	500	800	K Ω	
Small Pull-down Resistance	RPD2	TEST Vin=0.5V	3	6	12	K Ω	
Output Current	IOH1	PA[0:5], PB[0:7], PC[0:7] (as general output port)	VDD=1.5V, VOH=1.2V, LCD enabled	-0.7	-0.9	-1.3	mA
	IOL1		VDD=1.5V, VOL=0.2V, LCD enabled	0.7	0.9	1.3	
Large Pull-up Resistance	RPU1	PA[0:5]	Key high resistance, pulled up by R2, LCD enabled, Vin2=0.5V		180	280	K Ω
	RPU3	PB[0:7], PC[0:7]	Vin=0.5V, LCD enabled		200	320	
Small Pull-up Resistance	RPU2	PA[0:3]	Key high resistance, pulled up by R2//R1, LCD enabled, Vin2=0 V		12	18	K Ω
	RPU4	PA[4:5]	Vin=1V, LCD enabled		40	60	
Data retention voltage	Vret		1.0	-	-	V	
Power on reset voltage	Vpor		1.0	1.05	1.1		
LCD Driver							
LCD Display Output ON-resistance	ROC	Com[0:8]	VOH=V30 +/- 0.2V	0.35	0.4	0.5	K Ω
			VOM=V22 +/- 0.2V	0.55	0.65	0.75	
			VOM=V07 +/- 0.2V	0.35	0.40	0.45	
			VOL=0.2V	0.25	0.3	0.35	
	ROS	Seg[0:59]	VOH=V30 +/- 0.2V	0.35	0.4	0.5	K Ω
			VOM=V15 +/- 0.2V	0.45	0.6	0.85	
VOL=0.2V			0.25	0.3	0.35		
Strobe Output ON-resistance	ROP	Seg[0:15]	V=VDD-0.2V	145	200	280	K Ω
	RON	(as key strobe)	V=0.2V	1	1.2	1.5	

9.2 VDD=3.0V Electrical Characteristics

■ Absolute Maximum Ratings

Items	Sym.	Condition	Limits	Unit
Supply voltage	VDD		-0.3 to +3.6	V
Input voltage (general input port)	VIN		-0.5 to VDD +0.5	V
Operating temperature range	TOPR		-10 to +70	°C
Storage temperature range	TSTR		-55 to +125	°C

■ Recommended Operating Conditions

Items	Sym.	Condition	Limits	Unit
Supply voltage	VDD		2.4 to 3.6	V
Input voltage	VIH		VDD x 0.9 to VDD	V
	VIL		0 to VDD x 0.1	V
Operating temperature	TOPR		-10 to +70	°C

■ DC Electrical Characteristics (Condition: Ta=25 °C, VDD= 3.0V)

Parameter	Sym.	Condition		Min	Typ	Max	Unit	
CLOCK	F _{HOSC}	Main-clock frequency	RC OSC., R=2MΩ	140	200	260	KHz	
			RC OSC., R=1.2MΩ	210	300	390		
			RC OSC., R=750kΩ	350	500	650		
			RC OSC., R=330KΩ	0.8	1	1.2	MHz	
			RC OSC., R=240kΩ	1.2	1.5	1.8		
			RC OSC., R=180kΩ	1.6	2	2.4		
	F _{OSC}	Sub-clock frequency	Internal RC OSC.	24.6	32.8	41	KHz	
Supply Current	I _{dd1}	SLEEP mode	VDD=3V, no load	-	-	-	μA	
	I _{dd2}	IDLE mode	VDD=3V RC OSC, LCD enabled, no load	-	8	12		
	I _{dd3}	SLOW mode	VDD=3V, RC OSC, LCD disabled, no load	-	10	14		
	I _{dd4}	FAST mode	no load	VDD=3V, F _{HOSC} =200KHz, LCD enabled,	-	40		50
	I _{dd5}			VDD=3V, F _{HOSC} =300KHz, LCD enabled,	-	60		70
	I _{dd6}			VDD=3V, F _{HOSC} =500KHz, LCD enabled,	-	90		110
	I _{dd7}			VDD=3V, FHOSC =1MHz, LCD enable,	-	140		170
	I _{dd8}			VDD=3V, FHOSC =1.5MHz, LCD enable,	-	210		255
	I _{dd9}	VDD=3V, FHOSC =2MHz, LCD enable,	-	280	340			
Input Voltage	VIH1	PA[0:5] ,PB[0:7],PC[0:7] (as general input port)		VDD×0.7	-	VDD	V	
	VIL1			0	-	VDD×0.3		

(Continuation)

Parameter	Sym.	Condition		Min	Typ	Max	Unit
Input Threshold Voltage (Schmitt)	VT+	RSTB		0.5×VDD	-	0.75×VDD	V
	VT-			0.2×VDD	-	0.4×VDD	
Input Leakage Current	IIL	ALL Input port (without pull up/down resistor) Vin= VDD or GND		—	—	+/-1	μA
Output Current	IOH1	PA[0:5], PB[0:7], PC[0:7]	VDD=3V, VOH=2.7V	-1.8	-2.4	-3.2	mA
	IOL1	(as general output port)	VDD=3V, VOL=0.2V	1.6	2.0	2.3	
Large Pull-up Resistance	RPU1	PA[0:5]	Key high resistance, pulled-up by R2, LCD enabled, Vin2=0.5V	125	155	195	KΩ
	RPU3	PB[0:7], PC[0:7]	Vin=0.5V	70	85	105	
	RPU5	RSTB	Vin=GND	90	150	230	
Small Pull-up Resistance	RPU2	PA[0:3]	Key high resistance, pulled up by R2//R1, LCD enable, Vin2=0 V	3.5	4	5.5	KΩ
	RPU4	PA[4:5]	Vin=2V	65	80	100	
	RPU6	RSTB	Vin=2V	7	12	18	
Large Pull-down Resistance	RPD1	TEST	Vin=VDD	120	185	260	KΩ
Small Pull-down Resistance	RPD2	TEST	Vin=1V	2	3	5	KΩ
Data Retention Voltage	Vret			2.2	—	—	V
Power On Reset Voltage	Vpor			2.2	2.4	2.6	V
LCD Driver							
LCD Display Output ON-resistance	ROC	Com[0:8]	VOH=V30 +/- 0.1V	0.35	0.4	0.50	KΩ
			VOM=V22 +/- 0.1V	0.45	0.65	0.85	
			VOM=V07 +/- 0.1V	0.2	0.35	0.45	
			VOL=0.1V	0.2	0.27	0.35	
	ROS	Seg[0:59]	VOH=V30 +/- 0.1V	0.35	0.4	0.50	KΩ
			VOM=V15 +/- 0.1V	1.5	3	7	
VOL=0.1V			0.2	0.27	0.35		
Strobe Output ON-resistance	ROP	Seg[0:15] (as key strobe)	V=VDD-0.2V	50	60	75	KΩ
	RON		V=0.2V	0.5	0.7	0.85	

10 Pin Type Circuit Diagrams

■ Reset Pin Type

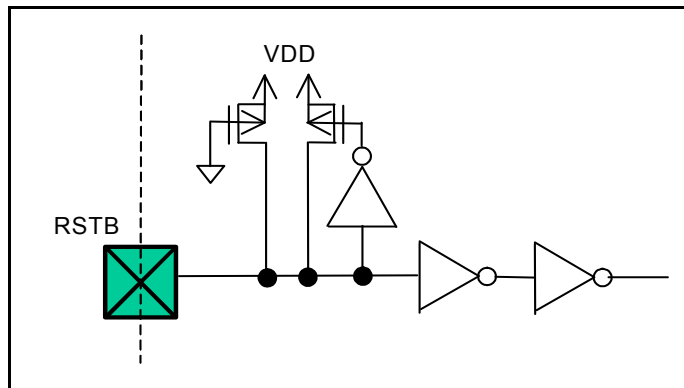

Figure 10-1a Reset Pin Type Circuit Diagram

■ Test Pin Type

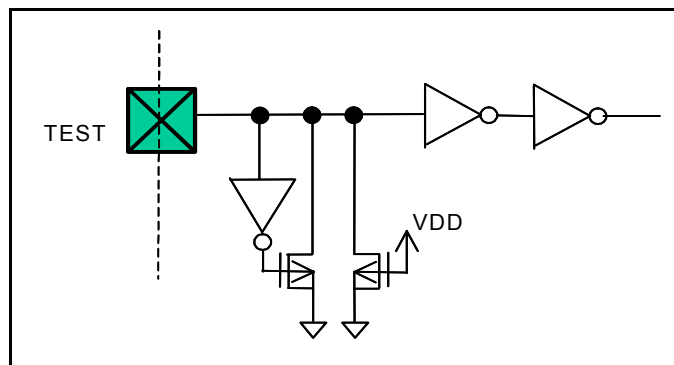

Figure 10-1b Test Pin Type Circuit Diagram

■ Oscillator Pin Type

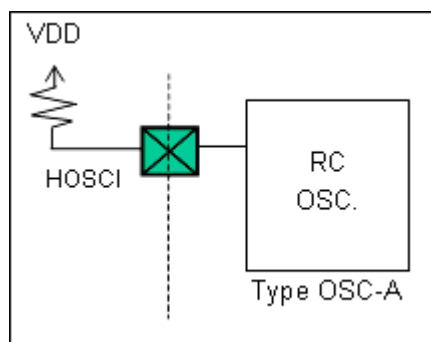

Figure 10-1c Oscillator Pin Type Circuit Diagram

■ Input Pin Type (PA.0~5)

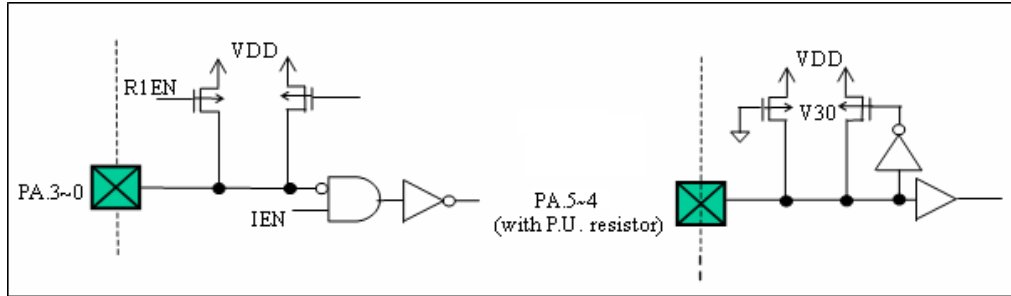

Figure 10-1d Input Pin Type Circuit Diagram

■ SEG and I/O Share Pin Type

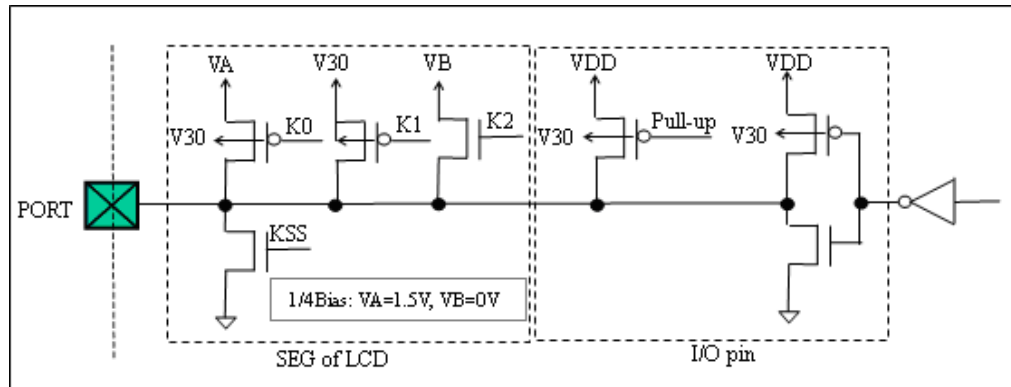

Figure 10-1e SEG and I/O Share Pin Type Circuit Diagram

■ General SEG and COM Pin Type

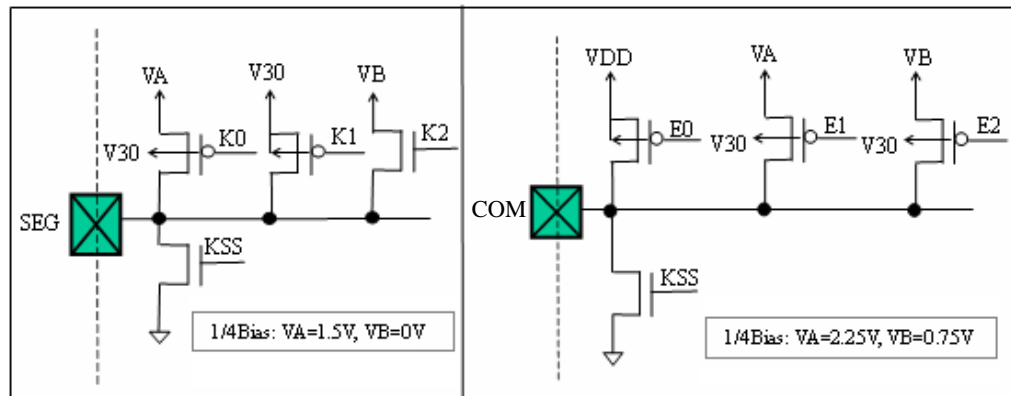

Figure 10-1f General SEG and COM Share Pin Type Circuit Diagram

11 Application Circuits

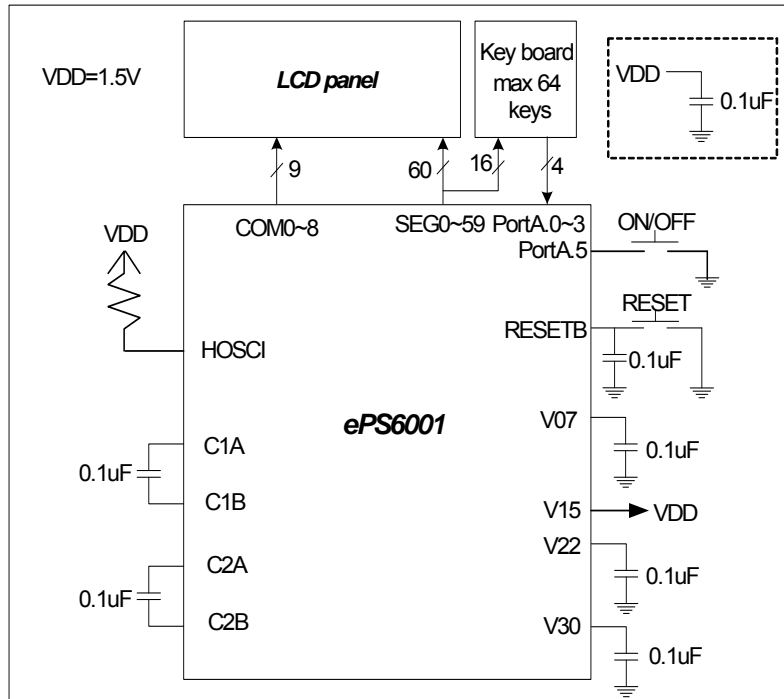

Figure 11-1a VDD=1.5V Application Circuit Diagram

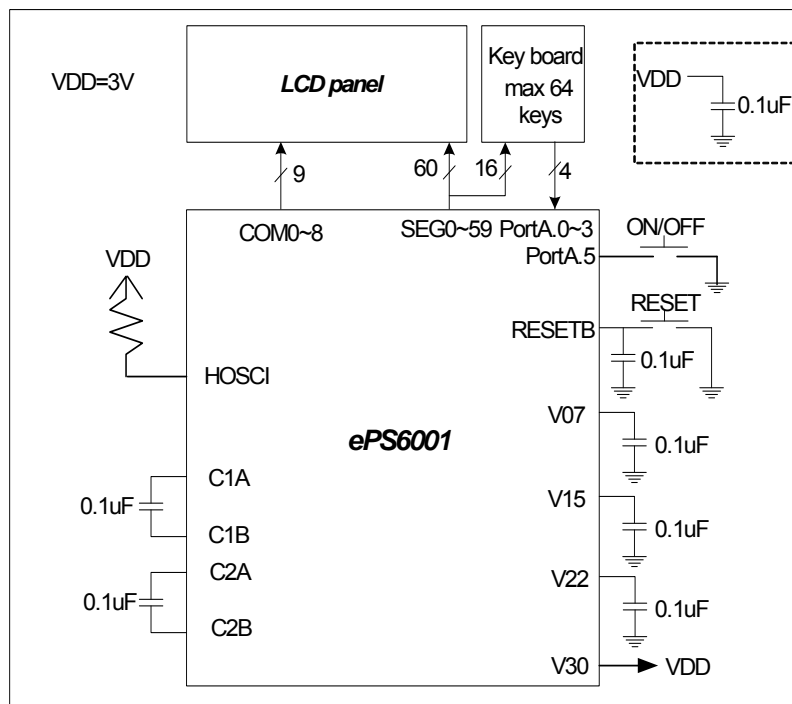

Figure 11-1b VDD=3V Application Circuit Diagram

12 Instruction Set

Legend: **addr:** address **k:** constant **p:** special file register (0h~1Fh)
b: bit **i:** Table pointer control **r:** File Register

Type	Binary Instruction	Mnemonic	Operation	Status Affected	Cycle
System Control	0000 0000 0000 0000	NOP	No operation	None	1
	0000 0000 0000 0001	WDTC	WDT ← 0; /TO ← 1; /PD ← 1	None	1
	0000 0000 0000 0010	SLEP	Enter IDLE MODE if MS1=1 Enter SLEEP MODE if MS1=0	None	1
	0010 0111 rrrr rrrr	RPT r ("r" is the content of register r)	Single repeat (r) times on next instruction	None	1
	0100 0011 kkkk kkkk	BANK #k	BSR ← k	None	1
Subroutine	0011 aaaa aaaa aaaa	S0CALL addr	Top of Stack] ← PC+1 PC[11:0] ← addr PC[12:16] ← 00000 ¹	None	1
	111a aaaa aaaa aaaa	SCALL addr	[Top of Stack] ← PC+1; PC[12:0] ← addr; PC[13:16] unchanged	None	1
	0000 0000 0011 0000 00aa aaaa aaaa aaaa	LCALL addr (two words)	[Top of Stack] ← PC+1; PC ← addr	None	2
	0010 1011 1111 1110	RET	PC ← (Top of Stack)	None	1
	0010 1011 1111 1111	RETI	PC ← (Top of Stack); Enable Interrupt	None	1
Compare	0010 0101 rrrr rrrr	TEST r	Z ← 0 if r <> 0; Z ← 1 if r=0	Z	1
Jump	110a aaaa aaaa aaaa	SJMP addr	PC ← addr PC[13..15] unchange	None	1
	0000 0000 0010 0000 00aa aaaa aaaa aaaa	LJMP addr (two words)	PC ← addr	None	2
Compare & Jump	0101 0000 rrrr rrrr aaaa aaaa aaaa aaaa	JDNZ A,r,addr	A ← r-1, jump to addr if not zero PC[15:0] ← addr ²	None	2
	0101 0001 rrrr rrrr aaaa aaaa aaaa aaaa	JDNZ r,addr	r ← r-1, jump to addr if not zero PC[15:0] ← addr ²	None	2
	0100 0111 kkkk kkkk aaaa aaaa aaaa aaaa	JGE A,#k,addr	Jump to addr if A ≥ k PC[15:0] ← addr ²	None	2
	0100 1000 kkkk kkkk aaaa aaaa aaaa aaaa	JLE A,#k,addr	Jump to addr if A ≤ k PC[15:0] ← addr ²	None	2
	0100 1001 kkkk kkkk aaaa aaaa aaaa aaaa	JE A,#k,addr	Jump to addr if A=k PC[15:0] ← addr ²	None	2
	0101 0101 rrrr rrrr aaaa aaaa aaaa aaaa	JGE A,r,addr	Jump to addr if A ≥ r PC[15:0] ← addr ²	None	2
	0101 0110 rrrr rrrr aaaa aaaa aaaa aaaa	JLE A,r,addr	Jump to addr if A ≤ r PC[15:0] ← addr ²	None	2
	0101 0111 rrrr rrrr aaaa aaaa aaaa aaaa	JE A,r,addr	Jump to addr if A=r PC[15:0] ← addr ²	None	2

(Continuation)

Type	Binary Instruction	Mnemonic	Operation	Status Affected	Cycle
Bit Compare and Jump	0101 1bbb rrrr rrrr aaaa aaaa aaaa aaaa	JBC r,b,addr	If r(b)=0,jump to addr PC[15:0] ← addr ²	None	2
	0110 0bbb rrrr rrrr aaaa aaaa aaaa aaaa	JBS r,b,addr	If r(b)=1,jump to addr PC[15:0] ← addr ²	None	2
Data Transfer	0010 0000 rrrr rrrr	MOV A,r	$A \leftarrow r$	Z	1
	0010 0001 rrrr rrrr	MOV r,A	$r \leftarrow A$	None	1
	100p pppp rrrr rrrr	MOV RP p,r	Register p ← Register r	None	1
	101p pppp rrrr rrrr	MOV PR r,p	Register r ← Register p	None	1
	0100 1110 kkkk kkkk	MOV A,#k	$A \leftarrow k$	None	1
	0010 0100 rrrr rrrr	CLR r	$r \leftarrow 0$	Z	1
ROM Table Look-up	0100 0000 kkkk kkkk	TBPTL #k	TABPTRL ← k	None	1
	0100 0001 kkkk kkkk	TBPTM #k	TABPTRM ← k	None	1
	0100 0010 kkkk kkkk	TBPTH #k	TABPTRH ← k	None	1
	0010 11ii rrrr rrrr	TBRD i,r	$r \leftarrow \text{ROM}[(\text{TABPTR})]$ ^{3, 4}	None	2
	0010 1111 rrrr rrrr	TBRD A,r	$r \leftarrow \text{ROM}[(\text{TABPTR}+\text{ACC})]$ ⁴	None	2
Logic Operation	0000 0010 rrrr rrrr	OR A,r	$A \leftarrow A .\text{or. } r$	Z	1
	0000 0011 rrrr rrrr	OR r,A	$r \leftarrow r .\text{or. } A$	Z	1
	0100 0100 kkkk kkkk	OR A,#k	$A \leftarrow A .\text{or. } k$	Z	1
	0000 0100 rrrr rrrr	AND A,r	$A \leftarrow A .\text{and. } r$	Z	1
	0000 0101 rrrr rrrr	AND r,A	$r \leftarrow r .\text{and. } A$	Z	1
	0100 0101 kkkk kkkk	AND A,#k	$A \leftarrow A .\text{and. } k$	Z	1
	0000 0110 rrrr rrrr	XOR A,r	$A \leftarrow A .\text{xor. } r$	Z	1
	0000 0111 rrrr rrrr	XOR r,A	$r \leftarrow r .\text{xor. } A$	Z	1
	0100 0110 kkkk kkkk	XOR A,#k	$A \leftarrow A .\text{xor. } k$	Z	1
	0000 1000 rrrr rrrr	COMA r	$A \leftarrow /r$	Z	1
	0000 1001 rrrr rrrr	COM r	$r \leftarrow /r$	Z	1
Arithmetic Operation	0001 1100 rrrr rrrr	INCA r	$A \leftarrow r+1$	C, Z	1
	0001 1101 rrrr rrrr	INC r	$r \leftarrow r+1$	C, Z	1
	0001 0000 rrrr rrrr	ADD A,r	$A \leftarrow A+r$	C,DC,Z,OV,SGE,SLE	1
	0001 0001 rrrr rrrr	ADD r,A	$r \leftarrow r+A$ ⁵	C,DC,Z,OV,SGE,SLE	1
	0100 1010 kkkk kkkk	ADD A,#k	$A \leftarrow A+k$	C,DC,Z,OV,SGE,SLE	1
	0001 0010 rrrr rrrr	ADC A,r	$A \leftarrow A+r+C$	C,DC,Z,OV,SGE,SLE	1
	0001 0011 rrrr rrrr	ADC r,A	$r \leftarrow r+A+C$	C,DC,Z,OV,SGE,SLE	1
	0100 1011 kkkk kkkk	ADC A,#k	$A \leftarrow A+k+C$	C,DC,Z,OV,SGE,SLE	1
	0001 1110 rrrr rrrr	DECA r	$A \leftarrow r-1$	C,Z	1
	0001 1111 rrrr rrrr	DEC r	$r \leftarrow r-1$	C,Z	1
	0001 0110 rrrr rrrr	SUB A,r	$A \leftarrow r-A$ ⁶	C,DC,Z,OV,SGE,SLE	1
	0001 0111 rrrr rrrr	SUB r,A	$r \leftarrow r-A$ ⁶	C,DC,Z,OV,SGE,SLE	1
	0100 1100 kkkk kkkk	SUB A,#k	$A \leftarrow k-A$ ⁶	C,DC,Z,OV,SGE,SLE	1
	0001 1000 rrrr rrrr	SUBB A,r	$A \leftarrow r-A/-C$ ⁶	C,DC,Z,OV,SGE,SLE	1
	0001 1001 rrrr rrrr	SUBB r,A	$r \leftarrow r-A/-C$ ⁶	C,DC,Z,OV,SGE,SLE	1
	0100 1101 kkkk kkkk	SUBB A,#k	$A \leftarrow k-A/-C$ ⁶	C,DC,Z,OV,SGE,SLE	1
	0001 0100 rrrr rrrr	ADD DC A,r	$A \leftarrow (\text{Decimal ADD}) A+r+C$	C, DC, Z	1
	0001 0101 rrrr rrrr	ADD DC r,A	$r \leftarrow (\text{Decimal ADD}) r+A+C$	C, DC, Z	1
	0001 1010 rrrr rrrr	SUB DB A,r	$A \leftarrow (\text{Decimal SUB}) r-A/-C$	C, DC, Z	1
	0001 1011 rrrr rrrr	SUB DB r,A	$r \leftarrow (\text{Decimal SUB}) r-A/-C$	C, DC, Z	1

(Continuation)

Type	Binary Instruction	Mnemonic	Operation	Status Affected	Cycle
Rotate	0000 1010 rrrr rrrr	RRCA r	$A(n-1) \leftarrow r(n); C \leftarrow r(0); A(7) \leftarrow C$	C	1
	0000 1011 rrrr rrrr	RRC r	$r(n-1) \leftarrow r(n); C \leftarrow r(0); r(7) \leftarrow C$	C	1
	0000 1100 rrrr rrrr	RLCA r	$A(n+1) \leftarrow r(n); C \leftarrow r(7); A(0) \leftarrow C$	C	1
	0000 1101 rrrr rrrr	RLC r	$r(n+1) \leftarrow r(n); C \leftarrow r(7); r(0) \leftarrow C$	C	1
Shift	0010 0010 rrrr rrrr	SHRA r	$A(n-1) \leftarrow r(n); A(7) \leftarrow C$	None	1
	0010 0011 rrrr rrrr	SHLA r	$A(n+1) \leftarrow r(n); A(0) \leftarrow C$	None	1
Exchange	0101 0100 rrrr rrrr	EX r	$r(7-0) \leftrightarrow A(7-0)$	None	1
Bit Manipulation	0110 1bbb rrrr rrrr	BC r,b	$r(b) \leftarrow 0$	None	1
	0111 0bbb rrrr rrrr	BS r,b	$r(b) \leftarrow 1$	None	1
	0111 1bbb rrrr rrrr	BTG r,b	$r(b) \leftarrow \neg r(b)$	None	1
Nibble Operation	0101 0010 rrrr rrrr	EXL r	$r(3-0) \leftrightarrow A(3-0)$	None	1
	0101 0011 rrrr rrrr	EXH r	$r(7-4) \leftrightarrow A(3-0)$	None	1
	0010 0110 rrrr rrrr	MOVL r,A	$r(3-0) \leftarrow A(3-0)$	None	1
	0010 1000 rrrr rrrr	MOVH r,A	$r(7-4) \leftarrow A(3-0)$	None	1
	0010 1001 rrrr rrrr	MOVL A,r	$A(3-0) \leftarrow r(3-0); A(7-4) \leftarrow 0$	None	1
	0010 1010 rrrr rrrr	MOVH A,r	$A(3-0) \leftarrow r(7-4); A(7-4) \leftarrow 0$	None	1
	0000 0001 rrrr rrrr	SFR4 r	$r(7-4) \leftarrow A(3-0); r(3-0) \leftarrow r(7-4); A(3-0) \leftarrow r(3,0)$	None	1
	0100 1111 rrrr rrrr	SFL4 r	$r(3-0) \leftarrow A(3-0); r(7-4) \leftarrow r(3-0); A(3-0) \leftarrow r(7-4)$	None	1
	0000 1111 rrrr rrrr	SWAP r	$r(0:3) \leftrightarrow r(4:7)$	None	1
	0000 1110 rrrr rrrr	SWAPA r	$r(0:3) \rightarrow A(4:7); r(4:7) \rightarrow A(0:3)$	None	1

¹ *S0CALL* addressing ability is from 0x000 to 0xFFFF (4K words space).

² *The maximum jump range is 8K words absolute address.*

³ *TBRD i, r: $r \leftarrow ROM [(TABPTR)]$*

i=00: TABPTR no change

wi=01: $TABPTR \leftarrow TABPTR+1$

i=10: $TABPTR \leftarrow TABPTR-1$

⁴ *TABPTR = (TABPTRM: TABPTRL)*

Bit 0 = 0: Low byte of the pointed ROM data

Bit 0 = 1: High byte of the pointed ROM data

NOTE

- *Bit 0 of TABPTRL is used to select either low byte or high byte of the pointed ROM data.*
- *The maximum table look-up space is internal 48K bytes (24K words).*

⁵ *Carry bit of "ADD PCL, A" or "ADD TABPTRL, A" will automatically carry into PCM or TABPTRM. The Instruction cycle of write to PC (program counter) takes two cycles.*

⁶ *When in SUB operation, borrow flag is indicated by the inverse of the carry bit, that is B=/C*

13 Pad Diagram and Locations

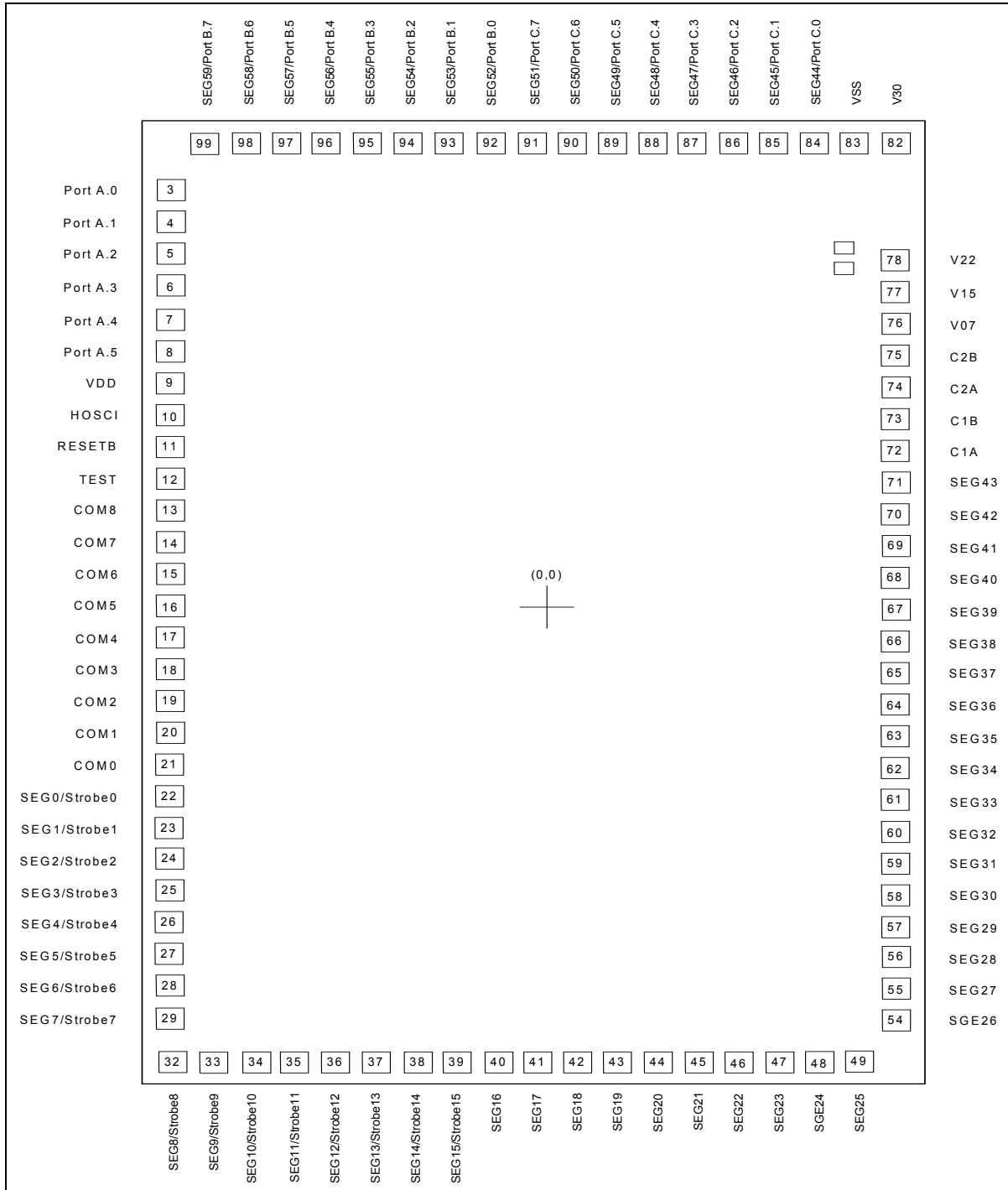

Figure 13-1 ePS6001 88 Pin-Out

13.1 Pad Coordinates

■ Chip Size: 1830 × 2820 μm²

Pin NO.	Symbol	X	Y	Pin NO.	Symbol	X	Y
1	NC	-	-	41	SEG17	-5.35	-1317.5
2	NC	-	-	42	SEG18	84.65	-1317.5
3	PortA.0	-832.5	1222.5	43	SEG19	174.65	-1317.5
4	PortA.1	-832.5	1127.5	44	SEG20	264.65	-1317.5
5	PortA.2	-832.5	1027.55	45	SEG21	354.65	-1317.5
6	PortA.3	-832.5	927.55	46	SEG22	444.65	-1317.5
7	PortA.4	-832.5	837.55	47	SEG23	534.65	-1317.5
8	PortA.5	-832.5	747.55	48	SEG24	624.65	-1317.5
9	VDD	-832.5	644.4	49	SEG25	714.65	-1317.5
10	HOSCI	-832.5	547.55	50	NC	-	-
11	RESETB	-822.5	429.65	51	NC	-	-
12	TEST	-822.5	339.65	52	NC	-	-
13	COM8	-822.5	249.65	53	NC	-	-
14	COM7	-822.5	159.65	54	SEG26	822.5	-1177.2
15	COM6	-822.5	69.65	55	SEG27	822.5	-1087.2
16	COM5	-822.5	-20.35	56	SEG28	822.5	-997.2
17	COM4	-822.5	-110.35	57	SEG29	822.5	-907.2
18	COM3	-822.5	-200.35	58	SEG30	822.5	-817.2
19	COM2	-822.5	-290.35	59	SEG31	822.5	-727.2
20	COM1	-822.5	-380.35	60	SEG32	822.5	-637.2
21	COM0	-822.5	-470.35	61	SEG33	822.5	-547.2
22	SEG0/Strobe0	-822.5	-560.35	62	SEG34	822.5	-457.2
23	SEG1/Strobe1	-822.5	-650.35	63	SEG35	822.5	-367.2
24	SEG2/Strobe2	-822.5	-740.35	64	SEG36	822.5	-277.2
25	SEG3/Strobe3	-822.5	-830.35	65	SEG37	822.5	-187.2
26	SEG4/Strobe4	-822.5	-920.35	66	SEG38	822.5	-97.2
27	SEG5/Strobe5	-822.5	-1010.35	67	SEG39	822.5	-7.2
28	SEG6/Strobe6	-822.5	-1100.35	68	SEG40	822.5	82.8
29	SEG7/Strobe7	-822.5	-1190.35	69	SEG41	822.5	172.8
30	NC	-	-	70	SEG42	822.5	262.8
31	NC	-	-	71	SEG43	822.5	352.8
32	SEG8/Strobe8	-815.35	-1317.5	72	C1A	822.5	442.8
33	SEG9/Strobe9	-725.35	-1317.5	73	C1B	822.5	532.8
34	SEG10/Strobe10	-635.35	-1317.5	74	C2A	822.5	622.8
35	SEG11/Strobe11	-545.35	-1317.5	75	C2B	822.5	712.8
36	SEG12/Strobe12	-455.35	-1317.5	76	V07	822.5	802.8
37	SEG13/Strobe13	-365.35	-1317.5	77	V15	822.5	892.8
38	SEG14/Strobe14	-275.35	-1317.5	78	V22	822.5	982.8
39	SEG15/Strobe15	-185.35	-1317.5	79	NC	-	-
40	SEG16	-95.35	-1317.5	80	NC	-	-

(Continuation)

Pin NO.	Symbol	X	Y	Pin NO.	Symbol	X	Y
81	NC	-	-	91	SEG51/PorC.7	-23.5	1327.5
82	V30	809.15	1327.5	92	SEG52/PorB.0	-113.5	1327.5
83	VSS	708.5	1327.5	93	SEG53/PorB.1	-203.5	1327.5
84	SEG44/PorC.0	606.5	1327.5	94	SEG54/PorB.2	-293.5	1327.5
85	SEG45/PorC.1	516.5	1327.5	95	SEG55/PorB.3	-383.5	1327.5
86	SEG46/PorC.2	426.5	1327.5	96	SEG56/PorB.4	-473.5	1327.5
87	SEG47/PorC.3	336.5	1327.5	97	SEG57/PorB.5	-568.5	1327.5
88	SEG48/PorC.4	246.5	1327.5	98	SEG58/PorB.6	-663.5	1327.5
89	SEG49/PorC.5	156.5	1327.5	99	SEG59/PorB.7	-765.6	1327.5
90	SEG50/PorC.6	66.5	1327.5	100	NC	-	-

NOTE

For PCB layout, the die pad must be connected to VSS (i.e., the IC substrate must be connected to VSS or keep floating).