ePS5005

**RISC II Series
Microcontroller**

Product Specification

Doc. VERSION 1.0

ELAN MICROELECTRONICS CORP.
November 2010



Trademark Acknowledgments:

IBM is a registered trademark and PS/2 is a trademark of IBM.

Windows is a trademark of Microsoft Corporation.

ELAN and ELAN logo  are trademarks of ELAN Microelectronics Corporation.

Copyright © 2006~2010 by **ELAN Microelectronics Corporation**

All Rights Reserved

Printed in Taiwan

The contents of this specification are subject to change without further notice. ELAN Microelectronics assumes no responsibility concerning the accuracy, adequacy, or completeness of this specification. ELAN Microelectronics makes no commitment to update, or to keep current the information and material contained in this specification. Such information and material may change to conform to each confirmed order.

In no event shall ELAN Microelectronics be made responsible for any claims attributed to errors, omissions, or other inaccuracies in the information or material contained in this specification. ELAN Microelectronics shall not be liable for direct, indirect, special incidental, or consequential damages arising from the use of such information or material.

The software (if any) described in this specification is furnished under a license or nondisclosure agreement, and may be used or copied only in accordance with the terms of such agreement.

ELAN Microelectronics products are not intended for use in life support appliances, devices, or systems. Use of ELAN Microelectronics product in such applications is not supported and is prohibited.

NO PART OF THIS SPECIFICATION MAY BE REPRODUCED OR TRANSMITTED IN ANY FORM OR BY ANY MEANS WITHOUT THE EXPRESSED WRITTEN PERMISSION OF ELAN MICROELECTRONICS.



ELAN MICROELECTRONICS CORPORATION

Headquarters:

No. 12, Innovation 1st Road
Hsinchu Science Park
Hsinchu, TAIWAN 30076
Tel: +886 3 563-9977
Fax: +886 3 563-9966
webmaster@emc.com.tw
<http://www.emc.com.tw>

Hong Kong:

Elan (HK) Microelectronics Corporation, Ltd.
Flat A, 19F., World Tech Centre 95
How Ming Street, Kwun Tong
Kowloon, HONG KONG
Tel: +852 2723-3376
Fax: +852 2723-7780

USA:

Elan Information Technology Group (U.S.A.)
PO Box 601
Cupertino, CA 95015
U.S.A.
Tel: +1 408 366-8225
Fax: +1 408 366-8225

Korea:**Elan Korea Electronics Company, Ltd.**

301 Dong-A Building
632 Kojan-Dong, Namdong-ku
Incheon City, KOREA
Tel: +82 32 814-7730
Fax: +82 32 813-7730

Shenzhen:**Elan Microelectronics Shenzhen, Ltd.**

3F, SSMEC Bldg., Gaoxin S. Ave. I
Shenzhen Hi-tech Industrial Park
(South Area), Shenzhen
CHINA 518057
Tel: +86 755 2601-0565
Fax: +86 755 2601-0500
elan-sz@elanic.com.cn

Shanghai:**Elan Microelectronics Shanghai, Ltd.**

3F, Building #13
No. 116, Lane 572, Bibo Road
Zhangjiang Hi-Tech Park
Shanghai, CHINA 201203
Tel: +86 21 5080-3866
Fax: +86 21 5080-4600
elan-sh@elanic.com.cn

Contents

1	General Description	1
2	Features	1
3	Block Diagram	3
4	Pin Assignment	4
5	Pin Description	5
6	Code Option	6
7	MCU System	8
	7.1 Power-up and Reset Timing	8
	7.2 MCU Operation Timing	9
8	ROM and RAM	10
	8.1 Program ROM Map	10
	8.2 RAM Map	10
	8.2.1 Unbanked RAM	10
	8.2.2 Banked General RAM	10
	8.3 LCD RAM Map	11
9	Electrical Characteristics	12
	9.1 VDD = 1.5V Electrical Characteristics	12
10	Application Circuits	14

Specification Revision History

Doc. Version	Revision Description	Date
0.1	Initial version	2006/08/03
0.2	Modified the LCD RAM Map	2007/07/02
0.3	1. Modified the max. supply voltage on Section 9. 2. Modified the supply current on Section 9. 3. Added a Note on Section 6 Code Option.	2008/08/26
1.0	1. Deleted the VDD=3.0V Electrical Characteristics entries. 2. Modified the Operating voltage to 1.5V only	2010/11/03

1 General Description

The **ePS5005** is an 8-bit RISC MCU embedded with an 11×60 LCD driver along with two 8-bit timers, one 16-bit general timer, and a watchdog timer. It also has on-chip 512 bytes RAM and 16K words program ROM. It is highly ideal for advance scientific calculator application, particularly those requiring high performance and low cost solution.

The MCU core is one of ELAN's second generation RISC based IC's, known as RISC II (RII) series. The core was specifically designed for low power and portable device applications. The ePS5005 also supports Fast, Slow and Idle modes, as well as Sleep mode to enhance its low power consumption features.

IMPORTANT NOTES !

- Do not use Register BSR (05h) Bit 7 ~ Bit 3.
- Do not use Register BSR1 (07h) Bit 7 ~ Bit 3.
- Check the range of BSR (05h) and BSR1 (07h) are only 0x00~0x03.
- Do not use LCD RAM 3Ch ~ 3Fh.
- Do not use Registers JDNZ at FSR1 (04h) special register.

2 Features

MCU

- 8 bit RISC MCU
- Operating voltage: 1.2V ~ 1.8V
- Clock Source: Dual system clock
 - Low-frequency: 32kHz Internal RC oscillator / External RC oscillator / Crystal oscillator
 - High-frequency: 200kHz / 300kHz / 500kHz External RC oscillator
- One Instruction cycle time = 2 × System clock time
- Program ROM addressing: 16K words max.
- 128 bytes un-banked RAM and Working RAM
- 128 bytes un-banked RAM including special registers and common registers
- 4×128 bytes banked RAM
- 32-level RAM stack
- Lookup Table function is fast and efficient when combined with Repeat instruction

- Register-to-Register move instruction
- Compare and Branch in one instruction (two cycles)
- Single Repeat function (256 max. repeat times)
- Decimal ADD and SUB instruction
- Full range CALL and JUMP ability (two cycles)

Peripheral

- 24 general I/O pins (Port A, Port B, Port C)
- 11/10/5 COM × 40 SEG LCD driver (embedded)
- One 16-bit timer (Timer 0)
- One 8-bit timer (Timer 1) with wake-up function
- One 8-bit timer (Timer 2)
- One 8-bit Watchdog Timer
- Key I/O function with 64 keys max.

Internal Specification

- Watchdog Timer with its own on-chip RC oscillator
- MCU operation modes: Sleep Mode, Idle Mode, Slow Mode, and Fast Mode
- Supports RC oscillation and crystal oscillation for system clock
- MCU Wake-up function consists of input wake up and Timer 1 wake up
- MCU interrupt function consists of Input port interrupt and Timer interrupt (Timers 0 ~ 2)
- MCU reset function includes power-on reset, RSTB pin reset, and Watchdog Timer reset

3 Block Diagram

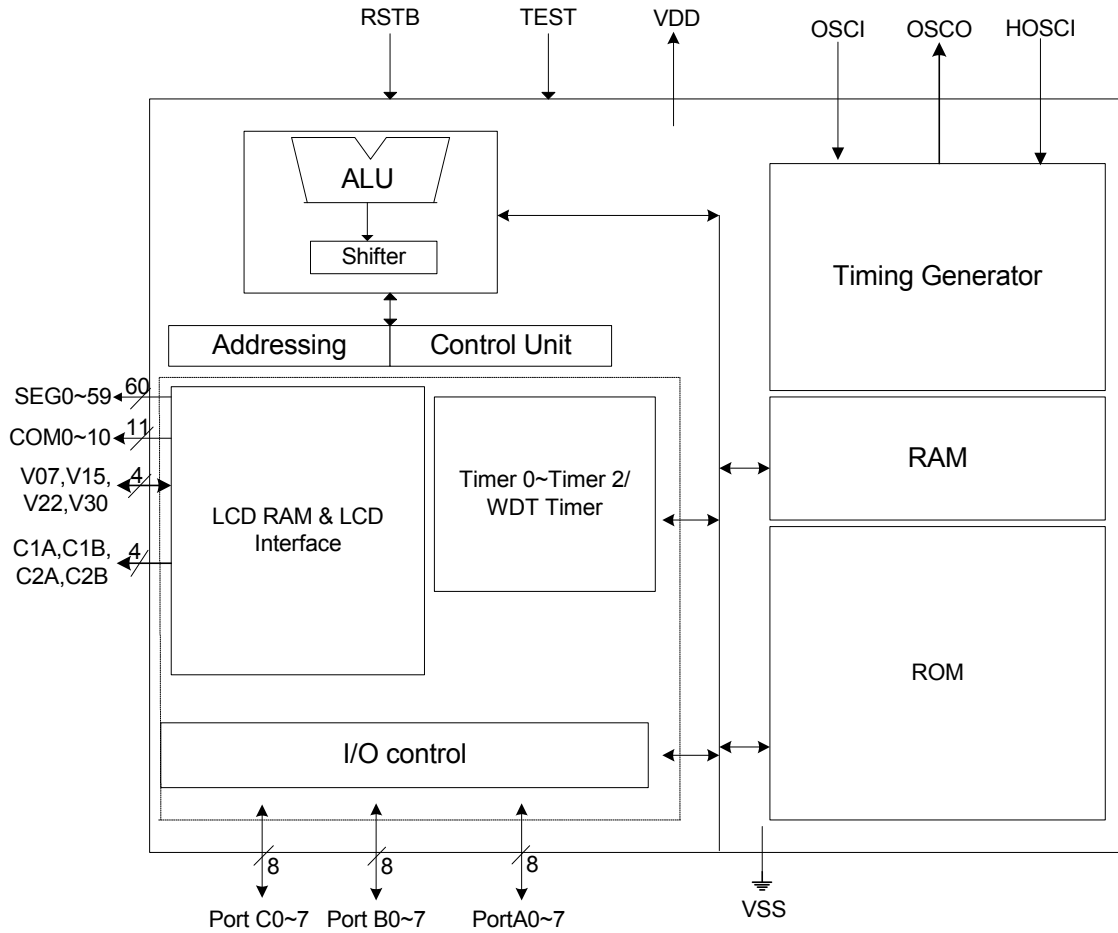

Figure 3-1 ePS5005 Block Diagram

4 Pin Assignment

■ 94-pin Chip form

No.	Pin Name	No.	Pin Name	No.	Pin Name	No.	Pin Name
1	NC	41	NC	81	SEG30	121	NC
2	NC	42	NC	82	SEG31	122	NC
3	RESETB	43	NC	83	SEG32	123	NC
4	VDD	44	NC	84	SEG33	124	NC
5	OSCO	45	NC	85	SEG34	125	NC
6	OSCI	46	NC	86	SEG35	126	NC
7	HOSCI	47	NC	87	SEG36	127	NC
8	VSS	48	NC	88	SEG37	128	NC
9	COM10	49	NC	89	SEG38	129	NC
10	COM9	50	NC	90	SEG39	130	NC
11	COM8	51	NC	91	SEG40	131	NC
12	COM7	52	NC	92	SEG41	132	NC
13	COM6	53	NC	93	SEG42	133	NC
14	COM5	54	SEG19	94	SEG43	134	NC
15	COM4	55	SEG20	95	SEG44/PortC.0	135	NC
16	COM3	56	SEG21	96	SEG45/PortC.1	136	PortA.0
17	COM2	57	SEG22	97	SEG46/PortC.2	137	PortA.1
18	COM1	58	SEG23	98	SEG47/PortC.3	138	PortA.2
19	COM0	59	SEG24	99	SEG48/PortC.4	139	PortA.3
20	SEG0/Strobe0	60	SEG25	100	SEG49/PortC.5	140	TEST
21	SEG1/Strobe1	61	SEG26	101	SEG50/PortC.6	141	PortA.4
22	SEG2/Strobe2	62	SEG27	102	SEG51/PortC.7	142	PortA.5
23	SEG3/Strobe3	63	SEG28	103	SEG52/PortB.0	143	PortA.6
24	SEG4/Strobe4	64	SEG29	104	SEG53/PortB.1	144	PortA.7
25	SEG5/Strobe5	65	NC	105	SEG54/PortB.2	145	NC
26	SEG6/Strobe6	66	NC	106	SEG55/PortB.3	146	NC
27	SEG7/Strobe7	67	NC	107	SEG56/PortB.4	147	NC
28	SEG8/Strobe8	68	NC	108	SEG57/PortB.5	148	NC
29	SEG9/Strobe9	69	NC	109	SEG58/PortB.6	149	NC
30	SEG10/Strobe10	70	NC	110	SEG59/PortB.7	150	NC
31	SEG11/Strobe11	71	NC	111	C1A	151	NC
32	SEG12/Strobe12	72	NC	112	C1B	152	NC
33	SEG13/Strobe13	73	NC	113	C2A	153	NC
34	SEG14/Strobe14	74	NC	114	C2B	154	NC
35	SEG15/Strobe15	75	NC	115	V30	155	NC
36	SEG16	76	NC	116	V22	156	NC
37	SEG17	77	NC	117	V15	157	NC
38	SEG18	78	NC	118	V07	158	NC
39	NC	79	NC	119	NC	159	NC
40	NC	80	NC	120	NC	160	NC

5 Pin Description

5.1 MCU System Pins (7 Pins)

Name	I/O/P Type	Description	Note
VDD	P	Digital and Analog positive power supply, the range is from 1.2V~1.8V. Connect to VSS through the capacitors (0.1μF).	–
VSS	P	Digital and Analog negative power supply.	–
RSTB	I	System reset pin. Low active	Int. pull-up
TEST	I	Test mode select pin (High active). For chip internal test only, Normal connect to VSS.	Int. Pull Down
OSCI	I	External RC oscillator /Crystal oscillator connecting pin	Ext. R to VDD
OSCO	O	Crystal oscillator connecting pin	–
HOSCI	I	Hi-Speed RC oscillator connecting pin.	Ext. R to VDD

5.2 Embedded LCD Pins (79 Pins)

Name	I/O/P Type	Description	Note
COM0~COM10	O	LCD common signal output pin	–
SEG0~SEG15	O	LCD segment signal output pin shared with key strobe 0~15	–
SEG16~ SEG43	O	LCD segment signal output pin	–
SEG44~SEG51/ PortC.0~7	I/O	LCD segment signal output pin or I/O pin; define by code option	–
SEG52~SEG59/ PortB.0~7	I/O	LCD segment signal output pin or I/O pin; define by code option	–
C1A,C1B	–	LCD voltage charge-pump pin. Connect 0.1 μF between C1A and C1B.	–
C2A,C2B	–	LCD voltage charge-pump pin. Connect 0.1 μF between C2A and C2B.	–
V30,V22,V15,V07	O	LCD bias Pin. Connect 0.1 μF to Vss	–

5.3 I/O Port (8 Pins)

Port	Bit	Function	I/O Type	Power Source	Description	Note
Port A	Bits 3~0 (for key scan)	General Input	I	VDD	Key input	Int. Pull up (R1: small resistor, R2: Large resistor) controllable
		Interrupt and wake up	I	VDD	Input port interrupt and wake up pin	
		General Output	O	VDD	–	
	Bits 7~4	General Input	I	VDD	–	Int. Pull up (R2: Large resistor) controllable
		Interrupt and wake up	I	VDD	Input port interrupt and wake up pin	
		General Output	O	VDD	–	

6 Code Option

Located at Address 0x000C~0x000F of Program ROM

- Initial mode after reset:
 - Select “Slow” mode or “Fast” mode

NOTE

Suggest that user setting “Slow mode” for Initial mode after reset.

- The Operating voltage option:
 - Only has “1.5V”
- Low Frequency Oscillator:
 - Select “External RC” oscillator or “Crystal” oscillator or “Internal RC” oscillator
- Maximum duty ratio option:
 - Select “1/10” duty or “1/11” duty or “1/5” duty
- Port B.0 control bit (SEG52):
 - Select “LCD segment signal output” or “general I/O function”
- Port B.1 control bit (SEG53):
 - Select “LCD segment signal output” or “general I/O function”
- Port B.2 control bit (SEG54):
 - Select “LCD segment signal output” or “general I/O function”
- Port B.3 control bit (SEG55):
 - Select “LCD segment signal output” or “general I/O function”
- Port B.4 control bit (SEG56):
 - Select “LCD segment signal output” or “general I/O function”
- Port B.5 control bit (SEG57):
 - Select “LCD segment signal output” or “general I/O function”
- Port B.6 control bit (SEG58):
 - Select “LCD segment signal output” or “general I/O function”
- Port B.7 control bit (SEG59):
 - Select “LCD segment signal output” or “general I/O function”
- Port C.0 control bit (SEG44):
 - Select “LCD segment signal output” or “general I/O function”

- Port C.1 control bit (SEG45):
 - Select “LCD segment signal output” or “general I/O function”
- Port C.2 control bit (SEG46):
 - Select “LCD segment signal output” or “general I/O function”
- Port C.3 control bit (SEG47):
 - Select “LCD segment signal output” or “general I/O function”
- Port C.4 control bit (SEG48):
 - Select “LCD segment signal output” or “general I/O function”
- Port C.5 control bit (SEG49):
 - Select “LCD segment signal output” or “general I/O function”
- Port C.6 control bit (SEG50):
 - Select “LCD segment signal output” or “general I/O function”
- Port C.7 control bit (SEG51):
 - Select “LCD segment signal output” or “general I/O function”

7 MCU System

7.1 Power-up and Reset Timing

■ Power-on Reset Timing:

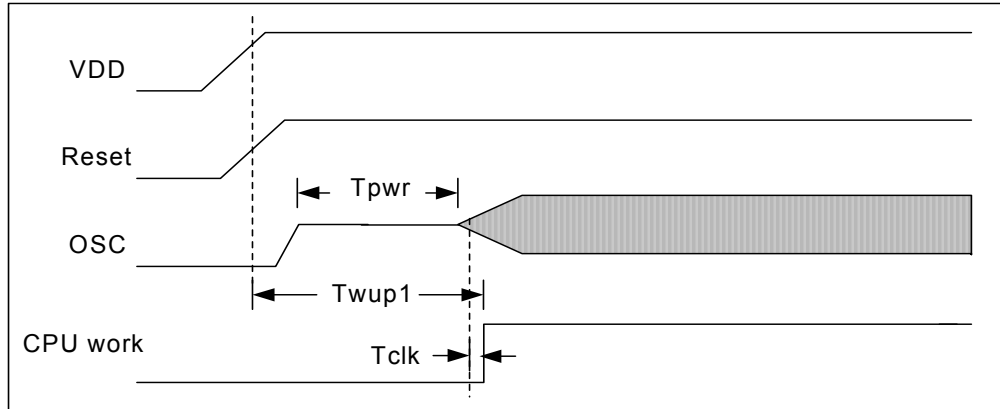

Figure 7-1 Power-on Reset Timing Diagram

■ Sleep Mode Wake-up Timing:

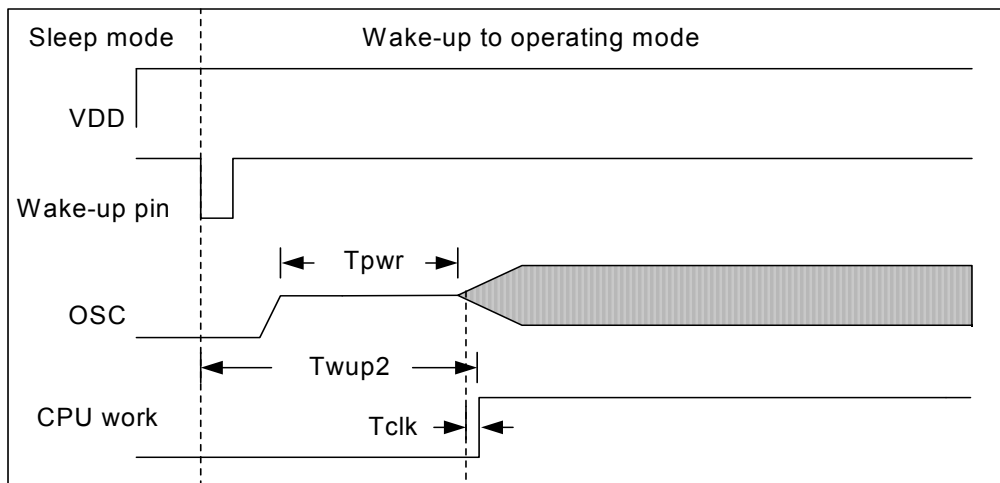

Figure 7-2 Sleep Mode Wake-up Timing Diagram

Condition: Vdd = 1.5V, Cosc = 20pF and Ta = 25°C

Symbol	Characteristics	Min.	Typ.	Max.	Unit
Tpwr	Oscillator start up time (Crystal)	-	480	780	ms
Twup1	CPU warm up time (Power-on reset)	-	500	800	ms
Twup2	CPU warm up time (Sleep mode wakeup)	-	485	785	ms
Tclk	Detect slow clock time	-	1.0	1.1	ms

7.2 MCU Operation Timing

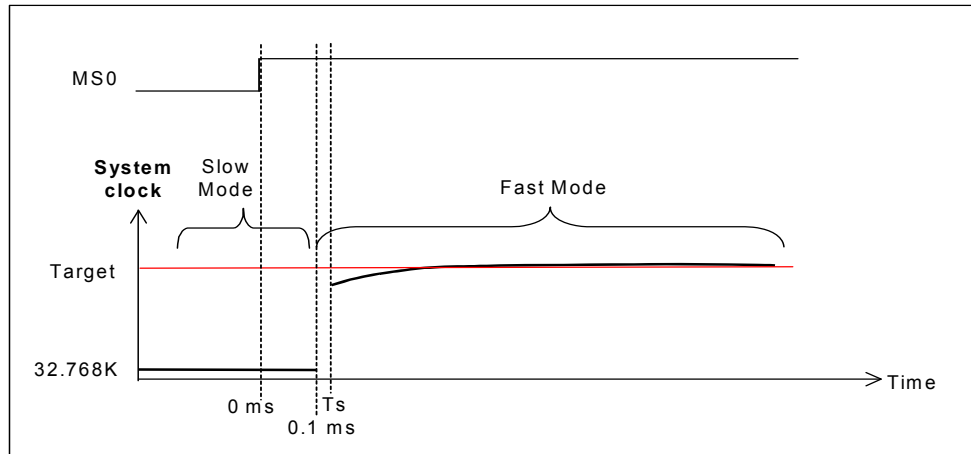

Figure 7-3 Slow Mode to Fast Mode Timing Diagram

- Note:**
1. Slow Mode switches to Fast Mode at Time=0ms.
 2. System clock will switch to Fast Mode after a delay of 0.1ms by oscillator and enters into Fast Mode (i.e., system clock will be at 200, 300, or 500kHz).
 3. High frequency RC will be stabilized at Time=Ts (around 15 μ s~30 μ s).

8 ROM and RAM

8.1 Program ROM Map

ROM Size = 16K Words	
Address	Description
0000h 000Bh	Interrupt Vector (12 words)
000Ch 000Fh	Code Option (4 words)
0010h 001Fh	Test Program (16 words)
0020h 3FFFh	Program or Fixed data region

8.2 RAM Map

RAM Size: 88 Bytes + 4 Bank × 128 Bytes = 600 Bytes

8.2.1 Unbanked RAM

Address	Unbanked
00h 12h	Special Registers
13h 1Fh	General purpose RAM
20h 34h	Control Registers
35h 7Fh	General purpose RAM

8.2.2 Banked General RAM

Address	Bank 0	Bank 1	Bank 2	Bank 3
80h FFh	General Purpose RAM	General Purpose RAM	General Purpose RAM	General Purpose RAM

8.3 LCD RAM Map

■ 1/5 Duty

RAM Address LCDARL		COM0	COM1	COM2	COM3	COM4	-	-	-
		Bit 0	Bit 1	Bit 2	Bit 3	Bit 4	Bit 5	Bit 6	Bit 7
SEG0	00H								
:	:								
SEG59	3BH								

■ 1/10 Duty

RAM Address LCDARL		COM 0	COM 1	COM 2	COM 3	COM 4	COM 5	COM 6	COM 7
		Bit 0	Bit 1	Bit 2	Bit 3	Bit 4	Bit 5	Bit 6	Bit 7
SEG0	00H								
:	:								
SEG59	3BH								

RAM Address LCDARL		COM 8	COM 9	-
		Bit 0	Bit 1	Bit 2
SEG0	40H			
:	:			
SEG59	7BH			

■ 1/11 Duty

RAM Address LCDARL		COM 0	COM 1	COM 2	COM 3	COM 4	COM 5	COM 6	COM 7
		Bit 0	Bit 1	Bit 2	Bit 3	Bit 4	Bit 5	Bit 6	Bit 7
SEG0	00H								
:	:								
SEG59	3BH								

RAM Address LCDARL		COM 8	COM 9	COM 10
		Bit 0	Bit 1	Bit 2
SEG0	40H			
:	:			
SEG59	7BH			

9 Electrical Characteristics

9.1 VDD = 1.5V Electrical Characteristics

■ Absolute Maximum Ratings

Items	Sym.	Condition	Limits	Unit
Supply voltage	VDD	–	–0.3 to +2.0	V
Supply voltage for ICE	VCC	–	–0.3 to +3.6	
Input voltage (general input port)	VIN	–	–0.5 to VDD +0.5	V
Input voltage for ICE	VIN1	–	–0.5 to VCC +0.5	V
Operating temperature range	TOPR	–	–10 to +70	°C
Storage temperature range	TSTR	–	–55 to +125	°C

■ Recommended Operating Conditions

Items	Sym.	Condition	Limits	Unit
Supply voltage	VDD	–	1.2 to 1.8	V
Supply voltage for ICE	VCC	–	2.2 to 3.6	
Input voltage	VIH	–	VDD x 0.9 to VDD	V
	VIL	–	0 to VDD x 0.1	V
Input voltage for ICE	VIH	–	VDD x 0.9 to VDD	V
	VIL	–	0 to VDD x 0.1	V
Operating temperature	TOPR	–	–10 to +70	°C

■ DC Electrical Characteristics (Condition: Ta=25°C, VDD = 1.5V)

Parameter	Sym.	Condition		Min	Typ	Max	Unit
CLOCK	F _{HOSC}	Main-clock frequency	RC OSC., R=910kΩ	140	200	260	kHz
			RC OSC., R=560kΩ	210	300	390	
			RC OSC., R=330kΩ	350	500	650	
	F _{osc}	Sub-clock frequency	RC OSC., R=2.2MΩ	24.6	32.8	41	kHz
			Internal RC OSC.	24.6	32.8	41	
			Crystal OSC.	-	32.768	-	
Supply Current	I _{dd1}	Sleep mode	VDD=1.5V, no load	-	-	1	μA
	I _{dd2}	Idle mode	VDD=1.5V RC OSC, LCD enabled, no load	-	3	4	
			VDD=1.5V, X'tal OSC, LCD enabled, no load	-	2.5	3.5	
	I _{dd4}	Slow mode	VDD=1.5V, RC OSC, LCD enabled, no load, utility rate of RAM 25%	-	4	6	
			VDD=1.5V, X'tal OSC, LCD enabled, no load, utility rate of RAM 25%	-	4	5.5	
	I _{dd6}	Fast mode	VDD=1.5V, F _{HOSC} =200kHz, LCD enabled, no load	-	16	22	
			VDD=1.5V, F _{HOSC} =300kHz, LCD enabled, no load	-	20	35	
			VDD=1.5V, F _{HOSC} =500kHz, LCD enabled, no load	-	30	50	



Parameter	Sym.	Condition		Min	Typ	Max	Unit
Input Voltage	VIH1	PA[0:7] (as general input port)		VDD×0.7	-	VDD	V
	VIL1			0	-	VDD×0.3	
Input Threshold Voltage (Schmitt)	VT+	RSTB		0.5×VDD	-	0.75×VDD	V
	VT-			0.2×VDD	-	0.4×VDD	
Input Leakage Current	IIL	ALL Input port (without pull up/down resistor) Vin= VDD or GND		-	-	±1	μA
Large Pull-up Resistance	RPU5	RSTB	Vin=GND	300	450	750	KΩ
Small Pull-up Resistance	RPU6	RSTB	Vin=1V	10	30	60	KΩ
Large Pull-down Resistance	RPD1	TEST	Vin=VDD	250	500	750	KΩ
Small Pull-down Resistance	RPD2	TEST	Vin=0.5V	3	6	12	KΩ
Data Retention Voltage	Vret	-		1.2	-	-	V
Power On Reset Voltage	Vpor	-		0.9	1.0	1.1	V
LCD Enabled							
Output Current	IOH1	PA[0:7], PB[0:7], PC[0:7] (as general output port)	VDD=1.5V, VOH=1.2V, LCD enabled	-0.3	-0.5	-0.9	mA
	IOL1		VDD=1.5V, VOL=0.2V, LCD enabled	0.6	0.9	1.3	
Large Pull-up Resistance	RPU1	PA[0:7]	Key high resistance, pulled up by R2, LCD enabled, Vin2=0.5V	300	550	1100	KΩ
	RPU3	PB[0:7], PC[0:7]	Vin=0.5V, LCD enabled	90	180	360	
Small Pull-up Resistance	RPU2	PA[0:3]	Key high resistance, pulled up by R2//R1, LCD enabled, Vin2=0 V	50	90	180	KΩ
	RPU4	PA[4:7]	Vin=1V, LCD enabled	20	35	70	
LCD Driver							
LCD Display Output ON-resistance	ROC	Com[0:10]	VOH=V30 ± 0.1V	0.35	0.4	0.50	KΩ
			VOM=V22 ± 0.1V	0.55	0.65	0.75	
			VOM=V07 ± 0.1V	0.35	0.4	0.45	
			VOL=0.1V	0.25	0.3	0.35	
LCD Display Output ON-resistance	ROS	Seg[0:59]	VOH=V30 ± 0.1V	0.35	0.4	0.50	KΩ
			VOM=V15 ± 0.1V	0.45	0.60	0.85	
			VOL=0.1V	0.25	0.3	0.35	
Strobe Output ON-resistance	ROP	Seg[0:15] (as key strobe)	V=VDD-0.2V	100	200	350	KΩ
	RON		V=0.2V	0.7	1.3	2	

10 Application Circuits

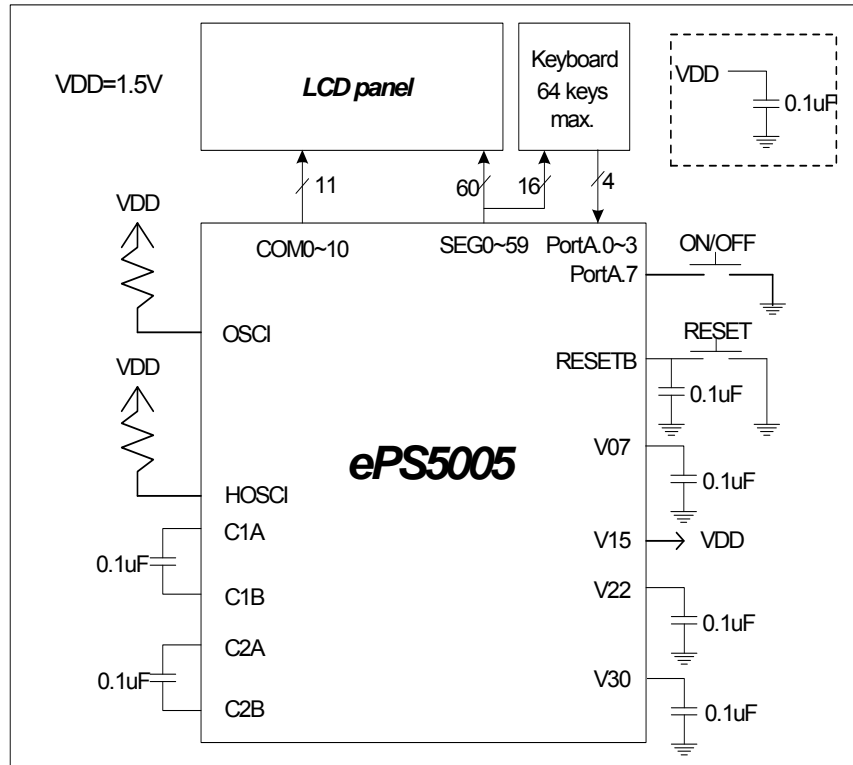

Figure 10-1 VDD=1.5V Application Circuit Diagram