

---

# ePH1382

**Handwriting  
Recognition  
Microcontroller**

# Product Specification

**DOC. VERSION 0.2**

**ELAN MICROELECTRONICS CORP.**

May 2007

---



**Trademark Acknowledgments:**

IBM is a registered trademark and PS/2 is a trademark of IBM.

Windows is a trademark of Microsoft Corporation.

ELAN and ELAN logo  are trademarks of ELAN Microelectronics Corporation.

Copyright © 2007 by ELAN Microelectronics Corporation

All Rights Reserved

Printed in Taiwan, ROC

The contents of this specification are subject to change without further notice. ELAN Microelectronics assumes no responsibility concerning the accuracy, adequacy, or completeness of this specification. ELAN Microelectronics makes no commitment to update, or to keep current the information and material contained in this specification. Such information and material may change to conform to each confirmed order.

In no event shall ELAN Microelectronics be made responsible for any claims attributed to errors, omissions, or other inaccuracies in the information or material contained in this specification. ELAN Microelectronics shall not be liable for direct, indirect, special incidental, or consequential damages arising from the use of such information or material.

The software (if any) described in this specification is furnished under a license or nondisclosure agreement, and may be used or copied only in accordance with the terms of such agreement.

ELAN Microelectronics products are not intended for use in life support appliances, devices, or systems. Use of ELAN Microelectronics product in such applications is not supported and is prohibited.

NO PART OF THIS SPECIFICATION MAY BE REPRODUCED OR TRANSMITTED IN ANY FORM OR BY ANY MEANS WITHOUT THE EXPRESSED WRITTEN PERMISSION OF ELAN MICROELECTRONICS.



## ELAN MICROELECTRONICS CORPORATION

**Headquarters:**

No. 12, Innovation Road 1  
Hsinchu Science Park  
Hsinchu, TAIWAN 308  
Tel: +886 3 563-9977  
Fax: +886 3 563-9966  
<http://www.emc.com.tw>

**Hong Kong:**

**Elan (HK) Microelectronics Corporation, Ltd.**  
Flat A, 19F., World Tech Centre  
95 How Ming Street, Kwun Tong  
Kowloon, HONG KONG  
Tel: +852 2723-3376  
Fax: +852 2723-7780  
[elanhk@emc.com.hk](mailto:elanhk@emc.com.hk)

**USA:**

**Elan Information Technology Group (U.S.A.)**  
P.O. Box 601  
Cupertino, CA 95015  
U.S.A.  
Tel: +1 408 366-8225  
Fax: +1 408 366-8225

**Shenzhen:**

**Elan Microelectronics Shenzhen, Ltd.**  
3F, SSMEC Bldg., Gaoxin S. Ave. I  
Shenzhen Hi-tech Industrial Park  
(South Area), Shenzhen  
CHINA 518057  
Tel: +86 755 2601-0565  
Fax: +86 755 2601-0500

**Shanghai:**

**Elan Microelectronics Shanghai, Ltd.**  
#23, Zone 115, Lane 572, Bibo Rd.  
Zhangjiang Hi-Tech Park  
Shanghai, CHINA 201203  
Tel: +86 21 5080-3866  
Fax: +86 21 5080-4600

# Contents

<b>1</b>	<b>Introduction</b> .....	<b>1</b>
<b>2</b>	<b>Features</b> .....	<b>1</b>
<b>3</b>	<b>Block Diagram</b> .....	<b>1</b>
<b>4</b>	<b>Pin Assignment</b> .....	<b>2</b>
4.1	LQFP 44 Pins .....	2
4.2	CSP (Chip Size Package) 24 Pins .....	3
4.4	Ordering Information .....	4
<b>5</b>	<b>Pin Description</b> .....	<b>4</b>
<b>6</b>	<b>Interface Control Timing Description</b> .....	<b>5</b>
6.1	UART Interface Control (9600, N, 8, 1) .....	5
<b>7</b>	<b>Pin Option Description</b> .....	<b>5</b>
<b>8</b>	<b>Electrical Characteristic</b> .....	<b>6</b>
8.1	Absolute Maximum Ratings .....	6
8.2	Recommended Operating Conditions .....	6
8.3	DC Electrical Characteristics .....	6
8.4	A/D Conversion .....	7
8.5	AC Electrical Characteristics .....	7
<b>9</b>	<b>Power-up and Reset Timing</b> .....	<b>8</b>
<b>10</b>	<b>Application Circuit</b> .....	<b>9</b>
10.1	UART Interface Application Circuit (with 32.768kHz Crystal) .....	9
10.2	UART Interface Application Circuit (with 32.768kHz External Clock) .....	10
10.3	Touch Panel and YP, XP, YN, and XN Layout Format .....	11
<b>11</b>	<b>HWRE Software Specification</b> .....	<b>12</b>
11.1	HWRE Software Description .....	12
11.2	Communication Protocol and Command List .....	12
11.2.1	Communication Interface: UART .....	12
11.2.2	Command Timing Request .....	12
11.2.3	Commands from Host (see Section 11.3 for details) .....	13
11.2.4	Responses from ePH1382 (see Section 11.4 for details) .....	14
11.3	Commands from Host Specifications .....	14
11.3.1	Wake up ePH1382 (0x33; 8 Bytes) .....	14
11.3.2	Set Character Recognition Mode (0x10; 8 Bytes) .....	14
11.3.3	Set Inking Transmit Switch (0x14; 8 Bytes) .....	16
11.3.4	Set Pen-up (Lifting of Stylus) Waiting Time (0x1A; 8 Bytes) .....	16
11.3.5	Immediately Perform Recognition before Time out (0x1B; 8 Bytes) .....	17
11.3.6	Host Ready (0x1C; 8 Bytes) .....	17



11.3.7 Set Even Numbered Package for Recognizing Characters (0x1D; 8 Bytes).... 18

11.3.8 Pen-up (Lifting of Stylus) Time-out Offset (0x1E; 8 Bytes)..... 18

11.3.9 Access the HWRE Firmware Version (0x40; 8 Bytes) ..... 19

11.3.10 Output with Different Code Table (0x41; 8 Bytes)..... 19

11.3.11 Software Reset (0x42; 8 Bytes) ..... 20

11.3.12 Abort the Current Inking (0x43; 8 Bytes)..... 20

11.3.13 Calibration (0x44; 8 Bytes)..... 21

11.3.14 Set Writing Area Location (0x46; 8 Bytes) ..... 21

11.3.15 Set Recognition Mode/Graphic Mode (0x49; 8 Bytes)..... 22

11.3.16 Set Power Saving Mode (0x4A; 8 Bytes)..... 22

11.3.17 Rotate Touch Panel (0x4C; 8 Bytes)..... 23

11.3.18 Set Stroke Over Waiting Time (0x4D; 8 Bytes) ..... 24

11.3.19 Output PROM/DROM Checksum (0xF0; 8 Bytes)..... 24

11.3.20 Single / Double Writing Area Switch (0x60; 8 Bytes) ..... 25

11.3.21 Set First/Second writing Area Location (0x61/0x62; 8 Bytes)..... 25

11.4 Responses from ePH1382 Specifications ..... 26

11.4.1 ACK\_ERROR (0x00; 8 Bytes)..... 26

11.4.2 Inking (Access to Written Input) Coordinates (0x16; 6 Bytes) ..... 26

11.4.3 Touch Panel Button Coordinates (0x17; 6 Bytes; 0xFF is Pen-up Signal)..... 27

11.4.4 Recognized Characters Array (0x18; Maximum 25 Bytes; Minimum 6 Bytes) .27

11.4.5 Exit from Power Saving Mode (0x33; 8 Bytes) ..... 28

11.4.6 Initial Power-on (0x42; 8 Bytes) ..... 29

11.4.7 ACK\_OK (Carry Out Host Command; 8 Bytes) ..... 30

11.5 Checksum Program..... 30

**12 Package Outline Drawing ..... 31**

**13 Tape Reel Specification ..... 32**

### Specification Revision History

Specification Revision History		
Doc. Version	Revision Description	Date
0.1	ePH1382 Initial Specification	2007/05/28
0.2	1. Modified the LQFP44 pin out 2. Removed the ECR mode	2007/05/30

## 1 Introduction

The ePH1382 IC is an 8 bit RISC microcontroller embedded with a recognition core. When connected to an external resistance type touch panel, the IC becomes suitable for handwriting recognition application products, such as SMS, Stylus Remote Controller, mobile phones, handwriting input device, etc. The ePH1382 has low power consumption, low cost, and yet is capable of providing high performance rate of recognition. These quality features are vital when there is shorter lead-time in developing new handwriting recognition related products or pressure-sensitive screen input devices.

## 2 Features

Product No.	Package	Input	Output	Interface	Remarks
ePH1382	CSP/ LQFP44	1. Japanese SJIS Standard 2. Simplified Chinese 3. Hangul 4. ASCII 5. Gesture	Unicode	UART	1. Can recognize 10182 CJK characters. Hiragana & Katakana, 170 characters. 2. Can recognize up to 50 Chinese Pinyin characters, 2350 Hangul characters.

## 3 Block Diagram

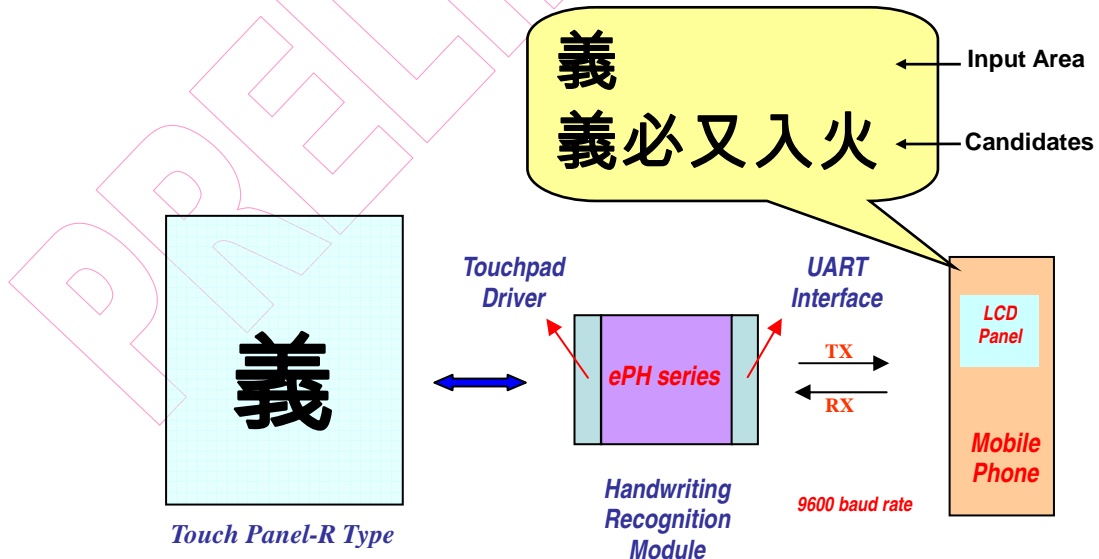

Figure 3-1 ePH1382 Block Diagram

## 4 Pin Assignment

### 4.1 LQFP 44 Pins

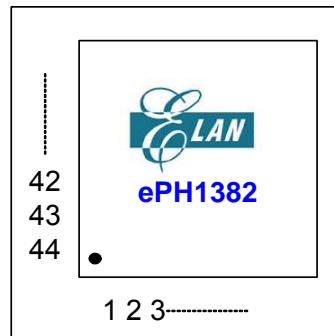

Figure 4-1 44-pin LQFP ePH1382 Pin Assignment

No.	Pin Name	No.	Pin Name	No.	Pin Name	No.	Pin Name
1	NC	12	YP	23	CE	34	NC
2	NC	13	XP	24	NC	35	NC
3	HTEST	14	YN (WKO)	25	NC	36	NC
4	PLLC	15	XN	26	NC	37	NC
5	OSCI	16	VREX	27	NC	38	NC
6	OSCO	17	VDD	28	NC	39	NC
7	RESETB	18	STEST	29	NC	40	NC
8	VDDA	19	NC	30	NC	41	NC
9	VSS	20	NC	31	NC	42	NC
10	TX	21	WKI	32	NC	43	NC
11	RX	22	NC	33	NC	44	NC

## 4.2 CSP (Chip Size Package) 24 Pins

Perspective view of the pin locations viewed from the top surface of the chip.  
Accurate package size:  $(4415 \pm 55) \mu\text{m} \times (3815 \pm 55) \mu\text{m}$ .

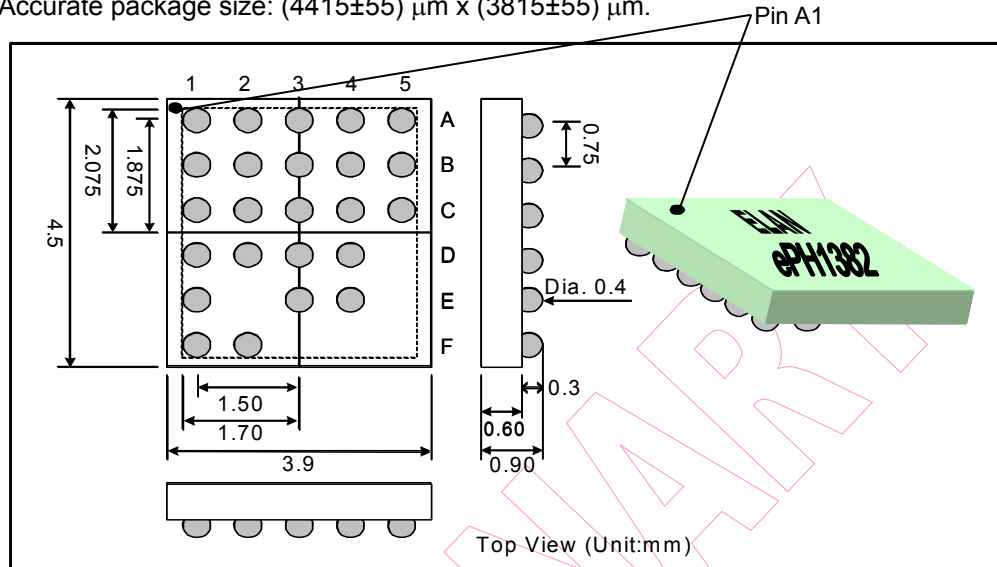

Figure 4-1a ePH1382 Pin Location

Perspective View from the Top Side						
Y Coordinate	X Coordinate	-1.500	-0.750	0.000	0.750	1.500
		1	2	3	4	5
1.875	A	NC	XP	VSS	VDDA	OSCI
1.125	B	NC	VREX	RX	OSCO	PLLCC
0.375	C	NC	VDD	YP	RESETB	HTEST
-0.375	D	STEST	NC	XN	TX	-
-1.125	E	NC	-	NC	YN (WKO)	-
-1.875	F	CE	WKI	-	-	-

Actual pin location and assignment as viewed from the bottom side of the chip.

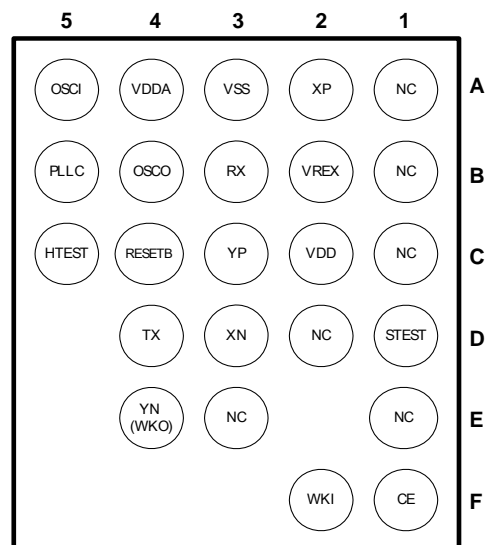

Figure 4-1b ePH1382 Actual Pin Location & Assignment (Viewed from the Bottom)



## 4.4 Ordering Information

Orderable Part Number	Package Type	
ePH1382SHS	CSP	Tray of 72
ePH1382KSHS		Tape reel of 2000
ePH1382AQS	LQFP44 10×10mm	

## 5 Pin Description

CSP	LQFP44	Name	I/O/P Type	Description
C2	17	VDD	P	Digital power supply ranging from 2.8V to 3.6V. It should be connected to VSS through a 0.1μF capacitor.
A3	9	VSS	P	Negative power supply
A4	8	VDDA	P	Analog power supply ranging from 2.8V to 3.6V. It should be connected to VSS through a 0.1μF capacitor.
C4	7	RESETB	I	System reset input pin with built-in pull up resistor (Typical value = 100KΩ). Should be connected to 1 GPIO pin.
C5	3	HTEST	I	Hardware testing. Normally connected to VSS.
A5	5	OSCI	I	Crystal or External Clock Source connector pin: <ul style="list-style-type: none"> <li>Crystal: Connect a 32.768kHz crystal and connect to VSS through a 20pF capacitor</li> <li>External Clock Source: Connect a 32.768kHz (±20ppm) clock signal through a 0.1μF capacitor (Clock V<sub>PP</sub>&gt;0.3V<sub>DD</sub>)</li> </ul>
B4	6	OSCO	O	Crystal or External Clock Source connector pin: <ul style="list-style-type: none"> <li>Crystal: Connect a 32.768kHz crystal and connect to VSS through a 20pF capacitor.</li> <li>External Clock Source: Keep the pin floating</li> </ul>
B5	4	PLLCC	I	PLL capacitor connector pin. Should be connected to VSS through a 0.047μF capacitor.
B2	16	VREX	I/O	Internal reference voltage for A/D converter. Should be connected to VSS through a 0.1μF capacitor.
F1	23	CE	I	“Floating” : Chip Enable “L” : Chip power down. UART interface pin will change to High-Z status.
D1	18	STEST	I	Software testing. Normally floating or connected to VDD.
D4	10	TX	O	UART Interface Tx pin
B3	11	RX	I	UART Interface Rx pin
C3	12	YP	I	Touch screen Y direction positive pin
A2	13	XP	I	Touch screen X direction positive pin
E4	14	YN (WKO)	O	Touch screen Y direction negative pin. This pin should be connected to the host input pin. Such host input pin must be set as “non-pull-up” resistor type and provides a wake-up function.
D3	15	XN	O	Touch screen X direction negative pin
F2	21	WKI	I	Wake-up input pin. Host wakes up the ePH1382 from power saving mode through this pin.

## 6 Interface Control Timing Description

### 6.1 UART Interface Control (9600, N, 8, 1)

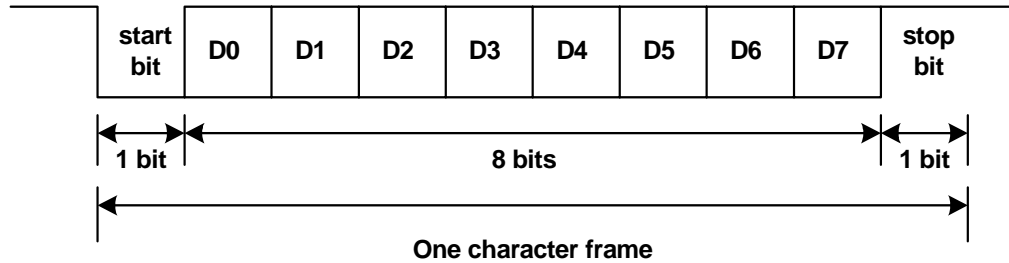

Figure 6-1 UART Interface Control Timing Diagram

## 7 Pin Option Description

- CE Pin Option



Chip Disabled

Chip Enabled

Figure 7-1 CE Pin Connection Option

## 8 Electrical Characteristic

### 8.1 Absolute Maximum Ratings

Items	Symbol	Condition	Limits	Unit
Supply Voltage	VDD	–	–0.3 to +3.6	V
Input Voltage (General Input Port)	VIN	–	–0.5 to VDD+0.5	V
Operating Temperature Range	TOPR	–	–20 to +80	°C
Storage Temperature Range	TSTR	–	–55 to +125	°C

### 8.2 Recommended Operating Conditions

Items	Symbol	Condition	Limits	Unit
Supply Voltage	VDD	–	2.8 to 3.6	V
	VDDA		2.8 to 3.6	
Input Voltage	VIH	–	VDD x 0.9 to VDD	V
	VIL	–	0 to VDD x 0.1	V
A/D Full-Scale Input Span	ADRG	Positive input– negative input	0 to VREX	V
Operating Temperature	TOPR	–	–20 to +80	°C

### 8.3 DC Electrical Characteristics

Condition: Ta=25°C, VDD= 3.0 ± 0.3V

Parameter	Symbol	Condition		Min	Type	Max	Unit
Clock	Fmain	Main-clock frequency		–	9.83	–	MHz
	Fsub	Sub-clock frequency	Crystal OSC	–	32.768	–	kHz
Supply Current	Idd2	Idle mode	VDD=3V, Crystal OSC.	–	5	8	μA
	Idd3	Fast mode	VDD=3V, Fmain=9.83 MHz, without touch panel load	–	2000	3000	
Input Voltage	VIH1	Input pin		VDD×0.7	–	VDD	V
	VIL1			0	–	VDD×0.3	
Input Threshold Voltage (Schmitt)	VT+	RESETB pin		0.5×VDD	–	0.75×VDD	V
	VT–			0.2×VDD	–	0.4×VDD	
Output Current	IOH1	Output pin	VDD=3V, VOH=2.4V	–1.1	–2.2	–3.3	mA
	IOL1		VDD=3V, VOL=0.2V	+1.1	+2.2	+3.3	
Input Leakage Current	IIL	ALL Input port (without pull-up/down resistor) Vin=VDD or GND		–	–	±1	μA
Touch Panel Pull Down Resistance	RPD3	DET=1, Xn pin	Vin=VDD, VDD=3V	25	50	100	KΩ
Data Retention Voltage	Vret	–		1.6	–	–	V
Power-on Reset Voltage	Vpor	–		1.4	1.5	1.6	V

## 8.4 A/D Conversion

VDD=3.0V, VDDA=3.0V, Ta=25°C, Fclk=12 × Fsample

Parameter	Symbol	Condition	Min	Type	Max	Unit
<b>Analog Input</b>						
Mux Leakage Current	Imux	On/off leakage current, Vin=0 or VDD	-	0.1	1	μA
<b>System Performance</b>						
Resolution	-	-	-	10	-	Bits
Integral Non-Linearity	INL	-	-2	-	+2	LSB
Differential Non-linearity	DNL	-	-2	-	+2	LSB
Offset Error	OErr	-	-4	-	+4	LSB
Gain Error	GErr	-	-4	-	+4	LSB
Missing Code	MC	-	-	-	-	Bit
VDDA Supply Current	Ivdd3	VDD=3.0V, VDDA=3.0V, Fsample=20kHz, ADEN=1, VRS=1	-	0.5	0.7	mA
	Ivdd4	ADEN=0, VRS=1	-	-	1	μA
Driver Current	IOH	Xp, Yp (VDD= 2.9 ± 0.3V) (Voh=VDD-0.2V)	-20	-30	-45	mA
Sink Current	IOL	Xn, Yn (VDD= 2.9 ± 0.3V) (Vol=0.2V)	+20	+30	+45	mA

## 8.5 AC Electrical Characteristics

Condition: Ta=25°C, VDD=3.0 ± 0.3V

Parameter	Symbol	Condition	Min	Type	Max	Unit
<b>A/D Conversion (VDD=3.0V, VDDA=3.0V, Ta=-10~+60°C)</b>						
Throughput Rate	-	VDD=3.0V, VDDA=3.0V	-	-	80	ksps
		VDD=2.4V, VDDA=2.4V	-	-	60	
Power Supply Rejection Ratio	PSRR1+	Power noise: 1kHz, 100mV	37	40	-	dB
	PSRR1-	Power noise: 1kHz, 100mV	43	46	-	
Signal to Noise Ratio	SNR	-	51	54	-	dB

## 9 Power-up and Reset Timing

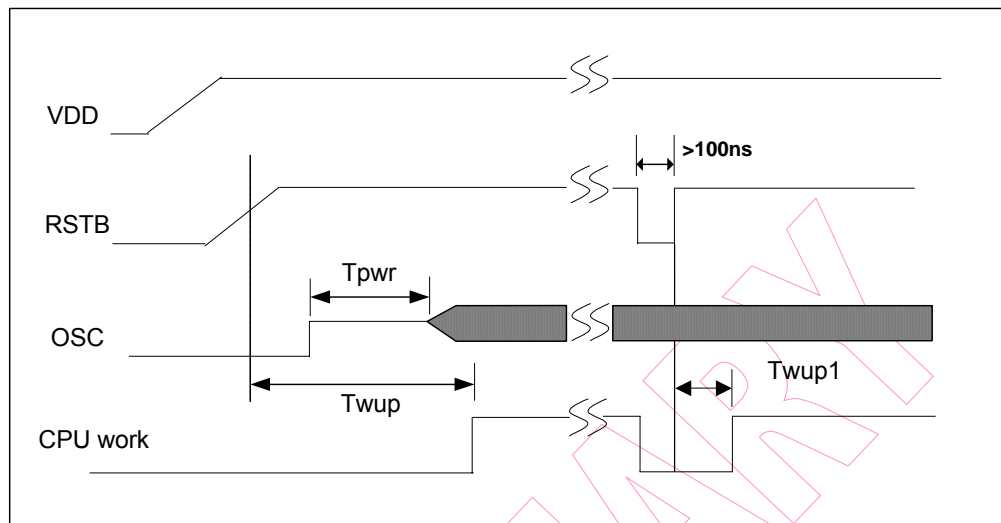

Figure 9-1 Power-up and Reset Timing Diagram

Symbol	Characteristics	Min.	Type	Max.	Unit
$T_{pwr}$	Oscillator start up time	100	226	300	ms
$T_{wup}$	CPU warm up time	260	340	550	ms
$T_{wup1}$	CPU reset time	18	22	44	ms

## 10 Application Circuit

### 10.1 UART Interface Application Circuit (with 32.768kHz Crystal)

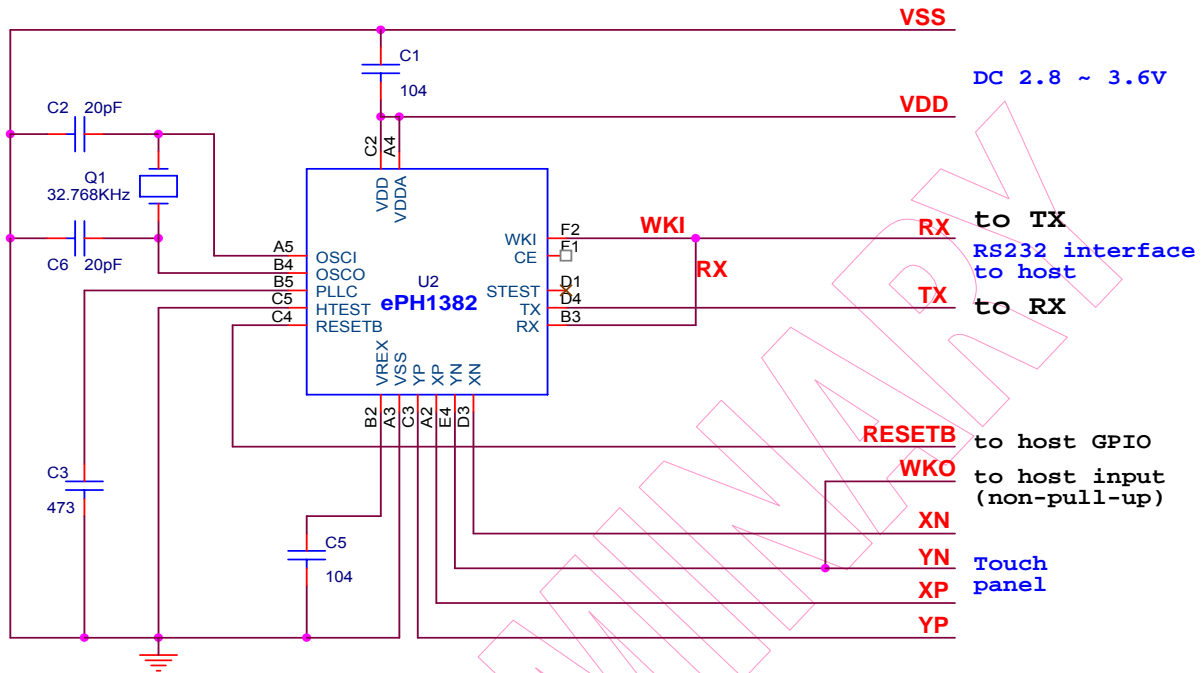

Figure 10-1 UART Interface Application Circuit (with Crystal)

#### • BOM Table

Component	Component P/N	Pin Location	Packaging	Qty
MCU	ePH1382	U2	CSP	1
Oscillator	32768 Hz Crystal	Q1	D	1
Capacitor	20pF	C2, C6	S	2
Capacitor	0.1 $\mu$ F (104)	C1, C5	S	2
Capacitor	0.047 $\mu$ F (473)	C3	S	1

## 10.2 UART Interface Application Circuit (with 32.768kHz External Clock)

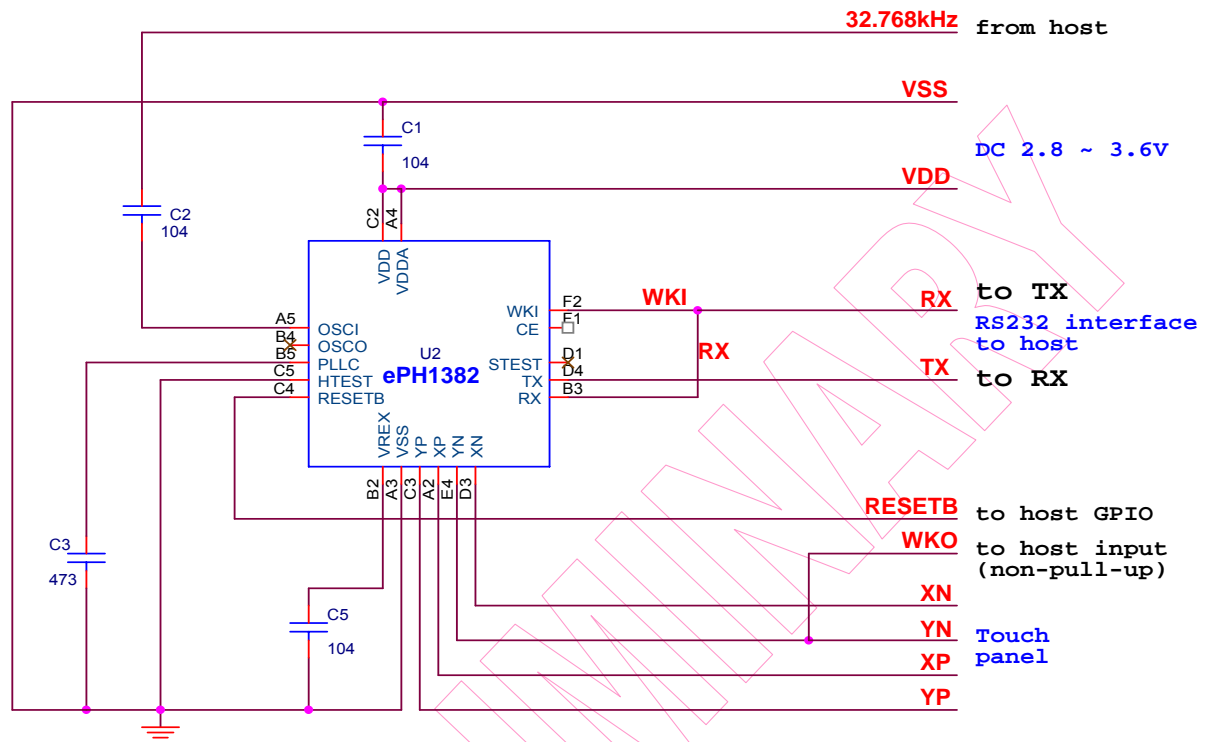
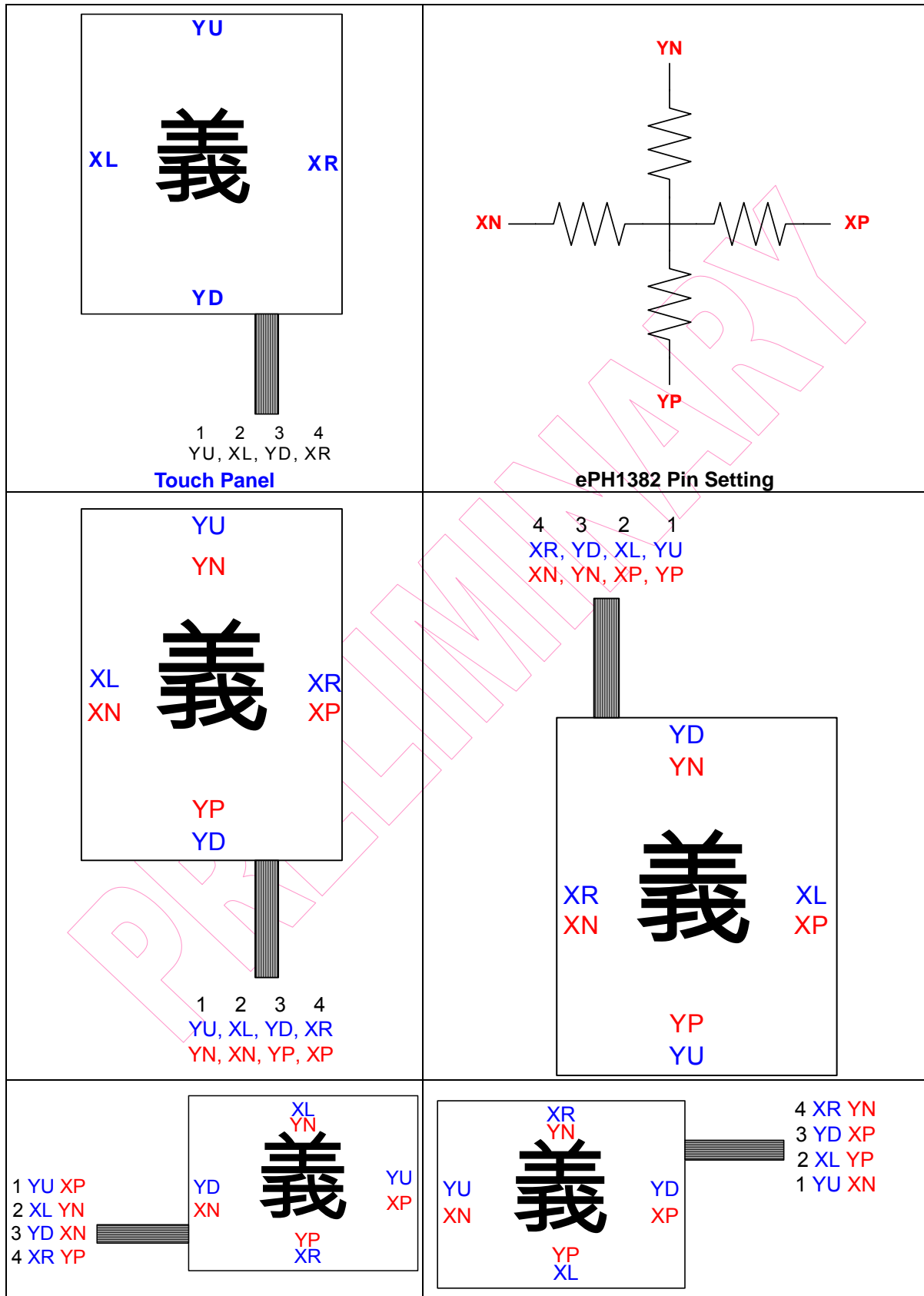

Figure 10-2 UART Interface Application Circuit (with External Clock)

### • BOM Table

Component	Component P/N	Pin Location	Packaging	Qty
MCU	ePH1382	U2	CSP	1
Capacitor	0.1 $\mu$ F (104)	C1, C2, C5	S	3
Capacitor	0.047 $\mu$ F (473)	C3	S	1

### 10.3 Touch Panel and YP, XP, YN, and XN Layout Format



## 11 HWRE Software Specification

### 11.1 HWRE Software Description

- The ePH1382 provides seven free-hand input recognition proficiencies; including Chinese Character Set I, Chinese Character Set II, etc.
- You can choose to access the input as you write (inking) with recognized characters feedback, or to access the recognized characters only without accessing the inking (input).
- The ePH1382 transmits both hand-written characters and hand-drawn graphics. Graphics inking are transmitted without recognition.
- The ePH1382 can only transmit data to host through a defined touch panel button area coordinates (located at a designated area of the touch panel). When you tap and drag on the panel, only the tapping is transmitted. Dragging is ignored.

### 11.2 Communication Protocol and Command List

#### 11.2.1 Communication Interface: UART

UART parameter: baud rate 9600; no parity check; 8 bits data length.

#### 11.2.2 Command Timing Request

When host sends command to the ePH1382, the time between two bytes must be less than 2.7ms. Otherwise, the ePH1382 will not accept the command and access the "ACK error" message.

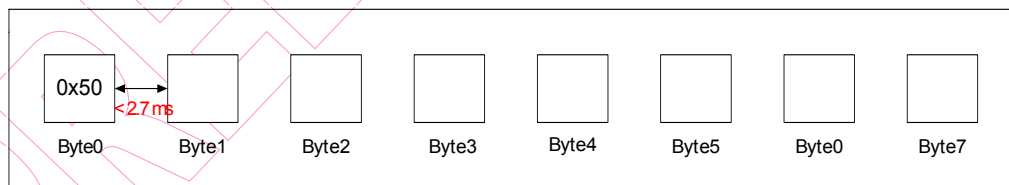

When host transmits command to the ePH1382, the time between two consecutive commands must be longer than 10 ms.

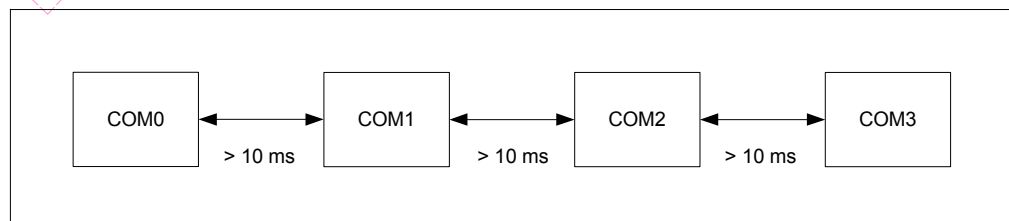

### 11.2.3 Commands from Host (see Section 11.3 for details)

Command	Brief Description	Command Response	Response at Tapping*
0x33	Wake-up the ePH1382	NA	NA
0x10	Execute the set character recognition mode	Instantaneous	Instantaneous
0x14	Execute the set inking transmit switch	Instantaneous	Instantaneous
0x1A	Execute the set pen up (next tapping) waiting time	Instantaneous	As soon as pen is up
0x1B	Recognition before timeout	Instantaneous	As soon as pen is up
0x1C	Host Ready	Instantaneous	Instantaneous
0x1D	Convert recognition and "tap to wake-up" data into even numbered package	Instantaneous	Instantaneous
0x1E	Pen up timeout offset (shorten timeout)	Instantaneous	As soon as pen is up
0x40	Get handwriting firmware version	Instantaneous	Instantaneous
0x41	Output with different code table	Instantaneous	Instantaneous
0x42	Software reset	Instantaneous	Instantaneous
0x43	Abort the current inking	Instantaneous	Instantaneous
0x44	Calibration	Instantaneous	Instantaneous
0x46	Set writing area location	Instantaneous	Instantaneous
0x49	Set Recognition / Graphic mode	Instantaneous	Instantaneous
0x4A	Set power saving mode	Instantaneous	Instantaneous
0x4C	Rotate touch panel	Instantaneous	Instantaneous
0x4D	Set stroke over waiting time	Instantaneous	Instantaneous
0x60	Single / Double writing area switch	Instantaneous	Instantaneous
0x61	Set first writing area location	Instantaneous	Instantaneous
0x62	Set second writing area location	Instantaneous	Instantaneous
0xF0	Output PROM/DROM checksum	Instantaneous	Instantaneous

- \* 1. Shows which command takes effect immediately when the host sends command to ePH1382 with the pen tapped and held on the touch panel.
2. If there is inadequate time to receive the host command, ePH1382 will initially access the "ACK error" message and wait for the host to send the correct command within 1.5 sec. After receiving a valid command or 1.5 sec timeout, ePH1382 continues to execute the original program.

### 11.2.4 Responses from ePH1382 (see Section 11.4 for details)

Command	Description
0x00	Ack error
0x16	Inking (written input) coordinates
0x17	Touch panel button area coordinates
0x18	Recognized characters array
0x33	Exit from power saving mode
0x42	Initial Power On
Host command dependent	Ack OK

## 11.3 Commands from Host Specifications

### 11.3.1 Wake up ePH1382 (0x33; 8 Bytes)

Bytes	Function	Length	Data Format	Remarks
0	Header	1	HEX	0x50
1	Command	1	HEX	0x33
2	Parameter length	1	HEX	0x04
3-6	Stuff	4	HEX	0x00; 0x00; 0x00; 0x00
7	Checksum	1	HEX	0xC7

**Description:** Host can use this command to wake up the ePH1382.

Note that this command is applicable only when the ePH1382 is in idle mode, it cannot acknowledge any response when in Fast mode.

**Example:**

Command / Response	Host	ePH1382
Command wakeup	50 33 04 00 00 00 00 C7	–
Command wake-up response	–	50 33 04 FF FF FF FF 19

### 11.3.2 Set Character Recognition Mode (0x10; 8 Bytes)

Bytes	Function	Length	Data Format	Remarks
0	Header	1	HEX	0x50
1	Command	1	HEX	0x10
2	Parameter length	1	HEX	0x04
3-4	Parameter	2	HEX	User defined
5-6	Stuff	2	HEX	0xFF; 0xFF
7	Checksum	1	HEX	–

**Description:** Set recognition type;

**Recognition Type Definition:** Total of 16 bits; (Default value: 0xFD17)

■ **Byte 3**

Bit No.	Recognition Type Description	Recognition Type Setting
0	Chinese type	0x0100
1	Not defined	0x0200
2	Set capital letter	0x0400
3	Set numeral	0x0800
4	Set symbol	0x1000
5	Set default gesture	0x2000
6	Set hiragana	0x0040
7	Set katakana	0x0080

■ **Byte 4**

Bit No.	Recognition Type Description	Recognition Type Setting
0	Set small letter	0x0001
1	PyingIn capital TYPE	0x0002
2	PyingIn small TYPE	0x0004
3	Not define	0x0008
4	Set Hangul	0x0010
5~7	Not define	0x0040

**Stroke (Gesture) Definition:**

Default Stroke Description	Default Stroke Setting
BackSpace	0x0008
Return/Enter	0x000D
Delete	0x0010
Space	0x0020

The following graphs show the default writing stroke. Dot on each stroke shows where to begin. Then lift the pen (stylus) at the end of the stroke. You only need to lightly tap and drag on the touch panel.

Backspace (0x0008) 

Return/Enter (0x000D) 

Delete (0x0010) 

Space (0x0020) 

Figure 11-1 Default Writing Strokes

Example:

Command / Response	Host	ePH1382
COM (set recognition type)	50 10 04 FF 01 FF FF 19	–
ACK (set recognition type)	–	50 10 04 FF FF FF FF 59

### 11.3.3 Set Inking Transmit Switch (0x14; 8 Bytes)

Bytes	Function	Length	Data Format	Remarks
0	Header	1	HEX	0x50
1	Command	1	HEX	0x14
2	Parameter length	1	HEX	0x04
3	User defined	1	HEX	On :0x01/Off: 0x00
4-6	Stuff	3	HEX	0xFF; 0xFF; 0xFF
7	Checksum	1	HEX	–

**Description:** Select whether to transmit or not the inking (written input). Default is to transmit (ON). During Graphic mode, inking transmit switch OFF command is ignored, but is carried out once you enter Recognition mode.

Examples:

1. Transmit inking coordinates (0x14)

Command / Response	Host	ePH1382
COM (Set inking transmit)	50 14 04 01 FF FF FF 3A	–
ACK (Set inking transmit)	–	50 14 04 FF FF FF FF FD

2. Do not transmit inking coordinates (0x14)

Command / Response	Host	ePH1382
COM (Do not transmit inking)	50 14 04 00 FF FF FF 2C	–
ACK (Do not transmit inking)	–	50 14 04 FF FF FF FF FD

### 11.3.4 Set Pen-up (Lifting of Stylus) Waiting Time (0x1A; 8 Bytes)

Bytes	Function	Length	Data Format	Remarks
0	Header	1	HEX	0x50
1	Command	1	HEX	0x1A
2	Parameter length	1	HEX	0x04
3	User defined	1	HEX	–
4-6	Stuff	3	HEX	0xFF; 0xFF; 0xFF
7	Checksum	1	HEX	

**Description:** Set pen up (lifting of stylus) waiting time.

**Pen-up Waiting Time Setting:**

1. The ePH1382 divides the pen-up time into 10 steps. 1~10 are valid values, other values represent infinite waiting. Default is 600 ms.
2. Every step increases by an increment of about 200ms. 1 represents 1x200 ms, and 10 represent 10x200 ms. If infinite pen-up time is used, the ePH1382 must initially receive the “Recognizing immediately (0x1B)” command before executing character recognition.

**Example:**

Command / Response	Host	ePH1382
COM (set pen up waiting time)	50 1A 04 03 FF FF FF AF	-
ACK (set pen up waiting time)	-	50 1A 04 FF FF FF FF 44

**11.3.5 Immediately Perform Recognition before Time out (0x1B; 8 Bytes)**

Bytes	Function	Length	Data Format	Remarks
0	Header	1	HEX	0x50
1	Command	1	HEX	0x1B
2	Parameter length	1	HEX	0x04
3-6	Stuff	4	HEX	0xFF; 0xFF; 0xFF; 0xFF
7	Checksum	1	HEX	0x6D

**Description:** Proceed to character recognition immediately.

**Example:**

Command / Response	Host	ePH1382
COM (recognize immediately)	50 1B 04 FF FF FF FF 6D	-
ACK (cannot recognize immediately)	-	50 1B 04 00 00 00 00 B3
ACK (can Recognize immediately)	-	50 1B 04 FF FF FF FF 6D

**11.3.6 Host Ready (0x1C; 8 Bytes)**

Bytes	Function	Length	Data Format	Remarks
0	Header	1	HEX	0x50
1	Command	1	HEX	0x1C
2	Parameter length	1	HEX	0x04
3-6	Stuff	4	HEX	0xFF; 0xFF; 0xFF; 0xFF
7	Checksum	1	HEX	0xB2

**Description:** With this command, the host notifies the ePH1382, “I am ready.” You can then start transmitting data after wake-up occurs (by tapping the touchpad).

**Example:** Same as Section 11.4.5, *Exit from Power Saving Mode*.



### 11.3.7 Set Even Numbered Package for Recognizing Characters and to Trigger Wake-up by Tapping the Touchpad (0x1D; 8 Bytes)

Bytes	Function	Length	Data Format	Remarks
0	Header	1	HEX	0x50
1	Command	1	HEX	0x1D
2	Parameter length	1	HEX	0x04
3	User defined	1	HEX	OFF:0x00/ON:0x01
4-6	Stuff	3	HEX	0xFF; 0xFF; 0xFF
7	Checksum	1	HEX	-

**Description:** This command defines the data format (even numbered) for recognizing characters and responding to touchpad tapping to wake-up ePH1382 (Add 0x00).

**Example:**

Command / Response	Host	ePH1382
COM (even package)	50 1D 04 01 FF FF FF 5C	-
ACK (even package)	-	50 1D 04 FF FF FF FF 9B

### 11.3.8 Pen-up (Lifting of Stylus) Time-out Offset (0x1E; 8 Bytes)

Bytes	Function	Length	Data Format	Remarks
0	Header	1	HEX	0x50
1	Command	1	HEX	0x1E
2	Parameter length	1	HEX	0x04
3	User defined	1	HEX	ON:0x01/OFF:0x00
4-6	Stuff	3	HEX	0xFF; 0xFF; 0xFF
7	Checksum	1	HEX	-

**Description:** This command subtracts 100 ms from the original setup pen up time.

**Examples:**

■ Original Pen up time = 200 ms

Command / Response	Host	ePH1382
COM (Pen up time 200 ms)	50 1A 04 01 FF FF FF 83	-
ACK(Pen up time 200 ms)	50 1A 04 FF FF FF FF 44	-
COM (Pen up timeout offset)	50 1E 04 01 FF FF FF 27	-
ACK (Pen up timeout offset) 200-100 = 100 ms	-	50 1E 04 FF FF FF FF E0

■ Original Pen up time = 400ms

Command / Response	Host	ePH1382
COM (Pen up time 400 ms)	50 1A 04 02 FF FF FF B9	-
ACK (Pen up time 400 ms)	50 1A 04 FF FF FF FF 44	-
COM (Pen up timeout offset)	50 1E 04 01 FF FF FF 27	-
ACK (Pen up timeout offset) 400-100=300 ms	-	50 1E 04 FF FF FF FF E0

### 11.3.9 Access the HWRE Firmware Version (0x40; 8 Bytes)

Bytes	Function	Length	Data Format	Remarks
0	Header	1	HEX	0x50
1	Command	1	HEX	0x40
2	Parameter length	1	HEX	0x04
3-6	Stuff	4	HEX	0xFF; 0xFF; 0xFF; 0xFF
7	Checksum	1	HEX	0xB1

**Description:** Access the Handwriting Recognition firmware version.

**Example:**

Command / Response	Host	ePH1382
COM (access firmware version)	50 40 04 FF FF FF FF B1	-
ACK (access firmware version)	-	50 40 04 03 00 75 28 6E <div style="text-align: center;"> <span style="border-bottom: 1px solid black; width: 1em; display: inline-block;"></span> <span style="border-bottom: 1px solid black; width: 1em; display: inline-block;"></span> <span style="border-bottom: 1px solid black; width: 1em; display: inline-block;"></span> <span style="border-bottom: 1px solid black; width: 1em; display: inline-block;"></span> </div> (V3.0 : 2007/05/28)

### 11.3.10 Output with Different Code Table (0x41; 8 Bytes)

Bytes	Function	Length	Data Format	Remarks
0	Header	1	HEX	0x50
1	Command	1	HEX	0x41
2	Parameter length	1	HEX	0x04
3	User defined	1	HEX	0x00: Korean / Japanese / Simplified combo 0x01: Korean only 0x02: Japanese only 0x03: Simplified Chinese only
4-6	Stuff	3	HEX	0xFF; 0xFF; 0xFF
7	Checksum	1	HEX	

**Description:** ePH1382 offers four code tables for selection. 0~3 are valid values. Any other invalid values are regarded as default value "0." The difference between the three code tables are as listed below.

- "0" : Default code table; Korean / Japanese / Simplified Chinese combo
- "1" : Korean only
- "2" : Japanese only
- "3" : Simplified Chinese only



Example:

Command / Response	Host	ePH1100
COM (output with different code table)	50 41 04 02 FF FF FF 65	-
ACK (output with different code table)	-	50 41 04 FF FF FF FF 98

### 11.3.11 Software Reset (0x42; 8 Bytes)

Bytes	Function	Length	Data Format	Remarks
0	Header	1	HEX	0x50
1	Command	1	HEX	0x42
2	Parameter length	1	HEX	0x04
3-6	Stuff	4	HEX	0xFF; 0xFF; 0xFF; 0xFF
7	Checksum	1	HEX	0xE3

**Description:** Host can use this command to reset the ePH1382. The ePH1382 will reset to initial power on when this command is executed and all settings will return to its default values.

Example:

Command / Response	Host	ePH1382
COM (software reset)	50 42 04 FF FF FF FF E3	-
ACK (software reset)	-	50 42 04 FF FF FF FF E3
COM (initial power on)	-	50 42 04 00 00 00 00 3D

### 11.3.12 Abort the Current Inking (0x43; 8 Bytes)

Bytes	Function	Length	Data Format	Remarks
0	Header	1	HEX	0x50
1	Command	1	HEX	0x43
2	Parameter length	1	HEX	0x04
3-6	Stuff	4	HEX	0xFF; 0xFF; 0xFF; 0xFF
7	Checksum	1	HEX	0xCA

**Description:** Clear the current inking.

Example:

Command / Response	Host	ePH1382
COM (clear current inking)	50 43 04 FF FF FF FF CA	-
ACK (clear current inking)	-	50 43 04 FF FF FF FF CA

### 11.3.13 Calibration (0x44; 8 Bytes)

Bytes	Function	Length	Data Format	Remarks
0	Header	1	HEX	0x50
1	Command	1	HEX	0x44
2	Parameter length	1	HEX	0x04
3-6	Stuff	4	HEX	0xFF; 0xFF; 0xFF; 0xFF;
7	Checksum	1	HEX	0x15

**Description:** Use this command to demand for ePH1382 calibration. However, the ePH1382 cannot determine whether the executed calibration command is successful or not. The host should accommodate this function.

**Example:**

Command / Response	Host	ePH1382
COM (calibration)	50 44 04 FF FF FF FF 15	–
ACK (calibration)	–	50 44 04 FF FF FF FF 15
COM (calibrate: top- left)	–	50 44 04 25 36 FF FF F3
COM (calibrate: bottom- right)	–	50 44 04 FF FF D7 CE 84

### 11.3.14 Set Writing Area Location (0x46; 8 Bytes)

Bytes	Function	Length	Data Format	Remarks
0	Header	1	HEX	0x50
1	Command	1	HEX	0x46
2	Parameter length	1	HEX	0x04
3	Top-left X coordinate	1	HEX	0x00—0xFE
4	Top-left Y coordinate	1	HEX	0x00—0xFE
5	Bottom-right X coordinate	1	HEX	0x00—0xFE
6	Bottom-right Y coordinate	1	HEX	0x00—0xFE
7	Checksum	1	HEX	–

**Description:** Set the desired location of the writing area.

**Example:**

Command / Response	Host	ePH1382
COM (set writing area location)	50 46 04 10 10 F0 F0 96	–
ACK (set writing area location)	–	50 46 04 FF FF FF FF 47

### 11.3.15 Set Recognition Mode/Graphic Mode (0x49; 8 Bytes)

Bytes	Function	Length	Data Format	Remarks
0	Header	1	HEX	0x50
1	Command	1	HEX	0x49
2	Parameter length	1	HEX	0x04
3	User defined	1	HEX	Recognition: 0x00 / Graphic: 0x01
4-6	Stuff	3	HEX	0xFF; 0xFF; 0xFF
7	Checksum	1	HEX	-

**Description:** Default is Recognition mode. Graphic mode transmission coordinates are similar to Recognition mode except recognition is not processed under Graphic mode.

**Examples:**

■ **Recognition Mode:**

Command / Response	Host	ePH1382
COM (set recognition mode)	50 49 04 00 FF FF FF 06	-
ACK (set recognition mode)	-	50 49 04 FF FF FF FF D7

■ **Graphic Mode (0x49):**

Command / Response	Host	ePH1382
COM (set Graphic Mode)	50 49 04 01 FF FF FF 10	-
ACK (set Graphic Mode)	-	50 49 04 FF FF FF FF D7

### 11.3.16 Set Power Saving Mode (0x4A; 8 Bytes)

Bytes	Function	Length	Data Format	Remarks
0	Header	1	HEX	0x50
1	Command	1	HEX	0x4A
2	Parameter length	1	HEX	0x04
3	User defined	1	HEX	Enable "Tap to wake-up": 0x01 Disable "Tap to wake-up": 0x00
4	User defined	1	HEX	Idle time for idle mode to take effect: 1~20
5-6	Stuff	2	HEX	0xFF; 0xFF
7	Checksum	1	HEX	-

**Description:**

- Byte 3 represents the tap to wake-up switch  
0x01 → Enable "Tap to wake-up" function  
0x00 → Disable "Tap to wake-up" function

2. Byte 4 represents the idle (no input) time before power saving mode takes effect. The ePH1382 divides the time into 20 steps; i.e., 1~20 (valid values). Any other value above 20 is considered as "20." Every step increases by about 15 seconds. "1" represents 1x15 seconds and 20 represent 20x15 seconds. "0" value (default) is used to prevent the ePH1382 from entering into power saving mode.
3. To instantly enter into power saving mode, add "0x80" to the defined idle time. Note that the instant power saving mode works only once and the defined idle time takes over.

**Example:**

Command / Response	Host	ePH1382
COM (set power saving mode)	50 4A 04 01 02 FF FF 96	-
ACK (set power saving mode)	-	50 4A 04 FF FF FF FF AC

**11.3.17 Rotate Touch Panel (0x4C; 8 Bytes)**

Bytes	Function	Length	Data Format	Remarks
0	Header	1	HEX	0x50
1	Command	1	HEX	0x4C
2	Parameter length	1	HEX	0x04
3	User defined	1	HEX	-
4~6	Stuff	3	HEX	0xFF; 0xFF; 0xFF
7	Checksum	1	HEX	-

**Description:** Exchange touch panel X/Y axis.

■ **Byte 3**

Bit 7	Bit 6	Bit 5	Bit 4	Bit 3	Bit 2	Bit 1	Bit 0
0	-	-	-	0	0	0	0

Bit 6=1 represents XN/YN exchange, XP/YP exchange

Bit 5=1 represents XN/XP exchange, Y direction is fixed

Bit 4=1 represents YN/YP exchange, X direction is fixed

Bit 7, Bits 0~3 must be fixed at 0.

**Example:**

Command / Response	Host	ePH1382
COM (rotate touch panel)	50 4C 04 70 FF FF FF B9	-
ACK (rotate touch panel)	-	50 4C 04 FF FF FF FF 5A



### 11.3.18 Set Stroke Over Waiting Time (0x4D; 8 Bytes)

Bytes	Function	Length	Data Format	Remarks
0	Header	1	HEX	0x50
1	Command	1	HEX	0x4D
2	Parameter length	1	HEX	0x04
3	User defined	1	HEX	0x00 ~ 0xFF
4~6	Stuff	3	HEX	0xFF; 0xFF; 0xFF
7	Checksum	1	HEX	-

**Description:** Set stroke over waiting: 0x00~0xFF. Default value is 32 ms.

**Example:**

Command / Response	Host	ePH2610
COM (set stroke over waiting time: 32 ms)	50 4D 04 20 FF FF FF 6C	-
ACK (set stroke over waiting time)	-	50 4D 04 FF FF FF FF 73

### 11.3.19 Output PROM/DROM Checksum (0xF0; 8 Bytes)

Bytes	Function	Length	Data Format	Remarks
0	Header	1	HEX	0x50
1	Command	1	HEX	0XF0
2	Parameter length	1	HEX	0x04
3~6	Stuff	4	HEX	0xFF; 0xFF; 0xFF ; 0xFF
7	Checksum	1	HEX	0xF8

**Description:** The ePH1382 can output PROM/DROM checksum through this command.

**Example:**

Command / Response	Host	ePH1382
COM (output PROM/DROM checksum)	50 F0 04 FF FF FF FF F8	-
ACK (output PROM/DROM checksum)	-	50 F0 04 FF FF FF FF F8
PROM checksum	-	50 F0 04 06 FA 8B 6E 95 ~~~~~
DROM checksum	-	50 F0 04 43 17 97 CB C6 ~~~~~

### 11.3.20 Single / Double Writing Area Switch (0x60; 8 Bytes)

Bytes	Function	Length	Data Format	Remarks
0	Header	1	HEX	0x50
1	Command	1	HEX	0x60
2	Parameter length	1	HEX	0x04
3	User defined	1	HEX	0: single writing area Others: double writing area
4~6	Stuff	3	HEX	0xFF; 0xFF; 0xFF
7	Checksum	1	HEX	-

**Description:** Single/Double writing area switch. Default mode is Single writing area.

**Example:**

- **Set Single Writing Area**

Command / Response	Host	ePH1382
COM (Set Single writing area)	50 60 04 00 FF FF FF 5B	-
ACK (S/D writing area switch)	-	50 60 04 FF FF FF FF 8A

- **Set Double Writing Area**

Command / Response	Host	ePH1382
COM (Set Double writing area)	50 60 04 01 FF FF FF 4D	-
ACK (S/D writing area switch)	-	50 60 04 FF FF FF FF 8A

### 11.3.21 Set First/Second writing Area Location (0x61/0x62; 8 Bytes)

Bytes	Function	Length	Data Format	Remarks
0	Header	1	HEX	0x50
1	Command	1	HEX	0x61 or 0x62
2	Parameter length	1	HEX	0x04
3	Top-left X coordinate	1	HEX	0x00—0xFE
4	Top-left Y coordinate	1	HEX	0x00—0xFE
5	Bottom-right X coordinate	1	HEX	0x00—0xFE
6	Bottom-right Y coordinate	1	HEX	0x00—0xFE
7	Checksum	1	HEX	-

**Description:** Set the first / second writing area location. The two writing areas must be independent (i.e. no cross area). The default setting for first writing area is (0x00, 0x00) to (0x7F, 0xFF). The Default setting for second writing area is (0x80, 0x00) to (0xFF, 0xFF). ePH1382 will depend on the first point location to determine whether the writing area is used. Once the writing area is selected, the point coordinate outside the specific writing area will be ignored for recognition kernel.

Example:

● **First Writing Area Location Setting**

Command / Response	Host	ePH1382
COM (set first area location)	50 61 04 00 00 7F 7F 66	–
ACK (set first area location)	–	50 61 04 FF FF FF FF A3

● **Second Writing Area Location Setting**

Command / Response	Host	ePH1382
COM (set second area location)	50 62 04 7F 7F FF FF E2	–
ACK (set second area location)	–	50 62 04 FF FF FF FF D8

## 11.4 Responses from ePH1382 Specifications

### 11.4.1 ACK\_ERROR (0x00; 8 Bytes)

Bytes	Function	Length	Data format	Remark
0	Header	1	HEX	0x50
1	Command	1	HEX	0x00
2	Parameter length	1	HEX	0x04
3-6	Stuff	4	HEX	0x00;0x00;0x00;0x00;
7	Checksum	1	HEX	0x19

**Description:** If the host sends an invalid command, the ePH1382 will respond with “ACK ERROR” to host.

Example:

Command / Response	Host	ePH1382
Response (ACK error)	–	50 00 04 00 00 00 00 19

### 11.4.2 Inking (Access to Written Input) Coordinates (0x16; 6 Bytes)

Bytes	Function	Length	Data Format	Remarks
0	Header	1	HEX	0x50
1	Command	1	HEX	0x16
2	Parameter length	1	HEX	0x02
3	X coordinate	1	HEX	0x00—0xFE
4	Y coordinate	1	HEX	0x00—0xFE
5	Checksum	1	HEX	–

**Description:**

- **Normal inking:** when the stylus taps the touch panel, the coordinate is transmitted.
- **Stroke over:** when the stylus leaves the touch panel, “0xFF, 0xFF” is transmitted.
- **Word over:** when a word is completed, “0xFF, 0x00” is transmitted.

**Example:**

ePH1382 Inking Response	Description
50 16 02 60 60 ED	=>Normal inking
50 16 02 65 61 AB 50 16 02 6A 61 68 50 16 02 6F 60 2E 50 16 02 74 5F 53	
50 16 02 FF FF 1B	=>Stroke over
50 16 02 40 8D CE 50 16 02 45 8F 81 50 16 02 4A 8F 42 50 16 02 4F 8F 03 50 16 02 55 8E D1 50 16 02 5C 8E 6C 50 16 02 62 8D 4A 50 16 02 67 8D 0B 50 16 02 6F 8C A4 50 16 02 74 8B 71 50 16 02 79 8A 9F 50 16 02 7E 8A F4 50 16 02 83 89 00 50 16 02 89 89 82 50 16 02 8E 88 EE 50 16 02 93 87 7D 50 16 02 98 86 ED	
50 16 02 FF FF 1B	=>Stroke over
50 16 02 FF 00 E8	=>Word over
50 18 15 0A 8C 4E A0 4E AB 51 35 6C 09 4E 3D 00 3A 00 3B 00 69 00 21 00 F9	

#### 11.4.3 Touch Panel Button Coordinates (0x17; 6 Bytes; 0xFF is Pen-up Signal)

Bytes	Function	Length	Data Format	Remarks
0	Header	1	HEX	0x50
1	Command	1	HEX	0x17
2	Parameter length	1	HEX	0x02
3	X coordinate	1	HEX	0x00—0xFE; 0xFF
4	Y coordinate	1	HEX	0x00—0xFE; 0xFF
5	Checksum	1	HEX	—

**Description:** The default values of the touch panel writing area are (0x10, 0x10) and (0xF0, 0xF0). The ePH1382 will transmit coordinates through the touch panel button area (0x17) if the tapping occurs outside the writing area.

**Example:**

Command / Response	Host	ePH1382
Response (touch panel button)	—	50 17 02 01 01 3B

#### 11.4.4 Recognized Characters Array (0x18; Maximum 25 Bytes; Minimum 6 Bytes)

Bytes	Function	Length	Data Format	Remarks
0	Header	1	HEX	0x50
1	Command	1	HEX	0x18
2	Parameter length	1	HEX	—
3	Max. qty. of characters	1	HEX	—
4	Characters (low byte)	1	HEX	—
5	Characters (high byte)	1	HEX	—
....	—	—	—	—
N	Checksum	1	HEX	—

**Description:** Recognized characters array package. No character will utilize 6 bytes.

**Example:**

Command / Response	Host	ePH1382
Response (characters)	–	50 18 03 01 08 00 3A

#### 11.4.5 Exit from Power Saving Mode (0x33; 8 Bytes)

Bytes	Function	Length	Data Format	Remarks
0	Header	1	HEX	0x50
1	Command	1	HEX	0x33
2	Parameter length	1	HEX	0x04
3-6	Stuff	4	HEX	0xFF; 0xFF; 0xFF; 0xFF
7	Checksum	1	HEX	0x19

**Description:**

##### ■ Wake-up Conditions

When the ePH1382 enters power saving mode, it will wake-up when one of the following conditions occurs:

##### 1. Touch panel wake-up (“tap to wake-up”):

Tap the touch panel and the ePH1382 wakes-up and sends 1 byte (0x00) to host. Host must respond “Host ready” within 7.5 sec, else the ePH1382 will enter power saving mode again. Note that ePH1382 must have the tap-to-wake-up function enabled in order to perform this function.

**Example:**

Command / Response	Host	ePH1382
Touch panel wake-up response	–	00
Com (Host ready)	50 1C 04 FF FF FF FF B2	–
ACK (Host ready)	–	50 1C 04 FF FF FF FF B2
Response	–	50 33 04 FF FF FF FF 19

##### 2. Command wake-up:

Host executes command “50 33 04 00 00 00 00 C7” to wake-up the ePH1382.

**Example:**

Command / Response	Host	ePH1382
Command wakeup	50 33 04 00 00 00 00 C7	–
Command wakeup response	–	50 33 04 FF FF FF FF 19

■ ePH1382 Wake-up Response Signal Details

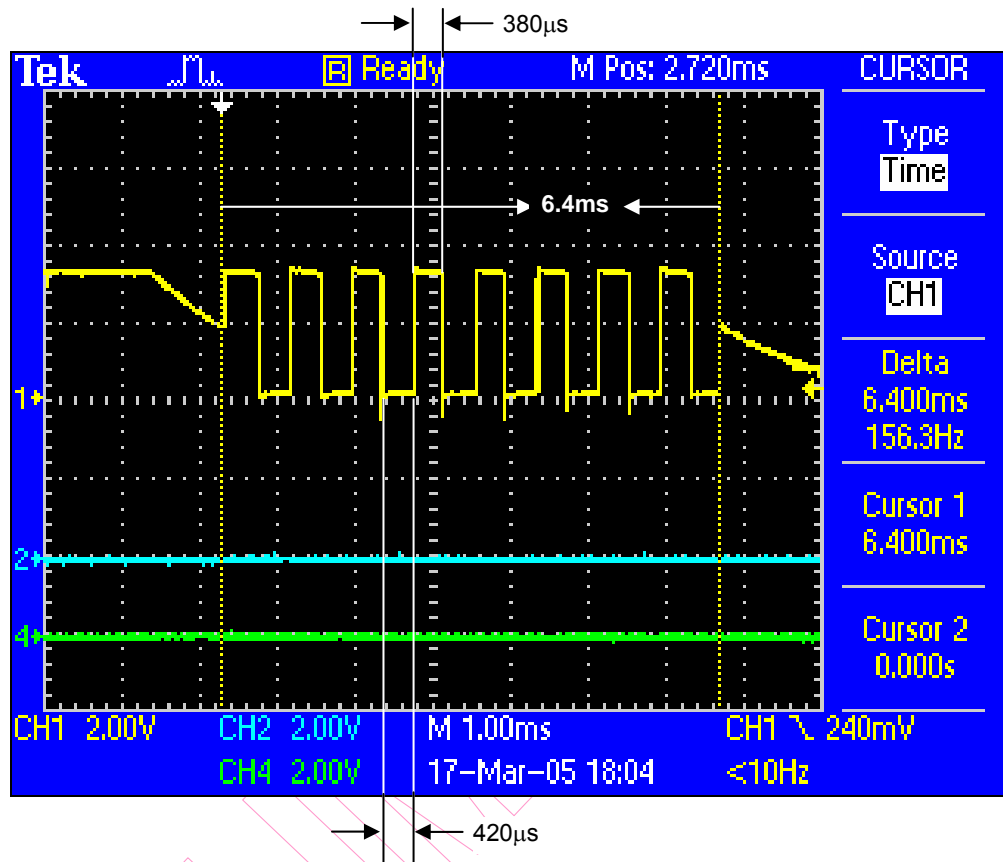

Figure 11-2 ePH1382 to Host Signal Waveform after Wake-up from Idle Mode

The above waveform illustrates the characteristics of the signal which ePH1382 sends to host after it wakes up from Idle mode. This signal is composed of 8 clocks with total width of 6.4ms and is applicable only under “Tap to wakeup” condition.

**11.4.6 Initial Power-on (0x42; 8 Bytes)**

Bytes	Function	Length	Data Format	Remarks
0	Header	1	HEX	0x50
1	Command	1	HEX	0x42
2	Parameter length	1	HEX	0x04
3-6	Stuff	4	HEX	0x00; 0x00; 0x00; 0x00;
7	Checksum	1	HEX	0x3D

**Description:** When the ePH1382 is powered on, it will send “Initial power-on” response to host.

**Example:**

Command / Response	Host	ePH1382
Response (initial power on)	–	50 42 04 00 00 00 00 3D

### 11.4.7 ACK\_OK (Carry Out Host Command; 8 Bytes)

Bytes	Function	Length	Data format	Remark
0	Header	1	HEX	0x50
1	Follow host command	1	HEX	-
2	Parameter length	1	HEX	0x04
3-6	Stuff	4	HEX	0xFF, 0xFF, 0xFF, 0xFF
7	Checksum	1	HEX	-

**Description:** After executing the host command, ePH1382 responds with an “ACK OK” format which corresponds to the given command.

**Example:** Refer to each command sample provided in this specification.

## 11.5 Checksum Program

**Reference :** [www.6502.org](http://www.6502.org):

**Source:** CRC Calculations

```
CRC-8 8bits checksum table
const BYTE CRCTable[256]={
0x00,0x07,0x0E,0x09,0x1C,0x1B,0x12,0x15,0x38,0x3F,0x36,0x31,
0x24,0x23,0x2A,0x2D,0x70,0x77,0x7E,0x79,0x6C,0x6B,0x62,0x65,
0x48,0x4F,0x46,0x41,0x54,0x53,0x5A,0x5D,0xE0,0xE7,0xEE,0xE9,
0xFC,0xFB,0xF2,0xF5,0xD8,0xDF,0xD6,0xD1,0xC4,0xC3,0xCA,0xCD,
0x90,0x97,0x9E,0x99,0x8C,0x8B,0x82,0x85,0xA8,0xAF,0xA6,0xA1,
0xB4,0xB3,0xBA,0xBD,0xC7,0xC0,0xC9,0xCE,0xDB,0xDC,0xD5,0xD2,
0xFF,0xF8,0xF1,0xF6,0xE3,0xE4,0xED,0xEA,0xB7,0xB0,0xB9,0xBE,
0xAB,0xAC,0xA5,0xA2,0x8F,0x88,0x81,0x86,0x93,0x94,0x9D,0x9A,
0x27,0x20,0x29,0x2E,0x3B,0x3C,0x35,0x32,0x1F,0x18,0x11,0x16,
0x03,0x04,0x0D,0x0A,0x57,0x50,0x59,0x5E,0x4B,0x4C,0x45,0x42,
0x6F,0x68,0x61,0x66,0x73,0x74,0x7D,0x7A,0x89,0x8E,0x87,0x80,
0x95,0x92,0x9B,0x9C,0xB1,0xB6,0xBF,0xB8,0xAD,0xAA,0xA3,0xA4,
0xF9,0xFE,0xF7,0xF0,0xE5,0xE2,0xEB,0xEC,0xC1,0xC6,0xCF,0xC8,
0xDD,0xDA,0xD3,0xD4,0x69,0x6E,0x67,0x60,0x75,0x72,0x7B,0x7C,
0x51,0x56,0x5F,0x58,0x4D,0x4A,0x43,0x44,0x19,0x1E,0x17,0x10,
0x05,0x02,0x0B,0x0C,0x21,0x26,0x2F,0x28,0x3D,0x3A,0x33,0x34,
0x4E,0x49,0x40,0x47,0x52,0x55,0x5C,0x5B,0x76,0x71,0x78,0x7F,
0x6A,0x6D,0x64,0x63,0x3E,0x39,0x30,0x37,0x22,0x25,0x2C,0x2B,
0x06,0x01,0x08,0x0F,0x1A,0x1D,0x14,0x13,0xAE,0xA9,0xA0,0xA7,
0xB2,0xB5,0xBC,0xBB,0x96,0x91,0x98,0x9F,0x8A,0x8D,0x84,0x83,
0xDE,0xD9,0xD0,0xD7,0xC2,0xC5,0xCC,0xCB,0xE6,0xE1,0xE8,0xEF,
0xFA,0xFD,0xF4,0xF3};
```

Code of producing and verifying checksum :

```
unsigned char GenerateCRC(unsigned char *Packet,
int size)
{
int i;
unsigned char value;
value=0;
for(i=0;i<size-1;i++){
value ^= Packet[i];
value=CRCTable[value];
}
return value;
}

void main(void)
{
unsigned char Packet[8]; //produce checksum of 8bytes package
int I;
for(I=0;I<8;I++)Packet[I]=0;
Packet[7]=GenerateCRC(Packet,sizeof(Packet)) //checksum place the eighth
byte }
```

## 12 Package Outline Drawing

- LQFP44

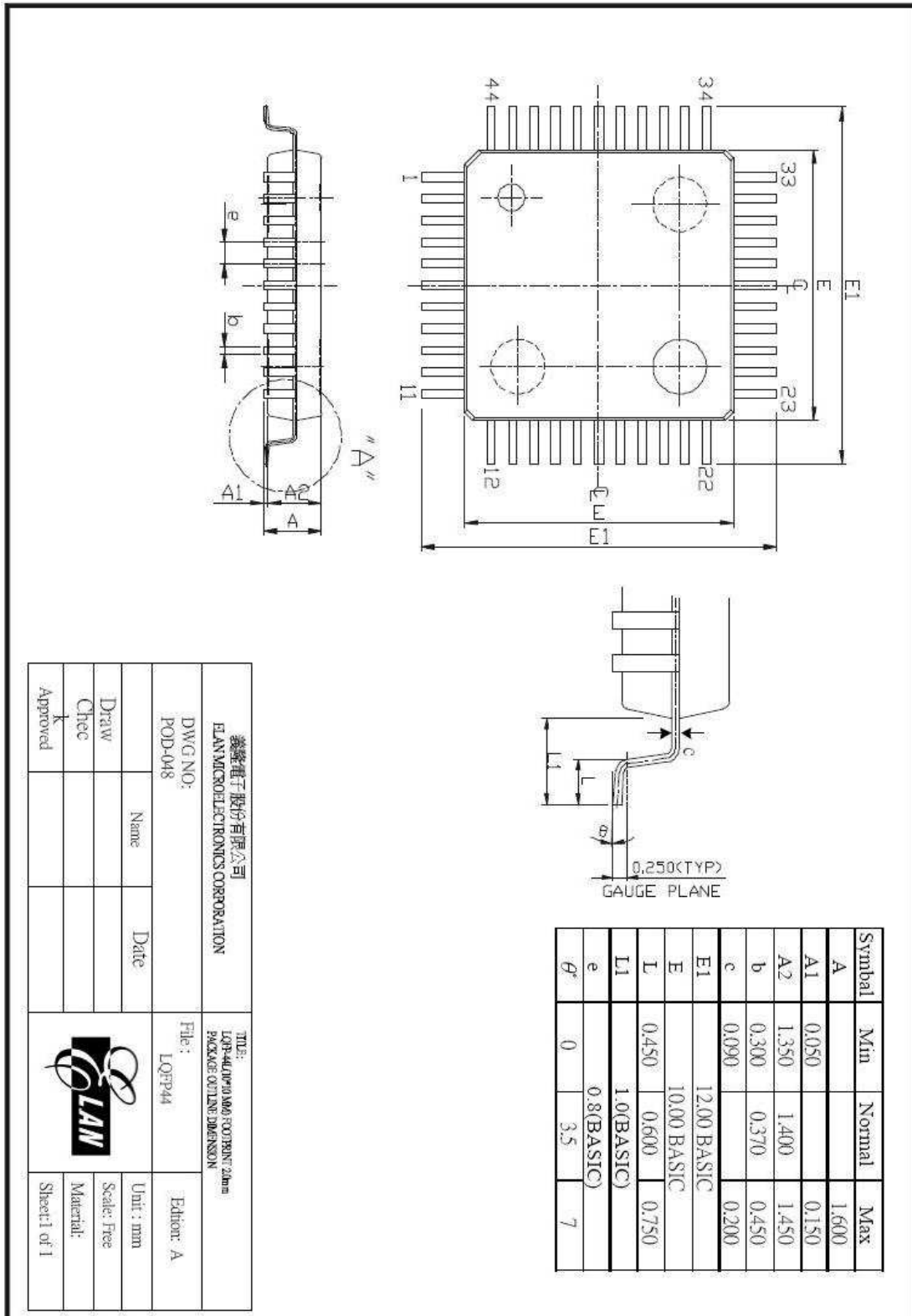

### 13 Tape Reel Specification

