ePH1100

**Handwriting
Recognition
Microcontroller**

**Product
Specification**

DOC. VERSION 2.4

ELAN MICROELECTRONICS CORP.

February 2006



Trademark Acknowledgments:**IBM is a registered trademark and PS/2 is a trademark of IBM****Windows is a trademark of Microsoft Corporation****ELAN and ELAN logo  are trademarks of ELAN Microelectronics Corporation****Copyright © 2006 by ELAN Microelectronics Corporation****All Rights Reserved****Printed in Taiwan**

The contents of this specification are subject to change without further notice. ELAN Microelectronics assumes no responsibility concerning the accuracy, adequacy, or completeness of this specification. ELAN Microelectronics makes no commitment to update, or to keep current the information and material contained in this specification. Such information and material may change to conform to each confirmed order.

In no event shall ELAN Microelectronics be made responsible for any claims attributed to errors, omissions, or other inaccuracies in the information or material contained in this specification. ELAN Microelectronics shall not be liable for direct, indirect, special incidental, or consequential damages arising from the use of such information or material.

The software (if any) described in this specification is furnished under a license or nondisclosure agreement, and may be used or copied only in accordance with the terms of such agreement.

ELAN Microelectronics products are not intended for use in life support appliances, devices, or systems. Use of ELAN Microelectronics product in such applications is not supported and is prohibited.

NO PART OF THIS SPECIFICATION MAY BE REPRODUCED OR TRANSMITTED IN ANY FORM OR BY ANY MEANS WITHOUT THE EXPRESSED WRITTEN PERMISSION OF ELAN MICROELECTRONICS.



ELAN MICROELECTRONICS CORPORATION

Headquarters:

No. 12, Innovation Road 1
Hsinchu Science Park
Hsinchu, Taiwan 30077
Tel: +886 3 563-9977
Fax: +886 3 563-9966
<http://www.emc.com.tw>

Hong Kong:

Elan (HK) Microelectronics Corporation, Ltd.
Rm. 1005B, 10/F Empire Centre
68 Mody Road, Tsimshatsui
Kowloon, HONG KONG
Tel: +852 2723-3376
Fax: +852 2723-7780
elanhk@emc.com.hk

USA:

Elan Information Technology Group (U.S.A.)
1821 Saratoga Ave., Suite 250
Saratoga, CA 95070
USA
Tel: +1 408 366-8225
Fax: +1 408 366-8220

Europe:

Elan Microelectronics Corp. (Europe)
Siewerdtsstrasse 105
8050 Zurich, SWITZERLAND
Tel: +41 43 299-4060
Fax: +41 43 299-4079
<http://www.elan-europe.com>

Shenzhen:

Elan Microelectronics Shenzhen, Ltd.
SSMEC Bldg., 3F, Gaoxin S. Ave.
Shenzhen Hi-Tech Industrial Park
Shenzhen, Guangdong, CHINA
Tel: +86 755 2601-0565
Fax: +86 755 2601-0500

Shanghai:

Elan Microelectronics Shanghai, Ltd.
23/Bldg. #115 Lane 572, Bibo Road
Zhangjiang Hi-Tech Park
Shanghai, CHINA
Tel: +86 21 5080-3866
Fax: +86 21 5080-4600

Contents

1	Introduction	1
2	Features	1
3	Block Diagram	1
4	Pin Assignment	2
4.1	LQFP 44 Pin	2
4.2	CSP (Chip Size Package) 24 Pin	3
4.3	Ordering Information	4
5	Pin Description	4
6	Interface Control Timing Description	5
6.1	UART Interface Control (9600, N, 8, 1)	5
7	Pin Option Description	5
8	Electrical Characteristic	6
8.1	Absolute Maximum Ratings	6
8.2	Recommended Operating Conditions	6
8.3	DC Electrical Characteristics (Condition: Ta=25°C, VDD= 3.0 ± 0.3V)	6
8.4	A/D Conversion (VDD=3.0V, VDDA=3.0V, Ta=25°C, Fclk=12*Fsample)	7
8.5	AC Electrical Characteristics (Condition: Ta=25°C, VDD=3.0 ± 0.3V)	7
9	Power-up and Reset Timing	8
10	Application Circuit	9
10.1	UART Interface Application Circuit (with 32.768kHz Crystal)	9
10.1.1	BOM Table	9
10.2	UART Interface Application Circuit (with 32.768kHz External Clock)	10
10.2.1	BOM Table	10
10.3	Touch Panel and YP, XP, YN, and XN Layout Format	11
11	HWRE Software Specification	12
11.1	HWRE Software Description	12
11.2	Communication Protocol and Command List	12
11.2.1	Communication Interface: UART	12
11.2.2	Command Timing Request	12
11.2.3	Commands from Host	13
11.2.4	Responses from ePH1100	13



11.3	Commands from Host Specifications.....	14
11.3.1	Wake-up ePH1100 (0x33; 8 Bytes).....	14
11.3.2	Set Character Recognition Mode (0x10; 8 Bytes)	14
11.3.3	Set Inking Transmit Switch (0x14; 8 Bytes)	16
11.3.4	Set Pen-up (Lifting of Stylus) Waiting Time (0x1A; 8 Bytes).....	16
11.3.5	Perform Recognition Immediately, i.e., Before Timeout (0x1B; 8 Bytes).....	17
11.3.6	Host Ready (0x1C; 8 Bytes)	17
11.3.7	Set Even Numbered Package for Recognizing Characters and to Trigger Wake-up by Tapping the Touch Pad (0x1D; 8 Bytes)	18
11.3.8	Pen-up (Lifting of Stylus) Time-out Offset (0x1E; 8 Bytes)	18
11.3.9	Access the HWRE Firmware Version (0x40; 8 Bytes).....	19
11.3.10	Output with Different Code Table (0x41; 8 Bytes).....	19
11.3.11	Software Reset (0x42; 8 Bytes)	20
11.3.12	Abort the Current Inking (0x43; 8 Bytes).....	21
11.3.13	Calibration (0x44; 8 Bytes).....	21
11.3.14	Set Writing Area Location (0x46; 8 Bytes)	22
11.3.15	Set Recognition Mode/Graphic Mode (0x49; 8 Bytes).....	22
11.3.16	Set Power Saving Mode (0x4A; 8 Bytes).....	23
11.3.17	Set A/D Resolution (0x4B; 8 Bytes)	23
11.3.18	Rotate Touch Panel (0x4C; 8 Bytes).....	24
11.4	Responses from ePH1100 Specifications.....	24
11.4.1	ACK_ERROR (0x00; 8 Bytes)	24
11.4.2	Inking (Access to Written Input) Coordinates (0x16; 6 Bytes)	25
11.4.3	Touch Panel Button Coordinates (0x17; 6 Bytes; 0xFF is Pen-up Signal)	26
11.4.4	Recognized Characters Array (0x18; Maximum 25 Bytes; Minimum 6 Bytes) 26	
11.4.5	Exit from Power Saving Mode (0x33; 8 Bytes)	27
11.4.6	Initial Power On (0x42; 8 Bytes)	29
11.4.7	ACK_OK (Carry Out Host Command; 8 Bytes)	29
11.5	Checksum Program.....	30
12	Package LQFP44	31
13	Tape Reel Specification	32

Specification Revision History

Doc. Version	Revision Description	Date
2.0	ePH1100 initial specification	2005/03/11
2.1	Added new info and waveform diagram on ePH1100 response signal	2005/03/21
2.2	Added new commands on the "A/D Resolution" & Touch Panel Rotation"	2005/06/07
2.3	Modified the Application Circuits	2005/10/14
2.4	Added accurate CSP size and modified the CSP tape reel spec.	2006/02/16



1 Introduction

The ePH1100 chip is an 8 bit RISC microcontroller embedded with recognition core. When connected to an external resistance type touch panel, the chip becomes suitable for handwriting recognition application products, such as SMS, Stylus Remote Controller, mobile phones, handwriting input device, etc. The ePH1100 has low power consumption, low cost, and yet is capable of providing high performance rate of recognition. These quality features are vital for shorter lead-time in developing new handwriting recognition related products or pressure-sensitive screen input devices.

2 Features

Product No.	Package	Input	Output	Interface	Remarks
ePH1100	CSP/ LQFP44	1. Traditional Chinese 2. Simplified Chinese 3. ASCII 4. Gesture 5. Hiragana / Katakana	Unicode	UART	What you input (Traditional or Simplified Chinese) is what you get as output. Can recognize 13,053 (Big 5) Traditional Chinese characters, and 6,763 (GB2312) Simplified Chinese characters.

3 Block Diagram

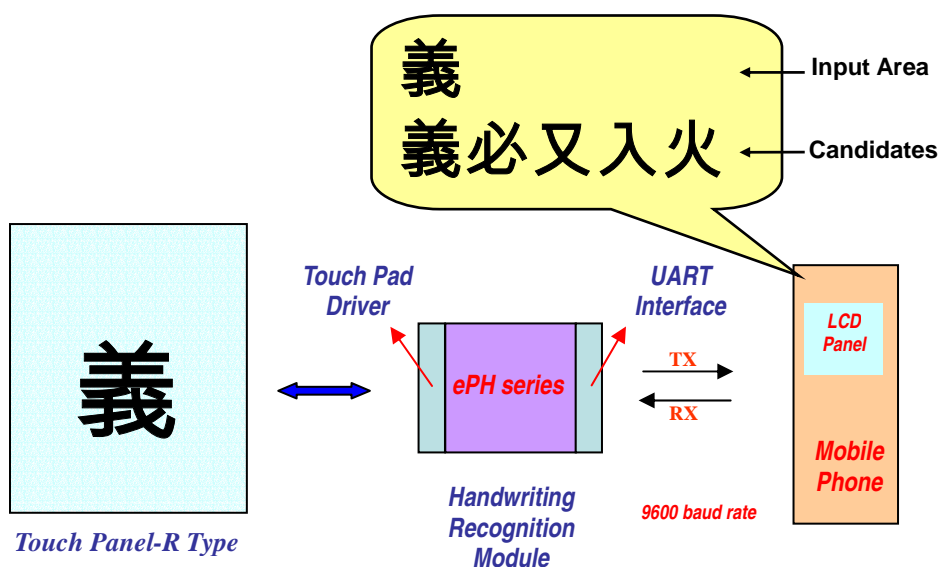

4 Pin Assignment

4.1 LQFP 44 Pin

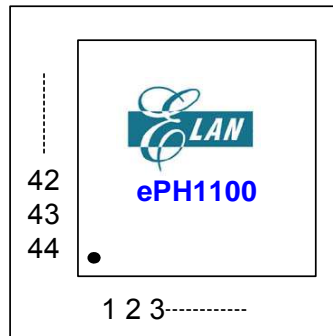

No.	Pin Name	No.	Pin Name	No.	Pin Name	No.	Pin Name
1	NC	12	YP	23	CE	34	NC
2	NC	13	XP	24	NC	35	NC
3	HTEST	14	YN (WKO)	25	NC	36	NC
4	PLLC	15	XN	26	NC	37	NC
5	OSCI	16	VREX	27	NC	38	NC
6	OSCO	17	VDD	28	NC	39	NC
7	RESETB	18	STEST	29	NC	40	NC
8	VDDA	19	NC	30	NC	41	NC
9	VSS	20	NC	31	NC	42	NC
10	TX	21	WKI	32	NC	43	NC
11	RX	22	NC	33	NC	44	NC

4.2 CSP (Chip Size Package) 24 Pin

Perspective view of the pin locations viewed from the top surface of the chip.

Accurate package size: $(4415 \pm 55) \mu\text{m} \times (3815 \pm 55) \mu\text{m}$.

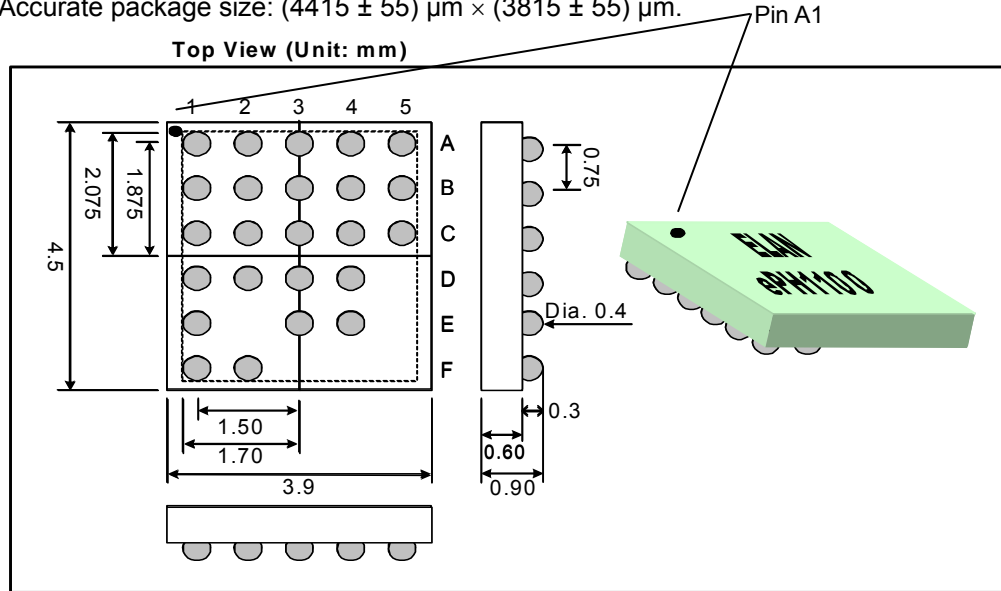

Perspective View from the Top Side						
Y Coordinate	X Coordinate	-1.500	-0.750	0.000	0.750	1.500
		1	2	3	4	5
1.875	A	NC	XP	VSS	VDDA	OSCI
1.125	B	NC	VREX	RX	OSCO	PLLC
0.375	C	NC	VDD	YP	RESETB	HTEST
-0.375	D	STEST	NC	XN	TX	-
-1.125	E	NC	-	NC	YN (WKO)	-
-1.875	F	CE	WKI	-	-	-

Pin location and assignment viewed from the actual pin (bottom) side of the chip.

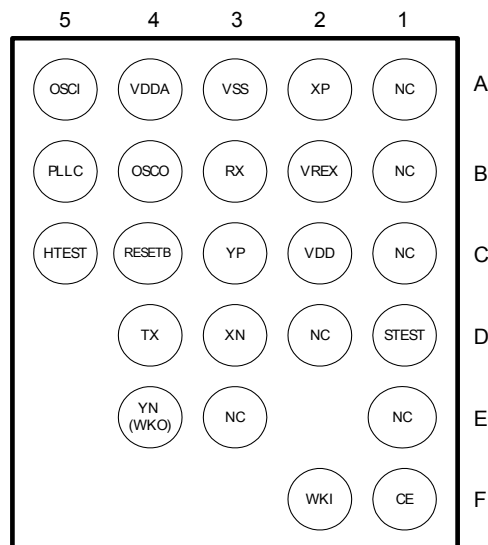

4.3 Ordering Information

Orderable Part Number	Package Type	
ePH1100SH	CSP	Tray of 72
ePH1100KSH		Tape reel of 2000
ePH1100AQ	LQFP44 10x10mm	

5 Pin Description

CSP	LQFP44	Name	I/O/P Type	Description
C2	17	VDD	P	Digital power supply, ranging from 2.8V to 3.6V. Should be connected to VSS through a 0.1µF capacitor.
A3	9	VSS	P	Negative power supply
A4	8	VDDA	P	Analog power supply, ranging from 2.8V to 3.6V. Should be connected to VSS through a 0.1µF capacitor.
C4	7	RESETB	I	System reset input pin with built-in pull up resistor (typical value = 100KΩ). Should be connected to one GPIO pin.
C5	3	HTEST	I	Hardware testing. Normally connected to VSS
A5	5	OSCI	I	Crystal or External Clock Source connector pin: <ul style="list-style-type: none"> Crystal: Connect a 32.768 kHz crystal and connect to VSS through a 20pF capacitor External Clock Source: Connect a 32.768 kHz (± 20ppm) clock signal through a 0.1µF capacitor (Clock VPP>0.3VDD)
B4	6	OSCO	O	Crystal or External Clock Source connector pin: <ul style="list-style-type: none"> Crystal: Connect a 32.768 kHz crystal and connect to VSS through a 20pF capacitor. External Clock Source: Keep the pin floating.
B5	4	PLLCC	I	PLL capacitor connector pin. Should be connected to VSS through a 0.047µF capacitor.
B2	16	VREX	I/O	Internal reference voltage for A/D converter. Should be connected to VSS through a 0.1µF capacitor.
F1	23	CE	I	“Floating”: Chip Enable. “L”: Chip power down. UART interface pin will change to High-Z status.
D1	18	STEST	I	Software testing. Normally floating or connected to VDD.
D4	10	TX	O	UART Interface Tx pin
B3	11	RX	I	UART Interface Rx pin
C3	12	YP	I	Touch screen Y direction positive pin
A2	13	XP	I	Touch screen X direction positive pin
E4	14	YN (WKO)	O	Touch screen Y direction negative pin. This pin should be connected to an input pin of the Host. Such Host input pin must be set as “non-pull-up” resistor type and provides a wake-up function.
D3	15	XN	O	Touch screen X direction negative pin
F2	21	WKI	I	Wake-up input pin. Host wakes up the ePH1100 from power saving mode through this pin.

6 Interface Control Timing Description

6.1 UART Interface Control (9600, N, 8, 1)

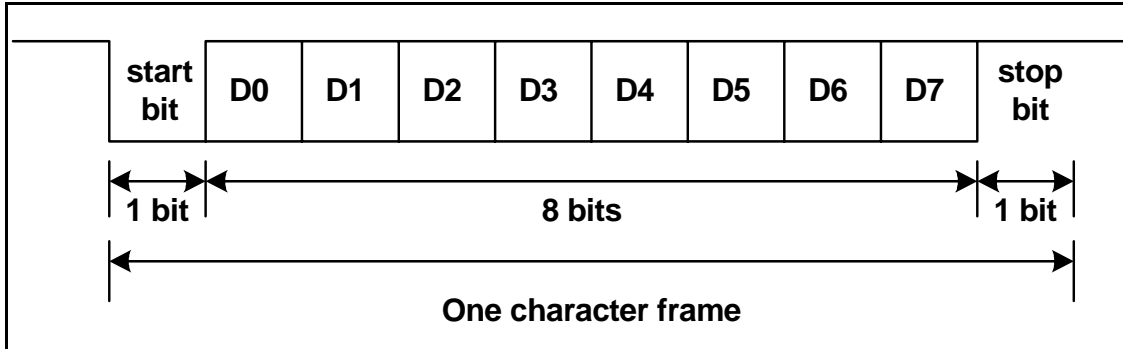

7 Pin Option Description

- CE Pin Option

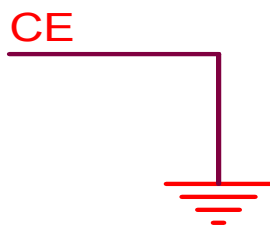

Chip Disabled



Chip Enabled

- RESETB Pin Timing

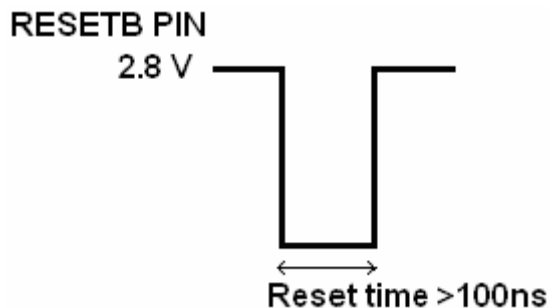

8 Electrical Characteristic

8.1 Absolute Maximum Ratings

Items	Symbol	Condition	Limits	Unit
Supply Voltage	VDD		-0.3 to +3.6	V
Input Voltage (General Input Port)	VIN		-0.5 to VDD +0.5	V
Operating Temperature Range	TOPR		-20 to +80	°C
Storage Temperature Range	TSTR		-55 to +125	°C

8.2 Recommended Operating Conditions

Items	Symbol	Condition	Limits	Unit
Supply Voltage	VDD		2.8 to 3.6	V
	VDDA		2.8 to 3.6	
Input Voltage	VIH		VDD x 0.9 to VDD	V
	VIL		0 to VDD x 0.1	V
A/D Full-Scale Input Span	ADRG	Positive input– negative input	0 to VREX	V
Operating Temperature	TOPR		-20 to +80	°C

8.3 DC Electrical Characteristics

(Condition: Ta=25° C, VDD= 3.0 ± 0.3V)

Parameter	Symbol	Condition		Min	Type	Max	Unit
CLOCK	Fmain	Main-clock frequency		–	9.83	–	MHz
	Fsub	Sub-clock frequency	X'tal OSC	–	32.768	–	KHz
Supply Current	Idd2	IDLE mode	VDD=3V, X'tal OSC.	–	5	8	μA
	Idd3	FAST mode	VDD=3V, Fmain=9.83MHz without touch panel load	–	2000	3000	
Input Voltage	VIH1	Input pin		VDD×0.7	–	VDD	V
	VIL1			0	–	VDD×0.3	
Input Threshold Voltage (Schmitt)	VT+	RESETB pin		0.5×VDD	–	0.75×VDD	V
	VT–			0.2×VDD	–	0.4×VDD	
Output Current	IOH1	Output pin	VDD=3V, VOH=2.4V	-1.1	-2.2	-3.3	mA
	IOL1		VDD=3V, VOL=0.2V	+1.1	+2.2	+3.3	
Input Leakage Current	IIL	ALL Input port (without pull up/down resistor) Vin=VDD or GND		–	–	±1	μA
Touch Panel Pull Down Resistance	RPD3	DET=1, Xn pin	Vin=VDD, VDD=3V	25	50	100	KΩ
Data Retention Voltage	Vret			1.6	–	–	V
Power on Reset Voltage	Vpor			1.4	1.5	1.6	V

8.4 A/D Conversion

(VDD=3.0V, VDDA=3.0V, Ta=25° C, Fclk=12*Fsample)

Parameter	Symbol	Condition	Min	Type	Max	Unit
Analog Input						
Mux Leakage Current	Imux	On/off leakage current, Vin=0 or VDD	-	0.1	1	μA
System Performance						
Resolution			-	10	-	Bits
Integral Non-Linearity	INL		-2	-	+2	LSB
Differential Non-linearity	DNL		-2	-	+2	LSB
Offset Error	OErr		-4	-	+4	LSB
Gain Error	GErr		-4	-	+4	LSB
Missing Code	MC					Bit
VDDA Supply Current	Ivdd3	VDD=3.0V, VDDA=3.0V, Fsample=20kHz, ADEN=1, VRS=1	-	0.5	0.7	mA
	Ivdd4	ADEN=0, VRS=1	-	-	1	uA
Driver Current	IOH	Xp,Yp (VDD= 2.9 ± 0.3V) (Voh=VDD-0.2V)	-20	-30	-45	mA
Sink Current	IOL	Xn,Yn (VDD= 2.9 ± 0.3V)(Vol=0.2V)	+20	+30	+45	mA

8.5 AC Electrical Characteristics

(Condition: Ta=25°C, VDD=3.0 ± 0.3V)

Parameter	Symbol	Condition	Min	Type	Max	Unit
A/D Conversion (VDD=3.0V, VDDA=3.0V, Ta=-10~+60°C)						
Throughput Rate		VDD=3.0V, VDDA=3.0V	-	-	80	ksp/s
		VDD=2.4V, VDDA=2.4V	-	-	60	
Power Supply Rejection Ratio	PSRR1+	Power noise: 1kHz, 100mV	37	40	-	dB
	PSRR1-	Power noise: 1kHz, 100mV	43	46	-	
Signal to Noise Ratio	SNR		51	54	-	dB

9 Power-up and Reset Timing

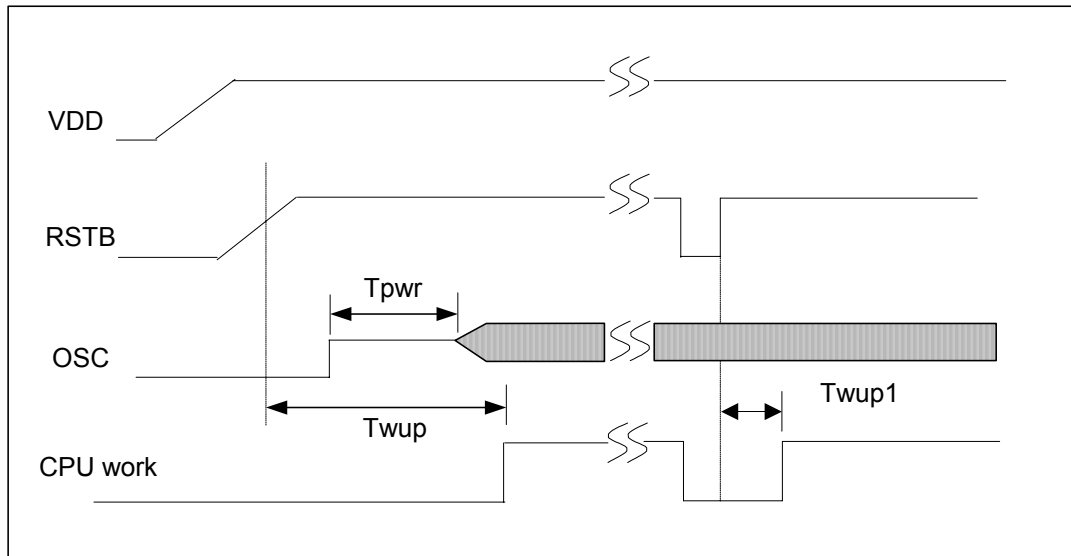

Symbol	Characteristics	Min.	Type	Max.	Unit
Tpwr	Oscillator start up time	100	226	300	ms
Twup	CPU warm up time	260	340	550	ms
Twup1	CPU reset time	18	22	44	ms

10 Application Circuit

10.1 UART Interface Application Circuit (with 32.768kHz Crystal)

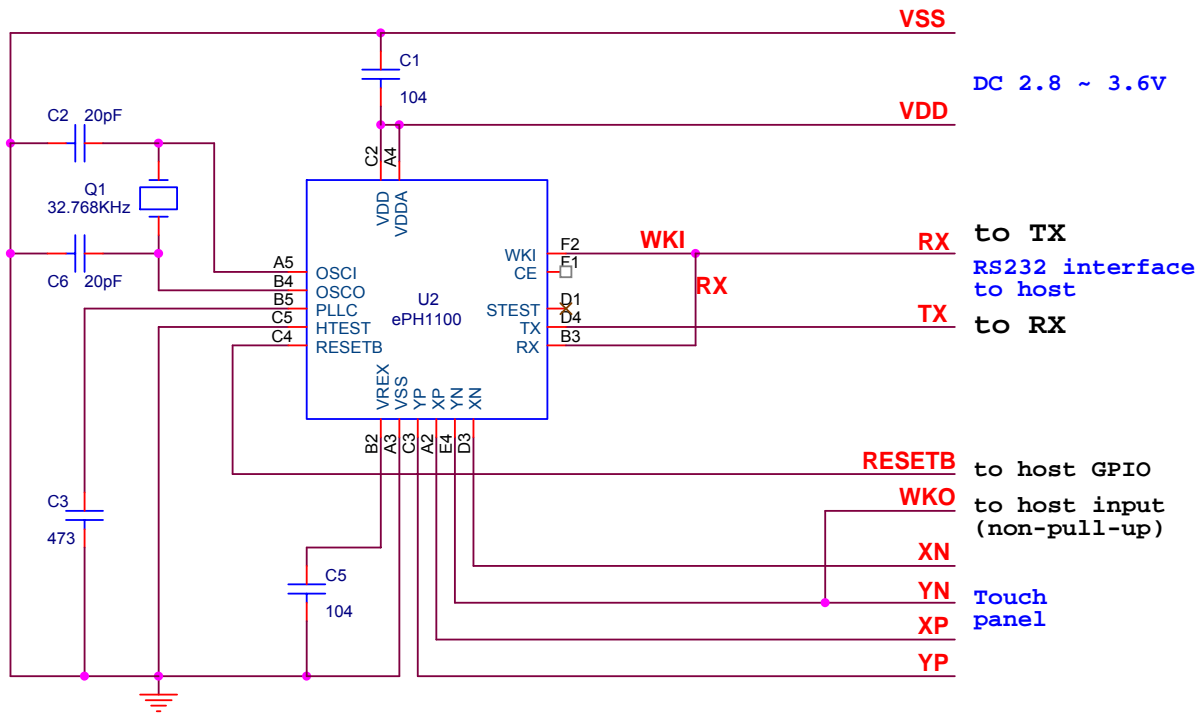

10.1.1 BOM Table

Component	Component P/N	Pin Location	Packaging	Qty
MCU	ePH1100	U2	CSP	1
Oscillator	32768HZ Crystal	Q1	D	1
Capacitor	20pF	C2, C6	S	2
Capacitor	0.1µF (104)	C1, C4, C5	S	3
Capacitor	0.047µF (473)	C3	S	1

10.2 UART Interface Application Circuit (with 32.768kHz External Clock)

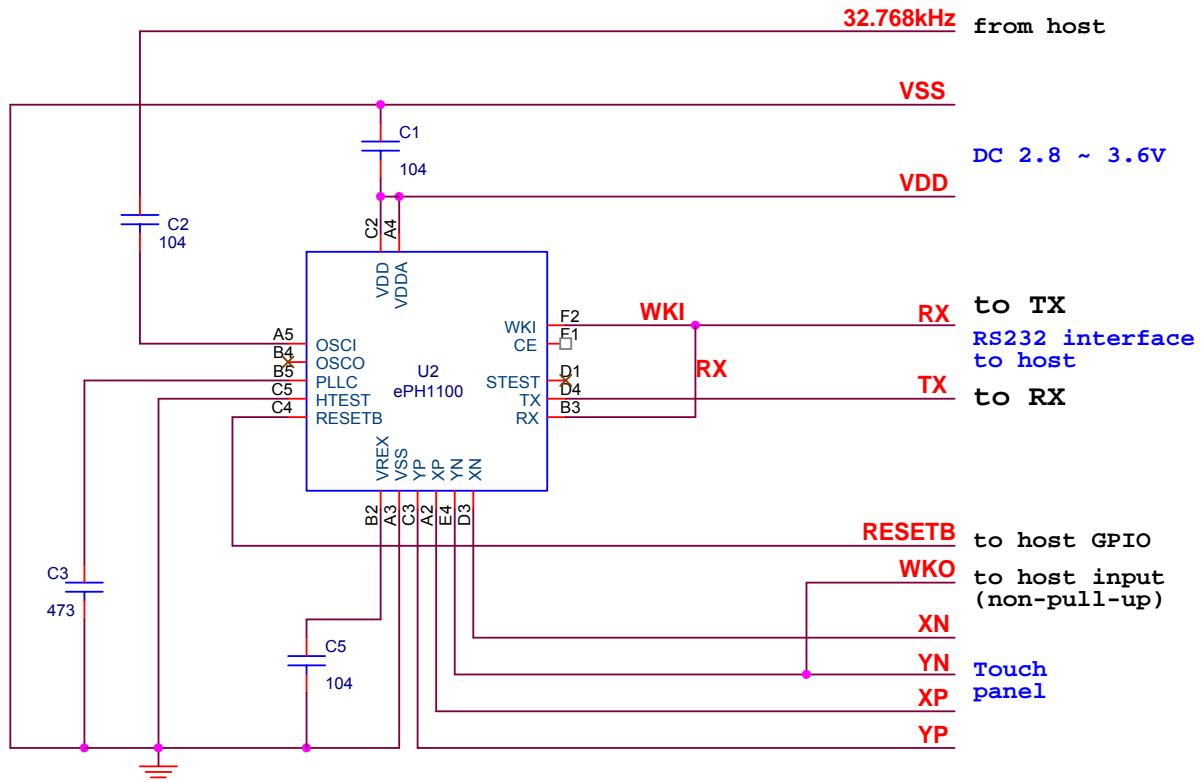

10.2.1 BOM Table

Component	Component P/N	Pin Location	Packaging	Qty
MCU	ePH1100	U2	CSP	1
Capacitor	0.1 μ F (104)	C1, C2, C4, C5	S	4
Capacitor	0.047 μ F (473)	C3	S	1

10.3 Touch Panel and YP, XP, YN, & XN Layout Format

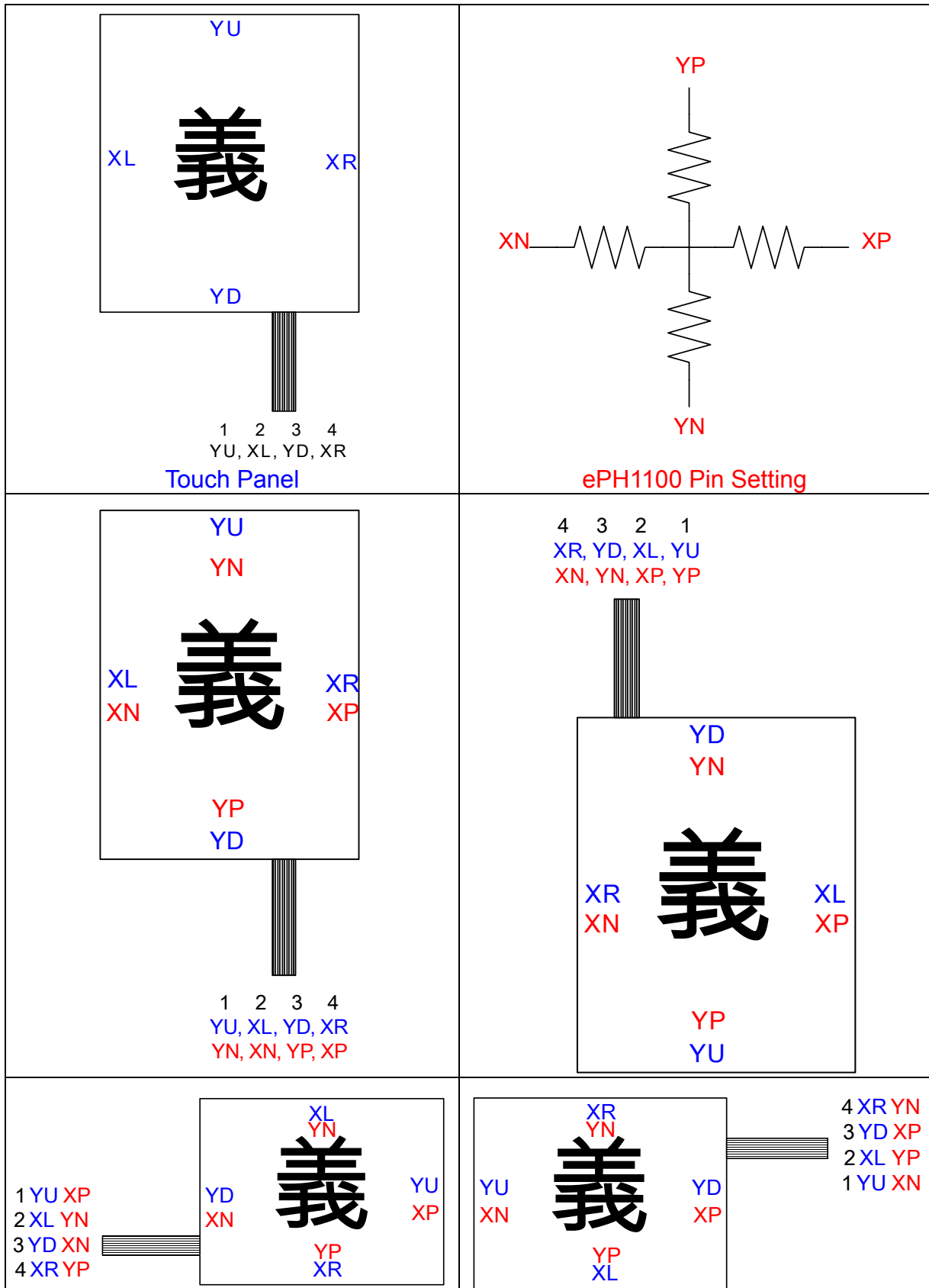

11 HWRE Software Specification

11.1 HWRE Software Description

- The ePH1100 provides nine free-hand input recognition proficiencies; including Chinese character Set I (for both Traditional & Simplified Chinese), Chinese character Set II (for both Traditional & Simplified Chinese), etc.
- You can choose to access the input as you write (inking) with recognized characters feedback, or access the recognized characters only without accessing the inking (input).
- The ePH1100 transmits both hand-written characters and hand-drawn graphics. Graphics inking are transmitted without recognition.
- The ePH1100 can only transmit data to the Host through a defined touch panel button area coordinates (located at a designated area of the touch panel). When you tap and drag on the panel, only the tapping is transmitted. Dragging is ignored.

11.2 Communication Protocol and Command List

11.2.1 Communication Interface: UART

UART parameter: baud rate 9600; no parity check; 8 bits data length.

11.2.2 Command Timing Request

When the Host sends command to the ePH1100, the time between two bytes must be less than 2.7ms. Otherwise, the ePH1100 will not accept the command and accesses the "ACK error" message.

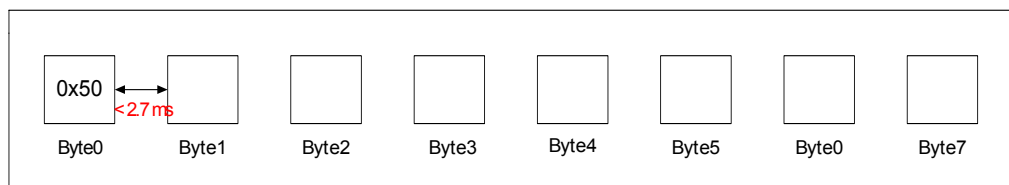

When the Host transmits command to the ePH1100, the time between two consecutive commands must be longer than 10 ms.

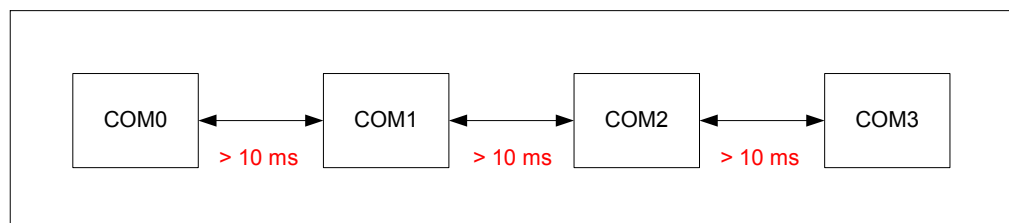

11.2.3 Commands from Host (see Section 11.3 for details)

Command	Brief Description	Command Response	Response at Tapping*
0x33	Wake-up ePH1100	Not applicable	Not applicable
0x10	Execute the set character recognition mode	Instantaneous	Instantaneous
0x14	Execute the set inking transmit switch	Instantaneous	Instantaneous
0x1A	Execute the set pen up (next tapping) waiting time	Instantaneous	As soon as pen is up
0x1B	Recognition before timeout	Instantaneous	As soon as pen is up
0x1C	Host Ready	Instantaneous	Instantaneous
0x1D	Convert recognition & "tap to wake-up" data into even numbered package	Instantaneous	Instantaneous
0x1E	Pen up timeout offset (shorten timeout)	Instantaneous	As soon as pen is up
0x40	Get handwriting firmware version	Instantaneous	Instantaneous
0x41	Output with different code table	Instantaneous	Instantaneous
0x42	Software reset	Instantaneous	Instantaneous
0x43	Abort the current inking	Instantaneous	Instantaneous
0x44	Calibration	Instantaneous	Instantaneous
0x46	Set writing area location	Instantaneous	Instantaneous
0x49	Set Recognition / Graphic mode	Instantaneous	Instantaneous
0x4A	Set power saving mode	Instantaneous	Instantaneous
0x4B	Set A/D resolution	Instantaneous	Instantaneous
0x4C	Rotate touch panel	Instantaneous	Instantaneous

- * 1. Shows which command takes effect immediately when Host sends command to ePH1100 with the pen tapped and held on touch panel.
2. If there is inadequate time to receive the Host command, ePH1100 will initially access the "ACK error" message and wait for the Host to send the correct command within 1.5 sec. After receiving valid command or 1.5 sec timeout, ePH1100 continues to execute the original program.

11.2.4 Responses from ePH1100 (see Section 11.4 for details)

Command	Description
0x00	Ack error
0x16	Inking (written input) coordinates
0x17	Touch panel button area coordinates
0x18	Recognized characters array
0x33	Exit from power saving mode
0x42	Initial power ON
Host command dependent	Ack OK

11.3 Commands from Host Specifications

11.3.1 Wake-up ePH1100 (0x33; 8 Bytes)

Bytes	Function	Length	Data Format	Remarks
0	Header	1	HEX	0x50
1	Command	1	HEX	0x33
2	Parameter length	1	HEX	0x04
3-6	Stuff	4	HEX	0x00; 0x00; 0x00; 0x00
7	Checksum	1	HEX	0xC7

Description: Host can use this command to wake up ePH1100.

Note that this command is applicable only when ePH1100 is in idle mode and it cannot ACK any response when in FAST mode.

Example:

Command / Response	Host	ePH1100
Command wake-up	50 33 04 00 00 00 00 C7	
Command wake-up response		50 33 04 FF FF FF FF 19

11.3.2 Set Character Recognition Mode (0x10; 8 Bytes)

Bytes	Function	Length	Data Format	Remarks
0	Header	1	HEX	0x50
1	Command	1	HEX	0x10
2	Parameter length	1	HEX	0x04
3-4	Parameter	2	HEX	User define
5-6	Stuff	2	HEX	0xFF; 0xFF
7	Checksum	1	HEX	

Description: Set recognition type

Recognition Type Definition: Total 10 bits (Default value: 0x3F01)

■ **Byte 3**

Bit No.	Recognition Type Description	Recognition Type Setting
0	Set Chinese character Set I	0x0100
1	Set Chinese character Set II	0x0200
2	Set capital letter	0x0400
3	Set numeral	0x0800
4	Set symbol	0x1000
5	Set default gesture	0x2000
6	Set hiragana	0x4000
7	Set katakana	0x8000

■ **Byte 4**

Bit No.	Recognition Type Description	Recognition Type Setting
8	Set small letter	0x0001
9	“Pu-Fu-Mo-Fo” Traditional Chinese phonetics	0x0002

Stroke (Gesture) Definition:

Default Stroke Description	Default Stroke Setting
BackSpace	0x0008
Return/Enter	0x000D
Delete	0x0010
SPACE	0x0020

The following graphs show the default writing stroke. Dot on each stroke shows where to begin. Then lift the pen (stylus) at the end of the stroke. You only need to lightly tap and drag on the touch panel.

BackSpace (0x0008) 

Return/Enter (0x000D) 

Delete (0x0010) 

Space (0x0020) 

Example:

Command / Response	Host	ePH1100
COM (set recognition type)	50 10 04 FF 01 FF FF 19	
ACK (set recognition type)		50 10 04 FF FF FF FF 59

11.3.3 Set Inking Transmit Switch (0x14; 8 Bytes)

Bytes	Function	Length	Data Format	Remarks
0	Header	1	HEX	0x50
1	Command	1	HEX	0x14
2	Parameter length	1	HEX	0x04
3	User defined	1	HEX	On :0x01/Off: 0x00
4-6	Stuff	3	HEX	0xFF; 0xFF; 0xFF
7	Checksum	1	HEX	

Description: Select whether to transmit or not the inking (written input). Default is to transmit (ON). During Graphic mode, inking transmit switch OFF command is ignored, but is carried out once you enter Recognition mode.

Examples:

1. Transmit inking coordinates (0x14)

Command / Response	Host	ePH1100
COM (Set inking transmit)	50 14 04 01 FF FF FF 3A	
ACK (Set inking transmit)		50 14 04 FF FF FF FF FD

2. Do not transmit inking coordinates (0x14)

Command / Response	Host	ePH1100
COM (Do not transmit inking)	50 14 04 00 FF FF FF 2C	
ACK (Do not transmit inking)		50 14 04 FF FF FF FF FD

11.3.4 Set Pen Up (Lifting of Stylus) Waiting Time (0x1A; 8 Bytes)

Bytes	Function	Length	Data Format	Remarks
0	Header	1	HEX	0x50
1	Command	1	HEX	0x1A
2	Parameter length	1	HEX	0x04
3	User defined	1	HEX	
4-6	Stuff	3	HEX	0xFF; 0xFF; 0xFF
7	Checksum	1	HEX	

Description: Set pen up (lifting of stylus) waiting time.

Pen Up Waiting Time Setting:

1. The ePH1100 divides the pen up time into 10 steps. 1~10 are valid values, other values represent infinite waiting. Default is 600 ms.
2. Every step increases by an increment of 200ms. 1 represents 1x200 ms, and 10 represent 10x200 ms. If infinite pen up time is used, ePH1100 must initially receive the "Recognizing immediately (0x1B)" command before executing character recognition.

Example:

Command / Response	Host	ePH1100
COM (set pen up waiting time)	50 1A 04 03 FF FF FF AF	–
ACK (set pen up waiting time)	–	50 1A 04 FF FF FF FF 44

11.3.5 Perform Recognition Immediately, i.e., Before Time-out (0x1B; 8 Bytes)

Bytes	Function	Length	Data Format	Remarks
0	Header	1	HEX	0x50
1	Command	1	HEX	0x1B
2	Parameter length	1	HEX	0x04
3-6	Stuff	4	HEX	0xFF; 0xFF; 0xFF; 0xFF
7	Checksum	1	HEX	0x6D

Description: Proceed to character recognition immediately.

Example:

Command / Response	Host	ePH1100
COM (recognize immediately)	50 1B 04 FF FF FF FF 6D	
ACK (can not recognize immediately)		50 1B 04 00 00 00 00 B3
ACK (can Recognize immediately)		50 1B 04 FF FF FF FF 6D

11.3.6 Host Ready (0x1C; 8 Bytes)

Bytes	Function	Length	Data Format	Remarks
0	Header	1	HEX	0x50
1	Command	1	HEX	0x1C
2	Parameter length	1	HEX	0x04
3-6	Stuff	4	HEX	0xFF; 0xFF; 0xFF; 0xFF
7	Checksum	1	HEX	0xB2

Description: With this command, the Host notifies the ePH1100, “I am ready.” You can then start transmitting data after wake-up occurs (by tapping the touch pad).

Example: The same as in Section 11.4.5, *Exit from Power Saving Mode*.

11.3.7 Set Even Numbered Package for Recognizing Characters and to Trigger Wake-Up by Tapping Touch Pad (0x1D; 8 Bytes)

Bytes	Function	Length	Data Format	Remarks
0	Header	1	HEX	0x50
1	Command	1	HEX	0x1D
2	Parameter length	1	HEX	0x04
3	User defined	1	HEX	Off: 0x00 / On: 0x01
4-6	Stuff	3	HEX	0xFF; 0xFF; 0xFF
7	Checksum	1	HEX	

Description: This command defines the data format (even numbered) for recognizing characters and for responding to touch pad tapping to wake-up ePH1100 (Add 0x00).

Example:

Command / Response	Host	ePH1100
COM (even package)	50 1D 04 01 FF FF FF 5C	-
ACK (even package)	-	50 1D 04 FF FF FF FF 9B

11.3.8 Pen Up (Lifting of Stylus) Time-out Offset (0x1E; 8 Bytes)

Bytes	Function	Length	Data Format	Remarks
0	Header	1	HEX	0x50
1	Command	1	HEX	0x1E
2	Parameter length	1	HEX	0x04
3	User defined	1	HEX	On: 0x01 / Off: 0x00
4-6	Stuff	3	HEX	0xFF; 0xFF; 0xFF
7	Checksum	1	HEX	

Description: This command subtracts 100ms from original setup pen up time.

Examples:

- Original Pen-up Time = 200ms

Command / Response	Host	ePH1100
COM(Pen up time 200ms)	50 1A 04 01 FF FF FF 83	-
ACK(Pen up time 200ms)	50 1A 04 FF FF FF FF 44	-
COM (Pen up timeout offset)	50 1E 04 01 FF FF FF 27	-
ACK (Pen up timeout offset) 200-100=100ms	-	50 1E 04 FF FF FF FF E0

■ **Original Pen-up Time = 400ms**

Command / Response	Host	ePH1100
COM (Pen-up time 400ms)	50 1A 04 02 FF FF FF B9	–
ACK (Pen-up time 400ms)	50 1A 04 FF FF FF FF 44	–
COM (Pen-up time-out offset)	50 1E 04 01 FF FF FF 27	–
ACK (Pen-up time-out offset) 400-100=300ms	–	50 1E 04 FF FF FF FF E0

11.3.9 Access the HWRE Firmware Version (0x40; 8 Bytes)

Bytes	Function	Length	Data Format	Remarks
0	Header	1	HEX	0x50
1	Command	1	HEX	0x40
2	Parameter length	1	HEX	0x04
3-6	Stuff	4	HEX	0xFF; 0xFF; 0xFF; 0xFF
7	Checksum	1	HEX	0xB1

Description: Access the Handwriting Recognition firmware version.

Example:

Command / Response	Host	ePH1100
COM (access firmware version)	50 40 04 FF FF FF FF B1	
ACK (access firmware version)		50 40 04 02 23 51 11 D3 == == == == (V2.21 : 2005/1/11)

11.3.10 Output with Different Code Table (0x41; 8 Bytes)

Bytes	Function	Length	Data Format	Remarks
0	Header	1	HEX	0x50
1	Command	1	HEX	0x41
2	Parameter length	1	HEX	0x04
3	User defined	1	HEX	0x00:Traditional / Simplified combo 0x01:Traditional only 0x02:Simplified only
4-6	Stuff	3	HEX	0xFF; 0xFF; 0xFF
7	Checksum	1	HEX	

Description: ePH1100 offers three code tables for your selection. 0~2 are valid values. Any other invalid values are regarded as default value "0." The difference between the three code tables are as listed below.

- "0" : Default code table; Traditional / Simplified Chinese combo
(Traditional in – Traditional out; Simplified in – Simplified out)
write "华" → recognized as "華" (0x534e)
write "華" → recognized as "華" (0x83ef)
- "1" : Traditional Chinese only
(Traditional or Simplified in – always Traditional out)
write "华" → recognized as "華" (0x83ef)
write "華" → recognized as "華" (0x83ef)
- "2" : Simplified Chinese only
(Traditional or Simplified in – always Simplified out)
write "华" → recognized as "华" (0x534e)
write "華" → recognized as "华" (0x534e)

Example:

Command / Response	Host	ePH1100
COM (output with different code table)	50 41 04 02 FF FF FF 65	–
ACK (output with different code table)	–	50 41 04 FF FF FF FF 98

11.3.11 Software Reset (0x42; 8 Bytes)

Bytes	Function	Length	Data Format	Remarks
0	Header	1	HEX	0x50
1	Command	1	HEX	0x42
2	Parameter length	1	HEX	0x04
3-6	Stuff	4	HEX	0xFF; 0xFF; 0xFF; 0xFF
7	Checksum	1	HEX	0xE3

Description: Host can use this command to reset the ePH1100. The ePH1100 will reset to initial power on when this command is executed and all settings will return to its default values.

Example:

Command / Response	Host	ePH1100
COM (software reset)	50 42 04 FF FF FF FF E3	
ACK (software reset)		50 42 04 FF FF FF FF E3
COM (initial power on)		50 42 04 00 00 00 00 3D

11.3.12 Abort the Current Inking (0x43; 8 Bytes)

Bytes	Function	Length	Data Format	Remarks
0	Header	1	HEX	0x50
1	Command	1	HEX	0x43
2	Parameter length	1	HEX	0x04
3-6	Stuff	4	HEX	0xFF; 0xFF; 0xFF; 0xFF
7	Checksum	1	HEX	0xCA

Description: Clear the current inking.

Example:

Command / Response	Host	ePH1100
COM (clear current inking)	50 43 04 FF FF FF FF CA	–
ACK (clear current inking)	–	50 43 04 FF FF FF FF CA

11.3.13 Calibration (0x44; 8 Bytes)

Bytes	Function	Length	Data Format	Remarks
0	Header	1	HEX	0x50
1	Command	1	HEX	0x44
2	Parameter length	1	HEX	0x04
3-6	Stuff	4	HEX	0xFF; 0xFF; 0xFF; 0xFF;
7	Checksum	1	HEX	0x15

Description: Use this command to request for ePH1100 calibration. The ePH1100 cannot determine whether the executed calibration command is successful or not. The Host should accommodate this function.

Example:

Command / Response	Host	ePH1100
COM (calibration)	50 44 04 FF FF FF FF 15	–
ACK (calibration)	–	50 44 04 FF FF FF FF 15
COM (calibrate: top- left)	–	50 44 04 25 36 FF FF F3
COM (calibrate: bottom- right)	–	50 44 04 FF FF D7 CE 84

11.3.14 Set Writing Area Location (0x46; 8 Bytes)

Bytes	Function	Length	Data Format	Remarks
0	Header	1	HEX	0x50
1	Command	1	HEX	0x46
2	Parameter length	1	HEX	0x04
3	Top-left X coordinate	1	HEX	0x00—0xFE
4	Top-left Y coordinate	1	HEX	0x00—0xFE
5	Bottom-right X coordinate	1	HEX	0x00—0xFE
6	Bottom-right Y coordinate	1	HEX	0x00—0xFE
7	Checksum	1	HEX	

Description: Set the desired location of the writing area.

Example:

Command / Response	Host	ePH1100
COM (set writing area location)	50 46 04 10 10 F0 F0 96	
ACK (set writing area location)		50 46 04 FF FF FF FF 47

11.3.15 Set Recognition Mode / Graphic Mode (0x49; 8 Bytes)

Bytes	Function	Length	Data Format	Remarks
0	Header	1	HEX	0x50
1	Command	1	HEX	0x49
2	Parameter length	1	HEX	0x04
3	User defined	1	HEX	Recognition:0x00 / Graphic:0x01
4-6	Stuff	3	HEX	0xFF; 0xFF; 0xFF
7	Checksum	1	HEX	

Description: Default is Recognition mode. Graphic mode transmission coordinates are similar to Recognition mode except recognition is not processed under Graphic mode.

Example:

1. Recognition Mode:

Command / Response	Host	ePH1100
COM (set recognition mode)	50 49 04 00 FF FF FF 06	–
ACK (set recognition mode)	–	50 49 04 FF FF FF FF D7

2. Graphic Mode (0x49):

Command / Response	Host	ePH1100
COM (set Graphic Mode)	50 49 04 01 FF FF FF 10	–
ACK (set Graphic Mode)	–	50 49 04 FF FF FF FF D7

11.3.16 Set Power Saving Mode (0x4A; 8 Bytes)

Bytes	Function	Length	Data Format	Remarks
0	Header	1	HEX	0x50
1	Command	1	HEX	0x4A
2	Parameter length	1	HEX	0x04
3	User defined	1	HEX	Enable "Tap to wake-up": 0x01 Disable "Tap to wake-up": 0x00
4	User defined	1	HEX	Idle time for idle mode to take effect: 1~20
5-6	Stuff	2	HEX	0xFF; 0xFF
7	Checksum	1	HEX	

Description:

- Byte 3 represents the tap to wake-up switch
0x01 → Enable "Tap to wake-up" function
0x00 → Disable "Tap to wake-up" function
- Byte 4 represents the idle (no input) time before power saving mode takes effect. The ePH1100 divides the time into 20 steps; i.e., 1~20 (valid values). Any other value above 20 is considered as "20." Every step increases by about 15 seconds. "1" represents 1×15 seconds and 20 represent 20×15 seconds. "0" value (default) is used to prevent ePH1100 from entering into power saving mode.
- To instantly enter into power saving mode, add "0x80" to the defined idle time. Note that the instant power saving mode works only once and the defined idle time takes over.

Example:

Command / Response	Host	ePH1100
COM (set power saving mode)	50 4A 04 01 02 FF FF 96	–
ACK (set power saving mode)	–	50 4A 04 FF FF FF FF AC

11.3.17 Set A/D Resolution (0x4B; 8 Bytes)

Bytes	Function	Length	Data Format	Remarks
0	Header	1	HEX	0x50
1	Command	1	HEX	0x4B
2	Parameter length	1	HEX	0x04
3	User defined	1	HEX	A/D 8 bit resolution : 0x01 A/D 10 bit resolution : 0x00
4~6	Stuff	3	HEX	0xFF; 0xFF; 0xFF
7	Checksum	1	HEX	

Description: ePH1100 supports two A/D resolutions: 8-bit or 10-bit (default is 8-bit).

Example:

Command / Response	Host	ePH1100
COM (set A/D resolution:8 bit)	50 4B 04 01 FF FF FF 42	-
COM (set A/D resolution:10 bit)	50 4B 04 00 FF FF FF 54	-
ACK (set A/D resolution)	-	50 4B 04 FF FF FF FF 85

11.3.18 Rotate Touch Panel (0x4C; 8 Bytes)

Bytes	Function	Length	Data Format	Remarks
0	Header	1	HEX	0x50
1	Command	1	HEX	0x4C
2	Parameter length	1	HEX	0x04
3	User defined	1	HEX	-
4~6	Stuff	3	HEX	0xFF; 0xFF; 0xFF
7	Checksum	1	HEX	-

Description: Exchange touch panel X/Y axis.

■ **Byte 3**

Bit 7	Bit 6	Bit 5	Bit 4	Bit 3	Bit 2	Bit 1	Bit 0
0	-	-	-	0	0	0	0

Bit 6=1 represents XN/YN exchange, XP/YP exchange

Bit 5=1 represents XN/XP exchange, Y direction fixed

Bit 4=1 represents YN/YP exchange, X direction fixed

Bit 7, Bit0~3 must be fixed to 0.

Example:

Command / Response	Host	ePH1100
COM (rotate touch panel)	50 4C 04 70 FF FF FF B9	-
ACK (rotate touch panel)	-	50 4C 04 FF FF FF FF 5A

11.4 Responses from the ePH1100 Specifications

11.4.1 ACK_ERROR (0x00; 8 Bytes)

Bytes	Function	Length	Data format	Remark
0	Header	1	HEX	0x50
1	Command	1	HEX	0x00
2	Parameter length	1	HEX	0x04
3-6	Stuff	4	HEX	0x00; 0x00; 0x00; 0x00;
7	Checksum	1	HEX	0x19

Description: If Host sends an invalid command, the ePH1100 will respond with "ACK ERROR" to Host.

Example:

Command / Response	Host	ePH1100
Response (ACK error)	-	50 00 04 00 00 00 00 19

11.4.2 Inking (Access to Written Input) Coordinates (0x16; 6 Bytes)

Bytes	Function	Length	Data Format	Remarks
0	Header	1	HEX	0x50
1	Command	1	HEX	0x16
2	Parameter length	1	HEX	0x02
3	X coordinate	1	HEX	0x00—0xFE
4	Y coordinate	1	HEX	0x00—0xFE
5	Checksum	1	HEX	-

Description:

- Normal inking: when the stylus taps the touch panel, the coordinate is transmitted.
- Stroke over: when the stylus leaves the touch panel, “0xFF, 0xFF” is transmitted.
- Word over: when a word is completed, “0xFF, 0x00” is transmitted.

Example:

ePH1100 Inking Response	Description
50 16 02 60 60 ED	=>Normal inking
50 16 02 65 61 AB 50 16 02 6A 61 68 50 16 02 6F 60 2E 50 16 02 74 5F 53	
50 16 02 FF FF 1B	=>Stroke over
50 16 02 40 8D CE 50 16 02 45 8F 81 50 16 02 4A 8F 42 50 16 02 4F 8F 03 50 16 02 55 8E D1 50 16 02 5C 8E 6C 50 16 02 62 8D 4A 50 16 02 67 8D 0B 50 16 02 6F 8C A4 50 16 02 74 8B 71 50 16 02 79 8A 9F 50 16 02 7E 8A F4 50 16 02 83 89 00 50 16 02 89 89 82 50 16 02 8E 88 EE 50 16 02 93 87 7D 50 16 02 98 86 ED	
50 16 02 FF FF 1B	=>Stroke over
50 16 02 FF 00 E8	=>Word over
50 18 15 0A 8C 4E A0 4E AB 51 35 6C 09 4E 3D 00 3A 00 3B 00 69 00 21 00 F9	

11.4.3 Touch Panel Button Coordinates (0x17; 6 Bytes; 0xFF is Pen Up Signal)

Bytes	Function	Length	Data Format	Remarks
0	Header	1	HEX	0x50
1	Command	1	HEX	0x17
2	Parameter length	1	HEX	0x02
3	X coordinate	1	HEX	0x00—0xFE; 0xFF
4	Y coordinate	1	HEX	0x00—0xFE; 0xFF
5	Checksum	1	HEX	

Description: The default values of the touch panel writing area are (0x10, 0x10) and (0xF0, 0xF0). The ePH1100 will transmit coordinates through the touch panel button area (0x17) if the tapping occurs outside the writing area.

Example:

Command / Response	Host	ePH1100
Response (touch panel button)		50 17 02 01 01 3B

11.4.4 Recognized Characters Array (0x18; Maximum 25 Bytes; Minimum 6 Bytes)

Bytes	Function	Length	Data Format	Remarks
0	Header	1	HEX	0x50
1	Command	1	HEX	0x18
2	Parameter length	1	HEX	–
3	Max. qty. of characters	1	HEX	–
4	Characters (low byte)	1	HEX	–
5	Characters (high byte)	1	HEX	–
....				
N	Checksum	1	HEX	–

Description: Recognized characters array package. No character will utilize 6 bytes.

Example:

Command / Response	Host	ePH1100
Response (characters)	–	50 18 03 01 08 00 3A

11.4.5 Exit from Power Saving Mode (0x33; 8 Bytes)

Bytes	Function	Length	Data Format	Remarks
0	Header	1	HEX	0x50
1	Command	1	HEX	0x33
2	Parameter length	1	HEX	0x04
3-6	Stuff	4	HEX	0xFF; 0xFF; 0xFF; 0xFF
7	Checksum	1	HEX	0x19

Description:

A. Wake-up Conditions

When ePH1100 enters power saving mode, ePH1100 will wake-up when one of the following conditions occurs:

1. Touch panel wake-up (“tap to wake-up”):

Tap the touch panel & ePH1100 wakes-up and sends 1 byte (0x00) to Host. Host must respond “Host ready” within 7.5 sec, else ePH1100 will enter power saving mode again. Note that ePH1100 must have the tap-to-wakeup function enabled in order to perform this function.

Example:

Command / Response	Host	ePH1100
Touch panel wakeup response	–	00
Com (Host ready)	50 1C 04 FF FF FF FF B2	–
ACK (Host ready)	–	50 1C 04 FF FF FF FF B2
Response	–	50 33 04 FF FF FF FF 19

2. Command wake-up: Host executes command “50 33 04 00 00 00 00 C7” to wake up the ePH1100.

Example:

Command / Response	Host	ePH1100
Command wake-up	50 33 04 00 00 00 00 C7	–
Command wake-up response	–	50 33 04 FF FF FF FF 19

B. ePH1100 Wake-up Response Signal Details

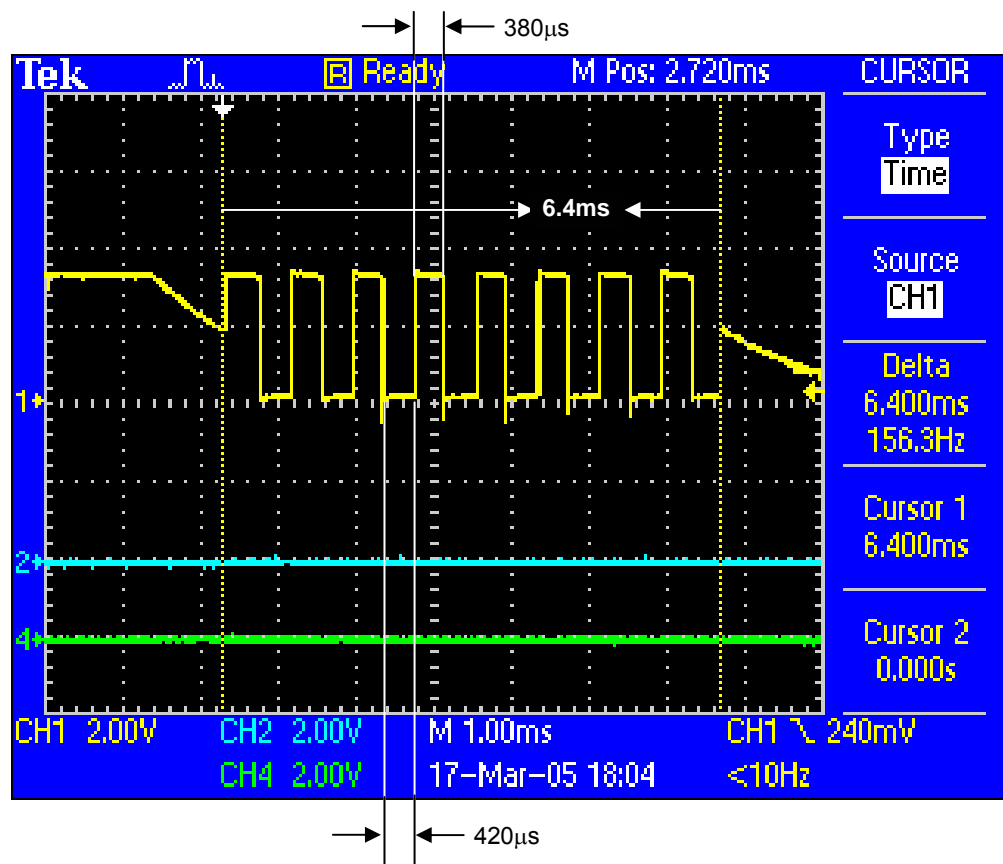

The above waveform illustrates the characteristics of the signal which ePH1100 sends to Host after it wakes up from Idle mode. This signal is composed of 8 clocks with a total width of 6.4ms and is applicable only under "Tap to wake-up" condition.

11.4.6 Initial Power On (0x42; 8 Bytes)

Bytes	Function	Length	Data Format	Remarks
0	Header	1	HEX	0x50
1	Command	1	HEX	0x42
2	Parameter length	1	HEX	0x04
3-6	Stuff	4	HEX	0x00; 0x00; 0x00; 0x00;
7	Checksum	1	HEX	0x3D

Description: When the ePH1100 is powered on, it will send “Initial power on” response to the Host.

Example:

Command / Response	Host	ePH1100
Response (initial power on)	–	50 42 04 00 00 00 00 3D

11.4.7 ACK_OK (Carry Out Host Command; 8 Bytes)

Bytes	Function	Length	Data format	Remark
0	Header	1	HEX	0x50
1	Follow Host command	1	HEX	–
2	Parameter length	1	HEX	0x04
3-6	Stuff	4	HEX	0xFF,0xFF,0xFF,0xFF
7	Checksum	1	HEX	–

Description: After executing the Host command, the ePH1100 response with an ACK OK format which corresponds to the given command.

Example: Refer to each command sample provided in this specification.

11.5 Checksum Program

Reference : www.6502.org:

Source: CRC Calculations

```
CRC-8 8bits checksum table
const BYTE CRCTable[256]={
0x00,0x07,0x0E,0x09,0x1C,0x1B,0x12,0x15,0x38,0x3F,0x36,0x31,
0x24,0x23,0x2A,0x2D,0x70,0x77,0x7E,0x79,0x6C,0x6B,0x62,0x65,
0x48,0x4F,0x46,0x41,0x54,0x53,0x5A,0x5D,0xE0,0xE7,0xEE,0xE9,
0xFC,0xFB,0xF2,0xF5,0xD8,0xDF,0xD6,0xD1,0xC4,0xC3,0xCA,0xCD,
0x90,0x97,0x9E,0x99,0x8C,0x8B,0x82,0x85,0xA8,0xAF,0xA6,0xA1,
0xB4,0xB3,0xBA,0xBD,0xC7,0xC0,0xC9,0xCE,0xDB,0xDC,0xD5,0xD2,
0xFF,0xF8,0xF1,0xF6,0xE3,0xE4,0xED,0xEA,0xB7,0xB0,0xB9,0xBE,
0xAB,0xAC,0xA5,0xA2,0x8F,0x88,0x81,0x86,0x93,0x94,0x9D,0x9A,
0x27,0x20,0x29,0x2E,0x3B,0x3C,0x35,0x32,0x1F,0x18,0x11,0x16,
0x03,0x04,0x0D,0x0A,0x57,0x50,0x59,0x5E,0x4B,0x4C,0x45,0x42,
0x6F,0x68,0x61,0x66,0x73,0x74,0x7D,0x7A,0x89,0x8E,0x87,0x80,
0x95,0x92,0x9B,0x9C,0xB1,0xB6,0xBF,0xB8,0xAD,0xAA,0xA3,0xA4,
0xF9,0xFE,0xF7,0xF0,0xE5,0xE2,0xEB,0xEC,0xC1,0xC6,0xCF,0xC8,
0xDD,0xDA,0xD3,0xD4,0x69,0x6E,0x67,0x60,0x75,0x72,0x7B,0x7C,
0x51,0x56,0x5F,0x58,0x4D,0x4A,0x43,0x44,0x19,0x1E,0x17,0x10,
0x05,0x02,0x0B,0x0C,0x21,0x26,0x2F,0x28,0x3D,0x3A,0x33,0x34,
0x4E,0x49,0x40,0x47,0x52,0x55,0x5C,0x5B,0x76,0x71,0x78,0x7F,
0x6A,0x6D,0x64,0x63,0x3E,0x39,0x30,0x37,0x22,0x25,0x2C,0x2B,
0x06,0x01,0x08,0x0F,0x1A,0x1D,0x14,0x13,0xAE,0xA9,0xA0,0xA7,
0xB2,0xB5,0xBC,0xBB,0x96,0x91,0x98,0x9F,0x8A,0x8D,0x84,0x83,
0xDE,0xD9,0xD0,0xD7,0xC2,0xC5,0xCC,0xCB,0xE6,0xE1,0xE8,0xEF,
0xFA,0xFD,0xF4,0xF3};
```

```
Code of produce and verify checksum :
unsigned char GenerateCRC(unsigned char *Packet,
    int size)
{
int i;
unsigned char value;
value=0;
for(i=0;i<size-1;i++){
    value ^= Packet[i];
    value=CRCTable[value];
}
return value;
}
```

```
void main(void)
{
    unsigned char Packet[8]; //produce checksum of 8bytes package
    int I;
    for(I=0;I<8;I++)Packet[I]=0;
    Packet[7]=GenerateCRC(Packet,sizeof(Packet)) //checksum place the eighth
                                                byte }
}
```

12 Package LQFP44

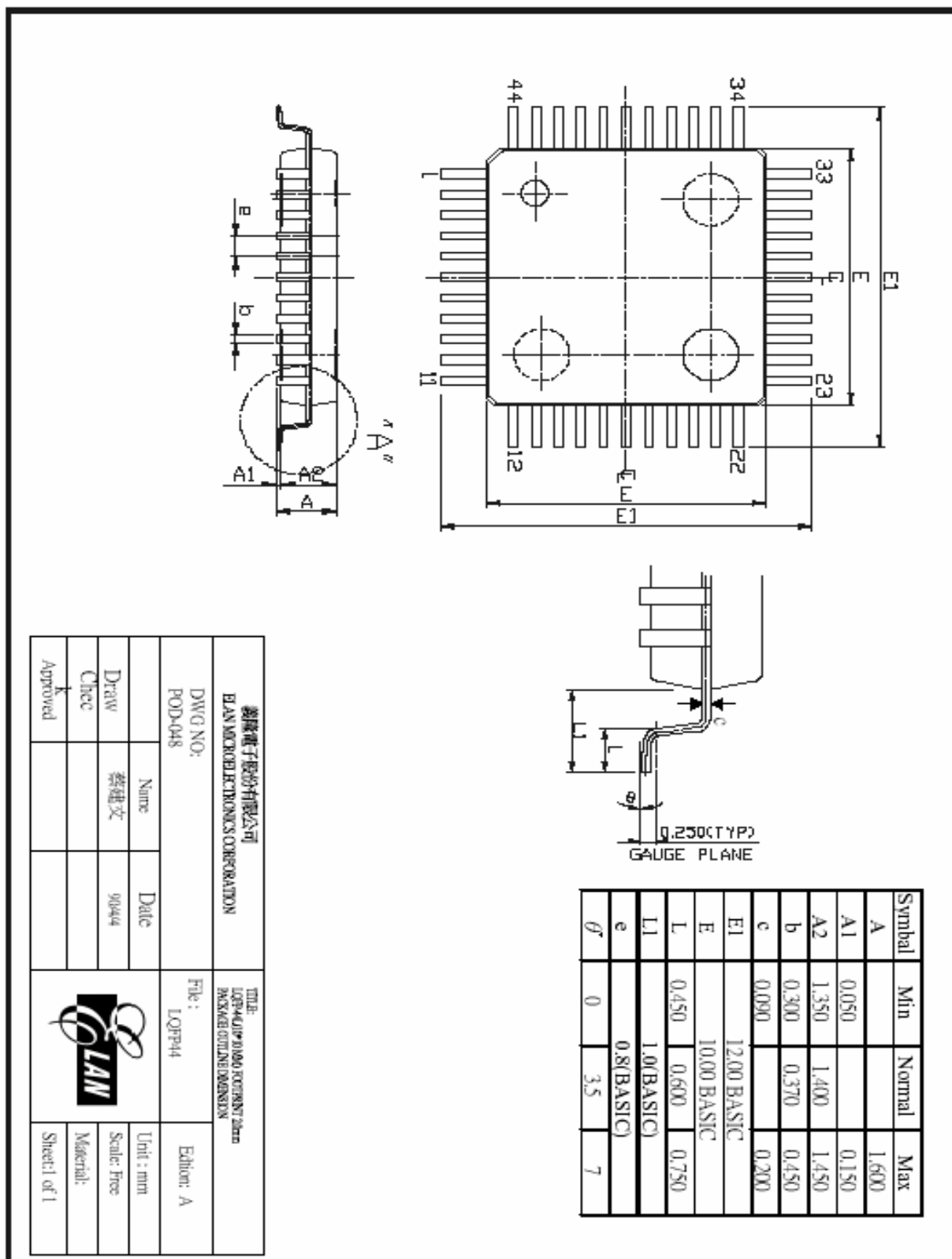

13 Tape Reel Specification

