

---

**EPD3332**

**RISC II Series  
Microcontroller**

**Product  
Specification**

**DOC. VERSION 2.4**

**ELAN MICROELECTRONICS CORP.**

November 2005

---



---

**Trademark Acknowledgments:**

IBM is a registered trademark and PS/2 is a trademark of IBM

Windows is a trademark of Microsoft Corporation

ELAN and ELAN logo  are trademarks of ELAN Microelectronics Corporation

Copyright © 2005 by ELAN Microelectronics Corporation

**All Rights Reserved**

Printed in Taiwan

The contents of this specification are subject to change without further notice. ELAN Microelectronics assumes no responsibility concerning the accuracy, adequacy, or completeness of this specification. ELAN Microelectronics makes no commitment to update, or to keep current the information and material contained in this specification. Such information and material may change to conform to each confirmed order.

In no event shall ELAN Microelectronics be made responsible for any claims attributed to errors, omissions, or other inaccuracies in the information or material contained in this specification. ELAN Microelectronics shall not be liable for direct, indirect, special incidental, or consequential damages arising from the use of such information or material.

The software (if any) described in this specification is furnished under a license or nondisclosure agreement, and may be used or copied only in accordance with the terms of such agreement.

ELAN Microelectronics products are not intended for use in life support appliances, devices, or systems. Use of ELAN Microelectronics product in such applications is not supported and is prohibited.

NO PART OF THIS SPECIFICATION MAY BE REPRODUCED OR TRANSMITTED IN ANY FORM OR BY ANY MEANS WITHOUT THE EXPRESSED WRITTEN PERMISSION OF ELAN MICROELECTRONICS.



---

**ELAN MICROELECTRONICS CORPORATION**

---

**Headquarters:**

No. 12, Innovation Road 1  
Hsinchu Science Park  
Hsinchu, Taiwan 30077  
Tel: +886 3 563-9977  
Fax: +886 3 563-9966  
<http://www.emc.com.tw>

**Hong Kong:**

**Elan (HK) Microelectronics Corporation, Ltd.**  
Rm. 1005B, 10/F Empire Centre  
68 Mody Road, Tsimshatsui  
Kowloon, HONG KONG  
Tel: +852 2723-3376  
Fax: +852 2723-7780  
[elanhk@emc.com.hk](mailto:elanhk@emc.com.hk)

**USA:**

**Elan Information Technology Group**  
1821 Saratoga Ave., Suite 250  
Saratoga, CA 95070  
USA  
Tel: +1 408 366-8223  
Fax: +1 408 366-8220

**Europe:**

**Elan Microelectronics Corp. (Europe)**  
Siewerdtstrasse 105  
8050 Zurich, SWITZERLAND  
Tel: +41 43 299-4060  
Fax: +41 43 299-4079  
<http://www.elan-europe.com>

**Shenzhen:**

**Elan Microelectronics Shenzhen, Ltd.**  
SSMEC Bldg., 3F, Gaoxin S. Ave.  
Shenzhen Hi-Tech Industrial Park  
Shenzhen, Guandong, CHINA  
Tel: +86 755 2601-0565  
Fax: +86 755 2601-0500

**Shanghai:**

**Elan Microelectronics Shanghai Corporation, Ltd.**  
23/Bldg. #115 Lane 572, Bibo Road  
Zhangjiang Hi-Tech Park  
Shanghai, CHINA  
Tel: +86 021 5080-3866  
Fax: +86 021 5080-4600

---

# Contents

<b>1</b>	<b>General Description</b> .....	<b>1</b>
1.1	Applications.....	2
<b>2</b>	<b>Features</b> .....	<b>2</b>
2.1	MCU Features.....	2
2.2	Peripheral.....	2
2.3	Internal Specification.....	3
2.4	ELAN Software Support (Option).....	3
<b>3</b>	<b>Block Diagram</b> .....	<b>4</b>
<b>4</b>	<b>Pin Assignment</b> .....	<b>5</b>
<b>5</b>	<b>Pin Description</b> .....	<b>6</b>
<b>6</b>	<b>Code Option</b> .....	<b>7</b>
<b>7</b>	<b>Function Description</b> .....	<b>9</b>
7.1	Reset Function.....	9
7.1.1	Power-up and Reset Timing.....	9
7.1.2	Register Initial Values.....	11
7.2	Oscillator System .....	13
7.2.1	32.768kHz Crystal or 32.8kHz RC .....	13
7.2.2	Phase Locked Loop (PLL).....	13
7.3	MCU Operation Mode .....	15
7.4	Wake-up Function.....	17
7.5	Interrupt.....	18
7.5.1	Input Port A Interrupt .....	18
7.5.2	Capture Interrupt .....	19
7.5.3	Speech Timer Interrupt.....	19
7.5.4	Timer 0, Timer 1, and Timer 2 Interrupts .....	19
7.5.5	Peripheral Interrupt.....	20
7.6	Program ROM Map.....	20
7.7	Data ROM Map .....	21
7.8	RAM Map Register (RAM Size: 128 Bytes + 16 Banks ×128 Bytes = 2176 Bytes).....	21
7.9	LCD RAM Map.....	25
7.10	Special Register Description .....	26

<b>8</b>	<b>Peripheral</b> .....	<b>33</b>
8.1	Timer 0 (16-bit Timer with Capture and Event Counter Functions).....	33
8.2	Timer 1 (8 Bits).....	38
8.3	Timer 2 (8 Bits).....	41
8.4	IR Generator: IROT (Port B.2) Pin.....	44
8.5	Watchdog Timer (WDT).....	45
8.6	Universal Asynchronous Receiver Transmitter (UART).....	47
8.6.1	Data Format in UART.....	48
8.6.2	UART Modes.....	48
8.6.3	UART Transmit Data.....	48
8.6.4	UART Receive Data.....	49
8.6.5	UART Baud Rate Generator.....	49
8.6.6	UART Applicable Registers.....	50
8.6.7	Transmit Counter Timing.....	53
8.6.8	UART Transmit Operation (8-Bit Data with Parity Bit).....	53
8.6.9	Receive Counter Timing.....	54
8.7	A/D Converter.....	56
8.7.1	A/D Converter Applicable Registers.....	57
8.7.2	Timing Diagram of General A/D Converter Application.....	60
8.7.3	Correlation between A/D Converter and MCU Mode.....	60
8.7.4	A/D Converter Flowchart.....	62
8.8	Key I/O.....	64
8.8.1	Automatic Key Scan or Software Key Scan.....	64
8.8.2	Input/Output Key Applicable Registers.....	68
8.9	LCD Driver.....	72
8.9.1	LCD Code Option.....	74
8.10	Serial Peripheral Interface (SPI).....	82
8.10.1	SPI Pin Description.....	84
8.10.2	SPI Applicable Registers.....	84
8.10.3	SPI Timing Diagrams.....	87
8.11	Melody/Speech Synthesizer.....	90
8.11.1	Melody Function.....	91
8.11.2	Speech Function.....	92
8.12	PWM / DAC Function.....	93
8.12.1	PWM Function Block Diagram.....	93
8.12.2	DAC Function Block Diagram.....	94
8.12.3	PWM / DAC Function Registers.....	94
<b>9</b>	<b>Electrical Characteristic</b> .....	<b>95</b>
<b>10</b>	<b>Application Circuit</b> .....	<b>100</b>
<b>11</b>	<b>Instruction Set</b> .....	<b>102</b>
<b>12</b>	<b>Pad Diagram</b> .....	<b>105</b>

## Specification Revision History

Doc. Version	Revision Description	Date
0.0	Initial version	2002/09/25
0.1	<ol style="list-style-type: none"> <li>1. Modified the EPDZ as EPD.</li> <li>2. Modified the UART baud rate: Timer 0/2 as Timer 0/32.</li> <li>3. Added Port D.7~4 (SPI) and deleted PB.3, PB.4; PC.0, PC.1.</li> <li>4. Modified the LCD RAM map.</li> <li>5. Added PWM drive size selection in the Code Option.</li> </ol>	2002/10/02
0.2	<ol style="list-style-type: none"> <li>1. Added Code example for every function.</li> <li>2. Added PISEG, PJSEG and PKSEG in the Code Option.</li> <li>3. Added A/D operation in FAST mode.</li> <li>4. Modified the POST_ID register for LCD from LCDARH: LCDARL as LCDARL.</li> <li>5. Added Pin Assignment and Pad Diagram.</li> <li>6. Modified VOH and VOL of PB [1:0] as PWM output of the DC spec.</li> </ol>	2002/10/15 2002/11/21 2002/11/28 2003/01/17
2.0	<ol style="list-style-type: none"> <li>1. Redefined the special register description.</li> <li>2. Modified the code option description.</li> <li>3. Modified the code example.</li> <li>4. Added power-up and reset timing.</li> <li>5. Modified the INC and DEC Status affected.</li> <li>6. Modified the Strobe output ON-resistance.</li> </ol>	2003/11/10
2.1	<ol style="list-style-type: none"> <li>1. Modified the maximum system clock to 10MHz.</li> <li>2. SPI configuration example modified body name is EPD3330.</li> <li>3. Modified the LCD power control mode with Vout pin not connected to EM65168 Vout pin.</li> <li>4. Added Power Consumption Electrical Characteristic.</li> <li>5. Modified the Operating Temperature range to -10 ~ +60°C.</li> </ol>	2003/12/16
2.2	<ol style="list-style-type: none"> <li>1. Modified the data ROM table look up fixed to 3 cycles for the Code Option.</li> <li>2. Modified the 48×96 pixels driving application circuits.</li> </ol>	2004/05/18
2.3	<ol style="list-style-type: none"> <li>1. Deleted the ADPCM decoder/encoder function supported.</li> <li>2. Modified the Pull-up resistance of Port G and Port H</li> <li>3. Modified the DC Current Consumption in FAST mode.</li> <li>4. Added a Note on Not using TABPTRH (0Dh) Bit 6.</li> <li>5. Modified the A/D conversion with 4 channels general analog input.</li> </ol>	2005/08/01
2.4	<ol style="list-style-type: none"> <li>1. <a href="#">New Specification</a></li> <li>2. <a href="#">Added code example for Port H and Port G set input.</a></li> <li>3. <a href="#">Modified the Note about FA/D value, which when greater than 1.4MHz is invalid.</a></li> <li>4. <a href="#">Modified the A/D conversion operation mode.</a></li> </ol>	2005/09/20 2005/11/03



# 1 General Description

The **EPD3332** is an 8-bit RISC MCU which embedded a 10 bits SAR A/D converter with touch screen controller, an analog front end,  $32 \times 64$  LCD driver, two 8-bit timers and one 16-bit general timer with capture and event counter functions, IR generator, watchdog timer, SPI, UART, and four melody timers, a PWM and a current D/A. Besides, it has an embedded large size user RAM and program/data memory. It is suitable for educational learning tools application requiring high performance and low cost solution.

The MCU's core is ELAN's second generation RISC (RISC II) based IC. The core is specifically designed as a low power and portable device. It supports FAST, SLOW, and IDLE mode, as well as SLEEP mode for low power consumption application.

## IMPORTANT NOTES

- Do not use Register BSR (05h) Bit 7 ~ Bit 4.
- Do not use Register BSR1 (07h) Bit 7 ~ Bit4.
- Do not use Special Register (04h).
- Do not use Special Register (1Bh).
- Do not use Special Register (1Ch).
- Do not use Special Register (1Fh).
- Do not use Special Register (2Ah).
- Do not use Special Register (32h).
- Do not use Special Register (33h).
- Do not use Special Register (39h).
- Do not use Special Register (4Fh).
- Do not use LCD RAM Page 00 (40h~4Fh).
- Do not use LCD RAM Page 01 (40h~4Fh).
- Do not use LCD RAM Page 02 (40h~4Fh).
- Do not use LCD RAM Page 03 (40h~4Fh).
- Do not use LCD RAM Page 04 (40h~4Fh).
- Do not use Port B.3~4.
- Do not use Port C.0~1.
- Do not use Port D.0~3.
- Do not use JDNZ and JINZ at FSR1 (09h) special register.
- Do not use Register TABPTRH (0Dh) Bits 6, 5.

## 1.1 Applications

- Educational Learning Tools
- Kids PDA, Kids computer
- Electronics book
- Dictionary, Data Bank

---

## 2 Features

### 2.1 MCU Features

- 8 bit RISC MCU
- $8 \times 8$  multiplier with controllable signed or unsigned operation
- Operating voltage and speed: 10MHz ~ 9.83MHz @ 2.6V, 8MHz @ 2.4V
- One Instruction cycle time =  $2 \times$  System clock time
- Program ROM addressing: 32K words max.
- Data ROM addressing: 256K words max.
- 128 bytes un-banked RAM including special registers and common registers
- $16 \times 128$  bytes banked RAM
- Maximum of 128 stack levels for RAM stack
- Table Look Up function is fast and highly efficient when implemented with Repeat instruction
- Register-to-Register move instruction
- Compare and Branch in one instruction (2 cycles)
- Single Repeat function (256 repeat times max.)
- Decimal ADD & SUB instruction
- Full range CALL and JUMP capability (2 cycles)

### 2.2 Peripheral

- One input port (Port A) and 32 general I/O pins (Port B.7~5, Port B.2~0, Port C.7~2, Port D.7~4, Port G ~ Port H)
- 4-channel Melody/Speech Synthesizer
- 32 COM  $\times$  64 SEG LCD driver embedded or supplied with 96 segments for external LCD driver that is compatible with EM65168 which has 48 COM  $\times$  (96+32) SEG.
- 16-bit timer (Timer 0) with capture and event counter functions
- 8-bit timer (Timer 1) with wake-up function

- 8-bit timer (Timer 2) as beat counter for Melody function
- 8-bit IR generator
- 8-bit PWM and a current D/A for melody and speech application
- 8-bit Watchdog Timer
- 10 bits resolution SAR A/D converter with 4 channels general analog input and 2 channels for touch panel application
- Key I/O function with 112 keys maximum
- SPI (Serial Peripheral Interface)
- UART (Universal Asynchronous Receiver and Transmitter)

### **2.3 Internal Specification**

- Watchdog Timer with its own on-chip RC oscillator
- MCU mode: SLEEP MODE, IDLE MODE, SLOW MODE, and FAST MODE
- Supports RC oscillation and crystal oscillation for system clock
- PLL is turned on at FAST mode, and controlled by PEN bit when MCU is in SLOW mode and IDLE mode
- MCU Wake-up function includes input wake up, Timer 1 wake up, touch panel wake up, SPI wake up, and A/D wake up
- MCU interrupt function includes Input port interrupt, touch panel interrupt, Capture interrupt, speech timer interrupt, Timer interrupt (Timers 0~2), A/D interrupt, SPI interrupt and UART interrupt
- MCU reset function includes power-on reset, RSTB pin reset, and Watchdog timer reset

### **2.4 ELAN Software Support (Option)**

- Hand writing recognition
- LCD display
- 4-channel Melody or 3-channel Melody + 1-channel Speech
  
- Package: 143 pins chip form

### 3 Block Diagram

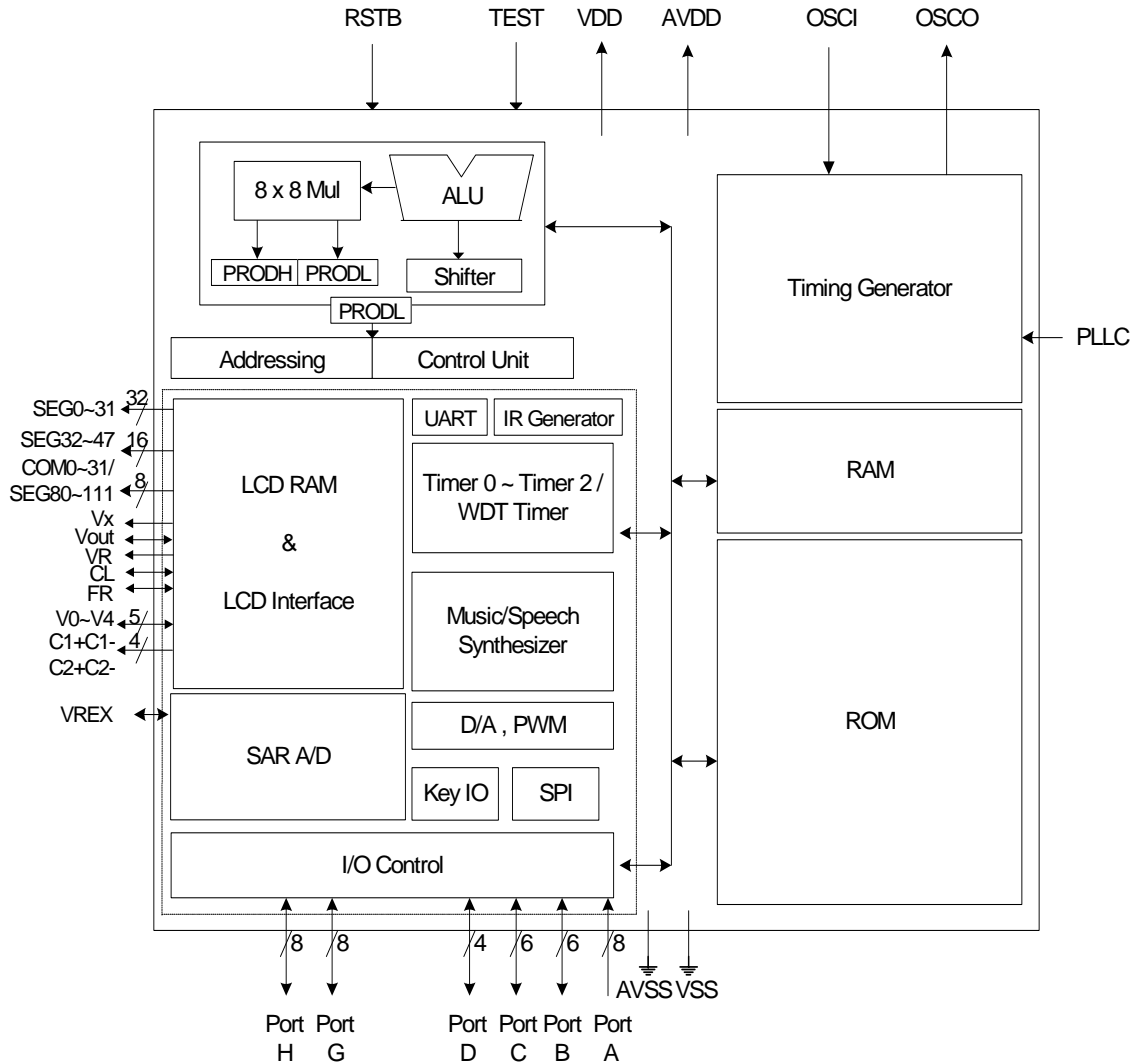

## 4 Pin Assignment

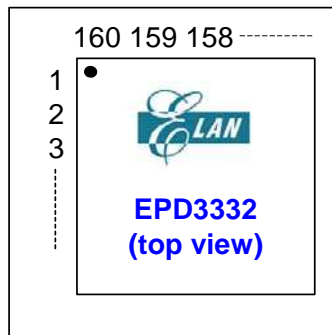

No.	Pin Name	No.	Pin Name	No.	Pin Name	No.	Pin Name
1	N.C.	41	N.C	81	COM17/SEG81	121	N.C.
2	N.C.	42	N.C	82	COM16/SEG80	122	N.C.
3	COM8/SEG103	43	N.C	83	PH.7 (SEG63)	123	N.C.
4	COM9/SEG102	44	N.C	84	PH.6 (SEG62)	124	N.C.
5	COM10/SEG101	45	PC.3 (ADIN5)	85	PH.5 (SEG61)	125	SEG25
6	COM11/SEG100	46	PC.4 (ADIN4/YP)	86	PH.4 (SEG60)	126	SEG24
7	COM12/SEG99	47	PC.5 (ADIN3/XP)	87	PH.3 (SEG59)	127	SEG23
8	COM13/SEG98	48	PC.6 (YN)	88	PH.2 (SEG58)	128	SEG22
9	COM14/SEG97	49	PC.7 (XN)	89	PH.1 (SEG57)	129	SEG21
10	COM15/SEG96	50	VREX	90	PH.0 (SEG56)	130	SEG20
11	VOUT	51	VDD	91	PG.7 (SEG55)	131	SEG19
12	Vx	52	PD.7 (SPISDI)	92	PG.6 (SEG54)	132	SEG18
13	VR	53	PD.6 (SPISDO)	93	PG.5 (SEG53)	133	SEG17
14	V1	54	PD.5 (SPISCK)	94	PG.4 (SEG52)	134	SEG16
15	V2	55	PD.4 (SPISS)	95	PG.3 (SEG51)	135	SEG15 (Strobe 15)
16	V3	56	PA.7	96	PG.2 (SEG50)	136	SEG14 (Strobe 14)
17	V4	57	PA.6	97	PG.1 (SEG49)	137	SEG13 (Strobe 13)
18	C1+	58	PA.5	98	PG.0 (SEG48)	138	SEG12 (Strobe 12)
19	C1-	59	PA.4	99	SEG47	139	SEG11 (Strobe 11)
20	C2+	60	PA.3	100	SEG46	140	SEG10 (Strobe 10)
21	C2-	61	PA.2	101	SEG45	141	SEG9 (Strobe 9)
22	V0	62	PA.1	102	SEG44	142	SEG8 (Strobe 8)
23	FR	63	PA.0	103	SEG43	143	SEG7 (Strobe 7)
24	CL	64	COM31/SEG95	104	SEG42	144	SEG6 (Strobe 6)
25	TEST	65	COM30/SEG94	105	SEG41	145	SEG5 (Strobe 5)
26	PLL	66	COM29/SEG93	106	SEG40	146	SEG4 (Strobe 4)
27	OSCI	67	COM28/SEG92	107	SEG39	147	SEG3 (Strobe 3)
28	OSCO	68	COM27/SEG91	108	SEG38	148	SEG2 (Strobe 2)
29	RSTB	69	COM26/SEG90	109	SEG37	149	SEG1 (Strobe 1)
30	VDD	70	COM25/SEG89	110	SEG36	150	SEG0 (Strobe 0)
31	PB.0 (VO2)	71	COM24/SEG88	111	SEG35	151	COM0 (SEG111)
32	PB.1 (VO1/DAO)	72	COM23/SEG87	112	SEG34	152	COM1 (SEG110)
33	VSS	73	COM22/SEG86	113	SEG33	153	COM2 (SEG109)
34	PB.2 (IROT)	74	COM21/SEG85	114	SEG32	154	COM3 (SEG108)
35	PB.5 (EVIN/CPIN)	75	COM20/SEG84	115	SEG31	155	COM4 (SEG107)
36	PB.6 (UTXD)	76	COM19/SEG83	116	SEG30	156	COM5 (SEG106)
37	PB.7 (URXD)	77	COM18/SEG82	117	SEG29	157	COM6 (SEG105)
38	PC.2 (ADIN6)	78	N.C.	118	SEG28	158	COM7 (SEG104)
39	N.C.	79	N.C.	119	SEG27	159	N.C.
40	N.C.	80	N.C.	120	SEG26	160	N.C.

## 5 Pin Description

Name	I/O/P Type	Description
VDD VSS	P	Digital power supply, the range is from 2.2V to 3.6V. Connect to VSS through the capacitors (0.1μF)
AVDD AVSS	P	Analog power supply, the range is from 2.2V to 3.6V. Connect to VSS through the capacitors (0.1μF)
RSTB	I	System reset input with built-in pull-up resistor (100KΩ Typical) Low: RESET asserted High: RESET released
TEST	I	Normally connect to VSS, reserved for testing
OSCI/RC OSCO	I O	RC or Crystal selection by Code Option 32768 Hz oscillator pins. Connect to VSS through the capacitors (20pF) RC oscillator connector pin. Connect to VDD through a resistor (2MΩ)
PLLC	I	PLL capacitor connector pin. Connect to VSS through the capacitors (0.047μF)
VREX	I/O	External or internal reference voltage for A/D converter. Connect to VSS through the capacitors (0.1μF)
Vx	-	Clamping circuit output voltage. Ext. C (0.1μF) to VSS
Vout	-	Charge pump output voltage. Ext. C (0.22μF) to VSS
VR	-	V0 voltage adjusting pin
V0~V4	O	LCD bias pin. Ext. C (0.1μF) to VSS
C1+, C1-, C2+, C2-	-	Charge pump capacitor (0.1μF)
COM0~COM31/ SEG80~SEG111	O	LCD common/segment signal output pin Multiplexed: Common and segment pin
SEG0~SEG47	O	LCD segment signal output pin (SEG0~SEG15 are shared with key strobe)
CL	I/O	Display clock input/output pin
FR	I/O	LCD frame signal input/output pin
Port A	I	General Input port for special functions, i.e., Wake-up and Interrupt Bit 7: ON key input Bit 6~0: Key matrix input pins
Port B (7~5, 2~0)	I/O I O I O O O	General Input/Output port Bit 7: UART Rx pin Bit 6: UART Tx pin Bit 5: Event counter/Capture input pin Bit 2: IR output pin Bit 1: PWM or Current D/A output pin Bit 0: PWM output pin
Port C (7~2)	I/O O O I I I I	General Input/Output port Bit 7: Touch screen X direction negative pin Bit 6: Touch screen Y direction negative pin Bit 5: Touch screen X direction positive pin & A/D input Channel 3 Bit 4: Touch screen Y direction positive pin & A/D input Channel 4 Bit 3: A/D input Channel 5 Bit 2: A/D input Channel 6
Port D (7~4)	I/O I O I/O I	General Input/Output port Bit 7: Serial data input pin Bit 6: Serial data output pin Bit 5: Serial clock input/output pin Bit 4: /Slave Select pin
Port G	I/O O	General Input/Output port SEG 55~48: LCD segment signal output pins
Port H	I/O O	General Input/Output port SEG 63~56: LCD segment signal output pins

## 6 Code Option

Located at the address 0x000C~0x000F of the Program ROM:

- Oscillator (OSCSEL): Select "RC" oscillator or "Crystal" oscillator
- Initial mode after reset: Select "Slow" mode or "Fast" mode
- Port C.7 function selection bit: Select "XN for touch panel" or "General I/O function"
- Port C.6 function selection bit: Select "YN for touch panel" or "General I/O function"
- Port C.5 function selection bit: Select "XP for touch panel/ADIN3" or "General I/O function"
- Port C.4 function selection bit: Select "YP for touch panel/ADIN4" or "General I/O function"
- Port C.3 function selection bit: Select "ADIN5" or "General I/O function"
- Port C.2 function selection bit: Select "ADIN6" or "General I/O function"
- DAC and PWM function selection bits:

DAC or PWM Function Selection	Port B.0 and Port B.1 Function
DAC is used	Port B.1 is DAO for D/A, Port B.0 is General I/O
PWM is used	Port B.1 is VO1 and Port B.0 is VO2 for PWM
DAC and PWM are not for use	General I/O

- Duty Ratio: Maximum Duty Ratio Option

COM 8-15/SEG 103-96; COM 16-23/SEG 87-80 & COM 24-31/SEG 95-88 status setting

Duty Ratio	Display Size (max.)	Common Driver Used				
		COM 0~7/ SEG 104~111		COM 8~15/ SEG 103~96	COM 16~23/ SEG 87~80	COM 24~31/ SEG 95~88
1/4	88 × 4	COM 0~3	Unused	SEG103~96	SEG87~80	SEG95~88
1/8	88 × 8	COM 0~7		SEG103~96	SEG87~80	SEG95~88
1/9	80 × 9	COM 0~8		Prohibited	SEG87~80	SEG95~88
1/11	80 × 11	COM 0~10		Prohibited	SEG 87~80	SEG 95~88
1/16	80 × 16	COM 0~15			SEG 87~80	SEG 95~88
1/24	72 × 24	COM 0~23				SEG 95~88
1/32	64 × 32	COM 0~31				
1/48	128 × 48	SEG 64~95 *				

\* The COM pins are supplied as SEG and combined with EM65168A 32 SEG pins, the total is 128 SEG.



## 7 Function Description

### 7.1 Reset Function

A RESET can be caused by:

- Power-on voltage detector reset and power-on reset
- WDT timeout
- RSTB pin pull low

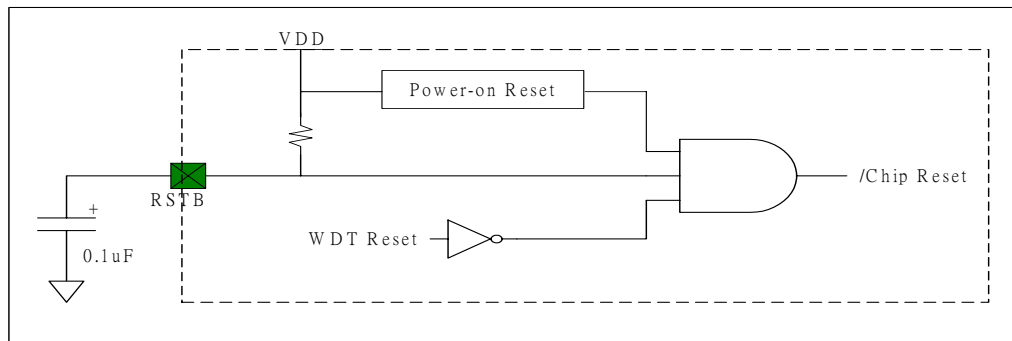

Fig 7-1 On-chip RESET Circuit

#### 7.1.1 Power-up and Reset Timing

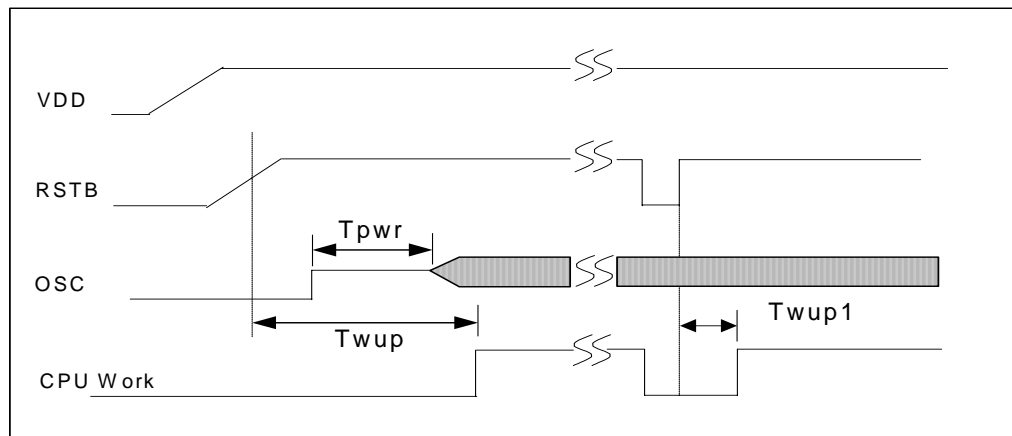

Fig 7-2 Power-up and RESET Timing

Symbol	Characteristics	Min.	Typ.	Max.	Unit
Tpwr	Oscillator start up time	100	226	300	ms
Twup	CPU warm up time	260	340	550	ms
Twup1	CPU reset time	18	22	44	ms



■ STATUS (R0Fh)

Bit 7	Bit 6	Bit 5	Bit 4	Bit 3	Bit 2	Bit 1	Bit 0
/TO	/PD	SGE	SLE	OV	Z	DC	C

- Bit 0 (C):** Carry flag or inverse of Borrow flag (B)  
When in SUB operation, borrow flag is indicated by the inverse of carry bit ( $B = /C$ )
- Bit 1 (DC):** Auxiliary carry flag
- Bit 2 (Z):** Zero flag
- Bit 3 (OV):** Overflow flag. Use in signed operation when Bit 6 carry into or borrow from a signed bit (Bit 7).
- Bit 4 (SLE):** Computation result is less than or equal to zero (Negative value) after a signed arithmetic. It is only affected by a HEX arithmetic instruction.
- Bit 5 (SGE):** Computation result is greater than or equal to zero (Positive value) after a signed arithmetic. It is only affected by a HEX arithmetic instruction.

**NOTE**

1. When  $OV=1$  after a signed arithmetic, user can check the SGE and SLE bits to determine whether an overflow (carry into a signed bit) or underflow (borrow from a signed bit) occurs.  
 $OV=1$  and  $SGE=1 \rightarrow$  overflow occurs  
 $OV=1$  and  $SLE=1 \rightarrow$  underflow occurs
2. When overflow occurs, user should clear the MSB of the Accumulator in order to get the correct value.  
 When underflow occurs, user should set the MSB of the Accumulator in order to get the correct value.

**Example 1.** ADD a positive value to another positive value, and ACC signed bit will be affected.

```
MOV ACC, #60h ; Signed number +60h.
ADD ACC, #70h ; +60h ADD WITH +70h.
```

**After instruction:** ACC = 0D0h

SGE=1, means the result is greater than or equal to 0 (positive value)

OV=1, means the result is carry into a signed bit (Bit 7), overflow occurs.

**Correct the signed bit:** ACC = 50h (Clear the signed bit)

The actual result= +80h (OV=1) + 50h = +0D0h

**Example 2.** SUB a positive value from a negative value, and ACC signed bit will be affected.

```
MOV ACC, #50h ; Signed number +50h.
SUB ACC, #90h ; +50h SUB from -70h (Signed number of 90h)
```

**After instruction:** ACC = 40h

SLE=1, means the result is less than or equal to 0 (negative value)

OV=1, means the result is borrow from a signed bit (Bit 7), underflow occurs.

**Correct the signed bit:** ACC = 0C0h (Set the signed bit)

The actual result = -80h (OV=1) + 0C0h (signed number of 0C0h) = 40h

**Bit 6 (/PD):** Reset to 0 when entering SLEEP mode. Set to 1 by “WDTC” instruction, power-on reset or during a Reset pin low condition.

**Bit 7 (/TO):** Reset to 0 during WDT time out reset. Set to 1 by “WDTC” instruction, entering SLEEP MODE, power-on reset or during a Reset pin low condition.

When a reset occurs, the special function register will be reset to its initial value except for the /TO and /PD bits of the STATUS register.

Bit 7 (/TO)	Bit 6 (/PD)	Event
0	0	WDT time out reset from SLEEP mode
0	1	WDT time out reset (not SLEEP mode)
1	0	Reserved
1	1	Power on or RSTB pin low condition

### 7.1.2 Register Initial Values

**Special Register:**

Addr.	Name	Initial Value	Addr.	Name	Initial Value
00h	INDF0	---- <sup>1</sup>	10h	TRL2	uuuu uuuu
01h	FSR0	0000 0000	11h	PRODL	uuuu uuuu
02h	PCL	0000 0000	12h	PROLH	uuuu uuuu
03h	PCM	-000 0000	13h	ADOTL	0-0- -0uu
04h	(Reserved)	----	14h	ADOTH	uuuu uuuu
05h	BSR	---- 0000	15h	UARTTX	xxxx xxxx
06h	STKPTR	0000 0000	16h	UARTRX	xxxx xxxx
07h	BSR1	---- 0000	17h	Port A	xxxx xxxx
08h	INDF1	---- <sup>1</sup>	18h	Port B	xxx- -xxx
09h	FSR1	1000 0000	19h	Port C	xxxx xx--
0Ah	ACC	xxxx xxxx	1Ah	Port D	xxxx ----
0Bh	TABPTRL	0000 0000	1Bh	Reserved	----
0Ch	TABPTRM	0000 0000	1Ch	Reserved	----
0Dh	TABPTRH	0-0 0000	1Dh	Port G	xxxx xxxx
0Eh	CPUCON	0-0 000c <sup>2</sup>	1Eh	Port H	xxxx xxxx
0Fh	STATUS	cuxx xxxx <sup>3</sup>	1Fh	Reserved	----



## 7.2 Oscillator System

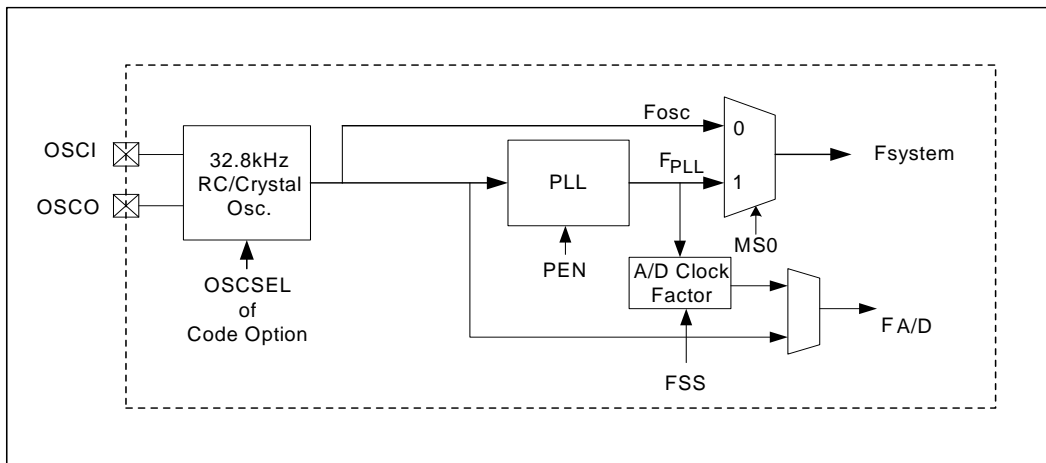

Fig 7-3 Oscillator System Function Block Diagram

### 7.2.1 32.768kHz Crystal or 32.8kHz RC

For the 32.8kHz RC oscillator, connect a 2MΩ pull-up resistor to OSCI pin and the OSCO pin should be floating.

For the 32.768kHz Crystal oscillator, connect the crystal between OSCI and OSCO pins. Then connect the OSCI and OSCO pins to ground through a 20pF capacitor.

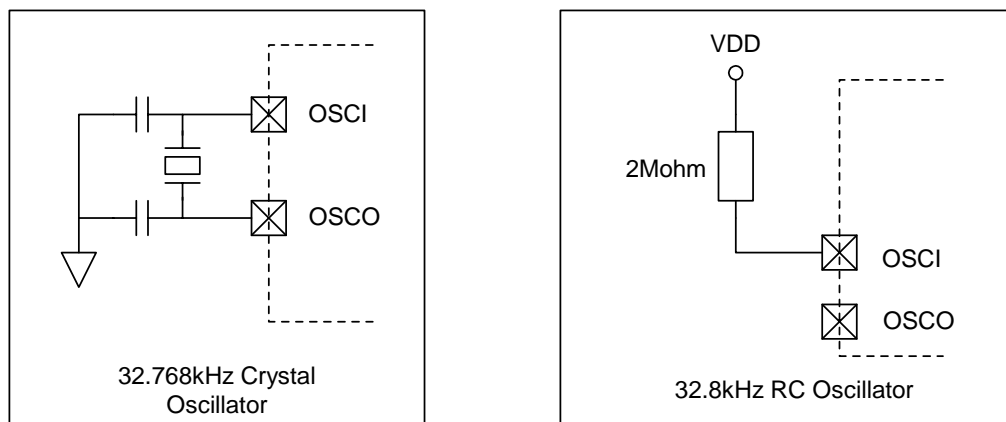

Fig 7-4 Crystal and RC Oscillator Circuit Diagram

### 7.2.2 Phase Locked Loop (PLL)

- **PLL F (R3Ch):** Store the actual PLL frequency value. It is used to check whether the PLL frequency is stable or not.

$$F_{actual} = 2 \times PLLF \times F_{OSC}$$

- **PFS (R20h):** Target PLL frequency select register. System clock can be fine tuned from 0.983MHz to 10MHz. The initial value of the PFS register after a chip reset will be set to "20h" (F<sub>PLL</sub>=2.097 MHz)

$$F_{target} = 2 \times PFS \times F_{OSC}$$

PFS Register	Ftarget (MHz)	PFS Register	Ftarget (MHz)
0~14	N.A. <sup>1</sup>	92	6.029
		107	7.012
15	0.983	122	7.995
31	2.032	137	8.978
46	3.015	150	9.83 <sup>2</sup>
61	3.998	153	10.027
76	4.981	154 ~	N.A. <sup>1</sup>

<sup>1</sup> PFS=0~14 and > 153 are not available.

<sup>2</sup> When UART is enabled, the system clock should be 9.83MHz (PFS=150).

The table is based on 32.768kHz oscillator frequency.

The Maximum range of PLL is from 9.83MHz ~ 10.027MHz.

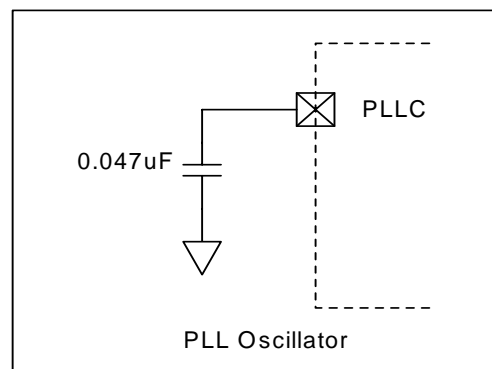

Fig 7-5 PLL Oscillator Circuit Diagram

### 7.3 MCU Operation Mode

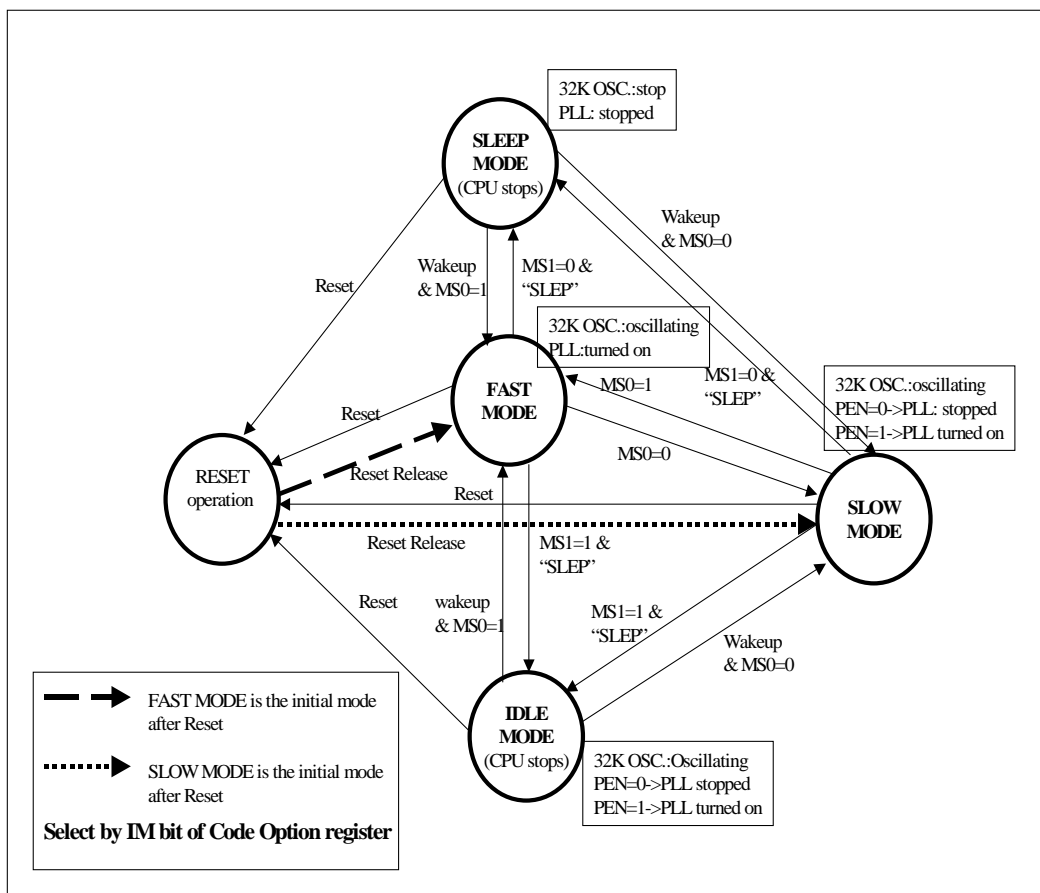

Fig. 7-6 Operation Block Diagram

#### MCU Mode with Function Table:

Device \ Mode	SLEEP	IDLE	SLOW	FAST
OSC (32.768kHz)	×	√	√	√
Fsystem	×	×	From OSC	From PLL
PLL	×	√	√	√
A/D conversion	×	√ <sup>2</sup>	√	√
Timers 0~2, IR generator	×	√	√	√
INT	×	×	√	√
SPI	√ (slave)	√ (slave)	√	√
UART	×	×	×	√
Melody Synthesizer	×	×	×	√
PWM, current D/A	×	×	√	√

**Legend:** "√" = function is available if enabled "×" = function is Not available

<sup>1</sup> Interrupt flag will be recorded but not executed until the MCU wakes up.

<sup>2</sup> It is recommended to operate the A/D converter in IDLE mode to lower the noise couple from the MCU clock.

■ CPUCON (R0Eh):

Bit 7	Bit 6	Bit 5	Bit 4	Bit 3	Bit 2	Bit 1	Bit 0
PEN	-	-	SMCAND	SMIER	GLINT	MS1	MS0

SLEEP MODE: When MS1 bit is set to '0' and "SLEP" instruction is executed, the MCU will enter SLEEP mode.

IDLE MODE: When MS1 bit is set to '1' and "SLEP" instruction is executed, the MCU will enter IDLE mode.

SLOW MODE: When MS0 bit is set to '0', the MCU will enter SLOW mode.

FAST MODE: When MS0 bit is set to '1', the MCU will enter FAST mode.

PLL enable: It is only effective when the MCU is in IDLE mode or SLOW mode.

MCU Mode	PEN Bit	PLL On/Off
SLEEP	×	Off
IDLE/SLOW	0	Off
	1	On
FAST	×	On

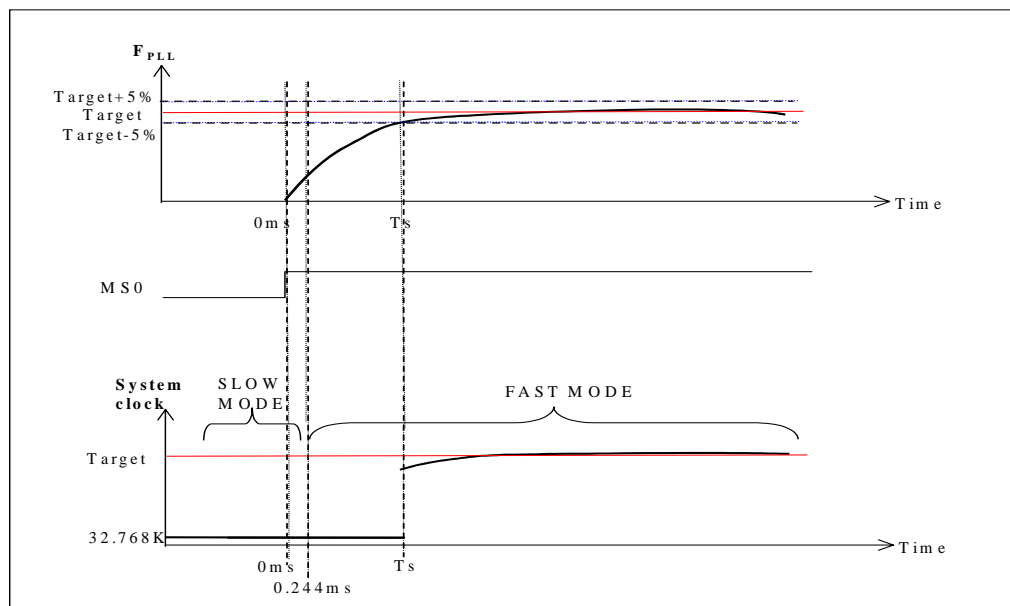

Fig. 7-7 MCU Operation Timing Diagram

**NOTE**

1. Switch from Slow mode to Fast mode at Time=0ms
2. The System clock will switch to FPLL after 8 oscillation clocks, and the system clock will then increase to about hundreds of kHz.
3. The PLL frequency will be stable ( $\pm 5\%$ ) at Time=Ts (2ms~5ms).

## 7.4 Wake-up Function

Mode \ Device	SLEEP	IDLE	SLOW	FAST
I/O wake up	√	√	x	x
Touch panel wake up	√	√	x	x
Timer1 wake up	x	√	x	x
A/D wake up	x	√	x	x
SPI wake up	√ (Slave)	√ (Slave)	x	x

**Legend:** √ = Function is available if enabled      x = Function is NOT available

Flowchart:

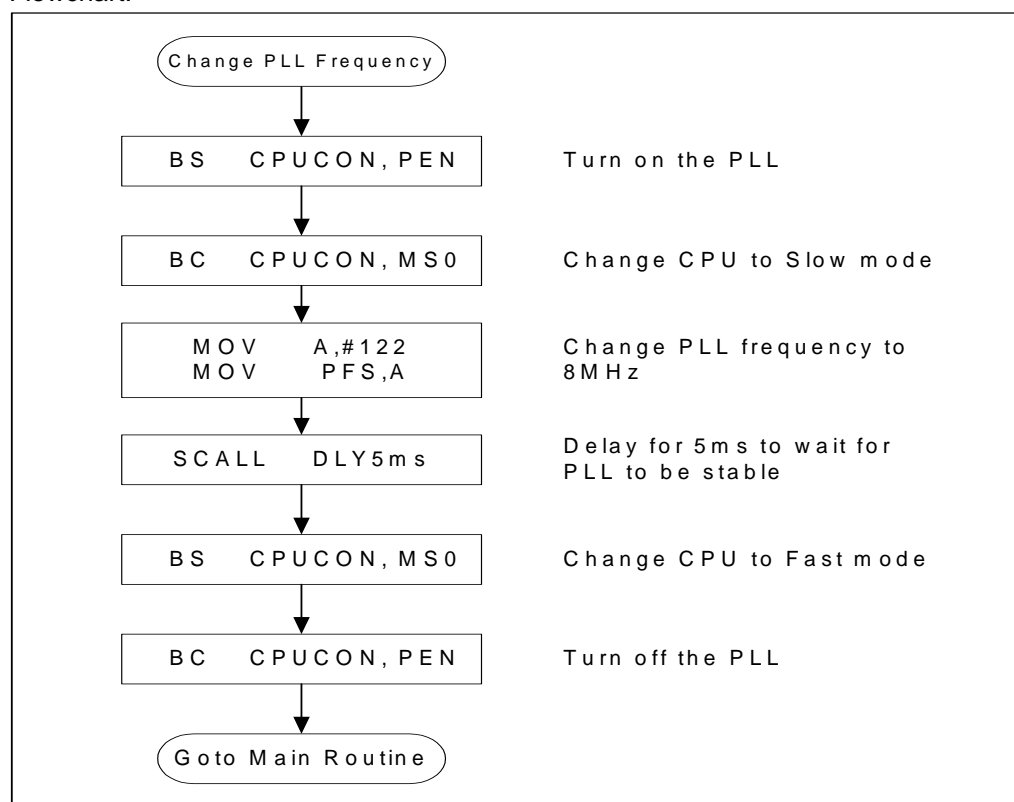

### Code Example:

```

Entry FAST mode
MOV    A, #122    ; 8MHz
MOV    PFS, A
BS     CPUCON, MS0
  
```

```

Entry SLOW mode
BC     CPUCON, MS0
  
```

```

Entry IDLE mode
BS     CPUCON, MS1
SLEP
NOP
  
```

```

Entry SLEEP mode
BC     CPUCON, MS1
SLEP
NOP
  
```

## 7.5 Interrupt

When an interrupt occurs, the **GLINT** bit of the CPUCON register is reset to 0, which disables all interrupts, including Level 1 ~ Level 5. Setting this bit to 1 can enable all un-mask interrupts.

Interrupt Level	Interrupt Source	Start Address	Remark
	RESET	0x00000	
Level 1	Input Port	0x00002	PAINT, PIRQB
Level 2	Capture	0x00004	CPIF
Level 3	Speech Timer	0x00006	SPHTI
Level 4	Timers 0~2	0x00008	TMR0I, TMR1I, TMR2I
Level 5	Peripheral	0x0000A	UERRI, UTXI, URXI, ADIF, SRBFI

### Code Example:

```

; ***** Reset program
ResetSEG  CSEG      0X00
    LJMP  MSTART   ;(0X00) Initialize
    LJMP  INPTINT  ;(0X02) Input Port and Touch Panel INT
    LJMP  CAPINT   ;(0X04) Capture Input INT
    LJMP  SPHINT   ;(0X06) Speech Timer INT
    LJMP  TIMERINT ;(0X08) Timer-0,1,2 INT
    LJMP  PERIPH   ;(0X0A) Peripheral INT
PgmSEG    CSEG      0X20

;---Push interrupt register
PUSH:
    MOV   AccBuf,A
    MOVPR StatusBuf,Status
    RET

;---POP interrupt register
POP:
    MOVRP Status,StatusBuf
    MOV   A,AccBuf
    RETI

```

### 7.5.1 Input Port A Interrupt

1. Port A Interrupt (Falling edge trigger): Port A is used as external interrupt/wake-up input.
2. Touch Panel Interrupt (Level trigger): When Port C.7~Port C.4 (X+, X-, Y+ & Y-) are connected to touch panel input pins and touch panel is touched, PIRQB interrupt occurs.

### Code Example:

```

;===Input Port And Touch Panel Interrupt
INPTINT:
    S0CALL  PUSH
    JBC     ADCON,PIRQB,toTPINT
    TEST    PAINTSTA
    JBC     STATUS,F_Z,toPAINT
    SJMP   POP

;---Touch panel interrupt
toTPINT:
    :
    SJMP   POP
;---Port A interrupt
toPAINT:
    CLR    PAINTSTA
    :
    SJMP   POP

```

### 7.5.2 Capture Input Interrupt

The Capture function is used to capture an input event at rising to falling edge, falling to rising edge, rising to rising edge, or falling to falling edge. When every event input edge is detected, a Capture interrupt occurs.

**Code Example:**

```

; === Capture Input Interrupt
CAPINT:
    SOCALL    PUSH
    JBS       INTSTA,CPIF,toCAPINT
    SJMP      POP
; --- Capture input interrupt
toCAPINT:
    BS        INTSTA,CPIF
    :
    SJMP      POP
    
```

### 7.5.3 Speech Timer Interrupt

Speech Timer is an 11-bit timer for time counting. When the counting value of the Speech Timer underflows, an interrupt occurs and the SPHTRL value will be reloaded to counting value.

**Code Example:**

```

; === Speech Timer Interrupt
SPHINT:
    SOCALL    PUSH
    JBS       PHTCON,SPHTI,toSPHINT
    SJMP      POP
; --- To speech timer interrupt
toSPHINT:
    BC        SPHTCON,SPHTI
    :
    SJMP      POP
    
```

### 7.5.4 Timer 0, Timer 1, and Timer 2 Interrupts

1. Timer 0 Interrupt: Timer 0 is a 16-bit timer for general time counting. When the counting value is larger than TRL0H : TRL0L value, a Timer 0 interrupt occurs.
2. Timer 1 Interrupt: Timer 1 is an 8 bit-timer for time counting and wake-up function. When the counting value of Timer 1 underflows, an interrupt occurs and the TRL1 value will be reloaded to counting value.
3. Timer 2 Interrupt: Timer 2 is an 8-bit timer for time counting. When the counting value of Timer 2 underflows, an interrupt occurs and the TRL2 value will be reloaded to counting value.

**Code Example:**

```

; === Timer-0,1,2 Interrupt
TIMERINT:
    SOCALL    PUSH
    JBS       INTSTA,TMR0I,toTM0INT
    JBS       INTSTA,TMR1I,toTM1INT
    JBS       INTSTA,TMR2I,toTM2INT
    SJMP      POP
; --- Timer 0 Interrupt
toTM0INT:
    BC        INTSTA,TMR0I
    :
    SJMP      POP
; --- Timer 1 Interrupt
toTM1INT:
    BC        INTSTA,TMR1I
    :
    SJMP      POP
; --- Timer 2 Interrupt
toTM2INT:
    BC        INTSTA,TMR2I
    :
    SJMP      POP
    
```



### 7.5.5 Peripheral Interrupt

1. A/D (Analog to Digital converter) Interrupt: A/D is used to convert analog input signal to digital output bits. When the conversion is completed, an A/D interrupt occurs.
2. UERRI Interrupt: UART receiving error interrupt
3. UTXI Interrupt: UART transfer buffer empty interrupt
4. URXI Interrupt: UART receiver buffer full interrupt
5. SRBFI Interrupt: SPI read buffer full interrupt

**Code Example:**

```

; === Peripheral Interrupt
PERIPH:
    SOCALL    PUSH
    JBS      INTSTA,ADIF ,toADINT
    JBS      INTSTA,UERRI ,toUERRINT
    JBS      INTSTA,UTXI ,toUTXINT
    JBS      INTSTA,URXI ,toURXINT
    JBS      SPISTA,SRBFI ,toSPINT
    SJMP     POP
;--A/D interrupt
toADINT:
    BC      INTSTA,ADIF
    :
    SJMP    POP
;--UART Receiving Error Interrupt
toUERRINT:
    BC      INTSTA,UERRI
    :
    SJMP    POP
;--UART Tx Buffer Full Interrupt
toUTXINT:
    BC      INTSTA,UTXI
    :
    SJMP    POP
;--UART Rx Buffer Full Interrupt
toURXINT:
    BC      INTSTA,URXI
    :
    SJMP    POP
;--SPI Interrupt
toSPINT:
    BC      SPISTA,SRBFI
    :
    SJMP    POP
    
```

### 7.6 Program ROM Map

8K word × 4 Segments = 32K words	
Address	Segment
0000h   000Bh	Interrupt Vector (12 words)
000Ch   000Fh	Code Option (4 words)
0010h   001Fh	Test Program (16 words)
0020h   3FFFh	Segment 0   Segment 1
4000h   7FFFh	Segment 2   Segment 3

## 7.7 Data ROM Map

Maximum Size is 256K words	
Address	
100000h   13FFFFh	Data ROM (4M bits)

## 7.8 RAM Map Register (RAM Size: 128 Bytes + 16 Banks × 128 Bytes = 2176 Bytes)

◇ Special and Control Register of RAM:

**Legend:** "R" = Readable bit    "W" = Writable bit    "-" = unimplemented, read as "0"

Addr.	Register Name	Bit 7	Bit 6	Bit 5	Bit 4	Bit 3	Bit 2	Bit 1	Bit 0	
0	INDF0	R/W Indirect Addressing Pointer 0								
1	FSR0	R/W File Select Register 0 for INDF0								
2	PCL	R/W PC7	R/W PC6	R/W PC5	R/W PC4	R/W PC3	R/W PC2	R/W PC1	R/W PC0	
3	PCM	-	R/W PC14	R/W PC13	R/W PC12	R/W PC11	R/W PC10	R/W PC9	R/W PC8	
4	(Reserved)	-								
5	BSR	-				R/W Bank Select Register for INDF0 & General RAM				
6	STKPTR	R/W Stack Pointer								
7	BSR1	-				R/W Bank Select Register 1 for INDF1				
8	INDF1	R/W Indirect Addressing Pointer 1								
9	FSR1	R 1	R/W File Select Register 1 for INDF1							
A	ACC	R/W Accumulator								
B	TABPTRL	R/W Table Pointer Low								
C	TABPTRM	R/W Table Pointer Middle								
D	TABPTRH	R/W	-	-	R/W	R/W	R/W	R/W	R/W	
		Table Pointer High								
E	CPUCON	R/W PEN	-	-	R/W SMCAND	R/W SMIER	R/W GLINT	R/W MS1	R/W MS0	



Addr.	Register Name	Bit 7	Bit 6	Bit 5	Bit 4	Bit 3	Bit 2	Bit 1	Bit 0
F	STATUS	R /TO	R /PD	R/W SGE	R/W SLE	R/W OV	R/W Z	R/W DC	R/W C
10	TRL2	R/W Timer 2 Reload Register							
11	PRODL	R/W Multiplier Product Low							
12	PRODH	R/W Multiplier Product High							
13	ADOTL	R/W WDTEN	–	R/W ADWKEN	–	–	R/W FSS	R ADOT1	R ADOT0
14	ADOTH	R ADOT9	R ADOT8	R ADOT7	R ADOT6	R ADOT5	R ADOT4	R ADOT3	R ADOT2
15	UARTTX	W TB7	W TB6	W TB5	W TB4	W TB3	W TB2	W TB1	W TB0
16	UARTRX	R RB7	R RB6	R RB5	R RB4	R RB3	R RB2	R RB1	R RB0
17	Port A	R A.7	R A.6	R A.5	R A.4	R A.3	R A.2	R A.1	R A.0
18	Port B	R/W B.7	R/W B.6	R/W B.5	–	–	R/W B.2	R/W B.1	R/W B.0
19	Port C	R/W C.7	R/W C.6	R/W C.5	R/W C.4	R/W C.3	R/W C.2	–	–
1A	Port D	R/W D.7	R/W D.6	R/W D.5	R/W D.4	–			
1B	(Reserved)	–							
1C	(Reserved)	–							
1D	Port G	R/W G.7	R/W G.6	R/W G.5	R/W G.4	R/W G.3	R/W G.2	R/W G.1	R/W G.0
1E	Port H	R/W H.7	R/W H.6	R/W H.5	R/W H.4	R/W H.3	R/W H.2	R/W H.1	R/W H.0
1F	(Reserved)	–							
20	PFS	R/W Target PLL Frequency Selection Register							
21	STBCON	R/W UINVEN	R/W /SCAN	R/W BitST	R/W ALL	R/W STB3	R/W STB2	R/W STB1	R/W STB0
22	INTCON	R/W CPIE	R/W ADIE	R/W URXIE	R/W UTXIE	R/W UERRIE	R/W TMR2IE	R/W TMR1IE	R/W TMR0IE
23	INTSTA	R/W CPIF	R/W ADIF	R/W URXI	R/W UTXI	R/W UERRI	R/W TMR2I	R/W TMR1I	R/W TMR0I



Addr.	Register Name	Bit 7	Bit 6	Bit 5	Bit 4	Bit 3	Bit 2	Bit 1	Bit 0
24	TRL0L	R/W							
		Timer 0 Reload Low Byte Register							
25	TRL0H	R/W							
		Timer 0 Reload High Byte Register							
26	TRL1	R/W							
		Timer 1 Reload Register							
27	TR01CON	R/W	R/W	R/W	R/W	R/W	R/W	R/W	R/W
		T1WKEN	T1EN	T1PSR1	T1PSR0	IREN	T0CS	T0PSR1	T0PSR0
28	TR2CON	R/W	R/W	R/W	R/W	R/W	R/W	R/W	R/W
		IRPSR1	IRPSR0	T0FNEN1	T0FNEN0	T2EN	T2CS	T2PSR1	T2PSR0
29	TRLIR	R/W							
		IR Reload Register							
2A	(Reserved)	-							
2B	POST_ID		R/W	R/W	R/W		R/W	R/W	R/W
		-	LCD_ID	FSR1_ID	FSR0_ID	-	LCDPE	FSR1PE	FSR0PE
2C	ADCON	R/W	R/W	R/W	R	R/W	R/W	R/W	R/W
		DET	VRS	ADEN	PIROB	S/DB	CHS2	CHS1	CHS0
2D	PAINTEN	R/W	R/W	R/W	R/W	R/W	R/W	R/W	R/W
		PA7IE	PA6IE	PA5IE	PA4IE	PA3IE	PA2IE	PA1IE	PA0IE
2E	PAINTSTA	R/W	R/W	R/W	R/W	R/W	R/W	R/W	R/W
		PA7I	PA6I	PA5I	PA4I	PA3I	PA2I	PA1I	PA0I
2F	PAWAKE	R/W	R/W	R/W	R/W	R/W	R/W	R/W	R/W
		WKEN7	WKEN6	WKEN5	WKEN4	WKEN3	WKEN2	WKEN1	WKEN0
30	UARTCON	W	R/W	R/W	R/W	R/W	R/W	R	R/W
		TB8	UMODE1	UMODE0	BRATE2	BRATE1	BRATE0	UTBE	TXE
31	UARTSTA	R	R/W	R/W	R/W	R/W	R/W	R	R/W
		RB8	EVEN	PRE	PRERR	OVERR	FMERR	URBF	RXE
32	(Reserved)	-							
33	(Reserved)	-							
34	DCRB	R/W	R/W	R/W			R/W	R/W	R/W
		Bit7DC	Bit6DC	Bit5DC	-	-	Bit2DC	Bit1DC	Bit0DC
35	DCRC	R/W	R/W	R/W	R/W	R/W	R/W		
		Bit7DC	Bit6DC	Bit5DC	Bit4DC	Bit3DC	Bit2DC	-	-
36	DCRDE					R/W		R/W	
		-				DHNPU	-	DHND	-
37	DCRFG	R/W	R/W	R/W	R/W				
		GHNPU	GLNPU	GHND	GLND	-			
38	DCRHI					R/W	R/W	R/W	R/W
		-				HHNPU	HLNPU	HHND	HLND

Addr.	Register Name	Bit 7	Bit 6	Bit 5	Bit 4	Bit 3	Bit 2	Bit 1	Bit 0
39	(Reserved)	-							
3A	PBCON	R/W	R/W	R/W			R/W	R/W	R/W
		Bit7PU	Bit6PU	Bit5PU	-	-	Bit2PU	Bit1PU	Bit0PU
3B	PCCON	R/W	R/W	R/W	R/W	R/W	R/W		
		Bit7PU	Bit6PU	Bit5PU	Bit4PU	Bit3PU	Bit2PU	-	-
3C	PLLF	R Actual PLL Frequency Value Register							
3D	TOCL	R Timer 0 Counting Value Low Byte Register							
3E	TOCH	R Timer 0 Counting Value High Byte Register							
3F	SPICON	R/W	R/W	R/W	R/W	R/W	R/W	R/W	R/W
		TLS1	TLS0	BRS2	BRS1	BRS0	EDS	DORD	SE
40	SPISTA			R/W	R/W	R/W	R/W	R/W	R
		-	-	SRBFIE	SRBFI	SPWKEN	SMP	DCOL	RBF
41	SPRL	R/W Shift Register Low Byte of SPI							
42	SPRM	R/W Shift Register Middle Byte of SPI							
43	SPRH	R/W Shift Register High Byte of SPI							
44	SFCR	R/W	R/W	R/W	R/W	R/W	R/W	R/W	R/W
		AGMD2	AGMD1	AGMD0	WDTPRS1	WDTPRS0	SPHSB	CSB1	CSB0
45	ADDL	R/W Melody Channels 1~4 Address Low Byte Register							
46	ADDM	R/W Melody Channels1~4 address middle byte register.							
47	ADDH	R/W Melody Channels 1~4 Address High Byte Register							
48	ENV/SPHDR	R/W Melody Channels 1~4 Envelope Register/Speech Data Register							
49	MTCON/SPHTCON	R/W Melody Channels 1~4 Control Register/Speech Control Register							
4A	MTRL/SPHTRL	R/W Melody Channels 1~4 Reload Register/Speech Reload Register							
4B	VOCON	R/W		R/W	R/W	R/W	R/W	R/W	R/W
		VOEN	-	SETR1	SETR0	PWMP SR	VOL2	VOL1	VOL0
4C	TR1C	R Timer 1 Counting Value Register							
4D	TR2C	R Timer 2 Counting Value Register							

Addr.	Register Name	Bit 7	Bit 6	Bit 5	Bit 4	Bit 3	Bit 2	Bit 1	Bit 0
4E	ADCF	R/W A/D Clock Factor Register							
4F	(Reserved)	-							
50	LCDCONA	R/W BSEL2	R/W BSEL1	R/W BSEL0	R/W ADJ4	R/W ADJ3	R/W ADJ2	R/W ADJ1	R/W ADJ0
51	LCDCONB	R/W REV	-	R/W LCDON	R/W LCDPM2	R/W LCDPM1	R/W LCDPM0	R/W SFR1	R/W SFR0
52	LCDCONC	-	R/W DRSEL2	R/W DRSEL1	R/W DRSEL0	R/W BOOST	R/W LCDARH2	R/W LCDARH1	R/W LCDARH0
53	LCDARL	R/W LCD RAM Column Address							
54	LCDDATA	R/W Indirect Register to LCD RAM							
55	PACON					R/W Bit7PU	R/W /R2EN	R/W /R1EN	R/W KE

■ Other Un-banked Register of RAM:

Addr	Un-banked
56h   7Fh	General Purpose RAM

■ Banked Register of RAM:(selected by BSR)

Addr.	Bank 0	Bank 1	Bank 2	Bank 3	.....	Bank 15
80h   FFh	General Purpose RAM	General Purpose RAM	General Purpose RAM	General Purpose RAM	.....	General Purpose RAM

## 7.9 LCD RAM Map

LCD RAM	LCDARH [2:0]					
Address	101 (Page 05)	100 (Page 04)	011 (Page 03)	010 (Page 02)	001 (Page 01)	000 (Page 00)
LCDARL	COM47~COM40	COM39~COM32	COM31~COM24	COM23~COM16	COM15~COM8	COM7~COM0
	Bit 7 ~ Bit 0	Bit 7 ~ Bit 0	Bit 7 ~ Bit 0	Bit 7 ~ Bit 0	Bit 7 ~ Bit 0	Bit 7 ~ Bit 0
00H (SEG0)						
:						
3FH (SEG63)						
<b>40H ~ 4FH</b>	<b>Not for Use</b>					
50H (SEG80)						
:						
6FH (SEG111)						

**Note:** LCDARL = 40h ~ 4Fh is not for use



## 7.10 Special Register Description

### ■ STKPTR (R06h)

The stack level starts from the bottom going up (in a decreasing order), starting from 0FFh of BANK 15.

Stack is located at BANK 14 and 15 from address FFh~80h. Initial stack pointer is 00h.

Bits 0~6 of STKPTR are used as address pointer from 80h~FFh, Bit 7=1 is used to select BANK 15, Bit 7=0 is used to select BANK 14.

Each INT/CALL will stack two bytes address, total capacity is 128 levels.

### ■ PCL, PCM (R02h, R03h): Program Count Register

Bit 15	Bit 14	...	Bit 8	Bit 7	...	Bit 0
-	PCM			PCL		

Generates up to 32K×16 on-chip ROM addresses at the relative programming instruction codes.

“S0CALL” loads the low 12 bits of the PC (4K×16 ROM).

“SCALL” or “SJUMP” loads the low 13 bits of the PC (8K×16 ROM).

“LCALL” or “LJUMP” loads the full 15 bits of the PC (32K×16 ROM).

“ADD R2, A” or “ADC R2, A” allows a relative address to be added to the current PC. The carry bit of R2 will automatically carry into PCM.

#### Code Example:

```

START: MOV    A,entry
        MOV    number,a ;number <-- entry
        LCALL Indirect_JUMP
AAA:    .....
        .....

Indirect_JUMP:
        MOV    A,number
        ADD    A,ACC    ;A<-- 2*A
        ADD    PCL,A    ;PCL<-- PCL+A

function_table:
        LJMP  function_address_1 ; number=0
        LJMP  function_address_2 ; number=1
        LJMP  function_address_3 ; number=2
        LJMP  function_address_4 ; number=3
        LJMP  function_address_5 ; number=4
        LJMP  function_address_6 ; number=5
        LJMP  function_address_7 ; number=6
        .....
function_address_1:
        .....;Function 1 operation
        .....
        RET    ;PC will return to AAA label
    
```

- **ACC (R0Ah):** Accumulator. Internal data transfer, or instruction operand holding.

- **POST\_ID (R2Bh):** Post increase / decrease the control register

Bit 7	Bit 6	Bit 5	Bit 4	Bit 3	Bit 2	Bit 1	Bit 0
-	LCD_ID	FSR1_ID	FSR0_ID	-	LCDPE	FSR1PE	FSR0PE

**Bit 0 (FSR0PE):** Enable FSR0 post increase/decrease function, FSR0 will *NOT* carry into or borrow from BSR.

**Bit 1 (FSR1PE):** Enable FSR1 post increase/decrease function, FSR1 will carry into or borrow from BSR1.

**Bit 4 (FSR0\_ID):** Setting to 1 means auto increase, resetting to 0 means auto decrease of FSR0.

**Bit 5 (FSR1\_ID):** Setting to 1 means auto increase, resetting to 0 means auto decrease of FSR1.

◇ **Indirect Addressing Pointer 0**

- **BSR (R05h)** is determining which bank is active (working bank) among the 16 banks (Bank 0 ~ Bank 15).
- **FSR0 (R01h)** is an address register for INDF0. User can select up to 256 bytes (Address: 00 ~ 0FFh).
- **INDF0 (R00h)** is not a physically implemented register.

◇ **Indirect Addressing Pointer 1**

- **BSR1 (R07h)** is a bank register for INDF1. Cannot determine the working bank for the general register.
- **FSR1 (R09h)** is an address register for INDF1. User can select up to 128 bytes (Address: 80 ~ 0FFh); Bit 7 of FSR1 is fixed to 1.
- **INDF1 (R08h)** is not a physically implemented register.

**Code Example:**

```

Data transform Bank0 to Bank1:
MOV          A,#00110011B      ;Enable FSR0 & FSR1 post increase
MOV          POST_ID,A
BANK         #0                ;BSR = 0 working bank
MOV          A,#1
MOV          BSR1,A            ;BSR1 = 1 is Bank 1
MOV          A,#80H
MOV          FSR0,A            ;FSR0 = 80H
CLR          FSR1              ;FSR1 = 80H
MOV          A,#80H
RPT          ACC
MOVVRP      INDF1,INDF0       ;Move 80H ~ 0FFH data to Bank 1
:
```



Linear addressing capability of INDF1 is shown below:

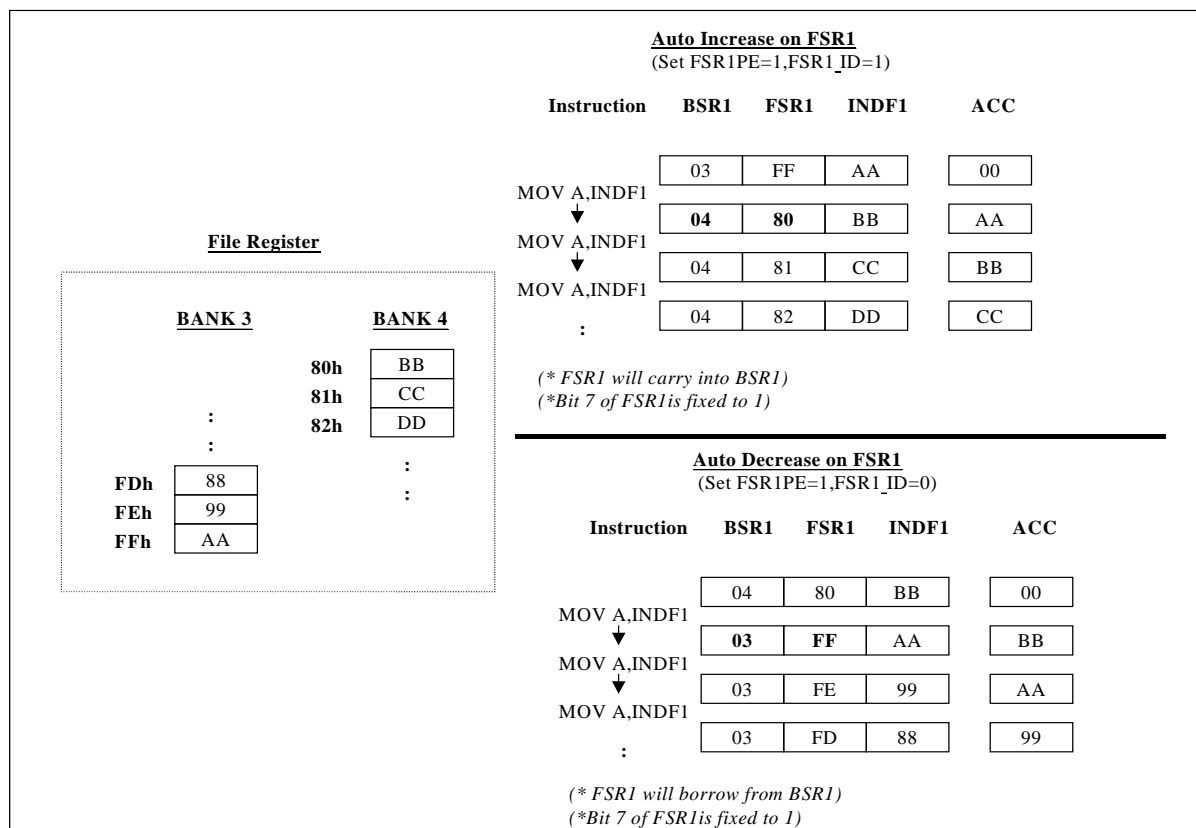

**Code Example:**

```

;*****
;*      Const => Working bank setting
;*      REG => Save or Recall register
;*****
; ***** RAM stack macro
; *** Initial RAM stack
IniRAMsk MACRO   #Const
    MOV    A,#Const
    MOV    BSR1,A
    CLR    FSR1
    BS     POST_ID,FSR1PE
ENDM

; *** Push RAM stack
PushRAM  MACRO   REG
    BS     POST_ID,FSR1_ID
    MOV    INDF1,REG
ENDM

; *** Pop RAM stack
PopRAM   MACRO   REG
    BC     POST_ID,FSR1_ID
    MOV    REG,INDF1
ENDM

; *** Main start program
Mstart:
    :
    :
    IniRAMsk    #29
    :
    :
MnLoop:
    :
    :
    LJMP      MnLoop

; *** Interrupt routine
IntSR:
    PushRAM   ACC
    PushRAM   Status
    :
    :
    PopRAM    Status
    PopRAM    ACC
    RETI
    
```

■ **TABPTRL, TABPTRM, TABPTRH (R0Bh, R0Ch, R0Dh): Table Pointer Register**

Bit 23	Bit 22	Bit 21	...	Bit 16	Bit 15	...	Bit 8	Bit 7	...	Bit 0
	-	-	TABPTRH		TABPTRM		TABPTRL			

■ Program ROM or Internal ROM address register:

**Bit 23** is used to select the internal/external memory.

**Bit 20 ~ Bit 1** are used to point the memory address.

**Bit 0** is used to select whether the pointed word is low or high byte (See TBRD instruction).

**Code Example:**

```

; *** Program ROM
:
:
TBPTH #(PROMTabB*2)/10000H
TBPTM #(PROMTabB*2)/100H
TBPTL # PROMTabB*2
:
:
TBRD 0,ACC ;no change
TBRD 1,ACC ;auto-increase
TBRD 2,ACC ;auto-decrease
:
:
; *** Program ROM data
PROMTabB:
DB 0x00,0x01,0x02,0x03,0x04,0x05
DB 0x10,0x11,0x12,0x13,0x14,0x15
DB 0x20,0x21,0x22,0x23,0x24,0x25

; *** Internal data ROM
INCLUDE "DROM_I.hdr";to ROMConverter
:
:
TBPTL #_Data_l
TBPTM #_Data_m
TBPTH #_Data_h
:
:
TBRD 0,ACC ;no change
TBRD 1,ACC ;auto-increase
TBRD 2,ACC ;auto-decrease
:
:

```

■ **PRODL, PRODH (R11h, R12h):** An unsigned or signed 8 × 8 hardware multiplier is included in the microcontroller. The result is stored into the 16 bits product register.

■ **CPUCON (R0Eh): MCU Control Register**

Bit 7	Bit 6	Bit 5	Bit 4	Bit 3	Bit 2	Bit 1	Bit 0
PEN	-	-	SMCAND	SMIER	GLINT	MS1	MS0

**Bit 3 (SMIER):** Signed or unsigned selection bit of the Multiplier. (ACC)

“0” : The Multiplier is unsigned

“1” : The Multiplier is signed

**Bit 4 (SMCAND):** Signed or unsigned selection bit of the Multiplicand.

(Constant or Register)

“0” : The Multiplier is unsigned

“1” : The Multiplier is signed

**Code Example:**

```

; *** Signed multiplier operation
; === PRODH:PRODL = A x REG
BS CPUCON,SMIER
BS CPUCON,SMCAND
MUL A,REG

; *** Unsigned multiplier operation
; === PRODH:PRODL = A x #k
BC CPUCON,SMIER
BC CPUCON,SMCAND
MUL A,# 88

```



- **Port A (R17h)** is a general input register

- **STBCON (R21h):** Strobe Output Control Register

Bit 7	Bit 6	Bit 5	Bit 4	Bit 3	Bit 2	Bit 1	Bit 0
UINVEN	SCAN	BitST	ALL	STB3	STB2	STB1	STB0

**Bit 5 (BitST):** Enable SEG0 ~ SEG15 as key strobe pins.

“0” : SEG0 ~ SEG15 are used as LCD segment signal pins only.

“1” : SEG0 ~ SEG15 are used as key strobe pins and LCD segment pins. Strobe signal defined as **STB3~0**.

- **PACON (R55h):** Port A Control Register

Bit 7	Bit 6	Bit 5	Bit 4	Bit 3	Bit 2	Bit 1	Bit 0
-	-	-	-	Bit7PU	/R2EN	/R1EN	KE

**Bit 0 (KE):** Key input enable/disable control bit.

“0” : Disable Key input function (Port A register does NOT correspond with Key input in software scan mode).

“1” : Enable Key input function (Port A register corresponds with Key input in software scan mode).

**Bit 1 (/R1EN):** R1 pull-up resistor (small resistor) control bit.

“0” : Enable R1 pull-up resistor

“1” : Disable R1 pull-up resistor

**Bit 2 (/R2EN):** R2 pull-up resistor (large resistor) control bit.

“0” : Enable R2 pull up resistor

“1” : Disable R2 pull up resistor

**Bit 3 (Bit 7PU):** Enable Port A.7 pull-up resistor.

“0” : Disable pull-up resistor

“1” : Enable pull up resistor

- **PAINTEN (R2Dh)** is Port A interrupt control register

“0” : Disable interrupt function

“1” : Enable interrupt function

- **PAINTSTA (R2Eh)** is Port A interrupt status register

Set to “1” when pin falling edge is detected

Clear to “0” by software

- **PAWAKE (R2Fh)** is Port A wake-up control register

“0” : Disable wake-up function

“1” : Enable wake-up function

- **Port B.7 ~ 5, Port B.2 ~ 0 (R18h)** are general I/O registers

■ **DCRB (R34h):** Direction Control of Port B

**Bit 7 ~ Bit 5, Bit 2 ~ Bit 0 (Bit 7DC ~ Bit 5DC, Bit 2DC ~ Bit 0DC):**

“0” : Output pin setting

“1” : Input pin setting

■ **PBCON (R3Ah):** Pull-up Resistor Control of Port B

**Bit 7 ~ Bit 5, Bit 2 ~ Bit 0 (Bit 7PU ~ Bit 5PU, Bit 2PU ~ Bit 0PU):**

“0” : Disable pull-up resistor

“1” : Enable pull-up resistor

■ **Port C.7~2 (R19h)** are General I/O Registers

■ **DCRC (R35h):** Direction Control of Port C

**Bit 7 ~ Bit 2 (Bit 7DC ~ Bit 2DC):**

“0” : Output pin setting

“1” : Input pin setting

■ **PCCON (R3Bh):** Pull-up Resistor Control of Port C

**Bit 7 ~ Bit 2 (Bit 7PU ~ Bit 2PU):**

“0” : Disable pull-up resistor

“1” : Enable pull-up resistor

■ **Port D (R1Ah)** is a General I/O Register

■ **DCRDE (R36h):** Direction Control & Pull-up Resistor Control of Port D

Bit 7	Bit 6	Bit 5	Bit 4	Bit 3	Bit 2	Bit 1	Bit 0
-	-	-	-	DHNPU	DLNPU	DHNDC	DLNDC

**Bit 1 (DHNDC) & Bit 0 (DLNDC):** Port D high / low nibbles direction control

“0” : Output pin setting

“1” : Input pin setting

**Bit 3 (DHNPU) & Bit 2 (DLNPU):** Enable Port D high / low nibble pull-up resistor

“0” : Disable pull up resistor

“1” : Enable pull-up resistor

■ **Port G (R1Dh)** : General I/O Register

■ **DCRFG (R37h):** Direction Control & Pull-up Resistor Control of Port G

Bit 7	Bit 6	Bit 5	Bit 4	Bit 3	Bit 2	Bit 1	Bit 0
GHNPU	GLNPU	GHNDC	GLNDC	-	-	-	-

**Bit 5 (GHNDC) & Bit 4 (GLNDC):** Port G high / low nibble direction control

“0” : Output pin setting

“1” : Input pin setting

**Bit 7 (GHNPU) & Bit6 (GLNPU):** Enable Port G high / low nibble pull-up resistor

“0” : Disable pull-up resistor

“1” : Enable pull-up resistor



■ Port H (R1Eh) is a General I/O Register

■ DCRHI (R38h): Direction Control & Pull-up Resistor Control of Port H

Bit 7	Bit 6	Bit 5	Bit 4	Bit 3	Bit 2	Bit 1	Bit 0
-	-	-	-	HHNPU	HLNPU	HHNDC	HLNDC

**Bit 1 (HHNDC) & Bit 0 (HLNDC):** Port H high / low nibbles direction control.

“0” : Output pin setting

“1” : Input pin setting

**Bit 3 (HHNPU) & Bit 2 (HLNPU):** Enable Port H high / low nibbles pull up resistor.

“0” : Disable pull-up resistor

“1” : Enable pull-up resistor

**Code Example:**

```

; *** Port A function
; --- Port A interrupt
INPTINT:
    PUSH
    MOV     A, PAINTSTA
    BC     STBCON, BitST
; --- Port A interrupt
    JBS     STATUS, F_Z, Q_PAINT
    MOV     PORTH, A
Q_PAINT:
    POP
    RETI
; --- Port H output
    CLR     DCRHI
; --- Port A pull-up enable
    MOV     A, #00001001B
    MOV     PACON, A
; --- Port A interrupt
    MOV     A, #11111111B
    MOV     PAINTEN, A
    CLR     PAINTSTA
; --- Port A wakeup
    MOV     PAWAKE, A
    BS     CPUCON, GLINT
; --- Sleep mode
    BC     CPUCON, MS1
KeyLoop:
    BS     STBCON, BitST
    SLEP
    NOP
    :
    SJMP   KeyLoop
; *** Output function => 0XAAh to all port
    CLR     DCRC
    CLR     DCRB
    CLR     DCRDE
    CLR     DCRFG
    CLR     DCRHI
    MOV     A, #0XAA
    MOV     PORTC, A
    MOV     PORTB, A
    MOV     PORTD, A
    MOV     PORTG, A
    MOV     PORTH, A
; *** Input function => Input port to RAM 80 ~ 83h
    BS     POST_ID, FSR1_ID
    BS     POST_ID, FSR1PE
    CLR     BSR1
    CLR     FSR1
    MOV     A, #00001001B
    MOV     PACON, A
    MOV     A, #0XFF
    MOV     DCRB, A
    MOV     PBCON, A
    MOV     DCRC, A
    MOV     PCCON, A
    MOV     DCRDE, A
    BS     STBCON, BitST
    MOV     INDF1, PORTA
    BC     STBCON, BitST
    MOV     INDF1, PORTB
    MOV     INDF1, PORTC
    MOV     INDF1, PORTD
    
```

**NOTE**

*When Port G and Port H are set input pins, a 5 μsec delay in reading their data must be provided. Otherwise, read data will be inaccurate. See example below.*

**Code Example:**

```

; *** Set Port G & Port H input pins and Pull-high
    MOV     A, #0XFF
    MOV     DCRFG, A
    MOV     DCRHI, A
; Read_PG:
    JBS     PORT G, 0, Read_PG
    Delay   5μsec
    JBS     PORT G, 0, Read_PG
    :
    
```

## 8 Peripheral

### 8.1 Timer 0 (16-bit Timer with Capture and Event Counter Functions)

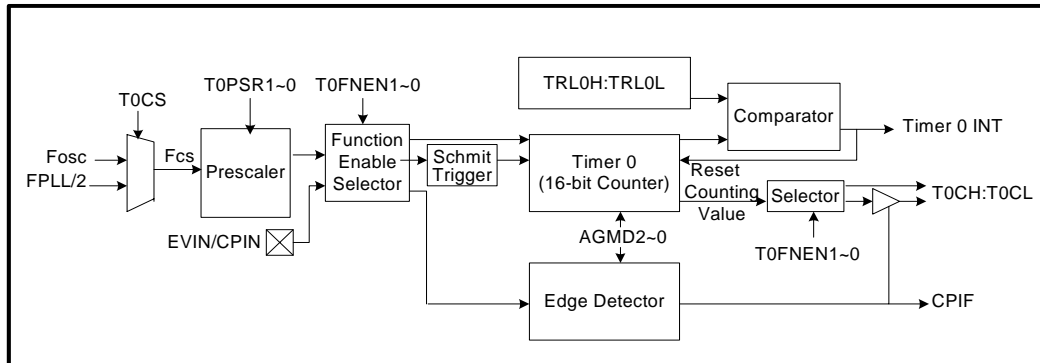

Fig. 8-1 Timer 0 Function Block Diagram

#### ◇ Timer 0 Mode:

In this mode, Timer 0 is used as a general-purpose 16-bit up counter. There is an interrupt available for user's application.

There is a prescaler for the timer. The T0PSR2~T0PSR0 bits of the TR01CON register determine the prescaler ratio and generate different clock rates for the timer clock source. Counter value will be incremented by one (counting up) according to the timer clock source and stored into the T0CH: T0CL register. The clock source (Fcs) is selected from Fosc or  $F_{PLL}/2$  by T0CS and pre-scaled by T0PSR1~0. When the counting value is larger than TRLOH: TRLOL value, Timer 0 interrupt will occur, and the counter value will be reset to zero automatically.

$$T = \frac{1}{Fcs} \times Prescaler \times (TRLOH : TRLOL + 1)$$

The Timer 0 frequency range is from 1/128 Hz (clock source is from Fosc, TRLOH: TRLOL = 0FFFFh, pre-scale = 1: 64) to 5MHz (clock source is from  $F_{PLL}/2$ , system clock is 10MHz, TRLOH: TRLOL = 0000h, pre-scale = 1:1).

#### ◇ Capture Mode: CPIN (Port B.5) Pin

Capture is a function that captures the Timer 0 value when an event occurs on CPIN pin.

The counter value is captured at: 1st rising edge, 2nd falling edge, etc.; 1st falling edge, 2nd rising edge, etc.; every rising edge or every falling edge selected by AGMD2~0 bit of the SFCR register. When an event edge is detected from CPIN input pin, the interrupt flag CPIF is set. If a new event edge is detected before the old value in T0CH: T0CL register is read, the old captured value will be lost.

The CPIN pin should be configured in capture function input by setting T0FNEN1~0 bits of TR2CON register.

$$T = \frac{1}{F_{cs}} \times Pr_{escaler} \times [(T0CH : T0CL)_{NEW} - (T0CH : T0CL)_{OLD}]$$

#### Capture Mode Example:

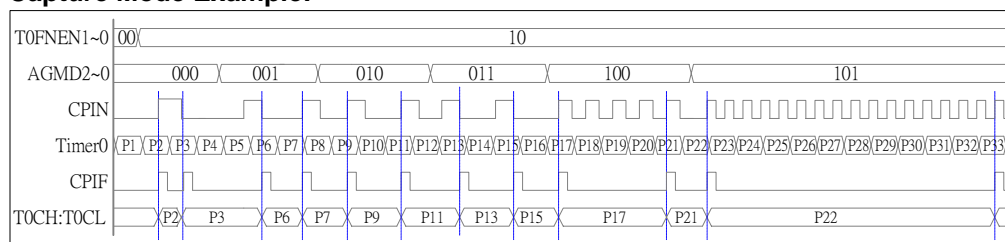

#### ✧ Event Counter Mode: EVIN (Port B.5) Pin

Event counter is a function wherein the 16-bit counter value increments by one when an event occurs on EVIN pin at: every rising edge or every falling edge selected by AGMD2~0 bit of the SFCR register. In other words, the Timer 0 clock source is from an external event (EVIN pin).

The EVIN pin should be configured in event counting function input by setting the T0FNEN1~0 bits of the TR2CON register. The counting value of Timer 0 will be stored in T0CH: T0CL registers.

#### Event Counter Mode Example:

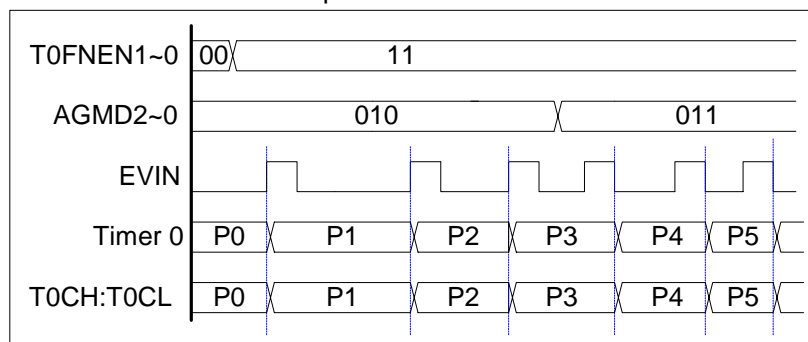

- **TRL0H, TRL0L (R25h, R24h):** Used to store the value comparing with Timer 0 register.
- **T0CH, T0CL (R3Eh, R3Dh):** Used to store the Timer 0 counting value in Timer 0 mode and Event counter mode. But in Capture mode, it is used to store the captured value.

■ **TR01CON (R27h):** Timer 0 and Timer 1 Control Register

Bit 7	Bit 6	Bit 5	Bit 4	Bit 3	Bit 2	Bit 1	Bit 0
T1WKEN	T1EN	T1PSR1	T1PSR0	IREN	T0CS	T0PSR1	T0PSR0

**Bit 1 ~ Bit 0 (T0PSR1~T0PSR0):** Timer 0 Prescaler select bit

T0PSR1: T0PSR0	Prescaler Value
00	1:1
01	1:4
10	1:16
11	1:64

**Bit 2 (T0CS):** Timer 0 clock source select bit

“0” : Clock source is from Fosc

“1” : Clock source is from FPLL/2

■ **TR2CON (R28h):** Timer 2 Control Register

Bit 7	Bit 6	Bit 5	Bit 4	Bit 3	Bit 2	Bit 1	Bit 0
IRPSR1	IRPSR0	T0FNEN1	T0FNEN0	T2EN	T2CS	T2PSR1	T2PSR0

**Bit 5 ~ Bit 4 (T0FNEN1 ~ T0FNEN0):** Timer 0 and Capture, event counter mode selection bits.

■ **SFCR (R44h):** Special Function Control Register

Bit 7	Bit 6	Bit 5	Bit 4	Bit 3	Bit 2	Bit 1	Bit 0
AGMD2	AGMD1	AGMD0	WDTPSR1	WDTPSR0	SPHSB	CSB1	CSB0

**Bit 7 ~ Bit 5 (AGMD2 ~ AGMD0):** Capture and Event Counter function edge detector selection bits.

T0FNEN 1 ~ 0	Mode	AGMD 2~0	Edge Mode
00	Disable	-	-
01	Timer 0	-	-
10	Capture	000	1st Rising edge, 2nd falling edge, etc.
		001	1st Falling edge, 2nd rising edge, etc.
		010	Every rising edge
		011	Every falling edge
		100	Every 4th rising edge
		101	Every 16th rising edge
11	Event Counter	010	Every rising edge
		011	Every falling edge

**Note:** 1. In changing from one mode to another, it is necessary to disable the Timer 0.  
2. To avoid error, simultaneously setup T0FNEN1 and T0FNEN0.

■ **CPUCON (R0Eh):** MCU Control Register

Bit 7	Bit 6	Bit 5	Bit 4	Bit 3	Bit 2	Bit 1	Bit 0
PEN	-	-	SMCAND	SMIER	GLINT	MS1	MS0

**Bit 2 (GLINT):** Global Interrupt Control Bit

“0” : Disable all interrupts

“1” : Enable all un-masked interrupt

■ **INTCON (R22h):** Interrupt Control Register

Bit 7	Bit 6	Bit 5	Bit 4	Bit 3	Bit 2	Bit 1	Bit 0
CPIE	ADIE	URXIE	UTXIE	UERRIE	TMR2IE	TMR1IE	TMR0IE

**Bit 0 (TMR0IE):** Timer 0 Interrupt Control Bit

“0” : Disable Timer 0 interrupt

“1” : Enable Timer 0 interrupt

**Bit 7 (CPIE):** Capture Interrupt Control bit

“0” : Disable Capture interrupt

“1” : Enable Capture interrupt

■ **INTSTA (R23h):** Interrupt Status Register

Bit 7	Bit 6	Bit 5	Bit 4	Bit 3	Bit 2	Bit 1	Bit 0
CPIF	ADIF	URXI	UTXI	UERRI	TMR2I	TMR1I	TMR0I

**Bit 0 (TMR0I):** Set to 1 when Timer 0 is larger than TRL0H ~ TRL0L value

Clear to 0 by software or Timer 0

**Bit 7 (CPIF):** Set to 1 when Capture input edge is detected

Clear to 0 by software or disable Capture

**Code Example:**

```

;===Timer 0 interrupt
TIMERINT:
    PUSH
    JBC    INTSTA,TMR0I,Q_Time
    BC    INTSTA,TMR0I
    BTG   PORTC,3
Q_Time:
    POP
    RETI
;===Timer 0 = (8M/2) / [4 x 3FFF + 1]
Timer0SR:
    :
    System setting 8MHz
    PC.2 Port H & G setting output port
    :
; --- Fp11 & Prescale 1:4

;===Capture Input Interrupt
CAPINT:
    PUSH
    JBS   INTSTA,CPIF,Q_ICAP
    BC   INTSTA,CPIF
    BTG  PORTC,3
    BS   INTFLAG,F_ICAP
Q_ICAP:
    POP
    RETI
;
;===1st falling edge,2nd rising edge, etc.
CAP_SR:
    System setting 8MHz
    PC.2 Port H & G setting output port
    User setting F_ICAP flag
    
```



```
MOV    A,#00000101B
MOV    TR01CON,A
; --- 4ms = (4 x 16383 + 1)/(8M/2)
MOV    A,#0FFH
MOV    TRL0L,A
MOV    A,#03FH
MOV    TRL0H,A
; --- Timer 0 mode
MOV    A,#00010000B
MOV    TR2CON,A
; --- Timer 0 interrupt enable
BS     INTCON,TMR0IE
; --- Clear Timer 0 interrupt status.
BC     INTSTA,TMR0I
; --- Enable global interrupt
BS     CPUCON,GLINT
TimeLoop:
; --- Out Timer 0 count to Port H:G
MOV    PORTH,T0CH
MOV    PORTG,T0CL
SJMP  TimeLoop

; --- Count end => 0FFFFH
MOV    A,#0XFF
MOV    TRL0H,A
MOV    TRL0L,A
; --- PLL/2 & Prescaler 1:1
; --- (8MHz/2)/65536=61Hz
MOV    A,#00000100B
MOV    TR01CON,A
; --- 1st Falling - 2nd Rising
MOV    A,#00100000B
MOV    SFCR,A
BS     INTCON,CPIE
; --- 10->Capture Enable
MOV    A,#00100000B
MOV    TR2CON,A
BC     INTFLAG,F_ICAP
BS     CPUCON,GLINT
CAP_LOOP:
JBC   INTFLAG,F_ICAP,CAP_LOOP
BC    INTFLAG,F_ICAP
; --- Out capture count to Port H:G
MOV    PORTH,T0CH
MOV    PORTG,T0CL
SJMP  CAP_LOOP

; === Every rising edge
EVcntSR:
:
System setting 8MHz
Port H & G setting output port
:
MOV    A,#0XFF           ; Switch 256 times reload
MOV    TRL0L,A
CLR    TRL0H             ; Count start 0000H
BS     TR01CON,T0CS      ; PLL/2
MOV    A,#01000000B
MOV    SFCR,A           ; Rising edge
MOV    A,#00110000B
MOV    TR2CON,A         ; 11->Event count Enable
EV_LOOP:
MOV    PORTH,T0CH       ; Out event count to Port H:G
MOV    PORTG,T0CL
SJMP  EV_LOOP
```

## 8.2 Timer 1 (8 Bits)

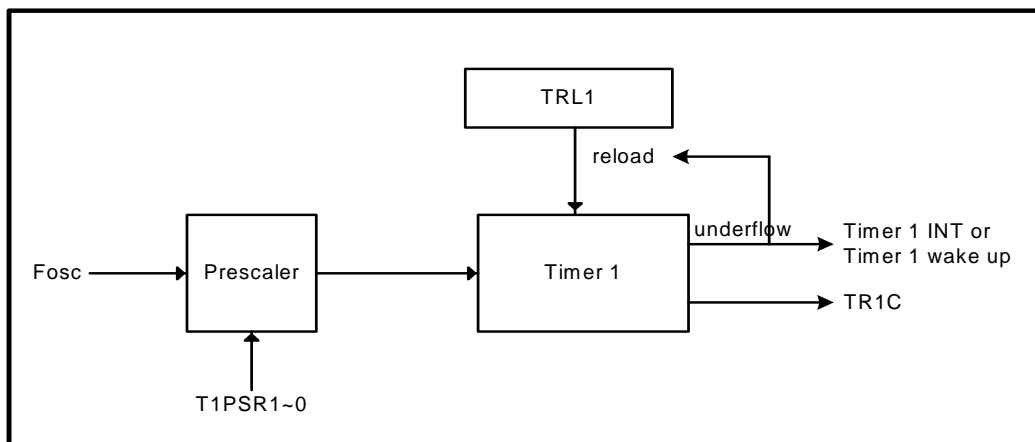

Fig. 8-2 Timer 1 Function Block Diagram

Timer 1 is a general-purpose 8-bit down counter for some applications requiring time counting. There are interrupt and wake up function available for user's application. The clock source is from the oscillator clock.

There is a prescaler for the timer. The **T1PSR1~T1PSR0** bits of the TR01CON register determine the prescaler ratio and generate different clock rates for the timer clock source. Setting **T1WKEN** bit of the TR01CON register to 1 will enable the Timer 1 underflow wake-up function in IDLE MODE.

Counting value will be decremented by one (count down) according to the real timer clock source. When the counter underflows, the timer interrupt will be triggered if the global interrupt and Timer 1 interrupt are both enabled. At the same time, the TRL1 value will automatically be reloaded into the 8 bits counter.

$$T = \frac{1}{F_{osc}} \times Prescaler \times (TRL1 + 1)$$

The Timer 1 frequency range is from 0.5Hz (TRL1 = 0FFh, prescaler = 1:256) to 8.192kHz (TRL1 = 0h, prescaler = 1:4). The clock source is from the oscillator clock (Fosc).

- **TRL1 (R26h):** Used to store the auto-reload value of Timer 1. When enabling Timer 1 or an underflow occurs, TRL1 register value will automatically be reloaded into the 8 bits counter.
- **TR1C (R4Ch):** Used to store the Timer 1 Counting Value

■ **TR01CON (R27h):** Timer 0 and Timer 1 Control Register

Bit 7	Bit 6	Bit 5	Bit 4	Bit 3	Bit 2	Bit 1	Bit 0
T1WKEN	T1EN	T1PSR1	T1PSR0	IREN	T0CS	T0PSR1	T0PSR0

**Bit 5 ~ Bit 4 (T1PSR1~T1PSR0):** Timer 1 Pre-scale Select Bit.

T1PSR1: T1PSR0	Prescaler Value
00	1:4
01	1:16
10	1:64
11	1:256

**Bit 6 (T1EN):** Timer 1 Enable Control Bit

“0” : Disable Timer 1 (stop counting)

“1” : Enable Timer 1

**Bit 7 (T1WKEN):** Enable bit of Timer 1 underflow wake-up function in IDLE MODE.

“0” : Disable Timer 1 wake-up function

“1” : Enable Timer 1 wake-up function

■ **CPUCON (R0Eh):** MCU Control Register

Bit 7	Bit 6	Bit 5	Bit 4	Bit 3	Bit 2	Bit 1	Bit 0
PEN	-	-	SMCAND	SMIER	GLINT	MS1	MS0

**Bit 2 (GLINT):** Global Interrupt Control Bit

■ **INTCON (R22h):** Interrupt Control Register

Bit 7	Bit 6	Bit 5	Bit 4	Bit 3	Bit 2	Bit 1	Bit 0
CPIE	ADIE	URXIE	UTXIE	UERRIE	TMR2IE	TMR1IE	TMR0IE

**Bit 1 (TMR1IE):** Control Bit of Timer 1 Interrupt

“0” : Disable Timer 1 interrupt

“1” : Enable Timer 1 interrupt

■ **INTSTA (R23h):** Interrupt Status Register

Bit 7	Bit 6	Bit 5	Bit 4	Bit 3	Bit 2	Bit 1	Bit 0
CPIF	ADIF	URXI	UTXI	UERRI	TMR2I	TMR1I	TMR0I

**Bit 1 (TMR1I):** Set to 1 when Timer 1 interrupt occurs

Clear to 0 by software or disable Timer 1

**Code Example:**

```
; === Timer 1 interrupt
TIMERINT:
    PUSH
    JBC    INTSTA,TMR1I,Q_Time
    BC     INTSTA,TMR1I
    BTG    PORTC,3
Q_Time:
    POP
    RETI
; === Timer 1 = 32.768K/[256 x 3F + 1]
Timer1SR:
    :
    PC.2 setting output port
    :
    MOV    A,#10110000B
    MOV    TR01CON,A           ; Fosc & Prescale 1:256 & wakeup
    MOV    A,#03FH
    MOV    TRL1,A             ; 0.5sec = (256 x 63 + 1)/32.768K
    BS     TR01CON,T1EN       ; Timer 1 enable
    BS     INTCON,TMR1IE     ; Timer 1 interrupt enable
    BC     INTSTA,TMR1I     ; Clear Timer 1 interrupt status
    BS     CPUCON,GLINT      ; Enable global interrupt
    BS     CPUCON,MS1        ; Idle mode
T1WLoop:
    SLEP
    NOP
    :
    SJMP  T1Wloop
```

### 8.3 Timer 2 (8 Bits)

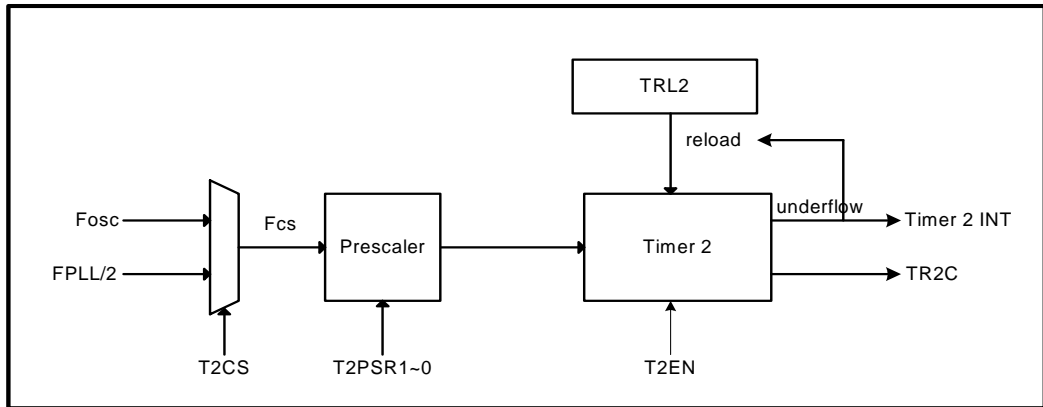

Fig. 8-3 Timer 2 Function Block Diagram

Timer 2 is a general-purpose 8-bit down counter for some applications requiring time counting. There are interrupt functions available for user's application. The clock source (Fcs) is from the oscillator clock or FPLL/2.

There is a prescaler for the timer. The T2PSR1~T2PSR0 bits of the TR2CON register determine the prescaler ratio and generate different clock rates for the timer clock source.

Counting value will be decremented by one (counting down) according to the timer clock source. When the counter value underflows, a timer interrupt will occur (if Timer 2 interrupt is enabled).

$$T = \frac{1}{F_{cs}} \times \text{Pr escaler} \times (TRL2 + 1)$$

The Timer 2 frequency range is from 16Hz (clock source is from Fosc, TRL2 = 0FFh, prescaler = 1:8) to 5MHz (clock source is from FPLL/2, system clock is 10MHz, TRL2 = 00h, prescaler = 1:1)

- **TRL2 (R10h):** Used to store the auto-reload value of Timer 2. When enabling Timer 2 or an underflow occurs, TRL2 register will automatically be reloaded into the 8 bits counter.
- **TR2C (R4Dh):** Used to store the Timer 2 counting value

■ **TR2CON (R28h):** Timer 2 Control Register

Bit 7	Bit 6	Bit 5	Bit 4	Bit 3	Bit 2	Bit 1	Bit 0
IRPSR1	IRPSR0	T0FNEN1	T0FNEN0	T2EN	T2CS	T2PSR1	T2PSR0

**Bit 1 ~ Bit 0 (T2PSR1~T2PSR0):** Timer 2 Pre-scale select bit.

T2PSR1: T2PSR0	Pre-scale value
00	1:1
01	1:2
10	1:4
11	1:8

**Bit 2 (T2CS):** Timer 2 Clock Source Select Bit

“0” : Clock source is from Fosc

“1” : Clock source is from FPLL/2

**Bit 3 (T2EN):** Timer 2 Enable Control Bit

“0” : Disable Timer 2 (stop counting)

“1” : Enable Timer 2

■ **CPUCON (R0Eh):** MCU Control Register

Bit 7	Bit 6	Bit 5	Bit 4	Bit 3	Bit 2	Bit 1	Bit 0
PEN	-	-	SMCAND	SMIER	GLINT	MS1	MS0

**Bit 2 (GLINT):** Global Interrupt Control Bit

■ **INTCON (R22h):** Interrupt Control Register

Bit 7	Bit 6	Bit 5	Bit 4	Bit 3	Bit 2	Bit 1	Bit 0
CP1E	AD1E	URX1E	UTX1E	UERR1E	TMR21E	TMR11E	TMR01E

**Bit 2 (TMR21E):** Timer 2 Interrupt Control Bit

“0” : Disable Timer 2 interrupt

“1” : Enable Timer 2 interrupt

■ **INTSTA (R23h):** Interrupt Status Register

Bit 7	Bit 6	Bit 5	Bit 4	Bit 3	Bit 2	Bit 1	Bit 0
CP1F	AD1F	URX1I	UTX1I	UERR1I	TMR21I	TMR11I	TMR01I

**Bit 2 (TMR21I):** Set to 1 when Timer 2 interrupt occurs

Clear to 0 by software or disable Timer 2

**Code Example:**

```

; === Timer 2 interrupt
TIMERINT:
    PUSH
    JBC  INTSTA,TMR2I,Q_Time
    BC   INTSTA,TMR2I
    BTG  PORTC,3
Q_Time:
    POP
    RETI
; === Timer 2 = (8M/2)/[4 x 3F + 1]
Timer2SR:
    :
    System setting 8MHz
    Port G setting output port
    :
    MOV  A,#00000110B
    MOV  TR2CON,A           ; Fpll & Prescaler 1:4
    MOV  A,#03FH
    MOV  TRL2,A           ; 16us = (4 x 63 + 1)/(8M/2)
    BS   TR2CON,T2EN      ; Timer 2 enable
    BS   INTCON,TMR2IE   ; Timer 2 interrupt enable
    BC   INTSTA,TMR2I    ; Clear Timer 2 interrupt status
    BS   CPUCON,GLINT    ; Enable global interrupt
TMR2Loop:
    MOV  RPL PORTH,TR2C   ; Out Timer 2 count to Port H
    SJMP TMR2Loop

```

## 8.4 IR Generator: IROT (Port B.2) Pin

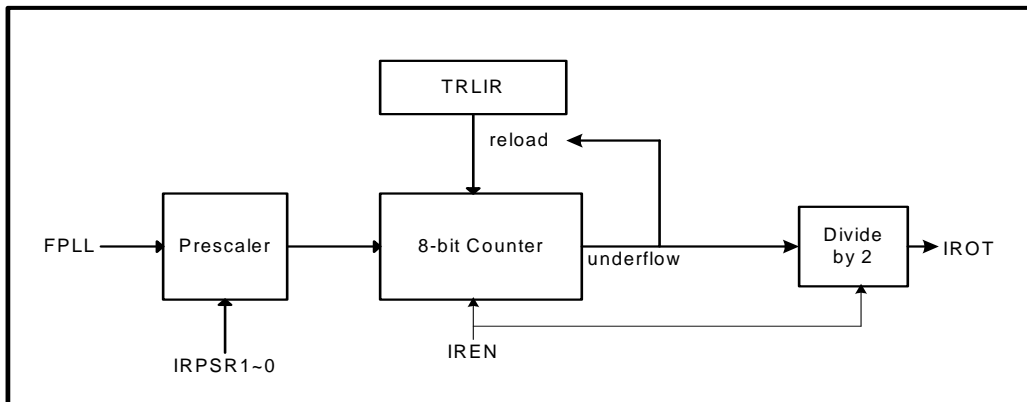

Fig. 8-4 IR Generator Function Block Diagram

IR function is enabled by IREN bit and output on the IROT (Port B.2) pin by a general-purpose 8-bit down counter. When IREN is low, the T-flip-flop should be initialized, as IROT equals zero. The clock source is from PLL clock. The IRPSR1 ~ IRPSR0 bits of the TR2CON register determine the prescaler ratio and generate different clock rates for the timer clock source. The counting value will be decremented by one (counting down) according to the clock source. When the counter value underflows, the IR reload register value will be reloaded into the counter.

$$T = \frac{2}{F_{PLL}} \times \text{Prescaler} \times (TRLIR + 1)$$

The maximum frequency of the IROT carrier signal will be 5MHz (FPLL clock at 10MHz, TRLIR = 0h).

- **TRLIR (R29h):** Used to store the auto-reload value of the IR generator. When enabling the IR generator or when an underflow occurs, the TRLIR register value will automatically be reloaded into the 8 bits counter.
- **TR01CON (R27h):** Timer 0 and Timer 1 Control Register

Bit 7	Bit 6	Bit 5	Bit 4	Bit 3	Bit 2	Bit 1	Bit 0
T1WKEN	T1EN	T1PSR1	T1PSR0	IREN	T0CS	T0PSR1	T0PSR0

**Bit 3 (IREN):** IR function enable control bit

“0” : Disable IR function and recover IROT pin as a general I/O pin.

“1” : Enable IR function and change Port B.2 as IROT output pin.

■ **TR2CON (R28h):** Timer 2 Control Register

Bit 7	Bit 6	Bit 5	Bit 4	Bit 3	Bit 2	Bit 1	Bit 0
IRPSR1	IRPSR0	TOFNEN1	TOFNEN0	T2EN	T2CS	T2PSR1	T2PSR0

**Bit 7 ~ Bit 6 (IRPSR1~IRPSR0):** IR Generator Prescaler Select Bit

IRPSR1: IRPSR0	Prescaler Value
00	1:1
01	1:4
10	1:16
11	1:64

**Code Example:**

```

; === IR generator 31kHz
;
; System setting 10MHz
;
MOV    A, #10000000B
MOV    TR2CON, A    ; Prescaler 1: 16
MOV    A, #9
MOV    TRLIR, A     ; 10MHz / [ 2 x 16 x ( 9 + 1 ) ] = 31kHz
BS     TR01CON, IREN
IR_Loop:
    SJMP IR_Loop

```

## 8.5 Watchdog Timer (WDT)

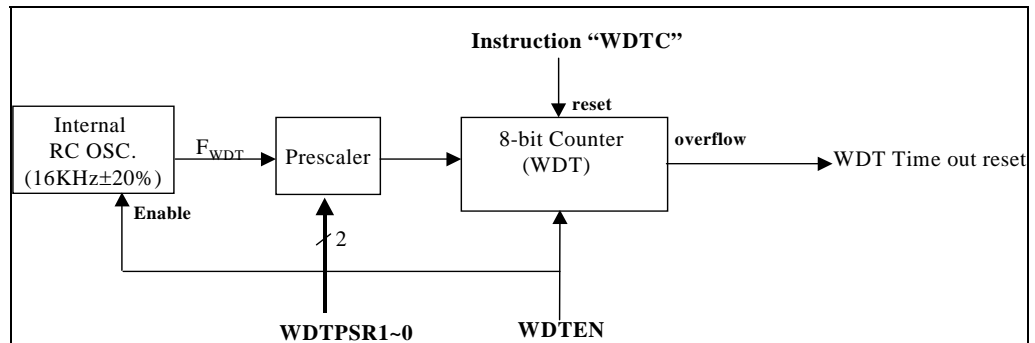

Fig. 8-5 Watchdog Timer Function Block Diagram

The watchdog timer (WDT) clock source is from the on-chip RC oscillator (16kHz ± 20%). The WDT will keep running even when the oscillator has been turned off (i.e. in SLEEP MODE). WDT time-out will cause the MCU to reset (if WDT is enabled). To avoid a reset to occur, user should clear the WDT value by using the “WDTC” instruction before WDT time-out. Setting the WDTEN bit will enable the WDT function. Disable is the WDT default condition. There is also a prescaler to generate different clock rates for the WDT clock source. The prescaler ratio is defined by WDTPSR1 ~ WDTPSR0.

$$T = \frac{1}{F_{WDT}} \times \text{Prescaler} \times (WDT + 1)$$

The WDT time out range is 64ms (prescaler = 1:4) to 2.048 second (prescaler = 1:128).



■ **ADOTL (R13h):** A/D Output Data Low Byte Register

Bit 7	Bit 6	Bit 5	Bit 4	Bit 3	Bit 2	Bit 1	Bit 0
WDTEN	-	ADWKEN	-	-	FSS	ADOT1	ADOT0

**Bit 7 (WDTEN):** Watchdog Timer enable bit.  
 "0" : Disable Watchdog Timer (stop running)  
 "1" : Enable Watchdog Timer

■ **SFCR (R44h):** Special Function Control Register

Bit 7	Bit 6	Bit 5	Bit 4	Bit 3	Bit 2	Bit 1	Bit 0
AGMD2	AGMD1	AGMD0	WDTPSR1	WDTPSR0	SPHSB	CSB1	CSB0

**Bit 4 ~ Bit 3 (WDTPSR1~WDTPSR0):**

Watchdog Timer Pre-scale select bit

WDTPSR1: WDTPSR0	Prescaler Value
00	1:4
01	1:16
10	1:64
11	1:128

**Code Example:**

```

; === WDT setting 2.048sec
:
Timer 1 (0.5sec wakeup)
:
BS   SFCR,WDTPSR0
BS   SFCR,WDTPSR1 ; Prescaler 1:128
BC   CPUCON,MS1   ; Change to sleep mode
WDTC
SLEP
WDT_Loop:
    SJMP WDT_Loop

; === Timer 1 interrupt 0.5 sec
TIMERINT:
    PUSH
    JBC   INTSTA,TMR1I,Q_Time
    BC   INTSTA,TMR1I
    WDTC
    :
    :
Q_Time:
    POP
    RETI
    
```

## 8.6 Universal Asynchronous Receiver Transmitter (UART)

- RS232C compatible
- Mode selectable (7/8/9-bit) with/without parity bit
- Baud rate selectable
- Error detect function
- Interrupt available for Tx buffer empty, Rx buffer full and receiver error
- TXD and RXD port inverse output control

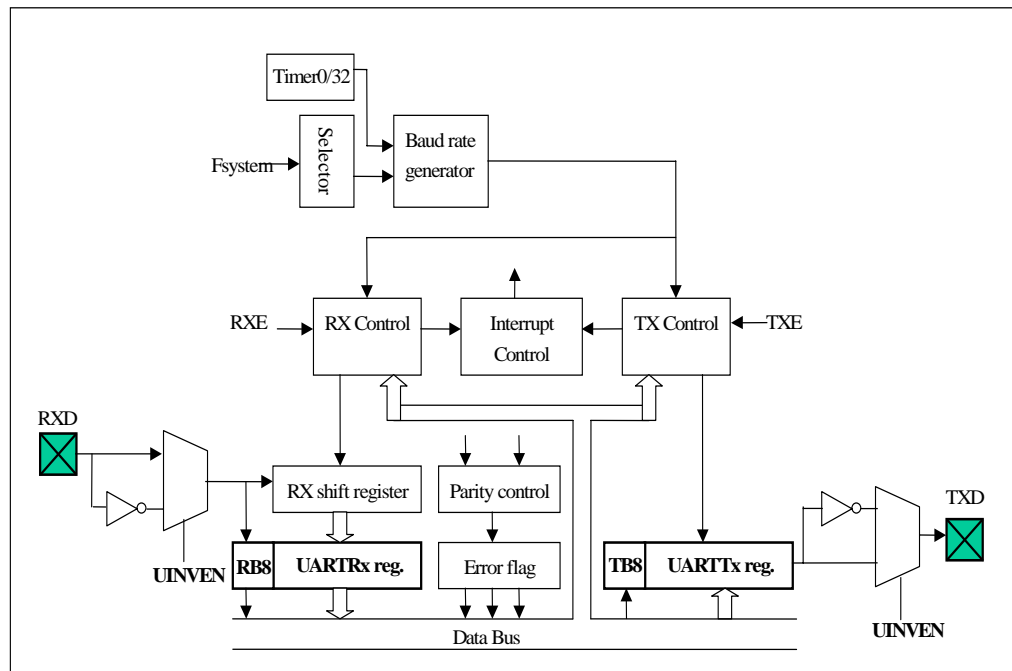

Fig. 8-6 UART Function Block Diagram

In Universal Asynchronous Receiver Transmitter (UART), each transmitted or received character is individually synchronized by framing it with a start bit and stop bit.

Full duplex data transfer is possible because the UART has independent transmit and receive sections. Double buffering in both sections enable the UART to be programmed for continuous data transfer.

The figure below shows the general format of one character sent or received. The communication channel is normally held in the marked state (high). Character transmission or reception starts with a transition to the space state (low).

The first bit transmitted or received is the start bit (low). It is followed by the data bits, in which the least significant bit (LSB) comes first. The data bits are followed by the parity bit. If present, then the stop bit or bits (high) confirm the end of the frame.

In receiving, the UART synchronizes on the falling edge of the start bit. When two or more “0”s are detected during three sampling, it is recognized as a normal start bit and receiving operation is started.

### 8.6.1 Data Format in UART

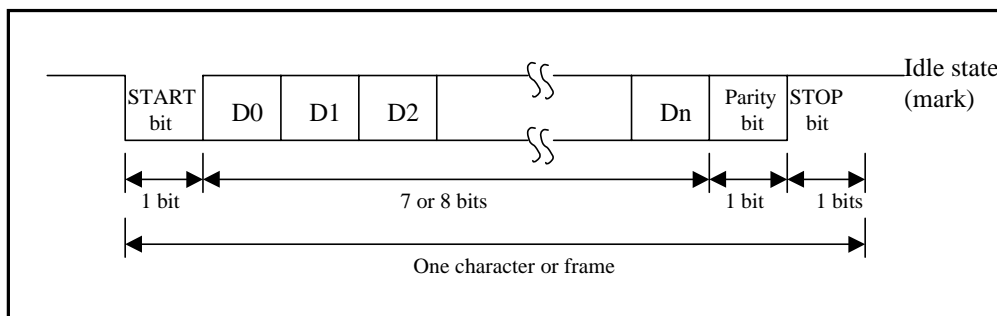

Fig. 8-7 UART Data Format Diagram

### 8.6.2 UART Modes

There are three modes in UART. Mode 1 (7 bits data) and Mode 2 (8 bits data) allow the addition of a parity bit. The parity bit addition is not available in Mode 3. The Figure below shows the data format in each mode.

	UMODE	PRE	1	2	3	4	5	6	7	8	9	10	11	
Mode 1	0	0	START	7 bits DATA							STOP			
		1	START	7 bits DATA							Parity	STOP		
Mode 2	0	1	START	8 bits DATA								STOP		
		1	START	8 bits DATA								Parity	STOP	
Mode 3	1	0	X	START	9 bits DATA									STOP

Fig. 8-8 UART Modes Data Format

### 8.6.3 UART Transmit Data

In transmitting serial data, the UART operates as follows.

1. Set the **TXE** bit of the UARTCON register to enable UART transmission function.
2. Write data into the UARITX register, and the **TBE** bit of the UARTCON register will be set by hardware. Then start transmitting.
3. Serially transmitted data are transmitted in the following order from the TXD pin.
  - (a) Start bit: one “0” bit is output
  - (b) Transmit data: 7, 8, or 9 bits data are output from LSB to MSB
  - (c) Parity bit: one parity bit (odd or even selectable) is output

- (d) Stop bit: one "1" bit (stop bit) is output
  - (e) Mark state: output "1" continues until the start bit of the next transmit data
4. After transmitting the stop bit, the UART generates a **UTXI** interrupt (if enabled)

#### 8.6.4 UART Receive Data

1. Set the **RXE** bit of the UARTCON register to enable the UART receiving function.
2. The UART monitors the RXD pin and synchronizes internally when it detects a start bit.
3. Received data is shifted into the UARTRX register in LSB to MSB sequence.
4. The parity bit and the stop bit are received. After one character is received, the UART generates a **URXI** interrupt (if enabled). Then the **URBF** bit of UARTSTA register will be set to 1.
5. The UART makes the following checks:
  - a) Parity check: The number of "1" in the receive data must match with the even or odd parity setting of the **EVEN** bit in the UARTSTA register.
  - b) Frame check: The start bit must be "0" and the stop bit must be "1."
  - c) Overrun check: the **URBF** bit of the UARTCON register must be cleared (i.e., the UARTRX register should be read out) before the next received data are loaded into the UARTRX register.

If any checks failed, the UERRI interrupt will be generated (if enabled). And the error flag is indicated in **PRERR**, **OVERR** or **FMERR** bit. The error flag should be cleared by software, otherwise, a UERRI interrupt will occur when the next byte is received.

6. Read the received data from the UARTRX register. The **URBF** bit will be cleared by hardware.

#### 8.6.5 UART Baud Rate Generator

- The baud rate generator comprises of a circuit that generates a clock pulse which determines the transfer speed of transmitted/received data in the UART.
- The input clock of the baud rate generator is derived from system clock divided by 64 or from Timer 0 divided by 32.
- The system clock should be at 9.830MHz (PFS = 150) when UART is enabled.
- The BRATE2 ~ BRATE0 bit of the UARTCON register can determine the desired baud rate.

### 8.6.6 UART Applicable Registers

■ **UARTCON (R30h):** UART Control Register

Bit 7	Bit 6	Bit 5	Bit 4	Bit 3	Bit 2	Bit 1	Bit 0
TB8	UMODE1	UMODE0	BRATE2	BRATE1	BRATE0	UTBE	TXE

**Bit 0 (TXE):** Enables transmit data function

**Bit 1 (UTBE):** UART transfer buffer empty flag. Set to “1” when the transfer buffer is empty. Reset to “0” automatically when writing into the UARTTX register.

**NOTE**

*When transmit data is enabled, the UTBE (read-only) bit will be cleared by hardware. Hence, writing to the UARTTX register is required when user wants to start transmitting data.*

**Bit 4 ~ Bit 2 (BRATE 2 ~ 0):** Baud Rate Selector

BRATE 2 ~ 0	Fsystem (PFS = 4 ~ 255)	Fsystem = 9.83MHz (PFS = 150)
000	Timer 0/32	Timer 0/32
001	Fsystem/4096 baud	2400 baud
010	Fsystem/2048 baud	4800 baud
011	Fsystem/1024 baud	9600 baud
100	Fsystem/512 baud	19200 baud
101	Fsystem/256 baud	38400 baud
110	Fsystem/128 baud	76800 baud
111	Fsystem/64 baud	153600 baud

**Bit 6 ~ Bit 5 (UMODE 1 ~ 0):** UART Mode

UMODE 1: UMODE 0	UART Mode
00	Mode 1: 7-bit data
01	Mode 2: 8-bit data
10	Mode 3: 9-bit data
11	Reserved

**Bit 7 (TB8):** Transmission Data Bit 8

■ **UARTSTA (R31h):** UART STATUS Register

Bit 7	Bit 6	Bit 5	Bit 4	Bit 3	Bit 2	Bit 1	Bit 0
RB8	EVEN	PRE	PRERR	OVERR	FMERR	URBF	RXE

**Bit 0 (RXE):** Enable receive data function

**Bit 1 (URBF):** UART read buffer full flag. Set to 1 when one character is received.  
Reset to 0 automatically when read from the UARTRX register.

**NOTE**

*When receive data is enabled, URBF (read-only) bit will be cleared by hardware. Hence, reading from the UARTRX register is required to avoid overrun error.*

**Bit 2 (FMERR):** Framing error flag. Set to 1 when framing error occurs  
Clear to 0 by software

**Bit 3 (OVERR):** Overrun error flag. Set to 1 when overrun error occurs  
Clear to 0 by software

**Bit 4 (PRERR):** Parity error flag. Set to 1 when parity error occurs  
Clear to 0 by software

**Bit 5 (PRE):** Enable parity addition  
"0" : Disable  
"1" : Enable

**Bit 6 (EVEN):** Select parity check  
"0" : Odd parity  
"1" : Even parity

**Bit 7 (RB8):** Receiving Data Bit 8

■ **UARTTX (R15h):** UART Transfer Register

Bit 7	Bit 6	Bit 5	Bit 4	Bit 3	Bit 2	Bit 1	Bit 0
TB7	TB6	TB5	TB4	TB3	TB2	TB1	TB0

**Bit 7 ~ Bit 0 (TB7 ~ TB0):** Transmission data register. UARTTX register is write-only.

■ **UARTRX (R16h):** UART Receiver Register

Bit 7	Bit 6	Bit 5	Bit 4	Bit 3	Bit 2	Bit 1	Bit 0
RB7	RB6	RB5	RB4	RB3	RB2	RB1	RB0

**Bit 7 ~ Bit 0 (RB7 ~ RB0):** Receiving data register. UARTRX register is read-only.



■ **STBCON (R21h):** Strobe Output Control Register

Bit 7	Bit 6	Bit 5	Bit 4	Bit 3	Bit 2	Bit 1	Bit 0
UINVEN	/REN	BitST	ALL	STB3	STB2	STB1	STB0

**Bit 7 (UINVEN):** Enable UART **TXD** and **RXD** port inverse output.

“0” : Disable **TXD** and **RXD** port inverse output.

“1” : Enable **TXD** and **RXD** port inverse output.

■ **CPUCON (R0Eh):** MCU Control Register

Bit 7	Bit 6	Bit 5	Bit 4	Bit 3	Bit 2	Bit 1	Bit 0
PEN	-	-	SMCAND	SMIER	GLINT	MS1	MS0

**Bit 2 (GLINT):** Global Interrupt Control Bit

“0” : Disable all interrupts

“1” : Enable all un-masked interrupt

■ **INTCON (R22h):** Interrupt Control Register

Bit 7	Bit 6	Bit 5	Bit 4	Bit 3	Bit 2	Bit 1	Bit 0
CPIE	ADIE	URXIE	UTXIE	UERRIE	TMR2IE	TMR1IE	TMR0IE

**Bit 3 (UERRIE):** Control bit of UART receiving error interrupt

“0” : Disable

“1” : Enable

**Bit 4 (UTXIE):** Control bit of UART Transfer buffer empty interrupt

“0” : Disable

“1” : Enable

**Bit 5 (URXIE):** Control bit of UART Receiver buffer full interrupt

“0” : Disable

“1” : Enable

■ **INTSTA (R23h):** Interrupt Status Register

Bit 7	Bit 6	Bit 5	Bit 4	Bit 3	Bit 2	Bit 1	Bit 0
CPIF	ADIF	URXI	UTXI	UERRI	TMR2I	TMR1I	TMR0I

**Bit 3 (UERRI):** Set to 1 when UART receiving error occurs

Clear to 0 by software or disable UART

**Bit 4 (UTXI):** Set to 1 when UART transfer buffer empty occurs

Clear to 0 by software or disable UARTTX (TXE=0)

**Bit 5 (URXI):** Set to 1 when UART receiver buffer full occurs

Clear to 0 by software or disable UARTRX (RXE=0)

### 8.6.7 Transmit Counter Timing

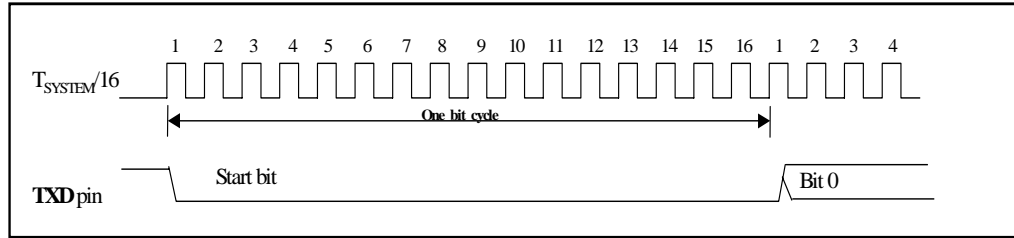

Fig. 8-9 UART Transmit Counter Timing

### 8.6.8 UART Transmit Operation (8-Bit Data with Parity Bit)

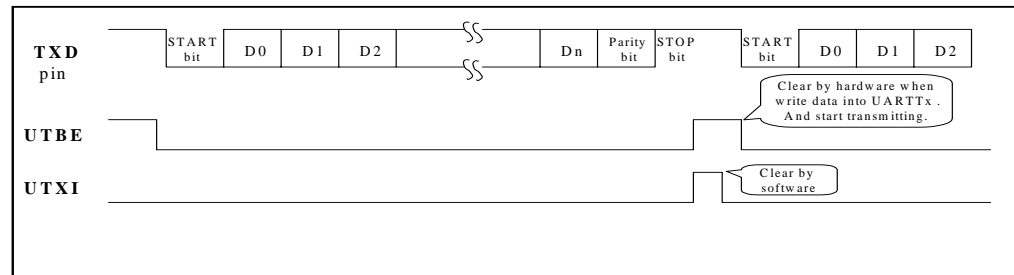

Fig. 8-10 UART Transmit Operation

#### Code Example:

```

; === UART Transfer buffer empty interrupt
PERIPH:
    PUSH
    JBC     INTSTA,UTXI,Q_UTXINT
    BC     INTSTA,UTXI
    MOV    A,UTX_NO
    COMA   ACC
    MOV    UTX_NO,A
    MOV    UARTTX,A           ;Tx data 55,AA,55,AA
Q_UTXINT:
    POP
    RETI
; === UART 38400 baud 8bit inverse
UTX_SR:
    :
    System setting 9.83MHz
    :
    BS     STBCON,UINVEN      ; TXD & RXD inverse
    MOV    A,#00110101B      ; Enable Tx
    MOV    UARTCON,A         ; 8bit, 38400baud
    MOV    A,#01100000B      ; Disable Rx
    MOV    UARTSTA,A         ; Even Parity
    BC     INTSTA,UTXI       ; TX buffer empty occur
    BS     INTCON,UTXIE      ; En. TX interrupt
    BS     CPUCON,GLINT      ; Global interrupt
    MOV    A,#0X55
    MOV    UTX_NO,A
    MOV    UARTTX,A         ; Tx data 55
TX_loop:
    SJMP   TX_loop
    
```

### 8.6.9 Receive Counter Timing

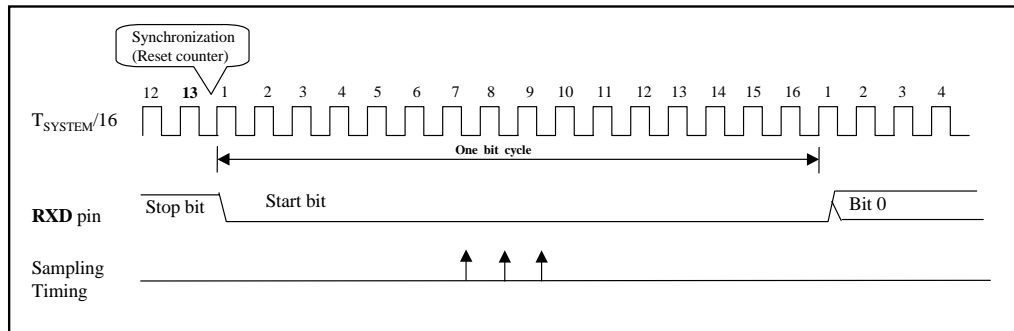

Fig. 8-11 UART Receive Counter Timing

UART Receive operation (8 bits data with parity and stop bit):

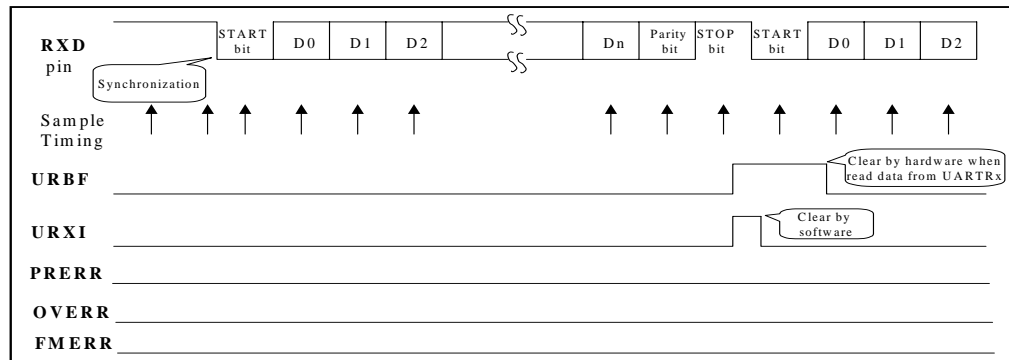

Fig. 8-12 UART Receive Operation

**Code Example:**

```

;===UART Receiver buffer full interrupt
PERIPH:
    PUSH
    JBC     INTSTA,URXI,UERRINT
    BC     INTSTA,URXI
    MOVPR  URX_NO,UARTRX
    SJMP   Q_RXINT
;
;===UART error interrupt
UERRINT:
    JBC     INTSTA,UERRI,Q_RXINT
    BC     INTSTA,UERRI
;---Framing error flag
;---Over run error flag
;---Parity error flag
    MOV    A,UARTSTA
    AND    A,#00011100B
    MOV    PORTH,A
    BC    UARTSTA,FMERR
    BC    UARTSTA,OVERR
    BC    UARTSTA,PRERR
Q_RXINT:
    POP
    RETI

;===UART 38400 baud 8bit inverse
URX_SR:
    :
    System setting 9.83MHz
    Port H & G setting output port
    :
;---TXD & RXD inverse
    BS     STBCON,UINVEN
;---Disable Tx, 8bit, 38400baud
    MOV    A,#00110100B
    MOV    UARTCON,A
;---Enable Rx, Even Parity
    MOV    A,#01100001B
    MOV    UARTSTA,A
;---UART RX buffer empty interrupt
    BS     INTSTA,URXI
    BS     INTCON,URXIE
;---UART RX error interrupt
    BS     INTSTA,UERRI
    BS     INTCON,UERRIE
;---Global interrupt
    BS     CPUCON,GLINT
RX_loop:
    MOVPR  PORTG,URX_NO
    SJMP   RX_loop

```

## 8.7 A/D Converter

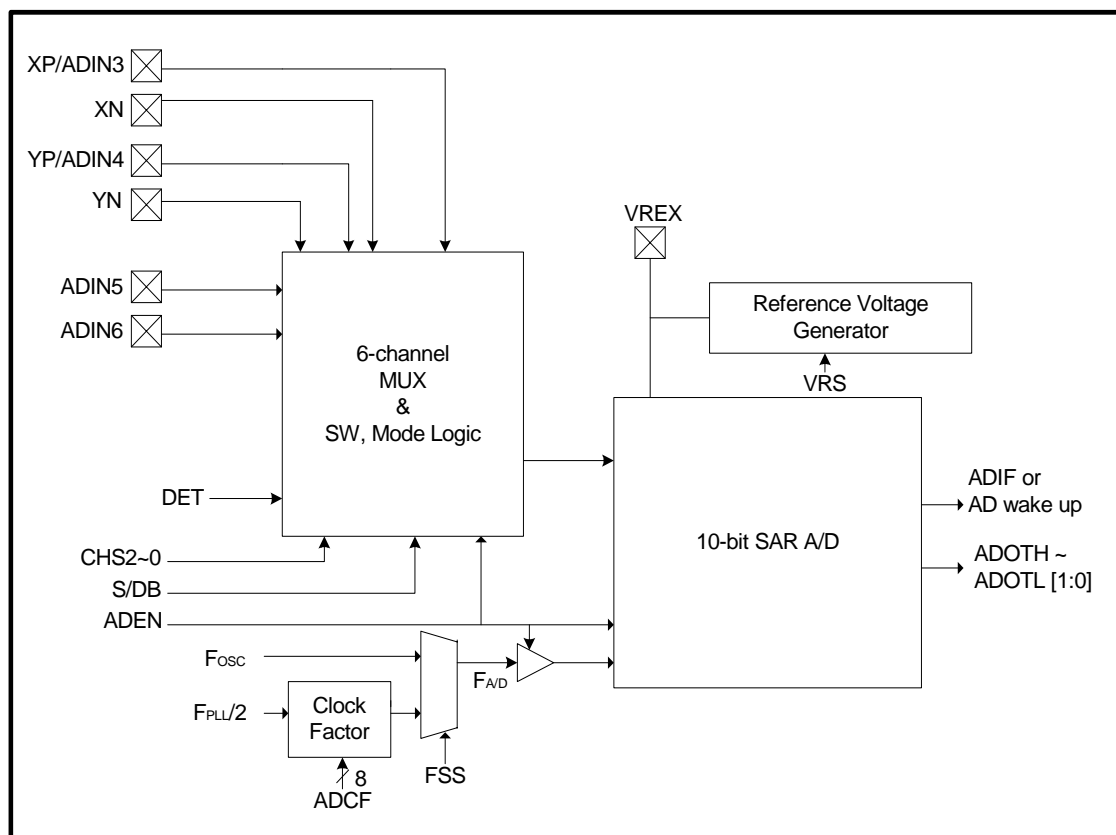

Fig. 8-13 A/D Converter Function Block Diagram

- VREX:** Reference voltage I/O pin  
When VRS=1; it is input pin  
When VRS=0, it is output pin
- XN (Port C.7):** X negative position input
- YN (Port C.6):** Y negative position input
- XP/ADIN3 (Port C.5):** X positive position input or A/D input Channel 3
- YP/ADIN4 (Port C.4):** Y positive position input or A/D input Channel 4
- ADIN5 (Port C.3):** A/D converter input Channel 5
- ADIN6 (Port C.2):** A/D converter input Channel 6

This A/D has 6 channels and 10-bit resolution. When the MCU is in SLOW or FAST mode and ADEN=1, A/D conversion runs immediately. The two channels: XP and YP have low resistance switches for driving the touch screens. The other 4 channels are for general application.

The A/D converter operation for touch panel application is as follows:

**Step 1:** Pen down detection

If the panel is not touched, the PIRQB is high. When the touch panel is pressed, the PIRQB is low and PIRQB interrupt occurs (if INT is enabled).

**Step 2:** Measure the X position

If the PIRQB is remains low for a period of time, the DET bit is cleared, then PIRQB returns to high and the X position is measured.

**Step 3:** Measure the Y position

The Y position is measured immediately after step 2.

**Step 4:** Back to Step 1

**8.7.1 A/D Converter Applicable Registers**

■ **ADCON (R2Ch):** A/D Control Register

Bit 7	Bit 6	Bit 5	Bit 4	Bit 3	Bit 2	Bit 1	Bit 0
DET	VRS	ADEN	PIRQB	S/DB	CHS2	CHS1	CHS0

**Bit 2 ~ Bit 0 (CHS2 ~ CHS0):** 2-channel touch screen & 4-channel A/D input selection.

**Bit 3 (S/DB):** Reference mode control bit

“0” : Differential reference mode

“1” : Single-ended reference mode

**Bit 4 (PIRQB):** Touch screen status bit. It is a read bit

“0” : Touch screen is tapped

“1” : Touch screen is not tapped

**Bit 5 (ADEN):** A/D enable control bit. Automatically clears to “0” when ADIF occurs.

“0” : A/D disabled

“1” : A/D enabled

**Bit 6 (VRS):** A/D input reference voltage selection and enable/disable internal reference generator bit

“0” : Enable the internal reference generator and the reference voltage is from the internal reference voltage generator

“1” : Disable the internal reference generator and the reference voltage is from the external VREX pin



**Bit 7 (DET):** Touch panel pen down detection mode control bit. Enables/disables PIRQB interrupt and wake-up functions  
 “0” : Disable the detection mode. S switches are off for interrupts and wake-up functions  
 “1” : Enable the detection mode. S switches are on for interrupts and wake-up functions

ADEN	DET	CHS [2:0]	Vin	VRS	Mode
0	0	-	-	1	Standby mode
0	1	-	-	1	Pen-down detection
1	0	000	YP	1	Measure X position (Touch panel)
1	0	001	XP	1	Measure Y position (Touch panel)
1	0	010	ADIN3	0/1	Measure ADIN3
1	0	011	ADIN4	0/1	Measure ADIN4
1	0	100	ADIN5	0/1	Measure ADIN5
1	0	101	ADIN6	0/1	Measure ADIN6

■ **ADOTH (R14h):** A/D Output High Byte Register

Bit 7	Bit 6	Bit 5	Bit 4	Bit 3	Bit 2	Bit 1	Bit 0
ADOT9	ADOT8	ADOT7	ADOT6	ADOT5	ADOT4	ADOT3	ADOT2

■ **ADOTL (R13h):** A/D Output Low Byte Register

Bit 7	Bit 6	Bit 5	Bit 4	Bit 3	Bit 2	Bit 1	Bit 0
WDTEN	-	ADWKEN	-	-	FSS	ADOT1	ADOT0

**Bit 7H ~ Bit 0H ~ Bit 1L ~ Bit 0L (ADOT9 ~ ADOT0):** 10-bit resolution A/D output data.

**Bit 2 (FSS):** A/D clock source select bit

“1” : A/D clock source is from FPLL/2

“0” : A/D clock source is from Fosc

**NOTE**

*When MCU is in FAST mode, the A/D clock source must be from PLL (FSS = 1, PEN = 1). Sourcing A/D clock from Oscillator (FSS = 0, PEN = 0) is prohibited.*

**Bit 5 (ADWKEN):** A/D wake up control bit

“1” : Enable A/D wake-up function

“0” : Disable A/D wake-up function

■ **ADCF (R4Eh):** A/D Clock Factor Register

The ADCF is used as a clock factor, such as:

$$F_{A/D} = \frac{F_{PLL}}{2(ADCF + 1)}$$

A/D Throughput rate =  $F_{A/D}/12$

	FPLL=2.03M (PFS=31)	FPLL=3.99M (PFS=61)	FPLL=7.99M (PFS=122)	FPLL=9.83M (PFS=150)
ADCF=3	FA/D=254k	FA/D=499k	FA/D=999k	FA/D=1229k
ADCF=7	FA/D=127k	FA/D=250k	FA/D=499k	FA/D=614k
ADCF=15	FA/D=63k	FA/D=125k	FA/D=250k	FA/D=307k
ADCF=31	FA/D=31k	FA/D=62k	FA/D=125k	FA/D=154k
ADCF=63	FA/D=15k	FA/D=31k	FA/D=62k	FA/D=77k
ADCF=95	FA/D=11k	FA/D=21k	FA/D=42k	FA/D=60k
ADCF=127	FA/D=10k	FA/D=21k	FA/D=31k	FA/D=51k
ADCF=159	FA/D=6k	FA/D=12k	FA/D=25k	FA/D=31k
ADCF=191	FA/D=5k	FA/D=10k	FA/D=21k	FA/D=25k
ADCF=223	FA/D=4.5k	FA/D=8.9k	FA/D=17.8k	FA/D=21.9k
ADCF=255	FA/D=3.9k	FA/D=7.8k	FA/D=15.6k	FA/D=19.2k

**NOTE**  
Any FA/D value greater than 1.4MHz is invalid.

■ **CPUCON (R0Eh):** MCU Control Register

Bit 7	Bit 6	Bit 5	Bit 4	Bit 3	Bit 2	Bit 1	Bit 0
PEN	-	-	SMCAND	SMIER	GLINT	MS1	MS0

**Bit 0 (MS0):** CPU Fast/Slow mode setting

“0” : Slow mode

“1” : Fast mode

**Bit 1 (MS1):** CPU Sleep & Idle mode setting

“0” : Sleep mode

“1” : Idle mode

**Bit 2 (GLINT):** Global interrupt control bit

“0” : Disable all interrupts

“1” : Enable all un-mask interrupts

**Bit 7 (PEN):** PLL enable (only effective when the MCU is in IDLE or SLOW mode)

“0” : Disable PLL

“1” : Enable PLL

■ **INTCON (R22h):** Interrupt Control Register

Bit 7	Bit 6	Bit 5	Bit 4	Bit 3	Bit 2	Bit 1	Bit 0
CPIE	ADIE	URXIE	UTXIE	UERRIE	TMR2IE	TMR1IE	TMR0IE

**Bit 6 (ADIE):** A/D interrupt control bit

“0” : Disable

“1” : Enable

■ INTSTA (R23h): Interrupt Status Register

Bit 7	Bit 6	Bit 5	Bit 4	Bit 3	Bit 2	Bit 1	Bit 0
CPIF	ADIF	URXI	UTXI	UERRI	TMR2I	TMR1I	TMR0I

**Bit 6 (ADIF):** Set to 1 when A/D output data is ready to be read  
Cleared to "0" by software or disable A/D

### 8.7.2 Timing Diagram of General A/D Converter Application

CHS [2:0] = 010 ~ 101

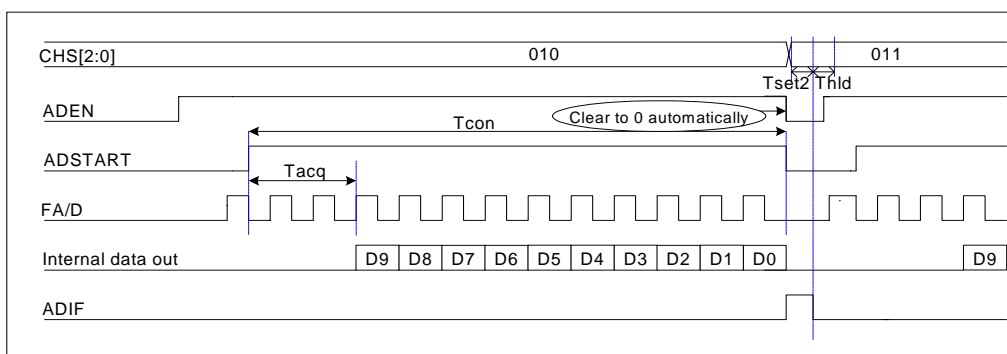

Fig. 8-14 A/D Converter General Application Timing Diagram

### 8.7.3 Correlation between A/D Converter and MCU Mode

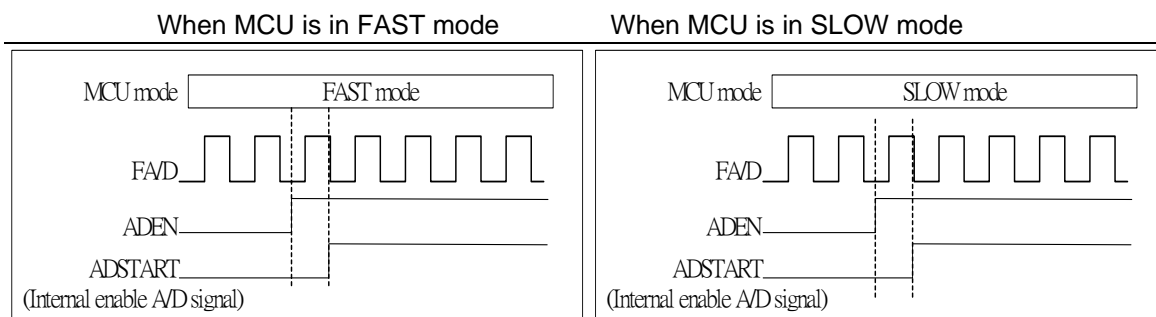

Fig. 8-15 A/D Converter vs. MCU Mode

**Code Example:**

```

;===A/D interrupt
PERIPH:
    PUSH
    JBC     INTSTA,ADIF,Q_ADINT
    BC     INTSTA,ADIF
    BS     INTFLAG,F_IAD
Q_ADINT:
    POP
    RETI
;=== Fpll=8MHz & ADCF=7 => FA/D=499kHz
AD_SR:
    :
    System setting 8MHz
    Port H & G setting output port
    :
;---PLL enable
    BS     CPUCON,PEN
;---Clock source is PLL
    BS     ADOTL,FSS
;---FA/D=499kHz
    MOV     A,#7
    MOV     ADCF,A
;---VRIN, Differential, ADIN3
    MOV     A,#00000010B
    MOV     ADCON,A
;---AD interrupt enable
    BS     INTCON,ADIE
    BC     INTSTA,ADIF
    BS     CPUCON,GLINT
;===Fast mode: MCU in fast mode
    BS     CPUCON,MS1
;--- Repeat detect A/D 3 times
    MOV     A,#3
AD3times:
;---AD enable
    BS     ADCON,ADEN
Chk_AD:
    JBC     INTFLAG,F_IAD,Chk_AD
    BC     INTFLAG,F_IAD
    JDNZ    ACC,AD3times
;===Slow mode: MCU in slow mode
    BC     CPUCON,MS0
;---Repeat detect A/D 3 times
    MOV     A,#3
AD3times:
;---AD enable
    BS     ADCON,ADEN
Chk_AD:
    JBC     INTFLAG,F_IAD,Chk_AD
    BC     INTFLAG,F_IAD
    JDNZ    ACC,AD3times
;---Out AD to Port H : G
    MOV     PORTH,ADOTL
    MOV     A,ADOTL
    AND     A,#00000011B
    MOV     PORTG,A
    :

```

### 8.7.4 A/D Converter Flowchart

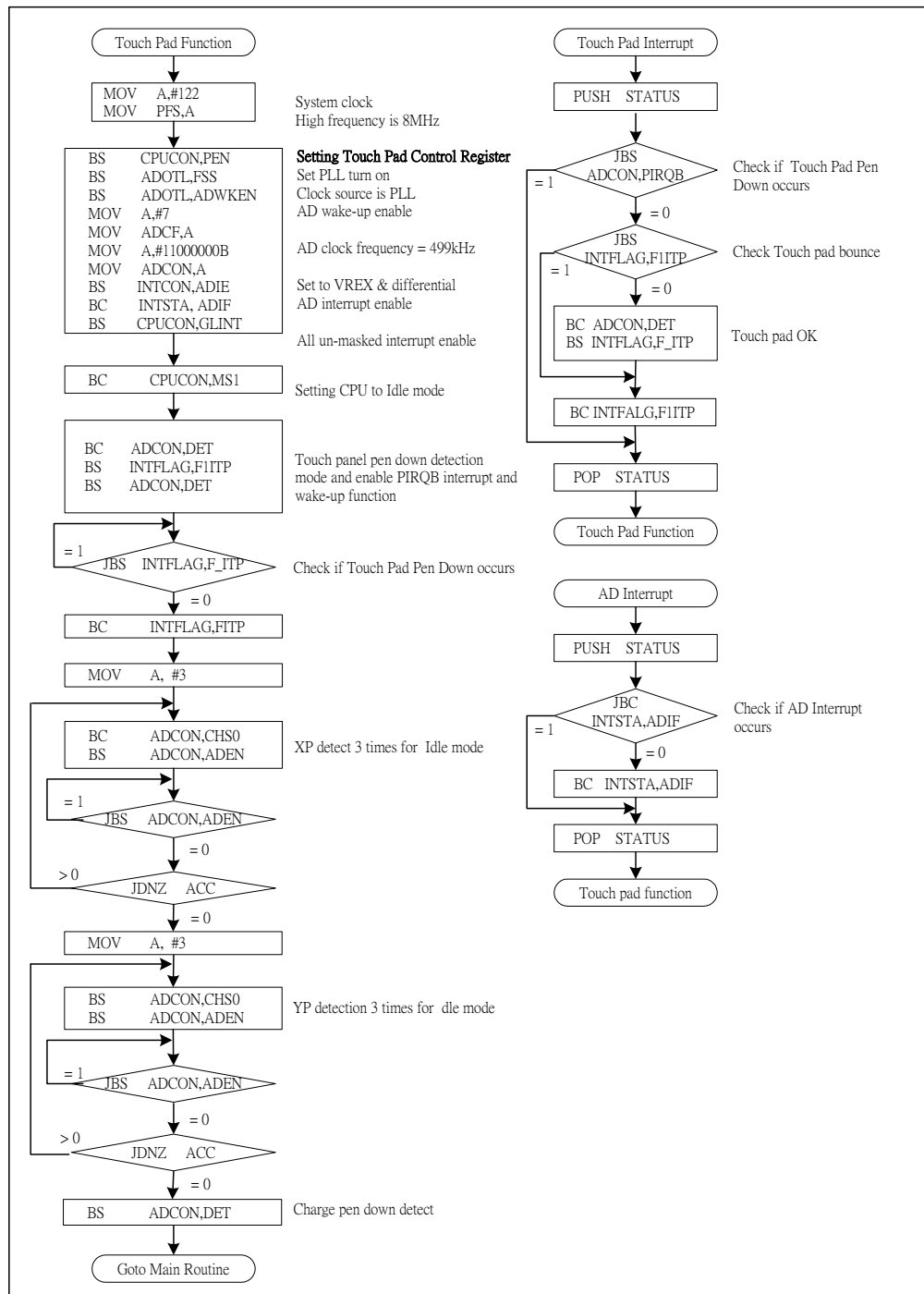

#### Code Example

```

; *** Touch panel Interrupt
INPTINT:
    PUSH
    JBS    ADCON,PIRQB,Q_TPINT    ; Touch screen status bit
    JBS    INTFLAG,FITP,TPINT1
    BC     ADCON,DET              ; Pen down detection disable
    BS     INTFLAG,F_ITP         ; Pen down ok flag
    
```

```

TPINT1:
    BC        INTFLAG,F1ITP           ; Pen down detect 2 times
Q_TPINT:
    POP
    RETI
; === A/D interrupt
PERIPH:
    PUSH
    JBC       INTSTA,ADIF,Q_ADINT
    BC        INTSTA,ADIF
Q_ADINT:
    POP
    RETI
; === Touch panel routine
TP_SR:
    :
    System setting 8MHz
    Port H & G setting output port
    :
    BS        CPUCON,PEN               ; PLL enable
    BS        ADOTL,FSS                ; Clock source is PLL
    BS        ADOTL,ADWKEN             ; AD wake-up
    MOV       A,#7
    MOV       ADCF,A                   ; FA/D=499kHz
    MOV       A,#11000000B
    MOV       ADCON,A                  ; VREX, Differential
    BS        INTCON,ADIE              ; AD interrupt enable
    BC        INTSTA,ADIF
    BS        CPUCON,GLINT
TPILoop:
    BC        ADCON,DET                 ; Pen down detection disable
    BS        INTFLAG,F1ITP
    BS        ADCON,DET                 ; Pen down detection enable
TPILp1:
    JBS       INTFLAG,F_ITP,TPILp1
; --- Repeat YP detect A/D 3 times
    MOV       A,#3
YP3times:
    BS        ADCON,CHS0                ; YP detection
    BS        ADCON,ADEN                ; AD enable
WaitYAD:
    JBS       ADCON,ADEN,WaitYAD
    JDNZ     ACC,YP3times
    MOV      PORTG,ADOTH
; --- Repeat XP detect A/D 3 times
    MOV       A,#3
XP3times:
    BC        ADCON,CHS0                ; XP detection
    BS        ADCON,ADEN                ; AD enable
WaitXAD:
    JBS       ADCON,ADEN,WaitXAD
    JDNZ     ACC,XP3times
    MOV      PORTH,ADOTH
    BS        ADCON,DET
    :
    SJMP     TPILoop

```

## 8.8 Key I/O

The 7-pin key input (Port A0~6) and 16-pin key strobe (share with LCD SEG0~15) can achieve a maximum 112-key matrix.

### 8.8.1 Automatic Key Scan or Software Key Scan

Interrupt is enabled when in automatic key scan (**SCAN=1**). Wake-up is also enabled when key input falling edge is detected at automatic key scan mode (**SCAN=1**).

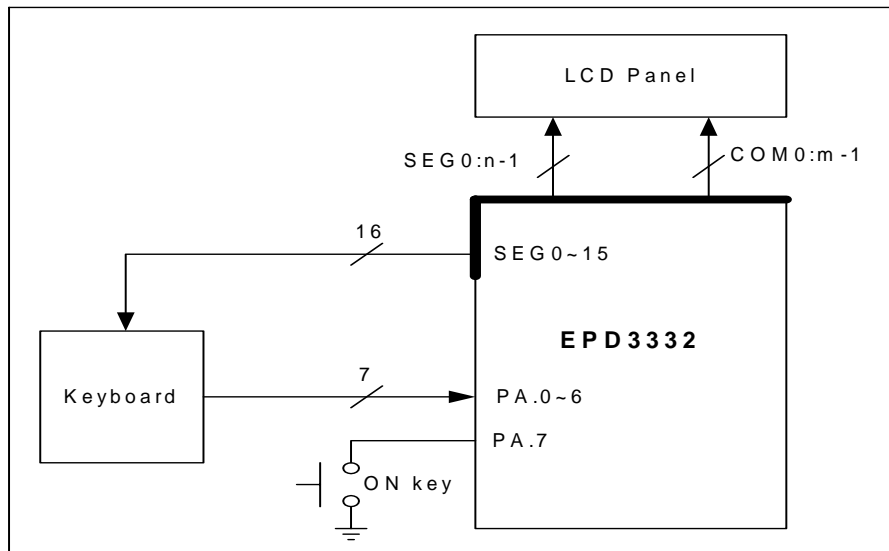

Fig. 8-17 Keyboard Function Block Diagram

As shown in the figure, it is taken into consideration that the Key strobe output has resistance  $R_{ON}$ , as well as each key has resistance  $K_{ON}$  and capacitance  $C$ . Since a prolong strobe output makes an LCD display confusing, strobe output should be as short as possible. So  $R_{IN}$  (pull-up resistance) should be low enough for the capacitance to be charged quickly. But  $R_{IN}$  should be high enough for  $V_{IN}$  to be ascertained in "L" level. ( $R_{IN} \gg R_{ON} + K_{ON}$ ) Hence, the value of  $R_{IN}$  should be flexible.

The following are the "Key input process":

1. Output the strobe signal
2. Pull up the input port by lowest resistance ( $R_1$  and  $R_2$  enabled): Capacitance is charged quickly.
3. Pull up the input port by highest resistance (only  $R_2$  is enabled).
4. Read the key
5. Disable the pulled-up resistance
6. Stop the strobe signal

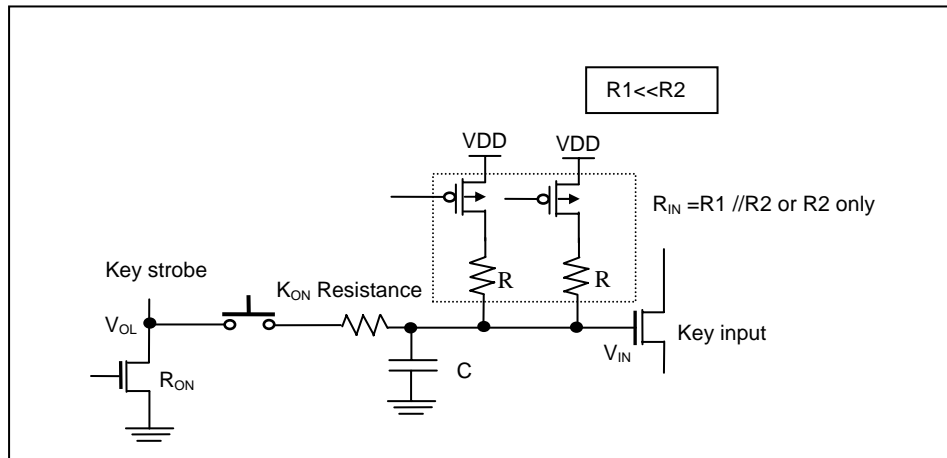

Fig. 8-18 Key Circuit Diagram

The detailed function is summarized in the following table:

SCAN	BitST	KE	/R1EN	/R2EN	SSCAN <sup>1</sup>	SCAN <sup>1</sup>	IEN <sup>1</sup>	Total Pull-up Resistor	Port A.0~6	Note		
0	0	×	1	1	0	0	0	Floating	0			
			1	1				0	Floating		0	A
			1	0				0	R2		0	
			0	1				0	R1		0	
			0	0				0	R1 // R2 <sup>2</sup>		0	B
	1	1	×	1	1	0	0	1	Floating	Floating	Prohibited	
				1	0				1	R2	PA.0~6	C
				0	1				1	R1	PA.0~6	
				0	0				1	R1 // R2 <sup>2</sup>	PA.0~6	
				1	1				1	R2	PA.0~6	
1	×	×	1	1	0	0	0	Floating	0	A		
			0	0	0	1	0	R1//R2 <sup>2</sup>	0	B		
			1	0	1	1	1	R2	PA.0~6	C		

<sup>1</sup> Internal signal - Refer to the "Automatic Key Scan Timing"

<sup>2</sup>  $R1 // R2 = R1R2 / (R1+R2)$

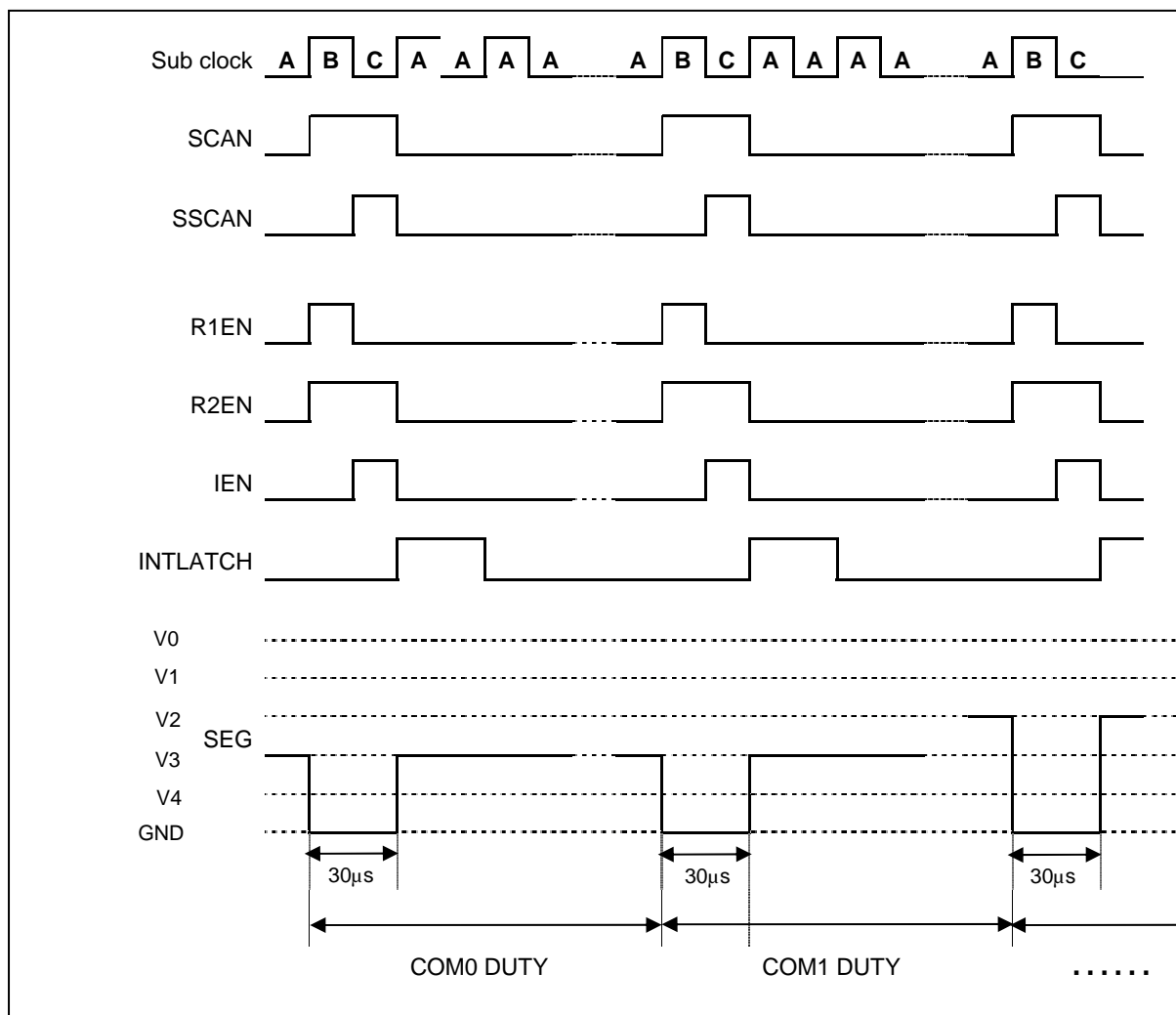

Fig. 8-19 Automatic Key Scan Timing Diagram (SCAN = 1)

The Key strobe pin shares with the LCD segment pin in the CPU with embedded LCD driver model.

When pin-shared with an LCD segment, to avoid having a confusing LCD display, the strobe output should be as short as possible.

There are two ways to output a strobe signal:

#### ◇ Automatic Key Scan

The LCD waveform has a 30µs low pulse at the beginning of every common duty signal by setting the **SCAN** bit of the STBCON register. The strobe timing is as shown in the figure.

When in automatic key scan mode, the PAINT or Port A wake-up must be enabled. During Key scan, wake-up and interrupt will occur if key input pin (Port A) falling edge is detected.

✧ **Software Key Scan**

Segment is switched to strobe signal temporarily by setting the **BitST** bit of the STBCON register to 1 and the **SCAN** bit to 0.

Setup the **STB3~STB0** bits of the STBCON register to select which pin will be strobes.

In this mode user can set **ALL** bits of the STBCON register to let Segments 0~15 to be kept at GND level.

**In IDLE MODE**, during automatic key scanning, if PA.0~7 pin falling edge is detected (when IEN=1), wake-up will occur. Then the CPU runs and interrupt occurs (If enabled).

**In SLOW MODE or FAST MODE**, both automatic key scan and software key scan will be used.

Automatic key scan will be used to examine **If there is any key pressed?** If a key is pressed, PA.0~7 pin falling edge is detected, then an **interrupt will occur**.

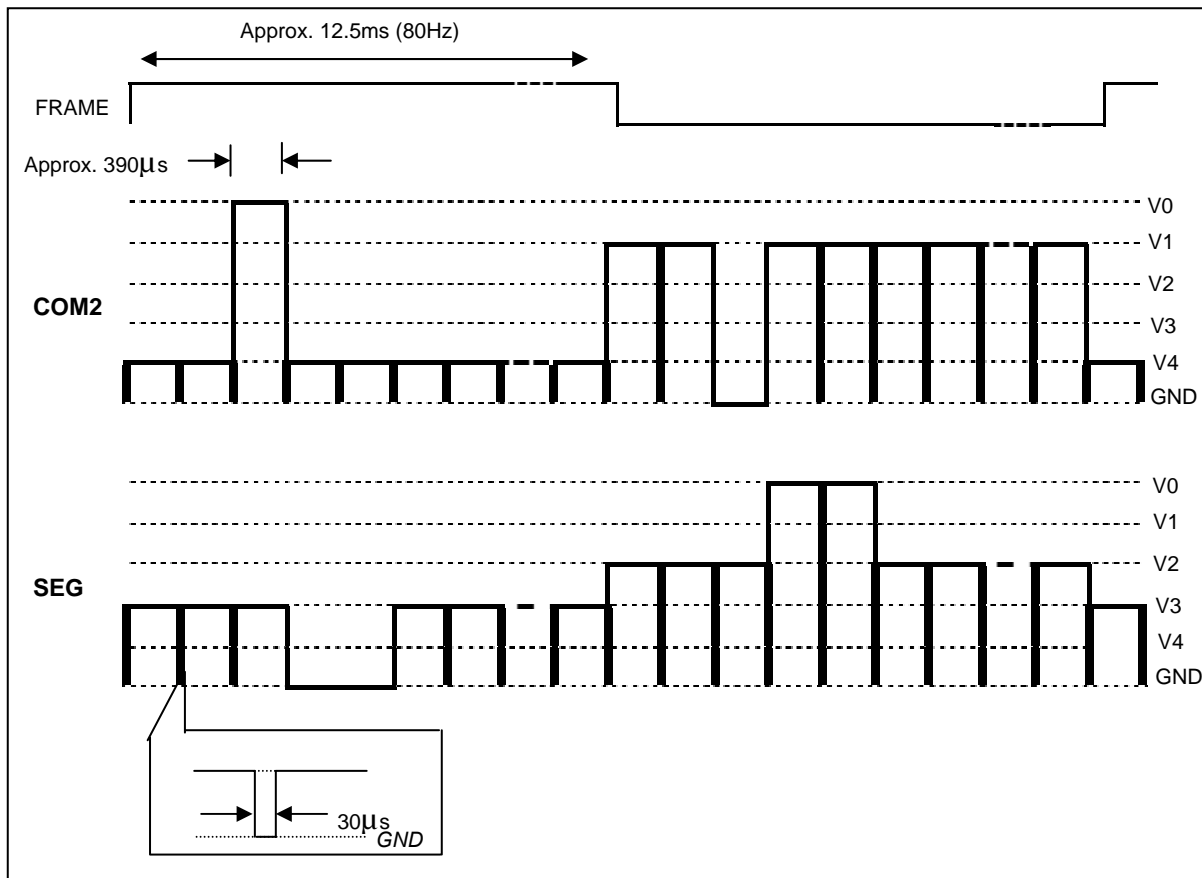

Fig. 8-20 Automatic Strobe Signal (SCAN = 1)



Software key scan will examine “which key was pressed”.

The key strobe pin function is as shown in the following table:

STBCON			Key Strobe (Share with Segment 0~15)															LCD					
SCAN	BitST	ALL	STB3~0	seg 0	seg 1	seg 2	seg 3	seg 4	seg 5	seg 6	Seg 7	seg 8	seg 9	seg 10	Seg 11	seg 12	seg 13	seg 14	seg 15	seg 16:n-1	com 0:m-1		
0	0	×	xxxx	Display waveform																			
	1	0	0000	0	1	1	1	1	1	1	1	1	1	1	1	1	1	1	1	1	1	Display waveform	
			0001	1	0	1	1	1	1	1	1	1	1	1	1	1	1	1	1	1	1		1
			0010	1	1	0	1	1	1	1	1	1	1	1	1	1	1	1	1	1	1		1
			0011	1	1	1	0	1	1	1	1	1	1	1	1	1	1	1	1	1	1		1
			0100	1	1	1	1	0	1	1	1	1	1	1	1	1	1	1	1	1	1		1
			0101	1	1	1	1	1	0	1	1	1	1	1	1	1	1	1	1	1	1		1
			0110	1	1	1	1	1	1	0	1	1	1	1	1	1	1	1	1	1	1		1
			0111	1	1	1	1	1	1	1	0	1	1	1	1	1	1	1	1	1	1		1
			1000	1	1	1	1	1	1	1	1	0	1	1	1	1	1	1	1	1	1		1
			1001	1	1	1	1	1	1	1	1	1	0	1	1	1	1	1	1	1	1		1
			1010	1	1	1	1	1	1	1	1	1	1	0	1	1	1	1	1	1	1		1
			1011	1	1	1	1	1	1	1	1	1	1	1	0	1	1	1	1	1	1		1
			1100	1	1	1	1	1	1	1	1	1	1	1	1	0	1	1	1	1	1		1
			1101	1	1	1	1	1	1	1	1	1	1	1	1	1	0	1	1	1	1		1
			1110	1	1	1	1	1	1	1	1	1	1	1	1	1	1	0	1	1	1		1
			1111	1	1	1	1	1	1	1	1	1	1	1	1	1	1	1	1	1	1		0
1	×	×	xxxx	Display waveform with automatic key scan																			

### 8.8.2 Input/Output Key Applicable Registers

■ **Port A (R17h):** Port A Register

Bit 7	Bit 6	Bit 5	Bit 4	Bit 3	Bit 2	Bit 1	Bit 0
PA7	PA6	PA5	PA4	PA3	PA2	PA1	PA0

**Bit 7 ~ Bit 0 (PA7 ~ PA0):** Key input. Input falling edge interrupt or wake up pin.

■ **PAINTEN (R2Dh):** Port A Interrupt Enable Control Register

Bit 7	Bit 6	Bit 5	Bit 4	Bit 3	Bit 2	Bit 1	Bit 0
PA7IE	PA6IE	PA5IE	PA4IE	PA3IE	PA2IE	PA1IE	PA0IE

**Bit 7 ~ Bit 0 (PA7IE ~ PA0IE):** Interrupt control bit

“0” : Disable

“1” : Enable

■ **PAINTSTA (R2Eh): Port A Interrupt Status Register**

Bit 7	Bit 6	Bit 5	Bit 4	Bit 3	Bit 2	Bit 1	Bit 0
PA7I	PA6I	PA5I	PA4I	PA3I	PA2I	PA1I	PA0I

**Bit 7 ~ Bit 0 (PA7I ~ PA0I):** INT status of Port A interrupt.

Set to 1 when pin falling edge is detected

Clear to 0 by software

■ **PAWAKE (R2Fh): Port A Wakeup Control Register**

Bit 7	Bit 6	Bit 5	Bit 4	Bit 3	Bit 2	Bit 1	Bit 0
WKEN7	WKEN6	WKEN5	WKEN4	WKEN3	WKEN2	WKEN1	WKEN0

**Bit 7 ~ Bit 0 (WKEN7 ~ WKEN0):** Control bit of Port A wake-up function

“0” : Disable wake-up function

“1” : Enable wake-up function

■ **PACON (R55h): Port A Control Register**

Bit 7	Bit 6	Bit 5	Bit 4	Bit 3	Bit 2	Bit 1	Bit 0
-	-	-	-	Bit7PU	/R2EN	/R1EN	KE

**Bit 0 (KE):** Key input enable/disable control bit

“0” : Disable Key input function (Port A register does NOT correspond with Key input in software scan mode).

“1” : Enable Key input function (Port A register corresponds with the Key input in software scan mode).

**Bit 1 (/R1EN):** R1 pull-up resistor (small resistor) control bit.

“0” : Enable R1 pull-up resistor

“1” : Disable R1 pull-up resistor

**Bit 2 (/R2EN):** R2 pull-up resistor (large resistor) control bit.

“0” : Enable R2 pull-up resistor

“1” : Disable R2 pull-up resistor

■ **STBCON (R21h): Strobe Output Control Register**

Bit 7	Bit 6	Bit 5	Bit 4	Bit 3	Bit 2	Bit 1	Bit 0
UINVEN	SCAN	BitST	ALL	STB3	STB2	STB1	STB0

**Bit 3 ~ Bit 0 (STB3 ~ STB0):** Strobe output selector bit.

**Bit 4 (ALL):** Set All strobe

“0” : Bit strobe

“1” : All strobe

**Bit 5 (BitST):** Enable Bit strobe

“0” : Display waveform

“1” : Strobe signal as STB3~0 defined

**Bit 6 (SCAN):** Automatic key scan or specify the scan signal bit by bit.

“0” : Key scan is specified by the defined bits STB3~0.

“1” : Auto strobe scanning

**Code Example:**

```
; Key matrix 1 (Port A and Ground):  
; === Sleep mode  
PAIN_SR:  
    :  
; --- Port A wakeup  
    MOV    A,#11111111B  
    MOV    PAWAKE,A  
; --- /R1EN &/R2EN Pull-up & KE enable  
    MOV    A,#00000001B  
    MOV    PACON,A  
; --- Port A interrupt enable  
    MOV    A,#11111111B  
    MOV    PAINTEN,A  
    CLR    PAINTSTA  
    BS     CPUCON,GLINT  
; --- Sleep MODE  
    BC     CPUCON,MS1  
PAINloop:  
    BS     STBCON,BitST  
    SLEP  
    NOP  
    :  
    SJMP  PAINloop  
; *** Interrupt Port A data  
INPTINT:  
    PUSH  
    MOVRP  PORTH,PAINTSTA  
    BC     STBCON,BitST  
    CLR    PAINTSTA  
    POP  
    RETI
```

```

; Key matrix 2 (Port A and SEG0 ~ SEG15):
; *** Key scan function
:
LCD display setting
:
MOV  A,#0XFF
MOV  PAWAKE,A          ; Port A setting wake-up function
:
; === Key strobe all routine
KeyAll:
CLR  PACON             ; /R1EN, /R2EN enable
BS   STBCON,ALL       ; Strobe all
LCALL DLY10US
BS   PACON,R1EN       ; /R1EN disable
BS   PACON,KE         ; Key enable
LCALL DLY10US
MOV  A,PORTA          ; Port A input data
BC   STBCON,ALL       ; Strobe all disable
BS   PACON,R2EN       ; /R2EN disable
BC   PACON,KE         ; Key disable
JE   A,#0XFE,KeyScan
;
; === Idle mode auto key scan routine
BS   STBCON,SCAN      ; Auto-key scan enable
BS   CPUCON,MS1       ; Idle mode
KeyIdle:
SLEP
NOP
MOV  A,PORTA          ; Port A input data
JE   A,#0XFF,KeyIdle
;
; === Key scan routine
CLR  STBCON           ; Auto-key scan disable
KeyLoop:
CLR  PACON             ; /R1EN, /R2EN enable
BS   STBCON,BitST     ; Strobe ON
LCALL DLY10US
BS   PACON,R1EN       ; /R1EN disable
BS   PACON,KE         ; Key enable
LCALL DLY10US
MOV  A,PORTA          ; Port A input data
BC   STBCON,BitST     ; Strobe OFF
BS   PACON,R2EN       ; /R2EN disable
BC   PACON,KE         ; Key disable
JLE  A,#0FEH,KeyScan  ; If A >= PORTA Goto KeyScan
INC  STBCON
LCALL DLY400US
SJMP KeyLoop
KeyScan:
; --- Check key number
CLR  Key_No
ChKeyNo:
RRC  ACC
JBC  STATUS,F_C,KeyScanOk
INC  Key_No
SJMP ChKeyNo
; --- Key Scan is finish
KeyScanOk:
SWAPA STBCON
AND  A,#11110000B
OR   Key_No,A
SAWP Key_No          ; Key_No:0XXX XXXX
:

```

## 8.9 LCD Driver

The **EPD3332** provides directly driven LCD. It supports multiplexed drive for 64SEG×32COM or up to 96 segments provided with external COM driver, and it is able to use pads as an LCD driver pin or as input/output port. The duty ratio is selected by the LCDCONC register. There is an LCD RAM for direct correspondence with LCD Pixel. Charge pump can pump 2 or 3 times of  $V_x$ . The LCD contrast has 32 levels adjustable. And the LCD bias is selectable. The maximum LCD operating voltage can be determined by external resistor  $R_a$  and  $R_b$ . Furthermore, multiple frame frequencies are provided to reduce power consumption.

This embedded LCD driver contains power supply circuits and generates waveforms to drive the display. Unused common drivers will be defined as general I/O pins.

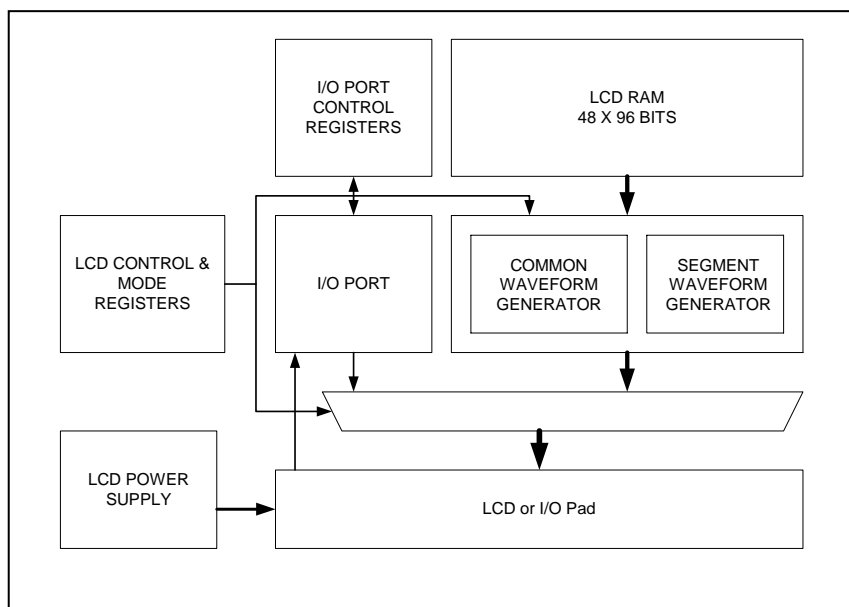

Fig. 8-21 Function Block Diagram

The internal power supply circuits generate the voltage levels to drive liquid crystal driver circuits with low-power consumption and the least components. There are voltage converter (V/C) circuits, voltage regulator (V/R) circuits, and voltage follower (V/F) circuits.

The internal power supply circuits are shown in the following figure.

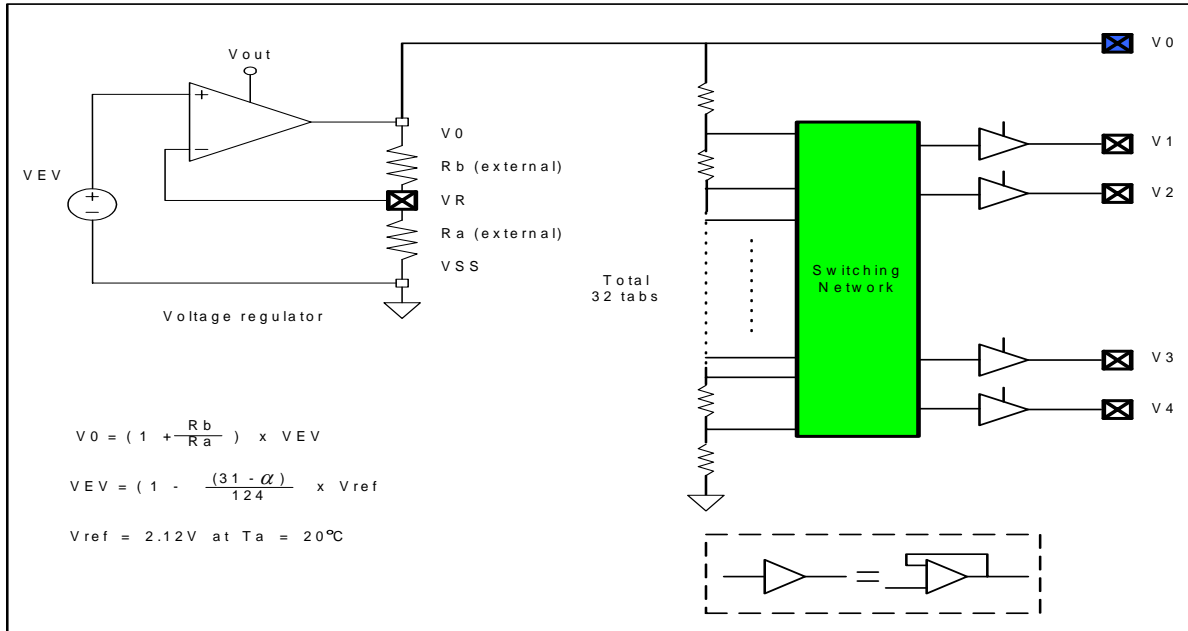

Fig. 8-22 Internal Power Supply Circuitry

\* Switching Network:

LCD Bias	V1	V2	V3	V4
1/3	0.665*V0	0.335*V0	0.665*V0	0.335*V0
1/3.5	0.715*V0	0.430*V0	0.570*V0	0.285*V0
1/4	0.750*V0	0.500*V0	0.500*V0	0.250*V0
1/4.5	0.780*V0	0.555*V0	0.445*V0	0.220*V0
1/5	0.800*V0	0.600*V0	0.400*V0	0.200*V0
1/5.5	0.820*V0	0.635*V0	0.365*V0	0.180*V0
1/6	0.835*V0	0.665*V0	0.335*V0	0.165*V0
1/6.5	0.845*V0	0.690*V0	0.310*V0	0.155*V0

With built-in voltage converter (boost circuit), it generates twice or triple boosted voltage output to VOUT pin. And VOUT provides the operating voltage of the operational-amplifier circuits. The external capacitors must be connected as follows.

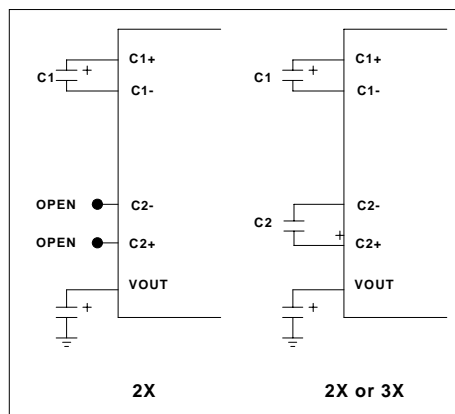

Fig. 8-23 External Capacitors



### 8.9.1 LCD Code Option

- Duty Ratio: Maximum Duty Ratio Option

COM8-15/SEG103-96; COM16-23/SEG87-80 & COM24-31/SEG95-88 Status Setting

Duty Ratio	Max. Display size	Common Driver Used				
		COM0~7/ SEG104~111		COM8~15/ SEG103~96	COM16~23/ SEG87~80	COM24~31/ SEG95~88
1/4	88x4	COM 0~3	Unused	SEG103~96	SEG87~80	SEG95~88
1/8	88x8	COM 0~7		SEG103~96	SEG87~80	SEG95~88
1/9	80x9	COM 0~8		Prohibited	SEG87~80	SEG95~88
1/11	80x11	COM 0~10		Prohibited	SEG87~80	SEG95~88
1/16	80x16	COM 0~15			SEG87~80	SEG95~88
1/24	72x24	COM 0~23				SEG95~88
1/32	64x32	COM 0~31				
1/48	128x48	SEG 64~95 *				

\* The COM pins are supplied as SEG and combined with EM65168A 32 SEG pins, the total is 128 SEG.

- V1; V2; V3 & V4 OP Buffer:

	Small Current	Normal Current	Large Current	No Current
V1	Source	*	Class A/B	OFF
V2	Sink	*	Class A/B	OFF
V3	Source	*	Class A/B	OFF
V4	Sink	*	Class A/B	OFF

\* When in normal display: V1 = source, V2 = sink, V3 = source, V4 = sink

When in auto key scan: During every 30μs strobe start, the OP Amp. changes to class A/B for 60μs, then return to normal display.

- V0 OP buffer control bit: Select "V0 OP buffer turn off" or "V0 OP buffer turn on".
- CLS: LCD master / slave mode select bit
- FRS: FR clock source select bit in LCD slave mode
- LCDLAH: LCD data latch edge select bit

CLS	FRS	LCDLAH	CL pin	FR pin	Data latch	Remark
0	×	0	Output	Output	At CL falling edge	LCD master mode
	×	1	Output	Output	At CL rising edge	LCD master mode
1	0	0	Input	Not connected	At CL falling edge	LCD slave mode
	0	1	Input	Not connected	At CL rising edge	LCD slave mode
	1	0	Input	Input	At CL falling edge	LCD slave mode
	1	1	Input	Input	At CL rising edge	LCD slave mode

- Port G low nibble control bits (SEG48~51): Select “LCD segment signal output” or “General I/O function”
- Port G high nibble control bits (SEG52~55): Select “LCD segment signal output” or “General I/O function”
- Port H low nibble control bits (SEG56~59): Select “LCD segment signal output” or “general I/O function”
- Port H high nibble control bits (SEG60~63): Select “LCD segment signal output” or “general I/O function”

The LCD segment pin configuration is as follows:

SEG0 ~ 15	SEG16 ~ 47	SEG48 ~ 63	SEG64 ~ 79	SEG80 ~ 95	SEG96 ~ 111
SEG0/Key Strobe0   SEG7/Key Strobe7	SEG16   SEG31	SEG48/Port G.0   SEG55/Port G.7	Prohibited	SEG80/COM16   SEG87/COM23	SEG96/COM15   SEG103/COM8
SEG8/Key Strobe8   SEG15/Key Strobe15	SEG32   SEG39	SEG56/Port H.0   SEG63/Port H.7		SEG88/COM24   SEG95/COM31	SEG80/COM7   SEG111/COM0
	SEG40   SEG47				

■ **LCDCONA (R50h): LCD Control Register A**

Bit 7	Bit 6	Bit 5	Bit 4	Bit 3	Bit 2	Bit 1	Bit 0
BSEL2	BSEL1	BSEL0	ADJ4	ADJ3	ADJ2	ADJ1	ADJ0

**Bit 4 ~ Bit 0 (ADJ4 ~ ADJ0): LCD Contrast Adjustment**

ADJ4	ADJ3	ADJ2	ADJ1	ADJ0	$\alpha$	Contrast
0	0	0	0	0	0	Low
0	0	0	0	1	1	
:	:	:	:	:	:	
:	:	:	:	:	:	
1	1	1	1	0	30	
1	1	1	1	1	31	High

$$V_0 = \left(1 + \frac{R_b}{R_a}\right) \times V_{EV} \quad \left(\frac{R_b}{R_a} \text{ is external resistor ratio}\right)$$

$$V_{EV} = \left(1 - \frac{(31 - \alpha)}{124}\right) \times V_{ref} \quad (V_{ref} = 2.12V \text{ at } 20^\circ C)$$

**Bit 7 ~ Bit 5 (BSEL2 ~ BSEL0): LCD Bias select**

BSEL2	BSEL1	BSEL0	LCD Bias
0	0	0	1/3
0	0	1	1/3.5
0	1	0	1/4
0	1	1	1/4.5
1	0	0	1/5
1	0	1	1/5.5
1	1	0	1/6
1	1	1	1/6.5

Different duty ratio requires different bias level. For optimum bias level,  $B_L$  can be calculated from the equation:

$$B_L = \frac{1}{\sqrt{\text{Duty ratio} + 1}}$$

Setting to the optimum bias level will have a better consequence on the contrast and view angle.

■ **LCDCONB (R51h): LCD Control Register B**

Bit 7	Bit 6	Bit 5	Bit 4	Bit 3	Bit 2	Bit 1	Bit 0
REV	-	LCDON	LCDPM2	LCDPM1	LCDPM0	SFR1	SFR0

**Bit 1 ~ Bit 0 (SFR1 ~ SFR0): Frame Frequency Adjustment**

CL Frequency vs. Duty Ratio Table:

		CL Frequency						
SFR1	SFR0	1/4 duty	1/8 duty	1/9 duty	1/11 duty	1/16 duty	1/24 duty	1/32 duty
0	0	$F_{osc} / 104$	$F_{osc} / 52$	$F_{osc} / 46$	$F_{osc} / 38$	$F_{osc} / 26$	$F_{osc} / 17$	$F_{osc} / 13$
0	1	$F_{osc} / 112$	$F_{osc} / 56$	$F_{osc} / 50$	$F_{osc} / 40$	$F_{osc} / 28$	$F_{osc} / 19$	$F_{osc} / 14$
1	0	$F_{osc} / 120$	$F_{osc} / 60$	$F_{osc} / 54$	$F_{osc} / 44$	$F_{osc} / 30$	$F_{osc} / 20$	$F_{osc} / 15$
1	1	$F_{osc} / 128$	$F_{osc} / 64$	$F_{osc} / 56$	$F_{osc} / 46$	$F_{osc} / 32$	$F_{osc} / 21$	$F_{osc} / 16$

**NOTE**

$F_{osc} = 32.8\text{kHz} \pm 25\%$  (all conditions):

The display clock CL affects the current consumption and the frame frequency affects the flicker, so fine adjustments are required for the display clock CL and the frame frequency.

**Bit 4 ~ Bit 2 (LCDPM2 ~ LCDPM0): LCD Power Control Mode**

LCDPM [2:0]	Power Control Mode	V/C Circuits	V/R Circuits	V/F Circuits (V0~V4)	VOUT	Discharge
000	LCD power off mode	Off	Off	Off	Connect to VDD	Off
001	External power mode	Off	Off	Off (From external)	Off (From external)	Off
010	Discharge mode	Off	Off	Off	Do not connect to VDD	On
100	Partial display mode (Vout=VDD)	Off	On	On	Connect to VDD	Off
101	Normal display mode	On	On	On	2x or 3x VDD	Off
Others	Reserved					

**Bit 5 (LCDON):** LCD display control bit. (All COM & SEG pins are tied to ground when LCD display is off)

- “0” : LCD display off
- “1” : LCD display on

**Bit 7 (REV):** LCD panel display status control. The REV is used to invert the display status on the LCD panel without rewriting the contents of the display data RAM.

- “0” : Normal: Display data “1” turns on the LCD
- “1” : Inverse: Display data “0” turns on the LCD

■ **LCDCONC (R52h): LCD Control Register C**

Bit 7	Bit 6	Bit 5	Bit 4	Bit 3	Bit 2	Bit 1	Bit 0
-	DRSEL2	DRSEL1	DRSEL0	BOOST	LCDARH2	LCDARH1	LCDARH0

**Bit 2 ~ Bit 0 (LCDARH2 ~ LCDARH0):** Page address for the LCD RAM

**Bit 3 (BOOST):** Set the number of boosting steps

- “0” : 2 times
- “1” : 3 times

When the BOOST is set to “1”, the clamping circuit will be enabled to clamp the Vx at 2.4V.

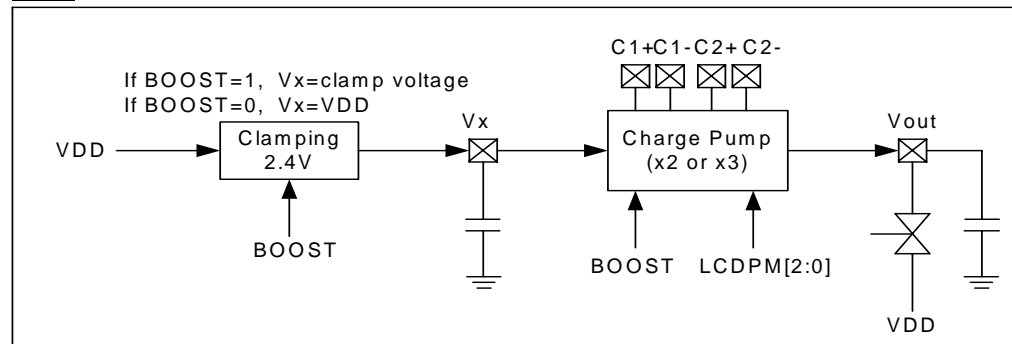

*Fig. 8-24 Clamping Circuitry*

**Bit 6 ~ Bit 4 (DRSEL2 ~ DRSEL0):** LCD duty select. There are eight LCD duty ratio options, and which user can change in different conditions. Operating in normal or partial display mode can reduce power consumption.

DRSEL2	DRSEL1	DRSEL0	Duty Ratio	Max. Display Size
0	0	0	1/4	88×4
0	0	1	1/8	88×8
0	1	0	1/9	80×9
0	1	1	1/11	80×11
1	0	0	1/16	80×16
1	0	1	1/24	72×24
1	1	0	1/32	64×32
1	1	1	1/48	128×48*

\* The COM pins are supplied as SEG and combined with EM65168A 32 SEG pins, the total is 128 SEG.

An external common driver is needed when setting DRSEL2:0=1,1,1, (1/48 duty ratio)

- **LCDARL (R53h):** LCD RAM Column Address
- **LCDDATA (R54h):** LCDDATA register is an indirect addressing pointer of the LCD RAM. Any instruction using LCDDATA as register actually accesses the LCD RAM pointed to by LCDARH: LCDARL.



- **POST\_ID (R2Bh):** Post increase/decrease the control register. After accessing (read or write) the LCD RAM, the **LCDARL** register can be automatically increased or decreased by setting the POST\_ID register.

Bit 7	Bit 6	Bit 5	Bit 4	Bit 3	Bit 2	Bit 1	Bit 0
-	LCD_ID	FSR1_ID	FSR0_ID	-	LCDPE	FSR1PE	FSR0PE

**Bit 2 (LCDPE):** Enable LCDARL post increase/decrease function.

**Bit 6 (LCD\_ID):** Set to 1 means auto-increase, reset to 0 means auto-decrease the LCDARL register.

**LCD RAM MAP (Note: LCDARL=40h~4Fh is Not for Use)**

**PAGE 00 (LCDARH[2:0]=000)**

RAM Address		COM0	COM1	COM2	COM3	COM4	COM5	COM6	COM7
LCDARL		Bit 0	Bit 1	Bit 2	Bit 3	Bit 4	Bit 5	Bit 6	Bit 7
SEG0	00H								
:	:								
SEG63	3FH								
<b>40h~4Fh</b>		<b>Not for Use</b>							
SEG80	50H								
:	:								
SEG111	6FH								

**PAGE 01 (LCDARH[2:0]=001)**

RAM Address		COM8	COM9	COM10	COM11	COM12	COM13	COM14	COM15
LCDARL		Bit 0	Bit 1	Bit 2	Bit 3	Bit 4	Bit 5	Bit 6	Bit 7
SEG0	00H								
:	:								
SEG63	3FH								
<b>40h~4Fh</b>		<b>Not for Use</b>							
SEG80	50H								
:	:								
SEG111	6FH								

**PAGE 02 (LCDARH[2:0]=010)**

RAM Address		COM16	COM17	COM18	COM19	COM20	COM21	COM22	COM23
LCDARL		Bit 0	Bit 1	Bit 2	Bit 3	Bit 4	Bit 5	Bit 6	Bit 7
SEG0	00H								
:	:								
SEG63	3FH								
<b>40h~4Fh</b>		<b>Not for Use</b>							
SEG80	50H								
:	:								
SEG111	6FH								

**PAGE 03 (LCDARH[2:0]=011)**

RAM Address		COM24	COM25	COM26	COM27	COM28	COM29	COM30	COM31
LCDARL		Bit 0	Bit 1	Bit 2	Bit 3	Bit 4	Bit 5	Bit 6	Bit 7
SEG0	00H								
:	:								
SEG63	3FH								
<b>40h~4Fh</b>		<b>Not for Use</b>							
SEG80	50H								
:	:								
SEG111	6FH								



PAGE 04 (LCDARH[2:0]=100)

RAM Address LCDARL		COM32	COM33	COM34	COM35	COM36	COM37	COM38	COM39
		Bit 0	Bit 1	Bit 2	Bit 3	Bit 4	Bit 5	Bit 6	Bit 7
SEG0	00H								
:	:								
SEG63	3FH								
<b>40h~4Fh</b>		<b>Not for Use</b>							
SEG80	50H								
:	:								
SEG111	6FH								

PAGE 05 (LCDARH[2:0]=101)

RAM Address LCDARL		COM40	COM41	COM42	COM43	COM44	COM45	COM46	COM47
		Bit 0	Bit 1	Bit 2	Bit 3	Bit 4	Bit 5	Bit 6	Bit 7
SEG0	00H								
:	:								
SEG63	3FH								
<b>40h~4Fh</b>		<b>Not for Use</b>							
SEG80	50H								
:	:								
SEG111	6FH								

LCD Waveform:

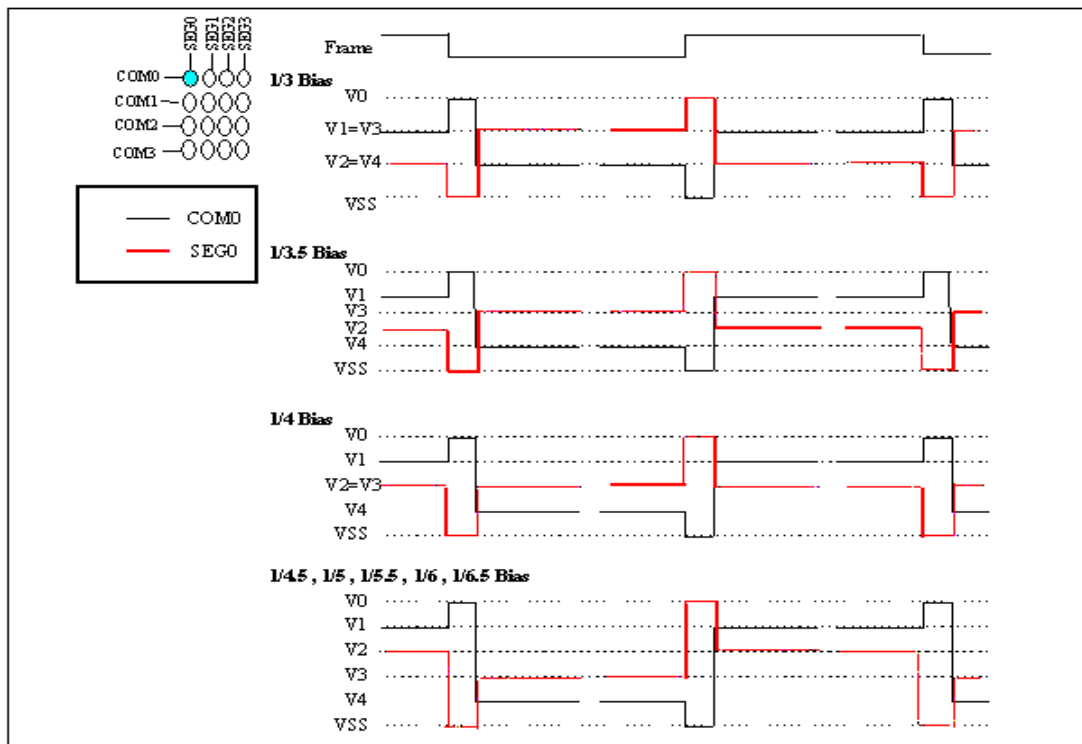

**Code Example:**

```

; === 1/32 Duty & 1/6.5 Bias
L32Duty:
; --- /6.5 Bias
    MOV     A,#11110000B
    MOV     LCDCONA,A
; --- 1/32 Duty, BOOST=1
    MOV     A,#01101000B
    MOV     LCDCONC,A
; --- LCD Off, Normal Display Mode
    MOV     A,#00010111B
    MOV     LCDCONB,A
    SCALL   DspRAMdot
; --- LCD turn-on
    BS      LCDCONB,LCDON
    LCALL   Delay1sec
    :
DspLoop:
; --- Partial display mode
    BC      LCDCONB,LCDPM0
    LCALL   Delay1sec
; --- Inverse display
    BS      LCDCONB,LCDPM0
    BS      LCDCONB,REV
    LCALL   Delay1sec
; --- Normal display
    BC      LCDCOMB,REV
    LCALL   Delay1sec
    :
    SJMP   DspLoop

; *** Display LCD RAM is data 55 & AA
DspRAMdot:
; --- LCD increase enable
    MOV     A,#01000100B
    MOV     POST_ID,A
; --- CD page 00
    MOV     A,#11111000B
    AND     LCDCONC,A
DspRAMd1:
    CLR     LCDARL
    MOV     A,#0X20
    MOV     CNT_HI,A
    SCALL   WrLRAMd
    MOV     A,#050H
    MOV     LCDARL,A
    MOV     A,#0X10
    MOV     CNT_HI,A
    SCALL   WrLRAMd
    INC     LCDCONC
    MOV     A,#00000111B
    AND     A,LCDCONC
    JLE     A,#00000110B,DspRAMd1
    RET
; === Write LCD RAM is dot matrix
WrLRAMd:
    MOV     A,#0X55
    MOV     LCDDATA,A
    MOV     A,#0XAA
    MOV     LCDDATA,A
    JDNZ   CNT_HI,WrLRAMd
    RET

```

## 8.10 Serial Peripheral Interface (SPI)

- Operation in either Master mode or Slave mode
- Three-wire or Four-wire full duplex synchronous communication
- Programmable Shift Register Length (24/16/8 bits)
- Programmable communication bit rates
- Programmable clock polarity
- Programmable shift direction
- Programmable sample phase
- Interrupt flag available for the read buffer full
- Up to 2.5MHz (system clock at 10MHz) bit frequency

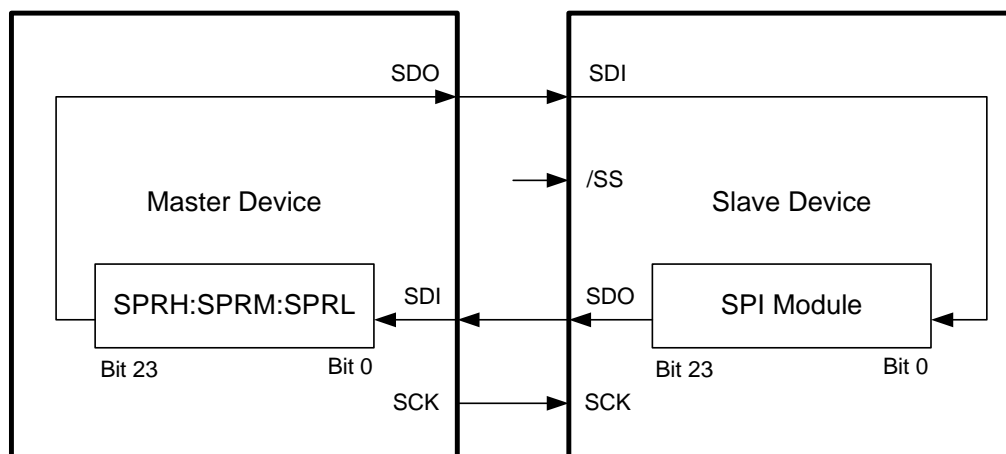

Fig. 8-25a Single SPI Master/Slave Communication

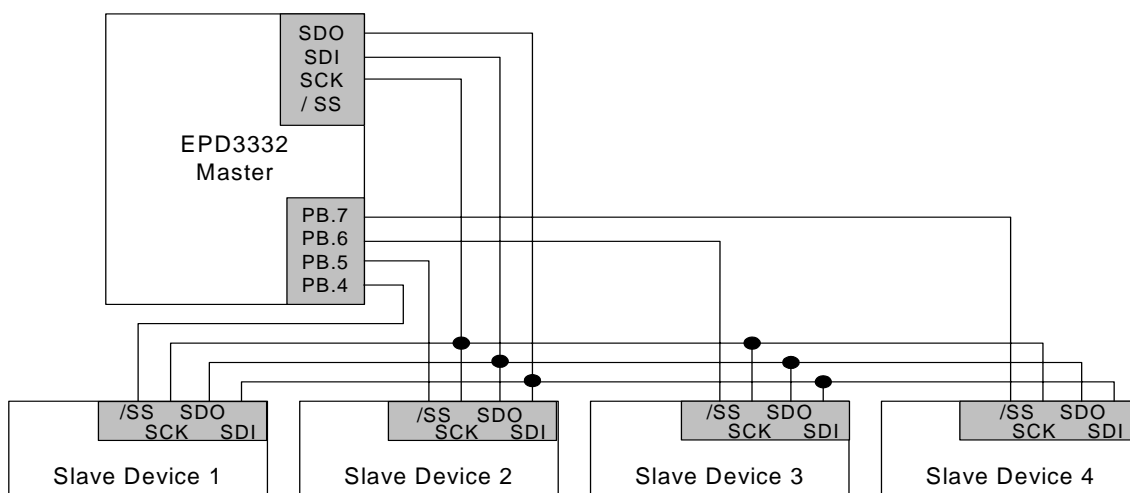

Fig. 8-25b SPI Configuration Example of Single-Master and Multi-Slaves

The MCU communicates with other devices through an SPI module. If the MCU is defined as the master controller, it sends clock through the SCK pin. An 8-bit data is transmitted and received at the same time. If the MCU, however, is defined as a slave, its SCK pin could be programmed as an input pin. Data will continue to be shifted at selected clock rate and selected edge.

Setting up the **TLS1 ~ TLS0** bits of the SPICON register can select the shift register length of the SPI and enable/disable the SPI function. Setting up the **BRS2 ~ BRS0** bits of the SPICON register can select the SPI mode (master/slave) and Bit Rate. When in master mode, the clock source can be selected from the system clock or half of Timer 0 interval. When in slave mode, the **/SS** pin can be enabled or disabled. Setting up the **DORD** bit of the SPICON register can determine the shift direction. Setting up the **EDS** bit of the SPICON register can select either rising edge or falling edge to latch the data.

Setting up the **SMP** bit of the SPISTA register can select the sample phase whether at the middle or at the end of data output time.

#### ✧ **Master Mode**

In master mode, SCK pin is as a clock output pin.

If 24 bits shift register length is selected, SPRH, SPRM and SPRL registers are the high, middle and low bytes of the shift register. (If 8 bits shift register length is selected, SPRL register is the content of the shift register). Data are written to SPRH, SPRM and SPRL registers, after writing data into the SPRL register, the **SE** bit of the SPICON register will automatically be set by hardware and starts shifting. After a shift buffer is empty, the **SE** bit will be cleared by hardware and stops clock output from the **SCK** pin.

The receiver is active during SPI transfer. When the receiving buffer is full, the **RBF** flag will be set and an interrupt occurs (if enabled). During a read out of the shift register contents, and after the SPRL register has been read out, the hardware will automatically clear the **RBF** flag. If SPRL register has not been read out, **RBF** bit still remains set. Data collision will occur during the next clock input.

#### ✧ **Slave Mode**

In slave mode, the input clock is from the MASTER device. **SCK** pin is a clock input pin. The **SE** bit is not used to control the starting shift in this mode. But it is a Transfer buffer empty status bit.

The same as with the MASTER MODE, user can select the shift register length. Transfer data are written to SPRH, SPRM, SPRL registers. After writing data into the SPRL register, the **SE** bit of SPICON register will be set by hardware. But the shifting start is controlled by the MASTER device clock input.



While the shift buffer is empty the **SE** bit will be cleared. At the same time, when the receive buffer is full, the **RBF** flag will be set and an interrupt occurs (if enabled). The received data is at SPRH, SPRM and SPRL register; user should read them out before the next clock input. Otherwise, data collision will occur and the **DCOL** bit of the SPISTA register will be set.

### 8.10.1 SPI Pin Description

- SDI (I):** Serial Data Input pin. Receives data serially
- SDO (O):** Serial Data Output pin. Transmits data serially. In Slave mode, defined as high-impedance, if not selected.
- SCK (I/O):** Serial Clock input/output pin. When in Master mode, sends clock through the SCK pin. However, in Slave mode, SCK pin is programmed as an input pin).
- /SS (I):** /Slave Select pin. This pin becomes active when /SS function is enabled. (BRS=110), else /SS pin is a general purpose I/O.  
Master device remains low for /SS pin to signify the slave(s) for transmit/receive data. Ignore the data on the SDI and SDO pins when /SS pin is high, since the SDO is no longer driven.

### 8.10.2 SPI Applicable Registers

- **SPRH; SPRM; SPRL (R41h; R42h; R43h):** SPI shift buffer for 24/16/8 bits length.

The buffer will ignore any write until shifting is completed. If user selects 24 bits shift buffer, it will include the SPRH: SPRM: SPRL. However, if 8 bits shift buffer is selected, only the SPRL register is included.

When writing data into the SPRL register, the **SE** bit of the SPICON register will be set by hardware and shifting starts. When the shift buffer is empty, and the receive buffer is full at the same time, the received data is shifted into SPRH, SPRM and SPRL registers. After the SPRL register has been read out, the hardware will automatically clear the **RBF** flag.

- **SPICON (R3Fh):** SPI Control Register

Bit 7	Bit 6	Bit 5	Bit 4	Bit 3	Bit 2	Bit 1	Bit 0
TLS1	TLS0	BRS2	BRS1	BRS0	EDS	DORD	SE

- Bit 0 (SE):** Shift enable. Set to “1” automatically when writing data into the SPRL register and shifting starts. Reset to “0” when a transfer buffer empty is detected.

**NOTE**

*The SE bit is read-only and is cleared by hardware when SPI is enabled. Hence, writing to the SPRL register is necessary when user wants to start shifting the data.*

**Bit 1 (DORD):** Data transmission order

“0” : Shift left (MSB first)

“1” : Shift right (LSB first)

**Bit 2 (EDS):** Select the rising / falling edge latch by programming the EDS bit

“0” : Falling edge

“1” : Rising edge

**Bit 5 ~ Bit 3 (BRS2 ~ BRS0):** Bit rate select. Programming the clock frequency/rates and sources.

000 : Master, TMR0/2

001 : Master, Fsystem/4

010 : Master, Fsystem/16

011 : Master, Fsystem/64

100 : Master, Fsystem/256

101 : Master, Fsystem/1024

110 : Slave, /SS enable

111 : Slave, /SS disable

SPI Bit Rate Table

Prescaler		Fsystem		
BRS2:0	Bit Rate	10MHz	4MHz	32.768kHz
001	Fsystem/4	2500000	1000000	8196
010	Fsystem/16	625000	250000	2048
011	Fsystem/64	156250	62500	512
100	Fsystem/256	39063	15625	128
101	Fsystem/1024	9766	3096	32

**Bit 7 ~ Bit 6 (TLS1 ~ TLS0):** Shift buffer length select. The Shift buffer length is programmable.

00: SPI disable

01: Enable SPI and shift buffer length = 24 bits

10: Enable SPI and shift buffer length = 16 bits

11: Enable SPI and shift buffer length = 8 bits

■ **SPISTA (R40h):** SPI Status Register

Bit 7	Bit 6	Bit 5	Bit 4	Bit 3	Bit 2	Bit 1	Bit 0
WEN	-	SRBFIE	SRBFI	SPWKEN	SMP	DCOL	RBF

**Bit 0 (RBF):** Set to “1” by Buffer Full Detector, and automatically cleared to “0” when data are read from the SPRL register.

**NOTE**

*The RBF bit is cleared by hardware when SPI is enabled and this bit becomes read-only. Hence, reading the SPRL register is necessary to avoid data collision (DCOL) condition.*



- Bit 1 (DCOL):** SPI Data collision
- Bit 2 (SMP):** SPI data input sample phase  
 “0” : Input data sampled at the middle of data output time  
 “1” : Input data sampled at the end of data output time

**NOTE**  
*In Slave mode, data input sample is fixed at the middle of data output time.*

- Bit 3 (SPWKEN):** SPI wake up enable control bit  
 “0” : Disable SPI (Slave mode) read buffer full wakeup  
 “1” : Enable SPI (Slave mode) read buffer full wakeup
- Bit 4 (SRBFI):** Set to “1” when an SPI read buffer full occurs. Cleared to “0” by software or disable SPI.  
 “0” : Data collision does not occur  
 “1” : Data collision occurs. Should be cleared by software
- Bit 5 (SRBFIE):** Control bit of SPI read buffer full interrupt  
 “0” : Disable interrupt function  
 “1” : Enable interrupt function

■ **CPUCON (R0Eh):** MCU Control Register

Bit 7	Bit 6	Bit 5	Bit 4	Bit 3	Bit 2	Bit 1	Bit 0
PEN	-	-	SMCAND	SMIER	GLINT	MS1	MS0

- Bit 2 (GLINT):** Global interrupt control bit  
 “0” : Disable all interrupts  
 “1” : Enable all un-mask interrupts

### 8.10.3 SPI Timing Diagrams

■ Master Mode (Shift Buffer Length = 24Bits)

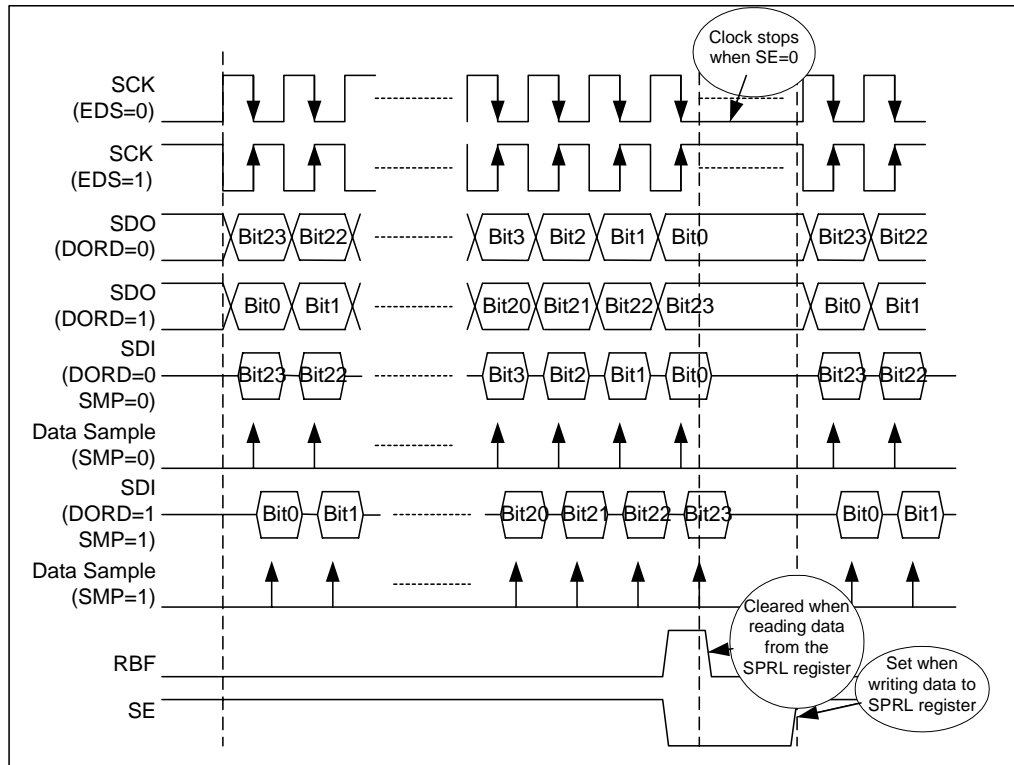

Fig. 8-26 SPI Master Mode Timing Diagram

**Code Example: Master Mode (8bit)**

```

;*** Interrupt SPI
PERIPH:
    PUSH
    COMA    DATACNT
;--- SPI read buffer full
    JBC     SPISTA,SRBFI,Q_SPINT
    BC     SPISTA,SRBFI
    BS     INTFLAG,F_SPI
;--- SPI Data collision
    JBC     SPISTA,DCOL,Q_SPINT
    MOV    A,#0XFF
Q_SPINT:
    MOV    DATACNT,A
    POP
    RETI
;=== 8MHz/4 = 2000000 bit rate
SPIM_SR:
    :
    System setting 8MHz
    Port G setting output port
    :
;--- 8bit, Fsystem/2, Rising edge & MSB
    MOV    A,#11001100B
    MOV    SPICON,A
;--- SPI full interrupt
    MOV    A,#00100000B
    MOV    SPISTA,A
;--- Global interrupt
    BS     CPUCON,GLINT
;--- SPI data output => 55
    MOV    A,#0X55
    MOV    DATACNT,A
SPI8LOOP:
    MOV    A,DATACNT
    MOV    SPRL,A
;--- SPI Data collision
    JBC     SPISTA,DCOL,SPI8LP1
    BC     SPISTA,DCOL
;--- SPI data output resend => 55
    MOV    A,#0X55
    MOV    DATACNT,A
SPI8LP1:
    JBC     INTFLAG,F_SPI,SPI8LP1
SPI8LP2:
    BC     INTFLAG,F_SPI
    MOVRP  PORTG,SPRL
    SJMP   SPI8LOOP

```

■ **Slave Mode (Shift Buffer Length = 8Bits, /SS Enabled)**

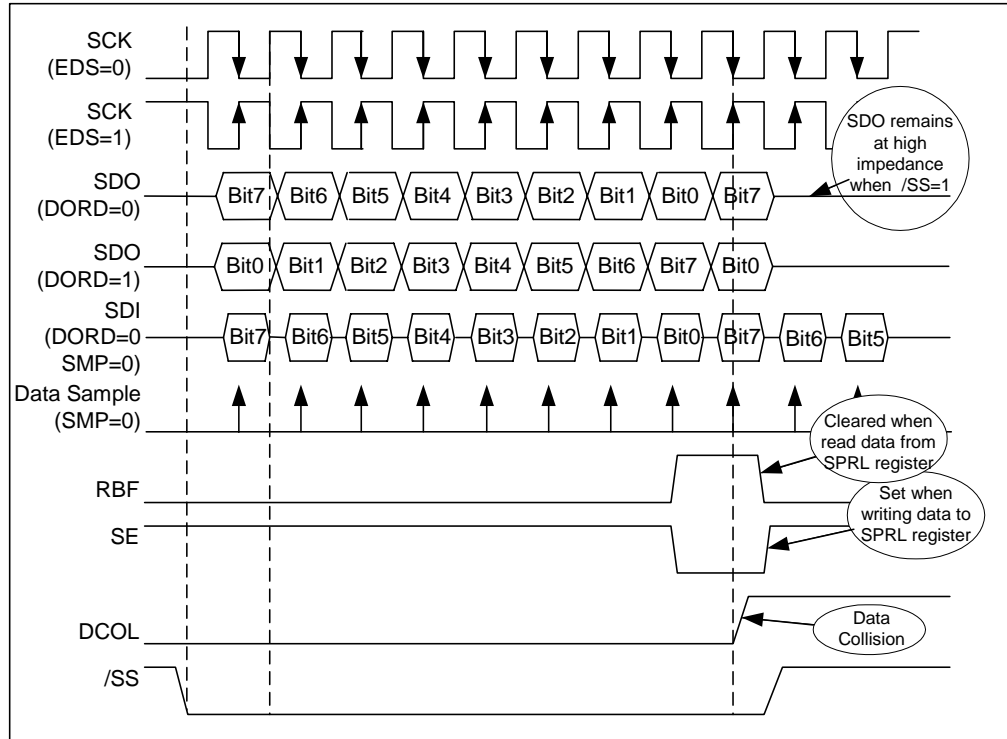

Fig. 8-27 SPI Slave Mode Timing Diagram

**Code Example: Slave Mode (8bit)**

```

; *** Interrupt SPI
PERIPH:
    PUSH
    JBC    SPISTA,SRBFI,Q_SPINT
    BC    SPISTA,SRBFI
    BS    INTFLAG,F_SPI
Q_SPINT:
    POP
    RETI
; *** SPI slave mode
:
    System setting 8MHz
    Port G setting output port
:
; === SPI 8bit & Sleep mode
SPIS_SR:
; --- 8bit, Slave /SS enable, Rising edge & LSB
    MOV    A,#11110100B
    MOV    SPICON,A
; --- SPI Wakeup & SPI full interrupt
    MOV    A,#00101000B
    MOV    SPISTA,A
; --- Global interrupt
    BS    CPUCON,GLINT
; --- Sleep mode
    BC    CPUCON,MS1
SPIS8Lp:
    SLEP
    NOP
    MOV    PORTG,SPRL
    BC    INTFLAG,F_SPI
; --- SPI Data collision
    JBC    SPISTA,DCOL,SPIS8Lp
    MOV    A,#0XFF
    MOV    SPRL,A
    SJMP   SPIS8Lp
    
```

## 8.11 Melody/Speech Synthesizer

The EPD3332 MCU provides four channels for melody/speech function. Channels 1~3 are destined for melody channel, and Channel 4 can be either a melody or a speech channel as determined by SPHSB bit (Bit 2 of R44). Channels 1 ~ 4 are controlled by R45 ~ R4A of the corresponding control register Banks 0 ~ 3. Bits 0 ~ 2 of R44 are used to select the current control register bank.

	Melody Channel 1	Melody Channel 2	Melody Channel 3	Melody Channel 4/ Speech Channel
R44h	xxxx x000	xxxx x001	xxxx x010	xxxx x011 / xxxx x1xx
R45h	ADDL	ADDL	ADDL	ADDL / -
R46h	ADDM	ADDM	ADDM	ADDM / -
R47h	ADDH	ADDH	ADDH	ADDH / -
R48h	ENV	ENV	ENV	ENV / SPHDR
R49h	MTCON	MTCON	MTCON	MTCON / SPHTCON
R4Ah	MTRL	MTRL	MTRL	MTRL / SRHTRL

### ■ SFCR (R44h): Special Function Control Register

Bit 7	Bit 6	Bit 5	Bit 4	Bit 3	Bit 2	Bit 1	Bit 0
AGMD2	AGMD1	AGMD0	WDTPSR1	WDTPSR0	SPHSB	CSB1	CSB0

**Bit 0 ~ 1 (CSB0 ~ CSB1):** Channel select bits

**Bit 2 (SPHSB):** Speech Channel/Melody Channel 4 select bit

“0” : Melody Channel 4 enabled, Speech channel disabled

“1” : Melody Channel 4 disabled, Speech channel enabled

SFCR[2:0]	Channel Selection	Control Register Bank
000	Melody Channel 1	Bank 0
001	Melody Channel 2	Bank 1
010	Melody Channel 3	Bank 2
011	Melody Channel 4	Bank 3
1xx	Speech Channel	Bank 3

### 8.11.1 Melody Function

The MCU melody function can effectively manage the instrument waveform address setting, instrument synthesis frequency control, and envelope control. It is embedded with four melody channels and with built-in large data ROM size for melody waveform data storage. To synthesize the instrument melody, user should write the starting address of the waveform to R45 ~ R47, setup the envelope value, and then enable the melody timer. The control registers are listed as follows:

■ **ADDH, ADDM, ADDL (R47h ~ R45h):** Address Registers (Write-only registers)

These registers, i.e., ADDL, ADDM, and ADDH are treated as instrument waveform address. Each melody channel has its own waveform data address pointer that points to the waveform start address in the data ROM. The address values are written by the program and its total length is 24 bits.

■ **ENV (R48h):** Envelope Register

The envelope register stores the envelope value for the current melody channel. The user's program should calculate the proper envelope value to obtain a suitable ADSR (Attack-Decay-Sustain-Release) for different instruments. The tone generator will process the waveform data with the envelope automatically and then synthesize the final instrument melody to the mixer of the PWM and D/A converter.

The data written to the envelope register should be a 7-bit unsigned value and located in Bits 0~6 (the corresponding envelope value must be 0 to 127), which means the envelope resolution is of 128 steps. The reset initial value is "0."

■ **MTRL (R4Ah):** Melody Timer Auto-reload Register

Bit 7	Bit 6	Bit 5	Bit 4	Bit 3	Bit 2	Bit 1	Bit 0
MTRL7	MTRL6	MTRL5	MTRL4	MTRL3	MTRL2	MTRL1	MTRLO

Melody timer is an 11-bit down counter for melody applications. The frequency generated by the melody timer is determined by the value of 11-bit melody timer auto-reload register (including MTRL and MTRLH0~2 of MTCON). When the counter value underflows, the timer will be auto-reloaded. To obtain the correct frequency, consult a frequency reference table and fetch the correct value for MTRL and MTRLH0~2 of MTCON.

■ **MTCON (R49h):** Melody Timer Control Register

The MTCON is used to determine the three MSB's of the 11-bit auto-reload register and to enable/disable the melody timer of the current melody channel. Once the melody timer is enabled, it will fetch the waveform data (pointed to by the address registers) from the data ROM, process the data with the envelope, and then feed the data to the DAC or PWM mixer automatically. . The reset initial value of the MTCON is "xxxx 0000".

Bit 7	Bit 6	Bit 5	Bit 4	Bit 3	Bit 2	Bit 1	Bit 0
-	-	-	-	MTEN	MTRLH2	MTRLH1	MTRLH0

**Bit 0 ~ 2 (MTRLH0 ~ MTRLH2):** Bit 8 ~10 of the melody timer auto-reload register

**Bit 3 (MTEN):** Melody Timer Enable Control Bit

MTEN	Melody Timer Enable or Disable
0	Melody Timer Disable
1	Melody Timer Enable

### 8.11.2 Speech Function

The 11-bit speech timer is shared with a melody timer (MT4) for Channel 4. The clock source for speech timer is from  $F_{PLL}/2$ . When R44 [2:0] = "1xx," the control register bank will change to speech channel. An interrupt function is available for user's application. The control registers are listed as follows:

$$Sampling\_rate = \frac{F_{PLL} / 2}{SPHTRL[10:0] + 1}$$

■ **SPHDR (R48h):** Speech Data Register

In speech function control, SPHDR acts as an output window to the PWM and D/A converter mixer. The program should write the synthesized data to SPHDR, and the data is fed into the mixer at the next speech timer underflow. For correct mixing operation, the value to be written to SPHDR must be an 8-bit signed data. The reset initial value is "0".

■ **SPHTRL (R4Ah):** Low byte of Speech Timer Auto-reload Register

Speech timer is an 11-bit down counter for speech applications. The frequency generated by speech timer is determined by the value of the 11-bit auto-reload register, including SPHTRL and SPHTRLH0 ~ SPHTRLH2 of SPHTCON. When the counter value underflows, the timer interrupt will occur and auto-reload from the 11-bit auto-reload register.

■ **SPHTCON (R49h):** Speech Timer Control Register

SPHTCON is used to determine the three MSB of the 11-bit auto-reload register and enable/disable the speech timer. The reset initial value of SPHTCON is "xx00 0000".

Bit 7	Bit 6	Bit 5	Bit 4	Bit 3	Bit 2	Bit 1	Bit 0
-	-	SPHTI	SPHTIE	SPHTEN	SPHTRLH2	SPHTRLH1	SPHTRLH0

**Bits 0~2 (SPHTRLH0~ SPHTRLH2):** Bits 8 ~ 10 of the 11-bit auto-reload register

**Bit 3 (SPHTEN):** Speech Timer Enable Control Bits

SPHTEN	Speech Timer Enable or Disable
0	Speech Timer Disabled
1	Speech Timer Enabled

**Bit 4 (SPHTIE):** Speech Timer interrupt control bit  
 “0” : Disable interrupt function  
 “1” : Enable interrupt function

**Bit 5 (SPHTI):** Speech timer interrupt flag. Set to “1” when the speech timers interrupt occurred. Cleared to “0” by software or speech timer is disabled.

■ **CPUCON (R0Eh):** MCU Control Register

Bit 7	Bit 6	Bit 5	Bit 4	Bit 3	Bit 2	Bit 1	Bit 0
PEN	-	-	SMCAND	SMIER	GLINT	MS1	MS0

**Bit 2 (GLINT):** Global interrupt control bit  
 “0” : Disable all interrupts  
 “1” : Enable all un-masked interrupts

## 8.12 PWM / DAC Function

The EPD3332 is embedded with two choices of melody/speech outputs, i.e., PWM and D/A converter.

When the PWM function is enabled, the voice output uses PWM to drive the speaker directly. The 8-bit PWM function block diagram is shown in the following figure. The PWD register is double buffered for glitch free operation.

When Bit 7 of PWD is “1” and the PWM timer counter equals to PWM value (Bits 0 ~ 6 of PWD), the VO1 transfers to low until the PWM timer is reset or overflowed. The VO2 is always kept at “0” in this case.

When the Bit 7 of PWD is “0” and the PWM timer counter equals to the inverse of Bits 0 ~ 6 of PWD, the VO2 transfers to low until the PWM timer is reset or overflowed. The VO1 is always kept at “0” in this case.

$$T_{period} = \frac{128}{F_{PLL}} \times Pr_{escaler}; \quad T_{duty} = \frac{1}{F_{PLL}} \times Pr_{escaler} \times (PWD + 1)$$

### 8.12.1 PWM Function Block Diagram

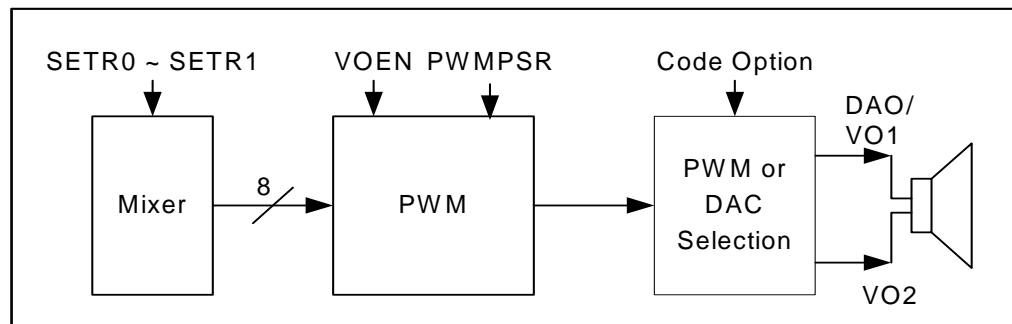

Fig. 8-28 PWM Function Block Diagram

### 8.12.2 DAC Function Block Diagram

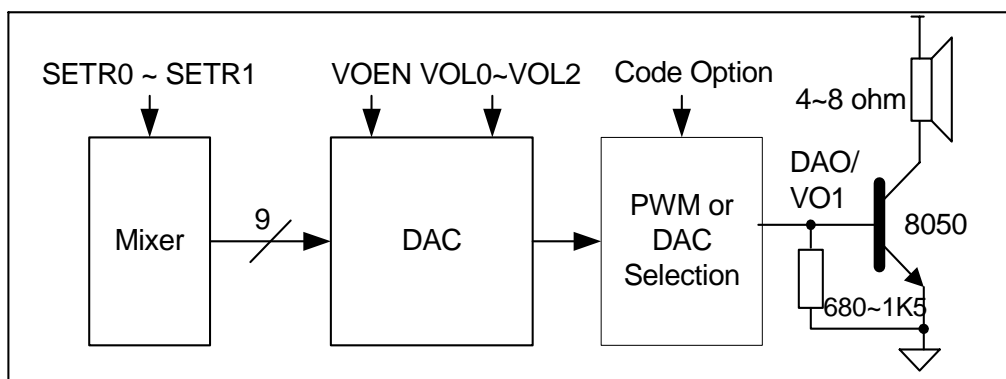

Fig. 8-29 DAC Function Block Diagram

If both SPHSB and VOEN bits are set to “1” and SPHTEN bit is cleared to “0”, the data of the speech data register will be output immediately through the D/A converter or PWM when the register changes.

### 8.12.3 PWM / DAC Function Registers

■ **VOCON (R4Bh):** Voice Output Control Register

Bit 7	Bit 6	Bit 5	Bit 4	Bit 3	Bit 2	Bit 1	Bit 0
VOEN	-	SETR1	SETR0	PWMPSR	VOL2	VOL1	VOL0

**Bit 0 ~ 2 (VOL0 ~ VOL2):** Volume control of DAC

VOL2 ~ VOL0	Volume
000	1 (min.)
001	2
010	3
011	4
100	5
101	6
110	7
111	8 (max.)

**Bit 3 (PWMPSR):** PWM Timer prescaler select bit

- “0” : Prescaler 1:1
- “1” : Prescaler 1:2

**Bits 5 ~ 4 (SETR1 ~ SETR0):** Set dynamic range

While mixing, the mixer accumulation result may have a large dynamic range (up to 11-bit), while DAC has only 9-bit resolution and PWM has only 8-bit. User can define a suitable output data range to prevent the saturation condition from occurring.

SETR1~SETR0	Output data fed to PWM/DAC
10	Take Bits 3~10 of mixer accumulation result for PWM Take Bits 2~10 of mixer accumulation result for DAC
01	Take Bits 2~9 of mixer accumulation result for PWM Take Bits 1~9 of mixer accumulation result for DAC
00 or 11	Take Bits 1~8 of mixer accumulation result for PWM Take Bits 0~8 of mixer accumulation result for DAC

**Bit 7 (VOEN):** Voice output control bit  
 “0” : DAC/PWM disabled  
 “1” : DAC/PWM enabled

Code Example: Refer to Melody & Speech Application Note

## 9 Electrical Characteristic

### 9.1 Absolute Maximum Ratings

Items	Sym.	Condition	Limits	Unit
Supply voltage	VDD		-0.3 to +3.6	V
Input voltage (general input port)	VIN		-0.5 to VDD +0.5	V
Power Dissipation (T <sub>opr</sub> =60°C)	PD		300	mW
Operating temperature range	TOPR		-10 to +60	°C
Storage temperature range	TSTR		-55 to +125	°C

### 9.2 Recommended Operating Conditions

Items	Sym.	Condition	Limits	Unit
Supply voltage	VDD		2.2 to 3.6	V
	AVDD		2.4 to 3.6	
Input voltage	VIH		VDD × 0.9 to VDD	V
	VIL		0 to VDD × 0.1	V
A/D full-Scale input span	ADRG	Positive input-negative input	0 to VREX	V
Operating temperature	TOPR		-10 to +60	°C

### 9.3 DC Electrical Characteristics (Condition: Ta=-10~+60°C, VDD= 3.0 ± 0.3V)

Parameter	Sym.	Condition		Min	Typ	Max	Unit	
CLOCK	Fmain	Main-clock frequency		1	-	10	MHz	
	Fsub	Sub-clock frequency	RC OSC	24.6	32.8	41	kHz	
			Crystal OSC	-	32.768	-		
Supply Current	Idd1	SLEEP mode	VDD = 3V, no load	-	-	1	μA	
	Idd2	IDLE mode	VDD = 3V RC OSC, LCD disable	-	8	12		
	Idd3		VDD = 3V, Crystal OSC, LCD disable	-	5	8		
	Idd4		VDD = 3V, Crystal / RC OSC, LCD enable, auto key scan enable (V0 = 3.8V, 1/3 bias, code option of V1 & V4, OP=*1, V2 & V3 OP off, No load)	-	80	100		
	Idd5		SLOW mode	VDD = 3V, LCD disable, RC/Crystal OSC, No load	-	20		30
	Idd6		FAST mode	VDD = 3V, Fmain = 4MHz, No load	-	1200		1600
	Idd7			VDD = 3V, Fmain = 10MHz, No load	-	2200		2900
Input Voltage	VIH1	PA[0:7], PB[0:2,5:7], PC[2:7], PD[4:7], PG[0:7]		VDD×0.7	-	VDD	V	
	VIL1	PH[0:7] (as general input port)		0	-	VDD×0.3		
Input Threshold Voltage (Schmitt)	VT+	RSTB, PB.5 (as EVIN or CPIN), FR & CL (as input port);		0.5×VDD	-	0.75×VDD	V	
	VT-			0.2×VDD	-	0.4×VDD		
Output Current	IOH1	PB[7:6],PB[5],PB[1:0],PC[2:7],	VDD = 3V, VOH = 2.4V	-1.1	-2.2	-3.3	mA	
	IOL1	PD[7:4] (as general output port), CL & FR (as output pin)	VDD = 3V, VOL = 0.2V	+1.1	+2.2	+3.3		
	IOH2	PB[1] (as D/A output)	VDD = 3.0V, VOH = 0.7V	-2.5	-3.5	-4.5		
	IOH3	PB[1:0] (as PWM output)	VDD = 3.0V, VOH = 1.5V	-200	-300	-400		
	IOL3		VDD = 3.0V, VOL = 1.5V	+200	+300	+400		
	IOH5	PG[7:0]~PH[0:7]	VDD = 3.0V, VOH = 2.4V	-1.1	-2.2	-3.3	mA	
	IOL5		VDD = 3.0V, VOL = 0.2V	+1.1	+2.2	+3.3	mA	
	IOH6	PB[2] (as IR output pin)	VDD = 3.0V, VOH = 2.1V	-5	-10	-15	mA	
IOL6	VDD = 3.0V, VOL = 0.9V		+4	+8	+12	mA		
Input Leakage Current	IIL	ALL Input port (without pull up/down resistor) Vin = VDD or GND		-	-	±1	μA	
Large Pull up resistance	RPU1	PA[6:0]	Key high resistance, pulled up by R2, LCD enable (BOOST = 1, normal display mode), Vin = GND, VDD = 3V	150	300	450	KΩ	
	RPU3	PA[7], PB[0:2,5:7], PC[2:7], PD[4:7]	Vin = GND, VDD = 3V	500	1000	1500		
		PG[7:0]~PH[7:0]	Vin = GND, VDD = 3V	150	300	450		
	RPU5	RSTB	Vin = GND, VDD = 3V	250	500	750		



Parameter	Sym.	Condition		Min	Typ	Max	Unit
Small Pull up Resistance	RPU2	PA[6:0]	Key low resistance, pulled up by R1//R2, LCD enable (BOOST = 0, normal display), Vin = GND, VDD = 3V	40	80	120	KΩ
			Key low resistance, pulled up by R1//R2, LCD enable (BOOST = 1, normal display), Vin = GND, VDD = 3V	55	110	165	
	RPU4	PA[7], PB[0:2,5:7], PC[2:7], PD[4:7]	Vin = 2V, VDD = 3V	50	100	200	
	RPU6	RSTB	Vin = 2V, VDD = 3V	50	100	200	
Large Pull down Resistance	RPD1	TEST	Vin = VDD, VDD = 3V	250	500	750	KΩ
Small Pull down Resistance	RPD2	TEST	Vin = 1V, VDD = 3V	1.1	2.2	3.3	KΩ
Touch Panel Pull down Resistance	RPD3	DET = 1, Xn pin	Vin = VDD, VDD = 3V	25	50	100	KΩ
Data Retention Voltage	Vret			1.6	-	-	V
Power-on Reset Voltage	Vpor			1.4	1.5	1.6	V
<b>A/D Conversion (VDD = 3.0V, AVDD = 3.0V, Ta = -10 ~ +60°C, Fclk = 12*Fsample)</b>							
<b>Analog Input</b>							
Mux Leakage Current	Imux	On/off leakage current, Vin = 0 or VDD		-	0.1	1	μA
<b>System Performance</b>							
Resolution				-	10	-	Bits
Integral Non-Linearity	INL			-2	-	+2	LSB
Differential Non-Linearity	DNL			-2	-	+2	LSB
Offset Error	OErr			-4	-	+4	LSB
Gain Error	GErr			-4	-	+4	LSB
Missing Code	MC			No missing code			Bit
AVDD Supply Current	lvdd3	AVDD = 3.0V, VDD = 3.0V, Fsample = 20kHz, ADEN = 1, VRS = 1		-	0.5	0.7	mA
	lvdd4	ADEN = 0, VRS = 1		-	-	1	uA
Driver Current	IOH	Xp, Yp (VDD = 2.9 ± 0.3V) (Voh = VDD-0.2V)		-20	-30	-45	mA
Sink Current	IOL	Xn, Yn (VDD = 2.9 ± 0.3V) (Vol = 0.2V)		+20	+30	+45	mA

Parameter	Sym.	Condition	Min	Typ	Max	Unit	
<b>Reference Voltage</b>							
Internal Reference Voltage	VRIN	AVDD = 3.0 ± 0.3V	1.8	2.0	2.2	V	
Internal Reference Supply Current	Ivrin	VDD = 3.0V, AVDD = 3.0V, VRS = 0, VOH = 0.2V	400	500	-	μA	
VREX input current	Iref1	ADEN = 1, VRS = 1	-	300	500	μA	
	Iref2	ADEN = 0, VRS = 1	-	-	1	μA	
<b>LCD Driver</b>							
Reference Voltage	Vref1	Ta = 20°C * <sup>1</sup>	2.035	2.12	2.205	V	
	Vref2	Ta = 0°C * <sup>1</sup>	2.169	2.26	2.351	V	
	Vref3	Ta = 40°C * <sup>1</sup>	1.900	1.98	2.060	V	
Charge Pump Output	Vout	2 times pumping. Capacitance of charge pump C1: 0.1μF	2*Vdd-5%	2*Vdd	-	V	
		3 times pumping. Capacitance of charge pump C1 and C2: 0.1μF	3*Vx-5%	3*Vx	-	V	
Clamping Voltage	Vx	BOOST = 0, 2 times pumping		Vdd		V	
		BOOST = 1, 3 times pumping	2.3	2.4	2.5		
Regulated Voltage	V0	VDD = 2.3V~3.3V, Ta = 25°C	V0-10%	V0 * <sup>2</sup>	V0+10%	V	
LCD Display Output ON-Resistance	ROC	Com[0:31]	VOH = V0 ± 0.2V	1	2	3	KΩ
			VOM = V1 ± 0.2V				
			VOM = V4 ± 0.2V				
			VOL = 0.2V				
LCD Display Output ON-Resistance	ROS	Seg [0 : 63, 80:111]	VOH = V0 ± 0.2V	1	2	3	KΩ
			VOM = V2 ± 0.2V				
			VOM = V3 ± 0.2V				
			VOL = 0.2V				
Strobe Output ON-Resistance	ROP	Seg [0:15] (as key strobe)	V = VDD - 0.2V	45	70	100	KΩ
	RON		V = 0.2V	0.7	1.0	1.5	
Display Frame Frequency	Frame	Sub-Clock : RC OSC	48	-	100.5	Hz	
		Sub-Clock : Crystal OSC	64	-	80.4		
Op. Amp Voltage Output of LCD Power Supply	Vout0	V0	No load	-* <sup>3</sup>	V0 * <sup>2</sup>	-* <sup>3</sup>	mV
	Vout1	V1		-* <sup>3</sup>	V1 * <sup>2</sup>	-* <sup>3</sup>	
	Vout2	V2		-* <sup>3</sup>	V2 * <sup>2</sup>	-* <sup>3</sup>	
	Vout3	V3		-* <sup>3</sup>	V3 * <sup>2</sup>	-* <sup>3</sup>	
	Vout4	V4		-* <sup>3</sup>	V4 * <sup>2</sup>	-* <sup>3</sup>	

**Note:** \*<sup>1</sup>: Typical regulated voltage for V0 is chosen by software from the following table.

\*<sup>2</sup>: V0~V4 Theoretical value

\*<sup>3</sup>: The Target value of V0~V4 is Theoretical value ± 50mV

Bias	V0	V1	V2	V3	V4
1/3	V0	2/3 * V0	1/3 * V0	2/3 * V0	1/3 * V0
1/3.5		2.5/3.5 * V0	1.5/3.5 * V0	2/3.5 * V0	1/3.5 * V0
1/4		3/4 * V0	2/4 * V0	2/4 * V0	1/4 * V0
1/4.5		3.5/4.5 * V0	2.5/4.5 * V0	2/4.5 * V0	1/4.5 * V0
1/5		4/5 * V0	3/5 * V0	2/5 * V0	1/5 * V0
1/5.5		4.5/5.5 * V0	3.5/5.5 * V0	2/5.5 * V0	1/5.5 * V0
1/6		5/6 * V0	4/6 * V0	2/6 * V0	1/6 * V0
1/6.5		5.5/6.5 * V0	4.5/6.5 * V0	2/6.5 * V0	1/6.5 * V0

## 9.4 AC Electrical Characteristics

(Condition: Ta=-10~+60°C, VDD= 3.0 ± 0.3V)

Parameter	Sym.	Condition	Min	Typ	Max	Unit
Instruction Cycle Time	Tcycle	Fmain = 1MHz	-	2 <sup>*1</sup>	-	μs
		Fmain = 4MHz	-	0.5 <sup>*1</sup>	-	
		Fmain = 10MHz	-	0.2 <sup>*1</sup>	-	
<b>A/D Conversion (VDD = 3.0V, AVDD = 3.0V, Ta = -10~+60°C)</b>						
Throughput Rate		VDD = 3.0V, AVDD = 3.0V	-	-	80	ksps
		VDD = 2.4V, AVDD = 2.4V	-	-	60	
Power Supply Rejection Ratio	PSRR1+	Power noise: 1kHz, 100mV	37	40	-	dB
	PSRR1-	Power noise: 1kHz, 100mV	43	46	-	
Signal to Noise Ratio	SNR		51	54	-	dB

Note: <sup>\*1</sup>: Instruction cycle time= 2 × System clock time

## 10 Application Circuit

(1) ELAN Product

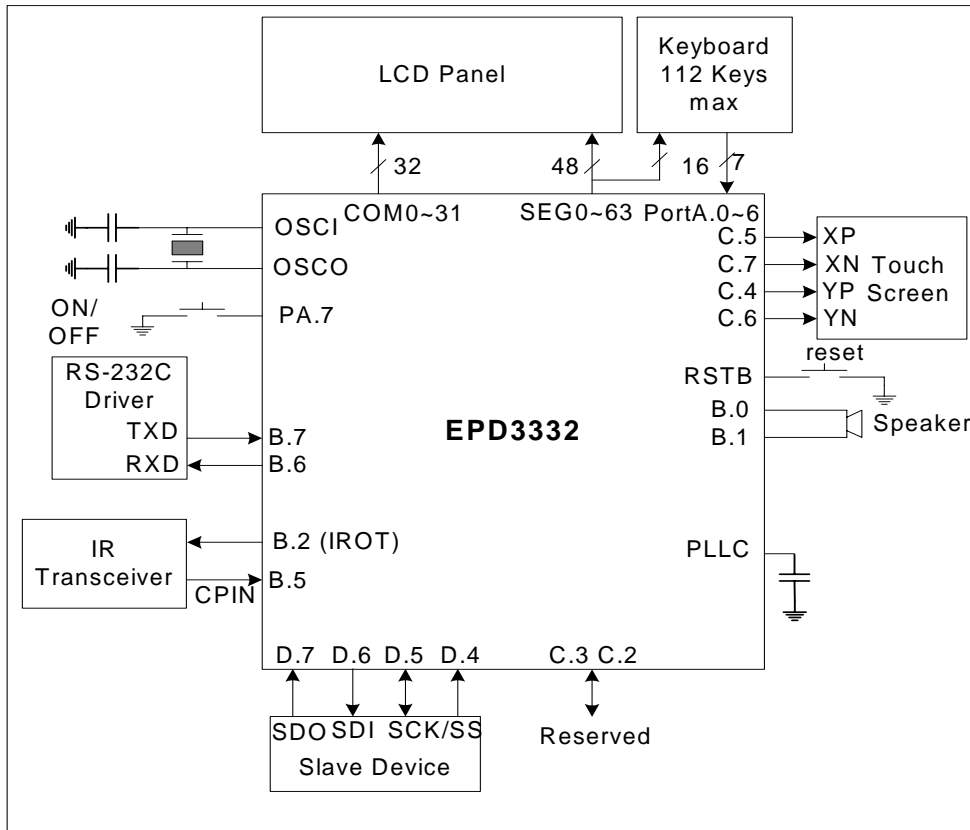

Fig. 10-1 Application Circuit Diagram

(2) 32×64 pixels driving application circuits ("Single-chip" using internal oscillator)

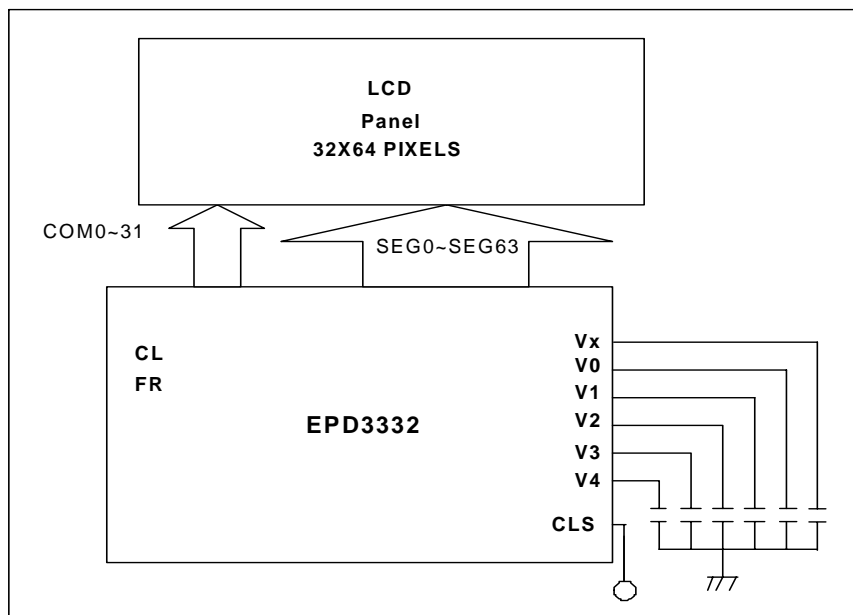
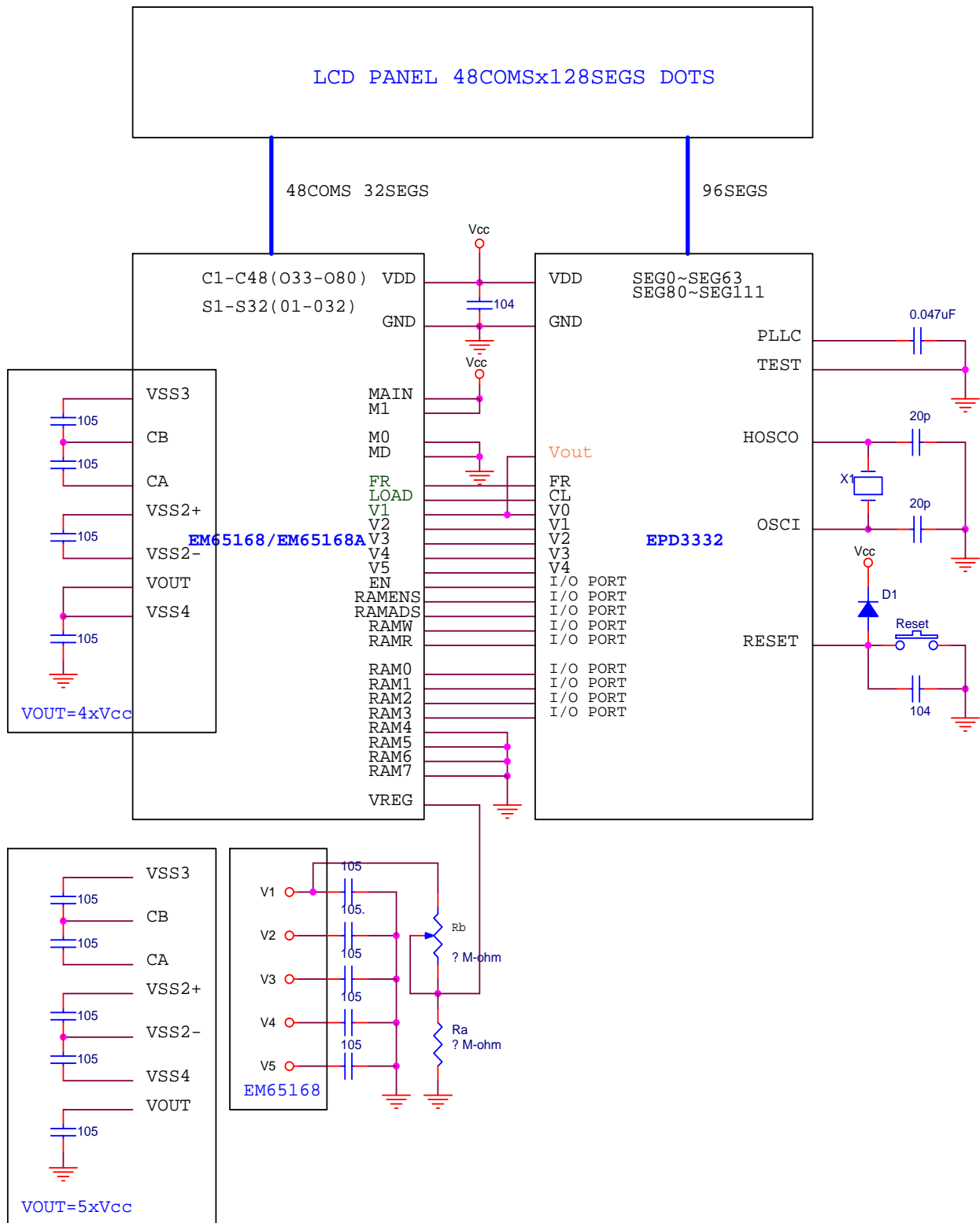

Fig. 10-2 Application Circuit Diagram

(3) 48×96 pixels driving application circuits ("Multi-chip" using with EM65168A)



## 11 Instruction Set

**Legend:** **addr:** address    **i:** Table pointer control    **p:** special file register (0h~1Fh)  
**b:** bit    **k:** constant    **r:** File Register

Type	Instruction Binary	Mnemonic	Operation	Status Affected	Cycles
System Control	0000 0000 0000 0000	NOP	No operation	None	1
	0000 0000 0000 0001	WDTC	WDT $\leftarrow$ 0; /TO $\leftarrow$ 1; /PD $\leftarrow$ 1	None	1
	0000 0000 0000 0010	SLEP	Enter IDLE MODE if MS1=1 Enter SLEEP MODE if MS1=0	None	1
	0010 0111 rrrr rrrr	RPT r	Single repeat *(r) times on next instruction *(r) is the content of register r	None	1
	0100 0011 kkkk kkkk	BANK #k	BSR $\leftarrow$ k	None	1
Rom Table Look Up	0100 0000 kkkk kkkk	TBPTL #k	TABPTRL $\leftarrow$ k	None	1
	0100 0001 kkkk kkkk	TBPTM #k	TABPTRM $\leftarrow$ k	None	1
	0100 0010 kkkk kkkk	TBPTH #k	TABPTRH $\leftarrow$ k	None	1
	0010 11 i i rrrr rrrr	TBRD i,r	r $\leftarrow$ ROM[(TABPTR)]. <b>(*1)(*2)</b>	None	2
	0010 1111 rrrr rrrr	TBRD A,r	r $\leftarrow$ ROM[(TABPTR+ACC)] <b>(*2)</b>	None	2
Data Transfer	0010 0100 rrrr rrrr	CLR r	r $\leftarrow$ 0	Z	1
	0100 1110 kkkk kkkk	MOV A,#k	A $\leftarrow$ k	None	1
	0010 0000 rrrr rrrr	MOV A,r	A $\leftarrow$ r	Z	1
	0010 0001 rrrr rrrr	MOV r,A	r $\leftarrow$ A	None	1
	100p pppp rrrr rrrr	MOV RP p,r	Register p $\leftarrow$ Register r	None	1
	101p pppp rrrr rrrr	MOV PR r,p	Register r $\leftarrow$ Register p	None	1
Exchange	0000 1111 rrrr rrrr	SWAP r	r(0:3) $\leftrightarrow$ r(4:7)	None	1
	0000 1110 rrrr rrrr	SWAPA r	r(0:3) $\rightarrow$ A(4:7); r(4:7) $\rightarrow$ A(0:3)	None	1
Bit Manipulation	0110 1bbb rrrr rrrr	BC r,b	r(b) $\leftarrow$ 0	None	1
	0111 0bbb rrrr rrrr	BS r,b	r(b) $\leftarrow$ 1	None	1
	0111 1bbb rrrr rrrr	BTG r,b	r(b) $\leftarrow$ /r(b)	None	1
Arithmetic Operation	0001 1100 rrrr rrrr	INCA r	A $\leftarrow$ r+1.	C,Z	1
	0001 1101 rrrr rrrr	INC r	r $\leftarrow$ r+1	C,Z	1
	0001 0000 rrrr rrrr	ADD A,r	A $\leftarrow$ A+r	C,DC,Z,OV,SGE,SLE	1
	0001 0001 rrrr rrrr	ADD r,A	r $\leftarrow$ r+A <b>(*4)</b>	C,DC,Z,OV,SGE,SLE	1
	0100 1010 kkkk kkkk	ADD A,#k	A $\leftarrow$ A+k	C,DC,Z,OV,SGE,SLE	1
	0001 0010 rrrr rrrr	ADC A,r	A $\leftarrow$ A+r+C	C,DC,Z,OV,SGE,SLE	1
	0001 0011 rrrr rrrr	ADC r,A	r $\leftarrow$ r+A+C	C,DC,Z,OV,SGE,SLE	1
	0100 1011 kkkk kkkk	ADC A,#k	A $\leftarrow$ A+k+C	C,DC,Z,OV,SGE,SLE	1
	0001 1110 rrrr rrrr	DECA r	A $\leftarrow$ r-1	C,Z	1
	0001 1111 rrrr rrrr	DEC r	r $\leftarrow$ r-1	C,Z	1
	0001 0110 rrrr rrrr	SUB A,r	A $\leftarrow$ r-A <b>(*6)</b>	C,DC,Z,OV,SGE,SLE	1
	0001 0111 rrrr rrrr	SUB r,A	r $\leftarrow$ r-A <b>(*6)</b>	C,DC,Z,OV,SGE,SLE	1
	0100 1100 kkkk kkkk	SUB A,#k	A $\leftarrow$ k-A <b>(*6)</b>	C,DC,Z,OV,SGE,SLE	1
	0001 1000 rrrr rrrr	SUBB A,r	A $\leftarrow$ r-A-/C <b>(*6)</b>	C,DC,Z,OV,SGE,SLE	1
	0001 1001 rrrr rrrr	SUBB r,A	r $\leftarrow$ r-A-/C <b>(*6)</b>	C,DC,Z,OV,SGE,SLE	1
	0100 1101 kkkk kkkk	SUBB A,#k	A $\leftarrow$ k-A-/C <b>(*6)</b>	C,DC,Z,OV,SGE,SLE	1

**Legend:** **addr:** address    **i:** Table pointer control    **p:** special file register (0h~1Fh)  
**b:** bit                            **k:** constant                            **r:** File Register

Type	Instruction Binary	Mnemonic	Operation	Status Affected	Cycles
Arithmetic Operation	0010 0110 rrrr rrrr	MUL A,r	PRODH:PRODL $\leftarrow$ A*r	None	1
	0100 1111 kkkk kkkk	MUL A,#k	PRODH:PRODL $\leftarrow$ A*k	None	1
	0001 0100 rrrr rrrr	ADDDC A,r	A $\leftarrow$ (Decimal ADD) A+r+C	C, DC, Z	1
	0001 0101 rrrr rrrr	ADDDC r,A	r $\leftarrow$ (Decimal ADD) r+A+C	C, DC, Z	1
	0001 1010 rrrr rrrr	SUBDB A,r	A $\leftarrow$ (Decimal SUB) r-A-/C	C, DC, Z	1
	0001 1011 rrrr rrrr	SUBDB r,A	r $\leftarrow$ (Decimal SUB) r-A-/C	C, DC, Z	1
Logic Operation	0000 0010 rrrr rrrr	OR A,r	A $\leftarrow$ A .or. r	Z	1
	0000 0011 rrrr rrrr	OR r,A	r $\leftarrow$ r .or. A	Z	1
	0100 0100 kkkk kkkk	OR A,#k	A $\leftarrow$ A .or. k	Z	1
	0000 0100 rrrr rrrr	AND A,r	A $\leftarrow$ A .and. r	Z	1
	0000 0101 rrrr rrrr	AND r,A	r $\leftarrow$ r .and. A	Z	1
	0100 0101 kkkk kkkk	AND A,#k	A $\leftarrow$ A .and. k	Z	1
	0000 0110 rrrr rrrr	XOR A,r	A $\leftarrow$ A .xor. r	Z	1
	0000 0111 rrrr rrrr	XOR r,A	r $\leftarrow$ r .xor. A	Z	1
	0100 0110 kkkk kkkk	XOR A,#k	A $\leftarrow$ A .xor. k	Z	1
	0000 1000 rrrr rrrr	COMA r	A $\leftarrow$ /r.	Z	1
	0000 1001 rrrr rrrr	COM r	r $\leftarrow$ /r.	Z	1
Rotate	0000 1010 rrrr rrrr	RRCA r	A(n-1) $\leftarrow$ r(n); C $\leftarrow$ r(0); A(7) $\leftarrow$ C	C	1
	0000 1011 rrrr rrrr	RRC r	r(n-1) $\leftarrow$ r(n); C $\leftarrow$ r(0); r(7) $\leftarrow$ C	C	1
	0000 1100 rrrr rrrr	RLCA r	A(n+1) $\leftarrow$ r(n); C $\leftarrow$ r(7); A(0) $\leftarrow$ C	C	1
	0000 1101 rrrr rrrr	RLC r	r(n+1) $\leftarrow$ r(n); C $\leftarrow$ r(7); r(0) $\leftarrow$ C	C	1
Shift	0010 0010 rrrr rrrr	SHRA r	A(n-1) $\leftarrow$ r(n); A(7) $\leftarrow$ C	None	1
	0010 0011 rrrr rrrr	SHLA r	A(n+1) $\leftarrow$ r(n); A(0) $\leftarrow$ C	None	1
Bit Compare & Jump	0101 1bbb rrrr rrrr aaaa aaaa aaaa aaaa	JBC r,b,addr	If r(b)=0, jump to addr; PC[15:0] $\leftarrow$ addr. (*3)	None	2
	0110 0bbb rrrr rrrr aaaa aaaa aaaa aaaa	JBS r,b,addr	If r(b)=1, jump to addr; PC[15:0] $\leftarrow$ addr. (*3)	None	2
Compare	0010 0101 rrrr rrrr	TEST r	Z $\leftarrow$ 0 if r<>0; Z $\leftarrow$ 1 if r=0	Z	1
Compare & Jump	0101 0000 rrrr rrrr aaaa aaaa aaaa aaaa	JDNZ A,r,addr	A $\leftarrow$ r-1, jump to addr if not zero; PC [15:0] $\leftarrow$ addr. (*3)	None	2
	0101 0001 rrrr rrrr aaaa aaaa aaaa aaaa	JDNZ r,addr	r $\leftarrow$ r-1, jump to addr if not zero; PC [15:0] $\leftarrow$ addr. (*3)	None	2
	0101 0010 rrrr rrrr aaaa aaaa aaaa aaaa	JINZ A,r,addr	A $\leftarrow$ r+1, jump to addr if not zero; PC[15:0] $\leftarrow$ addr. (*3)	None	2
	0101 0011 rrrr rrrr aaaa aaaa aaaa aaaa	JINZ r,addr	r $\leftarrow$ r+1, jump to addr if not zero; PC[15:0] $\leftarrow$ addr. (*3)	None	2
	0100 0111 kkkk kkkk aaaa aaaa aaaa aaaa	JGE A,#k,addr	Jump to addr if A $\geq$ k; PC [15:0] $\leftarrow$ addr. (*3)	None	2
	0100 1000 kkkk kkkk aaaa aaaa aaaa aaaa	JLE A,#k,addr	Jump to addr if A $\leq$ k; PC [15:0] $\leftarrow$ addr. (*3)	None	2
	0100 1001 kkkk kkkk aaaa aaaa aaaa aaaa	JE A,#k,addr	Jump to addr if A=k; PC[15:0] $\leftarrow$ addr. (*3)	None	2

**Legend:** **addr:** address    **i:** Table pointer control    **p:** special file register (0h~1Fh)  
**b:** bit    **k:** constant    **r:** File Register

Type	Instruction Binary	Mnemonic	Operation	Status Affected	Cycles
Compare & Jump	0101 0101 rrrr rrrr aaaa aaaa aaaa aaaa	JGE A,r,addr	Jump to addr if $A \geq r$ ; PC[15:0] $\leftarrow$ addr. (*3)	None	2
	0101 0110 rrrr rrrr aaaa aaaa aaaa aaaa	JLE A,r,addr	Jump to addr if $A \leq r$ ; PC[15:0] $\leftarrow$ addr. (*3)	None	2
	0101 0111 rrrr rrrr aaaa aaaa aaaa aaaa	JE A,r,addr	Jump to addr if $A=r$ ; PC[15:0] $\leftarrow$ addr. (*3)	None	2
Jump	110a aaaa aaaa aaaa	SJMP addr	PC $\leftarrow$ addr; PC [13..16] unchanged	None	1
	0000 0000 0010 aaaa aaaa aaaa aaaa aaaa	LJMP addr (2 words)	PC $\leftarrow$ addr.	None	2
Subroutine	0011 aaaa aaaa aaaa	S0CALL addr	Top of Stack $\leftarrow$ PC+1; PC [11:0] $\leftarrow$ addr; PC [12:16] $\leftarrow$ 00000 (*5)	None	1
	111a aaaa aaaa aaaa	SCALL addr	[Top of Stack] $\leftarrow$ PC+1; PC [12:0] $\leftarrow$ addr; PC [13:16] unchanged.	None	1
	0000 0000 0011 aaaa aaaa aaaa aaaa aaaa	LCALL addr (2 words)	[Top of Stack] $\leftarrow$ PC+1; PC $\leftarrow$ addr	None	2
	0010 1011 1111 1110	RET	PC $\leftarrow$ (Top of Stack)	None	1
	0010 1011 1111 1111	RETI	PC $\leftarrow$ (Top of Stack); Enable Interrupt	None	1

(\*1) TBRD i, r:

$r \leftarrow$  ROM [(TABPTR)];

i=00: TABPTR no change

i=01: TABPTR  $\leftarrow$  TABPTR+1

i=10: TABPTR  $\leftarrow$  TABPTR-1

(\*2) TABPTR=(TABPTRH: TABPTRM: TABPTRL)

Bit 0 = 0: Low byte of the pointed ROM data

Bit 0 = 1: High byte of the pointed ROM data

The maximum table look up space is internal 8Mbytes.

(\*3) The maximum jump range is 64K absolute address, which means it can only jump within the same 64K range.

(\*4) Carry bit of ADD PCL, A or ADD TABPTRL, A will automatically carry into PCM or TABPTRM.  
The Instruction cycle for writing to the PC (program counter) takes 2 cycles.

(\*5) S0CALL address ability is from 0x000 to 0xFFFF (4K space).

(\*6) When in SUB operation, borrow flag is indicated by the inverse of carry bit, i.e., B = /C.

## 12 Pad Diagram

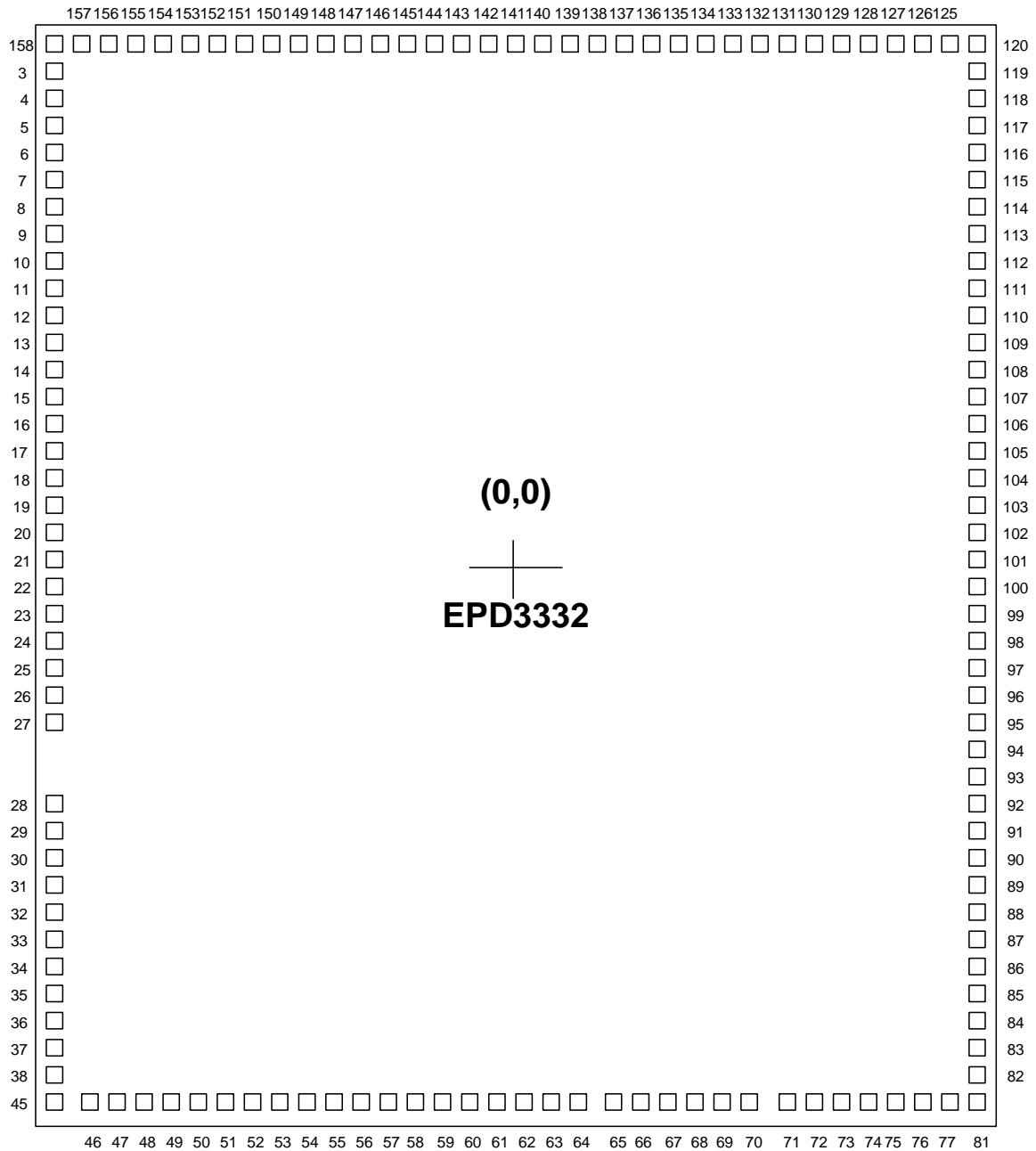

Fig. 12-1 EPD3332 Pad Locations

Chip size:  $3870 * 4470 \mu\text{m}^2$



Pin No.	Symbol	X	Y	Pin No.	Symbol	X	Y
1	NC			81	COM_17	1804.6	-2105.0
2	NC			82	COM_16	1804.6	-1980.0
3	COM_8	-1806.8	1984.9	83	PH_7	1804.6	-1875.0
4	COM_9	-1806.8	1874.9	84	PH_6	1804.6	-1765.0
5	COM_10	-1806.8	1760.9	85	PH_5	1804.6	-1655.0
6	COM_11	-1806.8	1646.9	86	PH_4	1804.6	-1545.0
7	COM_12	-1806.8	1532.9	87	PH_3	1804.6	-1435.0
8	COM_13	-1806.8	1418.9	88	PH_2	1804.6	-1330.0
9	COM_14	-1806.8	1304.9	89	PH_1	1804.6	-1225.0
10	COM_15	-1806.8	1194.9	90	PH_0	1804.6	-1120.0
11	VOUT	-1806.8	1089.9	91	PG_7	1804.6	-1015.0
12	VX	-1806.8	984.9	92	PG_6	1804.6	-910.0
13	VR	-1806.8	879.9	93	PG_5	1804.6	-805.0
14	V1	-1806.8	774.9	94	PG_4	1804.6	-700.0
15	V2	-1806.8	669.9	95	PG_3	1804.6	-595.0
16	V3	-1806.8	564.9	96	PG_2	1804.6	-490.0
17	V4	-1806.8	459.9	97	PG_1	1804.6	-385.0
18	C1P	-1806.8	354.9	98	PG_0	1804.6	-280.0
19	C1N	-1806.8	249.9	99	SEG_47	1804.6	-175.0
20	C2P	-1806.8	144.9	100	SEG_46	1804.6	-70.0
21	C2N	-1806.8	39.9	101	SEG_45	1804.6	35.0
22	V0A	-1806.8	-65.1	102	SEG_44	1804.6	140.0
23	FR	-1806.8	-170.1	103	SEG_43	1804.6	245.0
24	CL	-1806.8	-275.1	104	SEG_42	1804.6	350.0
25	TEST	-1806.8	-382.3	105	SEG_41	1804.6	455.0
26	PLL	-1806.8	-492.3	106	SEG_40	1804.6	560.0
27	OSCI	-1806.8	-597.3	107	SEG_39	1804.6	665.0
28	OSCO	-1806.8	-905.2	108	SEG_38	1804.6	770.0
29	RSTB	-1806.8	-1015.0	109	SEG_37	1804.6	875.0
30	VDD	-1806.8	-1120.0	110	SEG_36	1804.6	980.0
31	PB_0	-1806.8	-1228.5	111	SEG_35	1804.6	1085.0
32	PB_1	-1806.8	-1337.6	112	SEG_34	1804.6	1190.0
33	GND	-1806.8	-1447.0	113	SEG_33	1804.6	1295.0
34	PB_2	-1806.8	-1554.0	114	SEG_32	1804.6	1409.0
35	PB_5	-1806.8	-1661.0	115	SEG_31	1804.6	1522.9
36	PB_6	-1806.8	-1768.0	116	SEG_30	1804.6	1637.0
37	PB_7	1806.8	-1875.0	117	SEG_29	1804.6	1751.0
38	PC_2	1806.8	-1980.0	118	SEG_28	1804.6	1865.0
39	NC			119	SEG_27	1804.6	1981.5
40	NC			120	SEG_26	1804.6	2104.9
41	NC			121	NC		
42	NC			122	NC		



Pin No.	Symbol	X	Y	Pin No.	Symbol	X	Y
43	NC			123	NC		
44	NC			124	NC		
45	PC_3	-1806.8	-2105.0	125	SEG_25	1684.6	2104.9
46	PC_4	-1681.8	-2105.0	126	SEG_24	1563.1	2104.9
47	PC_5	-1566.8	-2105.0	127	SEG_23	1458.1	2104.9
48	PC_6	-1456.8	-2105.0	128	SEG_22	1353.1	2104.9
49	PC_7	-1346.8	-2105.0	129	SEG_21	1248.1	2104.9
50	VREX	-1231.8	-2105.0	130	SEG_20	1143.1	2104.9
51	VDD	-1116.8	-2105.0	131	SEG_19	1038.1	2104.9
52	PD_7	-1006.2	-2105.0	132	SEG_18	933.1	2104.9
53	PD_6	-901.2	-2105.0	133	SEG_17	828.1	2104.9
54	PD_5	-796.2	-2105.0	134	SEG_16	723.1	2104.9
55	PD_4	-686.2	-2105.0	135	SEG_15	618.1	2104.9
56	PA_7	-576.2	-2105.0	136	SEG_14	513.1	2104.9
57	PA_6	-466.2	-2105.0	137	SEG_13	408.1	2104.9
58	PA_5	-361.1	-2105.0	138	SEG_12	303.1	2104.9
59	PA_4	-256.0	-2105.0	139	SEG_11	198.1	2104.9
60	PA_3	-150.9	-2105.0	140	SEG_10	93.1	2104.9
61	PA_2	-45.8	-2105.0	141	SEG_9	-11.9	2104.9
62	PA_1	59.3	-2105.0	142	SEG_8	-116.9	2104.9
63	PA_0	164.4	-2105.0	143	SEG_7	-221.9	2104.9
64	COM_31	269.5	-2105.0	144	SEG_6	-326.9	2104.9
65	COM_30	374.6	-2105.0	145	SEG_5	-431.9	2104.9
66	COM_29	479.6	-2105.0	146	SEG_4	-536.9	2104.9
67	COM_28	584.6	-2105.0	147	SEG_3	-641.9	2104.9
68	COM_27	689.6	-2105.0	148	SEG_2	-746.9	2104.9
69	COM_26	794.6	-2105.0	149	SEG_1	-851.9	2104.9
70	COM_25	899.6	-2105.0	150	SEG_0	-956.9	2104.9
71	COM_24	1004.6	-2105.0	151	COM_0	-1061.9	2104.9
72	COM_23	1114.6	-2105.0	152	COM_1	-1166.9	2104.9
73	COM_22	1224.6	-2105.0	153	COM_2	-1271.9	2104.9
74	COM_21	1344.6	-2105.0	154	COM_3	-1376.9	2104.9
75	COM_20	1454.6	-2105.0	155	COM_4	-1481.9	2104.9
76	COM_19	1564.6	-2105.0	156	COM_5	-1586.9	2104.9
77	COM_18	1679.6	-2105.0	157	COM_6	-1691.8	2104.9
78	NC			158	COM_7	-1806.8	2104.9
79	NC			159	NC		
80	NC			160	NC		

For PCB layout, the IC substrate must be connected to VSS.

