EPD2012

RISC II Series Microcontroller

Product Specification

DOC. VERSION 0.2

ELAN MICROELECTRONICS CORP.

October 2009



Trademark Acknowledgments:

IBM is a registered trademark and PS/2 is a trademark of IBM.

Windows is a trademark of Microsoft Corporation.

ELAN and ELAN logo  are trademarks of ELAN Microelectronics Corporation.

Copyright © 2007~2009 by **ELAN Microelectronics Corporation**

All Rights Reserved

Printed in Taiwan

The contents of this specification are subject to change without further notice. ELAN Microelectronics assumes no responsibility concerning the accuracy, adequacy, or completeness of this specification. ELAN Microelectronics makes no commitment to update, or to keep current the information and material contained in this specification. Such information and material may change to conform to each confirmed order.

In no event shall ELAN Microelectronics be made responsible for any claims attributed to errors, omissions, or other inaccuracies in the information or material contained in this specification. ELAN Microelectronics shall not be liable for direct, indirect, special incidental, or consequential damages arising from the use of such information or material.

The software (if any) described in this specification is furnished under a license or nondisclosure agreement, and may be used or copied only in accordance with the terms of such agreement.

ELAN Microelectronics products are not intended for use in life support appliances, devices, or systems. Use of ELAN Microelectronics product in such applications is not supported and is prohibited.

NO PART OF THIS SPECIFICATION MAY BE REPRODUCED OR TRANSMITTED IN ANY FORM OR BY ANY MEANS WITHOUT THE EXPRESSED WRITTEN PERMISSION OF ELAN MICROELECTRONICS.



ELAN MICROELECTRONICS CORPORATION

Headquarters:

No. 12, Innovation 1st Road
Hsinchu Science Park
Hsinchu, TAIWAN 30076
Tel: +886 3 563-9977
Fax: +886 3 563-9966
webmaster@emc.com.tw
<http://www.emc.com.tw>

Hong Kong:

Elan (HK) Microelectronics Corporation, Ltd.
Flat A, 19F., World Tech Centre
95 How Ming Street, Kwun Tong
Kowloon, HONG KONG
Tel: +852 2723-3376
Fax: +852 2723-7780

USA:

Elan Information Technology Group (U.S.A.)
PO Box 601
Cupertino, CA 95015
U.S.A.
Tel: +1 408 366-8225
Fax: +1 408 366-8225

Shenzhen:

Elan Microelectronics Shenzhen, Ltd.
3F, SSMEC Bldg., Gaoxin S. Ave. I
Shenzhen Hi-tech Industrial Park
(South Area), Shenzhen
CHINA 518057
Tel: +86 755 2601-0565
Fax: +86 755 2601-0500
elan-sz@elan.com.cn

Shanghai:

Elan Microelectronics Shanghai, Ltd.
#34, First Fl., 2nd Bldg.,
Lane 122, Chunxiao Rd.
Zhangjiang Hi-Tech Park
Shanghai, CHINA 201203
Tel: +86 21 5080-3866
Fax: +86 21 5080-4600
elan-sh@elan.com.cn

Contents

1	General Description	1
1.1	Applications	2
2	Features	2
2.1	MCU Features	2
2.2	Peripheral	2
2.3	Internal Specification	3
2.4	Elan Software Support (Optional).....	3
3	Block Diagram	Error! Bookmark not defined.
4	Pin Assignment.....	5
5	Pin Description	6
5.1	MCU System Pins (9 Pins).....	6
5.2	Embedded LCD Pins (94 Pins)	6
5.3	I/O Ports (40 Pins).....	7
6	Code Option	8
7	MCU System.....	10
7.1	Power-up and Reset Timing	10
7.2	MCU Operation Timing.....	10
8	ROM and RAM.....	11
8.1	Program ROM Map	11
8.2	Data ROM Map	11
8.3	RAM Map	12
8.4	LCD RAM Map	12
9	Electrical Characteristics.....	13
9.1	Absolute Maximum Ratings.....	13
9.2	Recommended Operating Conditions	13
9.3	DC Electrical Characteristics	13
9.4	AC Electrical Characteristics	17
10	Application Circuits.....	18

Specification Revision History

Doc. Version	Revision Description	Date
0.1	Initial version	2007/03/29
0.2	<ol style="list-style-type: none">1. Added a new circuit on the current consumption application.2. Modified the DC Characteristics for Idle 4 LCD enable condition.	2009/10/15

PRELIMINARY

1 General Description

The **EPD2012** is an 8-bit RISC MCU embedded with the following features:

- 10-bit SAR A/D converter with touch screen controller
- Analog front end, 32×64 LCD driver
- Two 8-bit timers and one 16-bit general timer with capture and event counter functions
- Embedded large size user RAM and program/data memory
- Watchdog timer, SPI, UART, and four melody timers
- PWM or current D/A
- IR generator

The **EPD2012** is ideally suitable for educational learning tools application that requires high performance and low cost solution.

The MCU core is ELAN's second generation RISC (RISC II) based IC. The core is specifically designed as a low power and portable device. It supports Fast, Slow, and Idle mode, as well as Sleep mode for low power consumption application.

IMPORTANT NOTES

- Do not use Register BSR (05h) Bit 7 ~ Bit 4.
- Do not use Register BSR1 (07h) Bit 7 ~ Bit 4.
- Do not use Special Register (04h).
- Do not use Special Register (1Bh).
- Do not use Special Register (1Ch).
- Do not use Special Register (1Fh).
- Do not use Special Register (2Ah).
- Do not use Special Register (32h).
- Do not use Special Register (33h).
- Do not use Special Register (39h).
- Do not use Special Register (4Fh).
- Do not use LCD RAM Page 00 (40h~4Fh).
- Do not use LCD RAM Page 01 (40h~4Fh).
- Do not use LCD RAM Page 02 (40h~4Fh).
- Do not use LCD RAM Page 03 (40h~4Fh).
- Do not use LCD RAM Page 04 (40h~4Fh).
- Do not use LCD RAM Page 05 (40h~4Fh).
- Do not use Port B.3~4.
- Do not use Port C.0~1.
- Do not use Port D.0~3.
- Do not use JDNZ and JINZ at FSR1 (09h) special register.
- Do not use Register TABPTRH (0Dh) Bit 6.

1.1 Applications

- Educational Learning Tools
- Kids PDA, Kids computer
- Electronics book
- Dictionary, Data Bank

2 Features

2.1 MCU Features

- 8 bit RISC MCU
- 8×8 multiplier with controllable signed or unsigned operation
- Operating voltage and speed: 16~11 MHz @ 2.9V~3.6V, 10 MHz @ 2.2V~3.6V
- One Instruction cycle time = 2 × System clock time
- Program ROM addressing: 64K words max.
- Data ROM addressing: 256K words max.
- 128 bytes un-banked RAM including special registers and common registers
- 12×128 bytes banked RAM
- RAM stack has a maximum of 128 levels
- Look-up Table function is fast and highly efficient when implemented with Repeat instruction
- Register-to-Register move instruction
- Compare and Branch in one instruction (2 cycles)
- Single Repeat function (256 repeat times max.)
- Decimal Add and Sub instruction
- Full range Call and Jump capability (2 cycles)

2.2 Peripheral

- One input port (Port A) and 32 general I/O pins (Port B.7~5, Port B.2~0, Port C.7~2, Port D.7~4, Port G ~ Port H)
- 4-channel Melody/Speech Synthesizer
- 32 COM × 64 SEG LCD driver embedded or supplied with 96 segments for external LCD driver that is compatible with EM65168 which has 48 COM × (96+32) SEG.
- 16-bit timer (Timer 0) with capture and event counter functions

- 8-bit timer (Timer 1) with wake-up function
- 8-bit timer (Timer 2) as beat counter for Melody function
- 8-bit IR generator
- 8-bit PWM and a current D/A for melody and speech application
- 8-bit Watchdog Timer
- 10 bits resolution SAR A/D converter with four channels general analog input and two channels for touch panel application
- Key I/O function with 112 keys maximum
- SPI (Serial Peripheral Interface)
- UART (Universal Asynchronous Receiver and Transmitter)

2.3 Internal Specification

- Watchdog Timer with on-chip RC oscillator
- MCU mode: Sleep Mode, Idle Mode, Slow Mode, and Fast Mode
- Supports RC oscillation and crystal oscillation for system clock
- PLL is turned on in Fast mode, and controlled by the PEN bit when the MCU is in Slow mode and Idle mode
- MCU Wake-up function includes input wake up, Timer 1 wake up, touch panel wake up, SPI wake up, and A/D wake up
- MCU interrupt function includes Input port interrupt, touch panel interrupt, Capture interrupt, speech timer interrupt, Timer interrupt (Timers 0~2), A/D interrupt, SPI interrupt and UART interrupt
- MCU reset function includes power-on reset, RSTB pin reset, and Watchdog timer reset

2.4 Elan Software Support (Optional)

- LCD display
- 4-channel Melody or 3-channel Melody + 1-channel Speech
- ADPCM decoder
- ADPCM encoder

3 Block Diagram

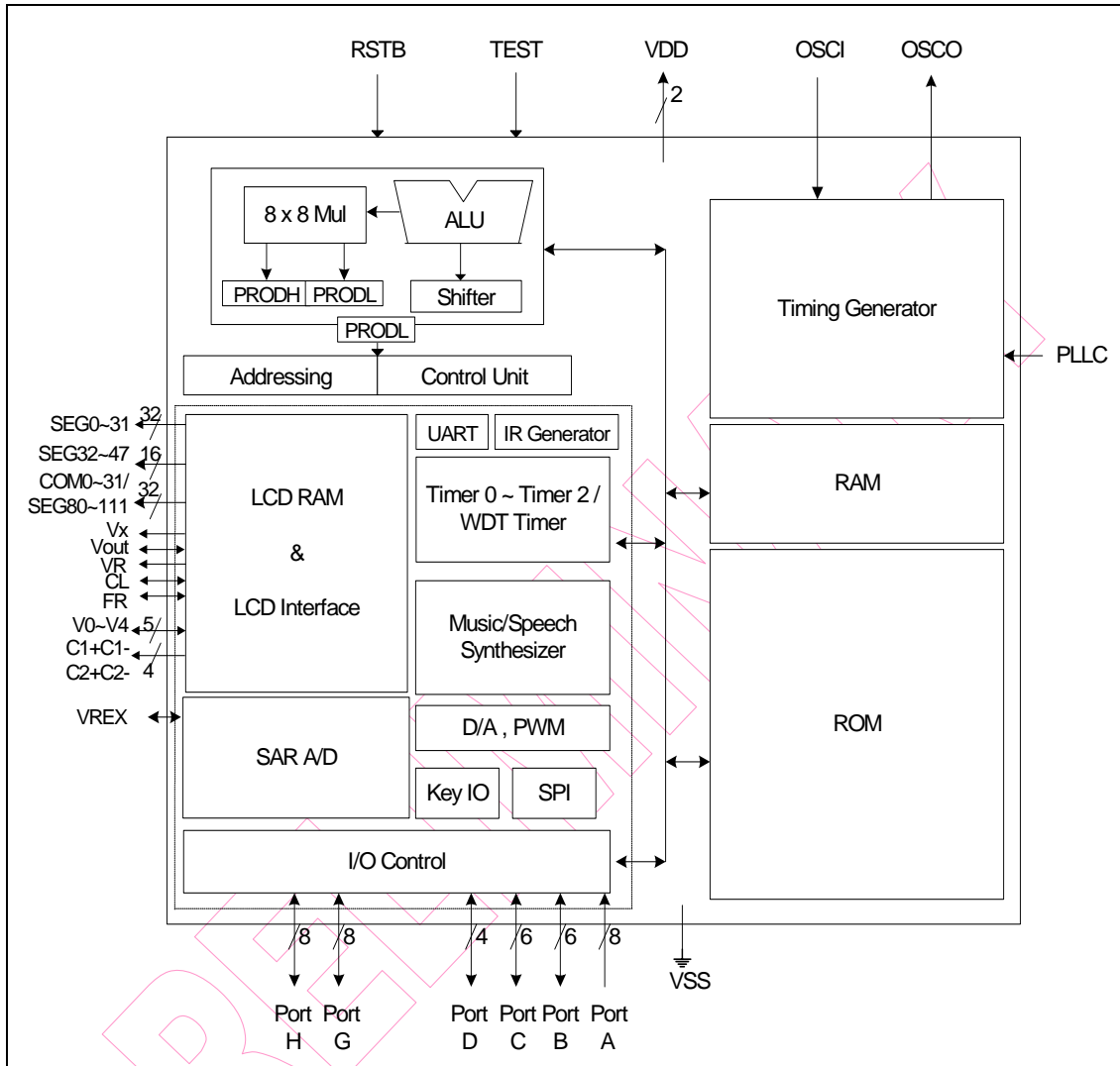
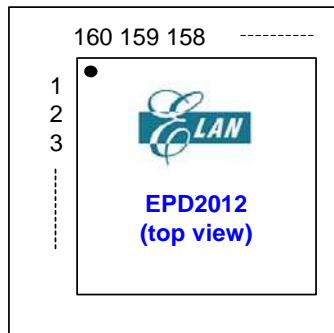

Figure 3-1 EPD2012 Block Diagram

4 Pin Assignment



No.	Pin Name	No.	Pin Name	No.	Pin Name	No.	Pin Name
1	N.C.	41	N.C	81	COM17/SEG81	121	N.C.
2	N.C.	42	N.C	82	COM16/SEG80	122	N.C.
3	COM8/SEG103	43	N.C	83	PH.7 (SEG63)	123	N.C.
4	COM9/SEG102	44	N.C	84	PH.6 (SEG62)	124	N.C.
5	COM10/SEG101	45	PC.3 (ADIN5)	85	PH.5 (SEG61)	125	SEG25
6	COM11/SEG100	46	PC.4 (ADIN4/YP)	86	PH.4 (SEG60)	126	SEG24
7	COM12/SEG99	47	PC.5 (ADIN3/XP)	87	PH.3 (SEG59)	127	SEG23
8	COM13/SEG98	48	PC.6 (YN)	88	PH.2 (SEG58)	128	SEG22
9	COM14/SEG97	49	PC.7 (XN)	89	PH.1 (SEG57)	129	SEG21
10	COM15/SEG96	50	VREX	90	PH.0 (SEG56)	130	SEG20
11	VOUT	51	VDD	91	PG.7 (SEG55)	131	SEG19
12	Vx	52	PD.7 (SPISDI)	92	PG.6 (SEG54)	132	SEG18
13	VR	53	PD.6 (SPISDO)	93	PG.5 (SEG53)	133	SEG17
14	V1	54	PD.5 (SPISCK)	94	PG.4 (SEG52)	134	SEG16
15	V2	55	PD.4 (SPISS)	95	PG.3 (SEG51)	135	SEG15 (Strobe 15)
16	V3	56	PA.7	96	PG.2 (SEG50)	136	SEG14 (Strobe 14)
17	V4	57	PA.6	97	PG.1 (SEG49)	137	SEG13 (Strobe 13)
18	C1+	58	PA.5	98	PG.0 (SEG48)	138	SEG12 (Strobe 12)
19	C1-	59	PA.4	99	SEG47	139	SEG11 (Strobe 11)
20	C2+	60	PA.3	100	SEG46	140	SEG10 (Strobe 10)
21	C2-	61	PA.2	101	SEG45	141	SEG9 (Strobe 9)
22	V0	62	PA.1	102	SEG44	142	SEG8 (Strobe 8)
23	FR	63	PA.0	103	SEG43	143	SEG7 (Strobe 7)
24	CL	64	COM31/SEG95	104	SEG42	144	SEG6 (Strobe 6)
25	TEST	65	COM30/SEG94	105	SEG41	145	SEG5 (Strobe 5)
26	PLL	66	COM29/SEG93	106	SEG40	146	SEG4 (Strobe 4)
27	OSCI	67	COM28/SEG92	107	SEG39	147	SEG3 (Strobe 3)
28	OSCO	68	COM27/SEG91	108	SEG38	148	SEG2 (Strobe 2)
29	RSTB	69	COM26/SEG90	109	SEG37	149	SEG1 (Strobe 1)
30	VDD	70	COM25/SEG89	110	SEG36	150	SEG0 (Strobe 0)
31	PB.0 (VO2)	71	COM24/SEG88	111	SEG35	151	COM0 (SEG111)
32	PB.1 (VO1/DAO)	72	COM23/SEG87	112	SEG34	152	COM1 (SEG110)
33	VSS	73	COM22/SEG86	113	SEG33	153	COM2 (SEG109)
34	PB.2 (IROT)	74	COM21/SEG85	114	SEG32	154	COM3 (SEG108)
35	PB.5 (EVIN/CPIN)	75	COM20/SEG84	115	SEG31	155	COM4 (SEG107)
36	PB.6 (UTXD)	76	COM19/SEG83	116	SEG30	156	COM5 (SEG106)
37	PB.7 (URXD)	77	COM18/SEG82	117	SEG29	157	COM6 (SEG105)
38	PC.2 (ADIN6)	78	N.C.	118	SEG28	158	COM7 (SEG104)
39	N.C.	79	N.C.	119	SEG27	159	N.C.
40	N.C.	80	N.C.	120	SEG26	160	N.C.

5 Pin Description

5.1 MCU System Pins (9 Pins)

Name	I/O/P Type	Description
VDD VSS	P	Digital and Analog positive power supply, ranging from 2.2V~3.6V. Connect to VSS through the 0.1 μ F capacitor.
RSTB	I	System reset input with built-in pull-up resistor (100K Ω Typical) Low: RESET asserted High: RESET released
TEST	I	Normally connect to VSS, reserved for testing.
OSCI/RC OSCO	I O	RC or Crystal selection by Code Option 32768 Hz oscillator pins. Connect to VSS through the 20pF capacitor. RC oscillator connector pin. Connect to VDD through the 2 M Ω resistor.
PLLC	I	PLL capacitor connector pin. Connect to VSS through the 0.047 μ F capacitor.
VREX	I/O	External or internal reference voltage for A/D converter. Connect to VSS through the 0.1 μ F capacitors.

5.2 Embedded LCD Pins (94 Pins)

Name	I/O/P Type	Description
COM0~COM31/ SEG80~SEG111	O	LCD common/segment signal output pin Multiplexed: Common and segment pin
SEG0~SEG47	O	LCD segment signal output pin (SEG0~SEG15 are shared with key strobe)
CL	I/O	Display clock input/output pin
FR	I/O	LCD frame signal input/output pin
Vx	-	Clamping circuit output voltage. Ext. C (0.1 μ F) to VSS
Vout	-	Charge pump output voltage. Ext. C (0.22 μ F) to VSS
VR	-	V0 voltage adjusting pin
V0~V4	O	LCD bias pin. Ext. C (0.1 μ F) to VSS
C1+, C1-, C2+, C2-	-	Charge pump capacitor (0.1 μ F)

5.3 I/O Ports (40 Pins)

Name	I/O/P Type	Description
Port A	I	General Input port for special functions, i.e., Wake-up and Interrupt Bit 7: ON key input Bits 6~0: Key matrix input pins
Port B (7~5, 2~0)	I/O I O I O O O	General Input/Output port Bit 7: UART Rx pin Bit 6: UART Tx pin Bit 5: Event counter/Capture input pin Bit 2: IR output pin Bit 1: PWM or Current D/A output pin Bit 0: PWM output pin
Port C (7~2)	I/O O O I I I I	General Input/Output port Bit 7: Touch screen X direction negative pin Bit 6: Touch screen Y direction negative pin Bit 5: Touch screen X direction positive pin and A/D Input Channel 3 Bit 4: Touch screen Y direction positive pin and A/D Input Channel 4 Bit 3: A/D input Channel 5 Bit 2: A/D input Channel 6
Port D (7~4)	I/O I O I/O I	General Input/Output port Bit 7: Serial data input pin Bit 6: Serial data output pin Bit 5: Serial clock Input/Output pin Bit 4: /Slave Select pin
Port G	I/O O	General Input/Output port SEG 55~48: LCD segment signal output pins
Port H	I/O O	General Input/Output port SEG 63~56: LCD segment signal output pins



6 Code Option

Located at the address 0x000C~0x0013 of the Program ROM:

- Oscillator (OSCSEL): "RC" oscillator
"Crystal" oscillator **(Default)**
- Initial mode after reset: "Slow" mode
"Fast" mode **(Default)**
- Port C.7 function selection bit: "XN for touch panel"
"General I/O function" **(Default)**
- Port C.6 function selection bit: "YN for touch panel"
"General I/O function" **(Default)**
- Port C.5 function selection bit: "XP for touch panel/ADIN3"
"General I/O function" **(Default)**
- Port C.4 function selection bit: "YP for touch panel/ADIN4"
"General I/O function" **(Default)**
- Port C.3 function selection bit: "ADIN5"
"General I/O function" **(Default)**
- Port C.2 function selection bit: "ADIN6"
"General I/O function" **(Default)**
- DAC and PWM function selection bits:

DAC or PWM Function Selection	Port B.0 and Port B.1 Function
DAC is used	Port B.1 is DAO for D/A, Port B.0 is General I/O
PWM is used	Port B.1 is VO1 and Port B.0 is VO2 for PWM
DAC and PWM are prohibited for use	General I/O (Default)

- Duty Ratio: Maximum Duty Ratio Option **(1/32, Default)**
COM 8-15/SEG 103-96; COM 16-23/SEG 87-80 and COM 24-31/SEG 95-88
status setting

Duty Ratio	Display Size (max.)	Common Driver Used			
		COM 0~7	COM 8~15/ SEG 103~96	COM 16~23/ SEG 87~80	COM 24~31/ SEG 95~88
1/4	88 × 4	COM 0~7	SEG103~96	SEG87~80	SEG95~88
1/8	88 × 8	COM 0~7	SEG103~96	SEG87~80	SEG95~88
1/9	80 × 9	COM 0~15		SEG87~80	SEG95~88
1/11	80 × 11	COM 0~15		SEG 87~80	SEG 95~88
1/16	80 × 16	COM 0~15		SEG 87~80	SEG 95~88
1/24	72 × 24	COM 0~23			SEG 95~88
1/32	64 × 32	COM 0~31			
1/48	128 × 48	SEG 64~95 *			

* The COM pins are supplied as SEG and combined with EM65168A 32 SEG pins, the total is 128 SEG.

- V1; V2; V3 & V4 OP Buffer: “ON (Normal current)” **(Default)**
“OFF” , “1/3 bias (Small current)”
- V0 OP buffer control bit: “V0 OP buffer turn off”
“V0 OP buffer turn on” **(Default)**
- LCD master / slave mode select bit: “LCD master mode” **(Default)**
“LCD slave mode”
- FR clock source select bit within LCD slave mode: “From internal” **(Default)**
“From external”
- LCD data latch edge select bit: “CL pin falling edge” **(Default)**
“CL pin rising edge”

LCDLAH: LCD Data Latch Edge Select Bit

CLS	FRS	LCDLAH	CL Pin	FR Pin	Data Latch	Remark
0	×	0	Output	Output	At CL falling edge	LCD master mode
	×	1	Output	Output	At CL rising edge	LCD master mode
1	0	0	Input	No connection	At CL falling edge	LCD slave mode
	0	1	Input	No connection	At CL rising edge	LCD slave mode
	1	0	Input	Input	At CL falling edge	LCD slave mode
	1	1	Input	Input	At CL rising edge	LCD slave mode

- Port G low nibble control bits : “LCD segment signal output” **(Default)**
“General I/O function”
- Port G high nibble control bits : “LCD segment signal output” **(Default)**
“General I/O function”
- Port H low nibble control bits : “LCD segment signal output” **(Default)**
“General I/O function”
- Port H high nibble control bits: “LCD segment signal output” **(Default)**
“General I/O function”
- Select UART standard baud rate: “PLL frequency is 9.83 MHz” **(Default)**
“PLL frequency is 14.745 MHz”
- Read Port A control bit: “Port A connected with LCD-BitST”
“Port A divided from LCD-BitST” **(Default)**

NOTE

The read Port A control of the code option can be used only on the PMPD38 or PMPD33B PM board.

7 MCU System

7.1 Power-up and Reset Timing

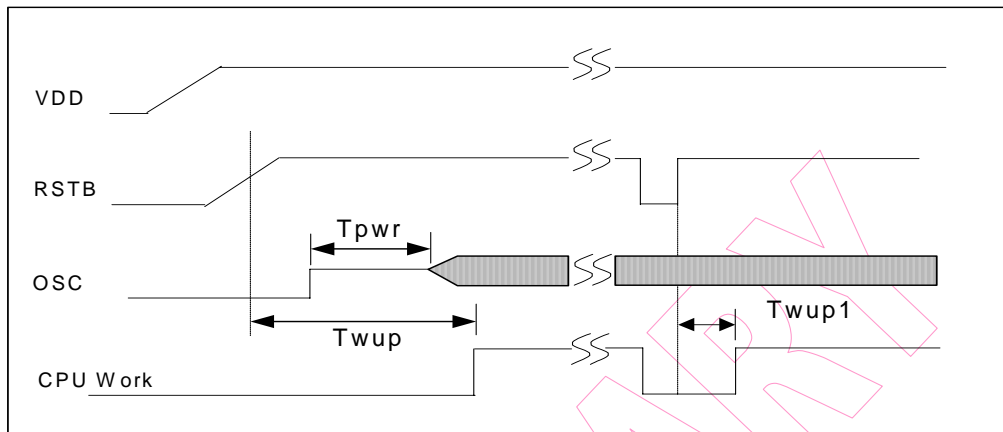

Figure 7-1 Power-up and Reset Timing

Symbol	Characteristics	Min.	Typ.	Max.	Unit
Tpwr	Oscillator start up time	100	226	300	ms
Twup	CPU warm up time	260	340	550	ms
Twup1	CPU reset time	18	22	44	ms

7.2 MCU Operation Timing

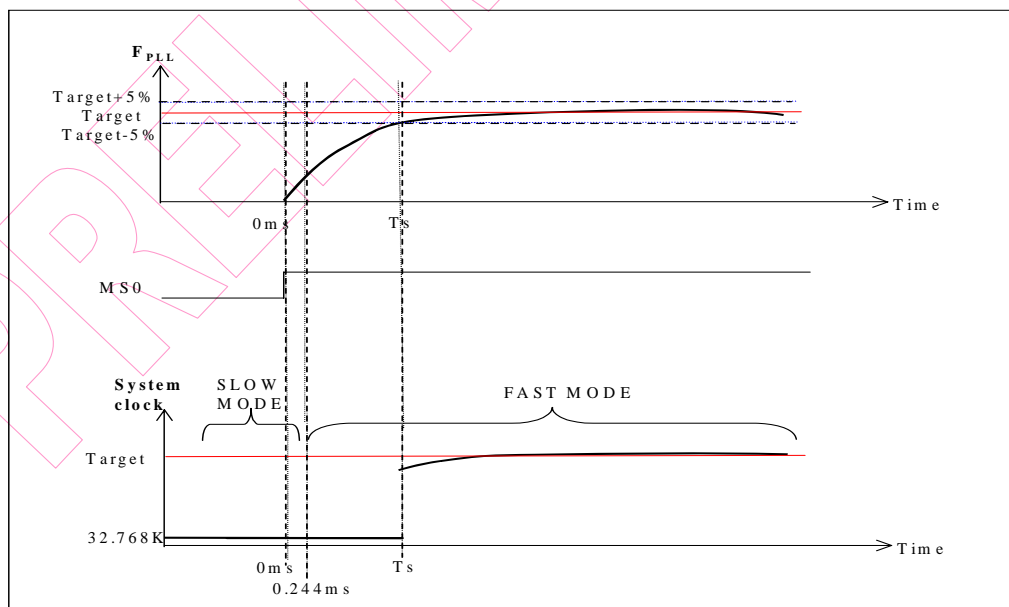

Figure 7-2 MCU Operation Timing Diagram

NOTE

1. Switch from Slow mode to Fast mode at Time=0ms
2. The System clock will switch to FPLL after 8 oscillation clocks, and the system clock will then increase to about hundreds of kHz.
3. The PLL frequency will be stable ($\pm 5\%$) at Time= T_s (2ms~5ms).

8 ROM and RAM

8.1 Program ROM Map

8K Words \times 8 Segments = 64K Words	
Address	Segment
0000h 000Bh	Interrupt Vector (12 words)
000Ch 0013h	Code Option (8 words)
0014h 001Fh	Test Program (12 words)
0020h 3FFFh	Segment 0 Segment 1
4000h 7FFFh	Segment 2 Segment 3
8000h BFFFh	Segment 4 Segment 5
C000h FFFFh	Segment 6 Segment 7

8.2 Data ROM Map

Maximum Size is 256K Words	
Address	Segment
100000h 13FFFFh	Data ROM (4M bits)

8.3 RAM Map

(RAM Size: 128 Bytes + 12 Banks × 128 Bytes = 1664 Bytes)

- Other Un-banked Register of RAM:

Address	Un-banked
00h 1Fh	Special Register
20h 55h	Control Register
56h 7Fh	General Purpose RAM

- Banked Register of RAM: (selected by BSR)

Address	Bank 0	Bank 1	Bank 2	Bank 3	Bank 11
80h FFh	General Purpose RAM	General Purpose RAM	General Purpose RAM	General Purpose RAM	General Purpose RAM

8.4 LCD RAM Map

LCD RAM	LCDARH [2:0]					
	101 (Page 05)	100 (Page 04)	011 (Page 03)	010 (Page 02)	001 (Page 01)	000 (Page 00)
Address	COM47~COM40	COM39~COM32	COM31~COM24	COM23~COM16	COM15~COM8	COM7~COM0
LCDARL	Bit 7 ~ Bit 0	Bit 7 ~ Bit 0	Bit 7 ~ Bit 0	Bit 7 ~ Bit 0	Bit 7 ~ Bit 0	Bit 7 ~ Bit 0
00H (SEG0)						
:						
3FH (SEG63)						
40H ~ 4FH	Not for Use					
50H (SEG80)						
:						
6FH (SEG111)						

Note: LCDARL = 40H ~4FH are not for use

9 Electrical Characteristics

9.1 Absolute Maximum Ratings

Items	Sym.	Condition	Limits	Unit
Supply voltage	VDD	-	-0.3 to +3.6	V
Input voltage (general input port)	VIN	-	-0.5 to VDD +0.5	V
Power Consumption (Topr=70°C)	PD	-	300	mW
Operating temperature range	TOPR	-	-10 to +70	°C
Storage temperature range	TSTR	-	-55 to +125	°C

9.2 Recommended Operating Conditions

Items	Sym.	Condition	Limits	Unit
Supply voltage	VDD	-	2.2 to 3.6	V
	AVDD		2.4 to 3.6	
Input voltage	VIH	-	VDD × 0.9 to VDD	V
	VIL	-	0 to VDD × 0.1	V
A/D Full-Scale input span	ADRG	Positive input-negative input	0 to VREX	V
Operating temperature	TOPR	-	-10 to +70	°C

9.3 DC Electrical Characteristics

Condition: Ta=-10~+70°C, VDD= 3.0 ± 0.3V

Parameter	Sym.	Condition	Min.	Typ.	Max.	Unit	
Clock	Fmain	Main-clock frequency	1	-	16	MHz	
	Fsub	Sub-clock frequency	RC OSC	24.6	32.8	41	kHz
Crystal OSC			-	32.768	-		
Supply Current	Idd1	Sleep mode	VDD = 3V, No load		1	μA	
	Idd2	Idle mode	VDD = 3V RC OSC, LCD disable		8		
	Idd3		VDD = 3V, Crystal OSC, LCD disable		5		
	Idd4	Idle mode	Normal current: VDD = 3V, Crystal / RC OSC, LCD enable, Vout = 2VDD, Code Option: V0 and V1~V4 OP On (No load)		80		100
			Small current: VDD = 3V, Crystal / RC OSC, LCD enable (Partial display mode, Vout = VDD) Code Option: V0 OP off (≤Vdd, external voltage), and V1~ V4 OP On (No load)		40		60
	Idd5	Slow mode	VDD = 3V, LCD disable, RC/Crystal OSC, No load		20		30
	Idd6	Fast mode	VDD = 3V, Fmain = 4 MHz, No load		1200		1600
VDD = 3V, Fmain = 10 MHz, No load			2200	2900			
Idd7	Fast mode	VDD = 3V, Fmain = 15 MHz, No load		3500	4800		
Input Voltage	VIH1	PA[0:7], PB[0:2,5:7], PC[2:7], PD[4:7], PG[0:7]	VDD×0.7	-	VDD	V	
	VIL1	PH[0:7] (as general input port)	0	-	VDD×0.3		
Input Threshold Voltage (Schmitt)	VT+	RSTB, PB.5 (as EVIN or CPIN), FR and CL (as input port);	0.5×VDD	-	0.75×VDD	V	
	VT-		0.2×VDD	-	0.4×VDD		

(Continuation)

Parameter	Sym.	Condition	Min.	Typ.	Max.	Unit
Output Current	IOH1	PB[7:6],PB[5],PB[1:0],PC[2:7], VDD = 3V, VOH = 2.4V	-1.1	-2.2	-3.3	mA
	IOL1	PD[7:4] (as general output port), CL and FR (as output pin) VDD = 3V, VOL = 0.2V	+1.1	+2.2	+3.3	
	IOH2	PB[1] (as D/A output) VDD = 3.0V, VOH = 0.7V	-2.5	-3.5	-4.5	
	IOH3	PB[1:0] (as PWM output) VDD = 3.0V, VOH = 1.5V	-200	-300	-400	
	IOL3		VDD = 3.0V, VOL = 1.5V	+200	+300	+400
	IOH5	PG[7:0]~PH[0:7] VDD = 3.0V, VOH = 2.4V	-1.6	-2.6	-3.6	mA
	IOL5		VDD = 3.0V, VOL = 0.2V	+1.1	+2.2	+3.3
	IOH6	PB[2] (as IR output pin) VDD = 3.0V, VOH = 2.1V	-5	-10	-15	mA
IOL6	VDD = 3.0V, VOL = 0.9V		+4	+8	+12	mA
Input Leakage Current	IIL	All Input port (without pull up/down resistor) Vin = VDD or GND	-	-	±1	µA
Large Pull-up resistance	RPU1	PA[6:0] Key high resistance, pulled up by R2, LCD enable (BOOST=1, normal display mode), Vin = GND, VDD = 3V	100	200	300	KΩ
	RPU3	PA[7], PB[0:2,5:7], PC[2:7], PD[4:7] Vin = GND, VDD = 3V	300	800	1300	
		PG[7:0]~PH[7:0] Vin = GND, VDD = 3V	50	150	250	
	RPU5	RSTB Vin = GND, VDD = 3V	250	500	750	
Small Pull up Resistance	RPU2	PA[6:0] Key low resistance, pulled up by R1//R2, LCD enable (BOOST=0, normal display), Vin = GND, VDD = 3V	10	25	40	KΩ
		Key low resistance, pulled up by R1//R2, LCD enable (BOOST=1, normal display), Vin = GND, VDD = 3V	15	30	45	
	RPU4	PA[7], PB[0:2,5:7], PC[2:7], PD[4:7], PG[0:7], PH[0:7] Vin = 2V, VDD = 3V	50	100	200	
	RPU6	RSTB Vin = 2V, VDD = 3V	50	100	200	
Large Pull down Resistance	RPD1	TEST Vin = VDD, VDD = 3V	250	500	750	KΩ
Small Pull down Resistance	RPD2	TEST Vin = 1V, VDD = 3V	1.1	2.2	3.3	KΩ
Touch Panel Pull down Resistance	RPD3	DET = 1, Xn pin Vin = VDD, VDD = 3V	25	50	100	KΩ
Data Retention Voltage	Vret	-	1.6	-	-	V
Power-on Reset Voltage	Vpor	-	1.4	1.5	1.6	V

(Continuation)

Parameter	Sym.	Condition	Min.	Typ.	Max.	Unit
A/D Conversion (VDD = 3.0V, AVDD = 3.0V, Ta = -10 ~ +70°C, Fclk = 12*Fsample)						
Analog Input						
Mux Leakage Current	Imux	On/off leakage current, Vin = 0 or VDD	-	0.1	1	μA
System Performance						
Resolution	-	-	-	10	-	Bit
Integral Non-Linearity	INL	-	-2	-	+2	LSB
Differential Non-Linearity	DNL	-	-2	-	+2	LSB
Offset Error	OErr	-	-4	-	+4	LSB
Gain Error	GErr	-	-4	-	+4	LSB
Missing Code	MC	-	No missing code			Bit
AVDD Supply Current	Ivdd3	AVDD = 3.0V, VDD = 3.0V, Fsample = 20kHz, ADEN = 1, VRS = 1	-	0.5	0.7	mA
	Ivdd4	ADEN = 0, VRS = 1	-	-	1	μA
Driver Current	IOH	Xp, Yp (VDD = 2.9 ± 0.3V) (Voh = VDD - 0.2V)	-20	-30	-45	mA
Sink Current	IOL	Xn, Yn (VDD = 2.9 ± 0.3V) (Vol = 0.2V)	+20	+30	+45	mA
Reference Voltage						
Internal Reference Voltage	VRIN	AVDD = 3.0 ± 0.3V	1.8	2.0	2.2	V
Internal Reference Supply Current	Ivrin	VDD = 3.0V, AVDD = 3.0V, VRS = 0, VOH = 0.2V	400	500	-	μA
VREX input current	Iref1	ADEN = 1, VRS = 1	-	300	500	μA
	Iref2	ADEN = 0, VRS = 1	-	-	1	μA
LCD Driver						
Reference Voltage	Vref1	Ta = 20°C ^{*1}	2.035	2.12	2.205	V
	Vref2	Ta = 0°C ^{*1}	2.169	2.26	2.351	V
	Vref3	Ta = 40°C ^{*1}	1.900	1.98	2.060	V
Charge Pump Output	Vout	2 times pumping. Capacitance of charge pump C1: 0.1μF	2*Vdd-5%	2*Vdd	-	V
		3 times pumping. Capacitance of charge pump C1 and C2: 0.1μF	3*Vx-5%	3*Vx	-	V
Clamping Voltage	Vx	BOOST = 0, 2 times pumping	-	Vdd	-	V
		BOOST = 1, 3 times pumping	2.3	2.4	2.5	V
Regulated Voltage	V0	VDD = 2.3V~3.3V, Ta = 25°C	V0-10%	V0 ^{*2}	V0+10%	V

(Continuation)

Parameter	Sym.	Condition	Min	Typ	Max	Unit	
LCD Display Output ON-Resistance	ROC	Com[0:31]	VOH = V0 ± 0.2V	1	2	3	KΩ
			VOM = V1 ± 0.2V				
			VOM = V4 ± 0.2V				
			VOL = 0.2V				
	ROS	Seg [0 : 63, 80:111]	VOH = V0 ± 0.2V	1	2	3	KΩ
			VOM = V2 ± 0.2V				
			VOM = V3 ± 0.2V				
			VOL = 0.2V				
Strobe Output ON-Resistance	ROP	Seg [0:15] (as key strobe)	V = VDD - 0.2V	45	70	100	KΩ
	RON		V = 0.2V	0.7	1.0	1.5	
Display Frame Frequency	Frame	Sub-Clock : RC OSC	48	-	100.5	Hz	
		Sub-Clock : Crystal OSC	64	-	80.4		
Op. Amp Voltage Output of LCD Power Supply	Vout0	V0	No load	- ^{*2}	V0 ^{*1}	- ^{*3}	mV
	Vout1	V1		- ^{*2}	V1 ^{*1}	- ^{*3}	
	Vout2	V2		- ^{*2}	V2 ^{*1}	- ^{*3}	
	Vout3	V3		- ^{*2}	V3 ^{*1}	- ^{*3}	
	Vout4	V4		- ^{*2}	V4 ^{*1}	- ^{*3}	

^{*1}: V0~V4 Theoretical value

^{*2}: The Target value of V0~V4, Vlcd is Theoretical value ± 50mV

Typically regulated voltage for V0 is chosen by software from the following table:

Bias	V0	V1	V2	V3	V4
1/3	V0	2/3 * V0	1/3 * V0	2/3 * V0	1/3 * V0
1/3.5		2.5/3.5 * V0	1.5/3.5 * V0	2/3.5 * V0	1/3.5 * V0
1/4		3/4 * V0	2/4 * V0	2/4 * V0	1/4 * V0
1/4.5		3.5/4.5 * V0	2.5/4.5 * V0	2/4.5 * V0	1/4.5 * V0
1/5		4/5 * V0	3/5 * V0	2/5 * V0	1/5 * V0
1/5.5		4.5/5.5 * V0	3.5/5.5 * V0	2/5.5 * V0	1/5.5 * V0
1/6		5/6 * V0	4/6 * V0	2/6 * V0	1/6 * V0
1/6.5		5.5/6.5 * V0	4.5/6.5 * V0	2/6.5 * V0	1/6.5 * V0

9.4 AC Electrical Characteristics

Condition: Ta=-10~+70°C, VDD= 3.0 ± 0.3V

Parameter	Sym.	Condition	Min	Typ	Max	Unit
Instruction Cycle Time	Tcycle	Fmain = 1 MHz	-	2 ^{*1}	-	μs
		Fmain = 4 MHz	-	0.5 ^{*1}	-	
		Fmain = 10 MHz	-	0.2 ^{*1}	-	
		Fmain = 15 MHz	-	0.13 ^{*1}	-	
A/D Conversion (VDD = 3.0V, AVDD = 3.0V, Ta = -10~+70°C)						
Throughput Rate		VDD = 3.0V, AVDD = 3.0V	-	-	80	ksps
		VDD = 2.4V, AVDD = 2.4V	-	-	60	
Power Supply Rejection Ratio	PSRR1+	Power noise: 1kHz, 100mV	37	40	-	dB
	PSRR1-	Power noise: 1kHz, 100mV	43	46	-	
Signal to Noise Ratio	SNR	-	51	54	-	dB

^{*1}: Instruction cycle time = 2 × System clock time

PRELIMINARY

10 Application Circuits

(1) ELAN Product

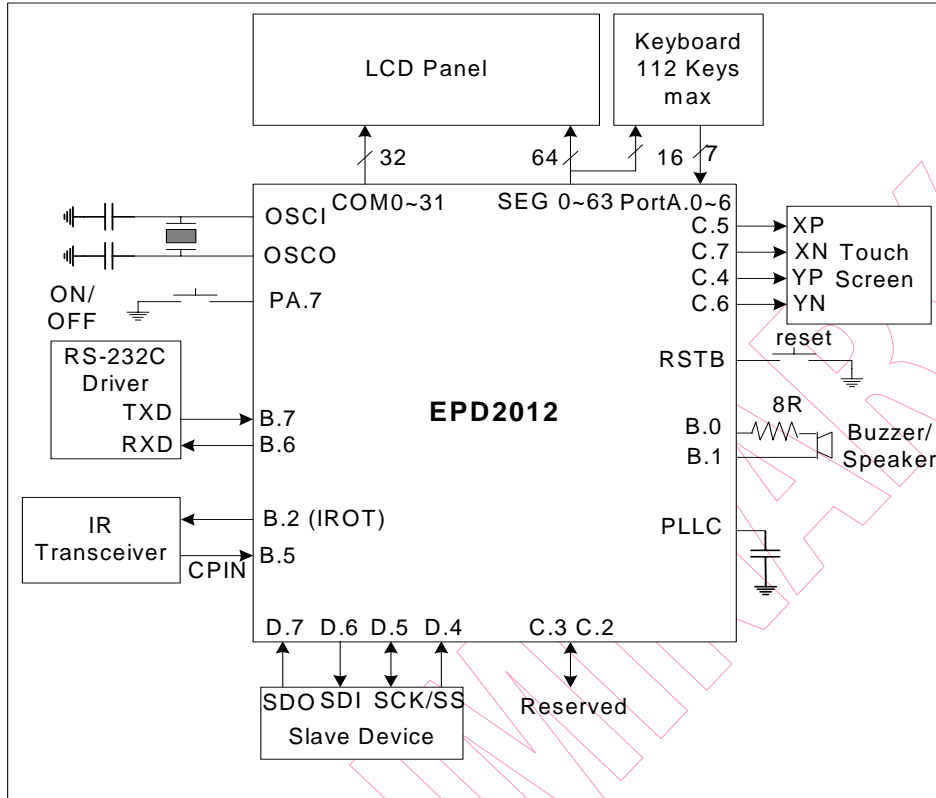

Figure 10-1 Application Circuits Diagram 1

(2) 32×64 pixels driving application circuits ("Single-chip" using internal oscillator)

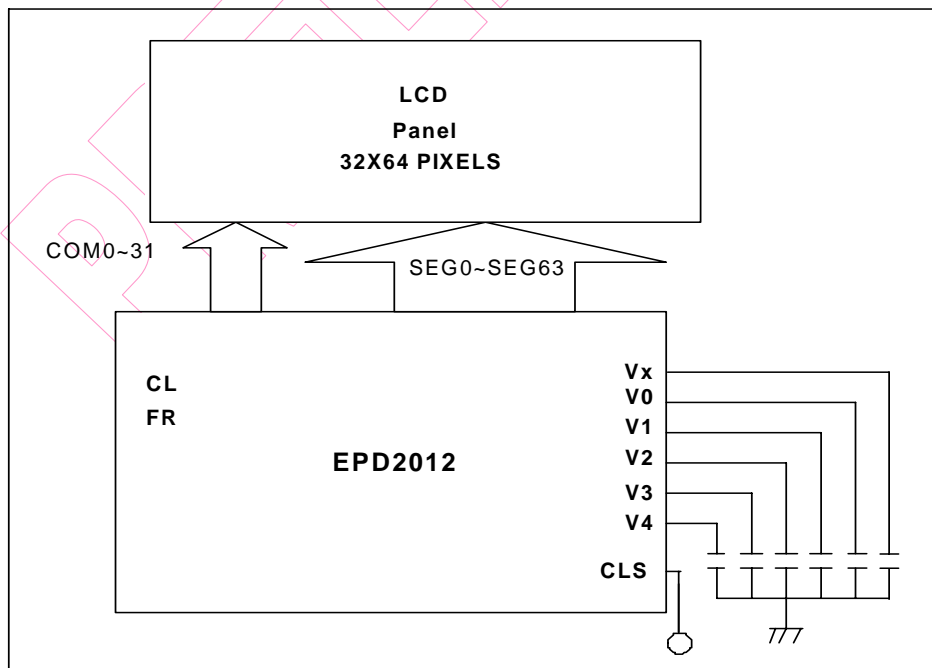

Figure 10-2 Application Circuits Diagram 2

(3) 48x96 pixels driving application circuits ("Multi-chip" using EM65168A)

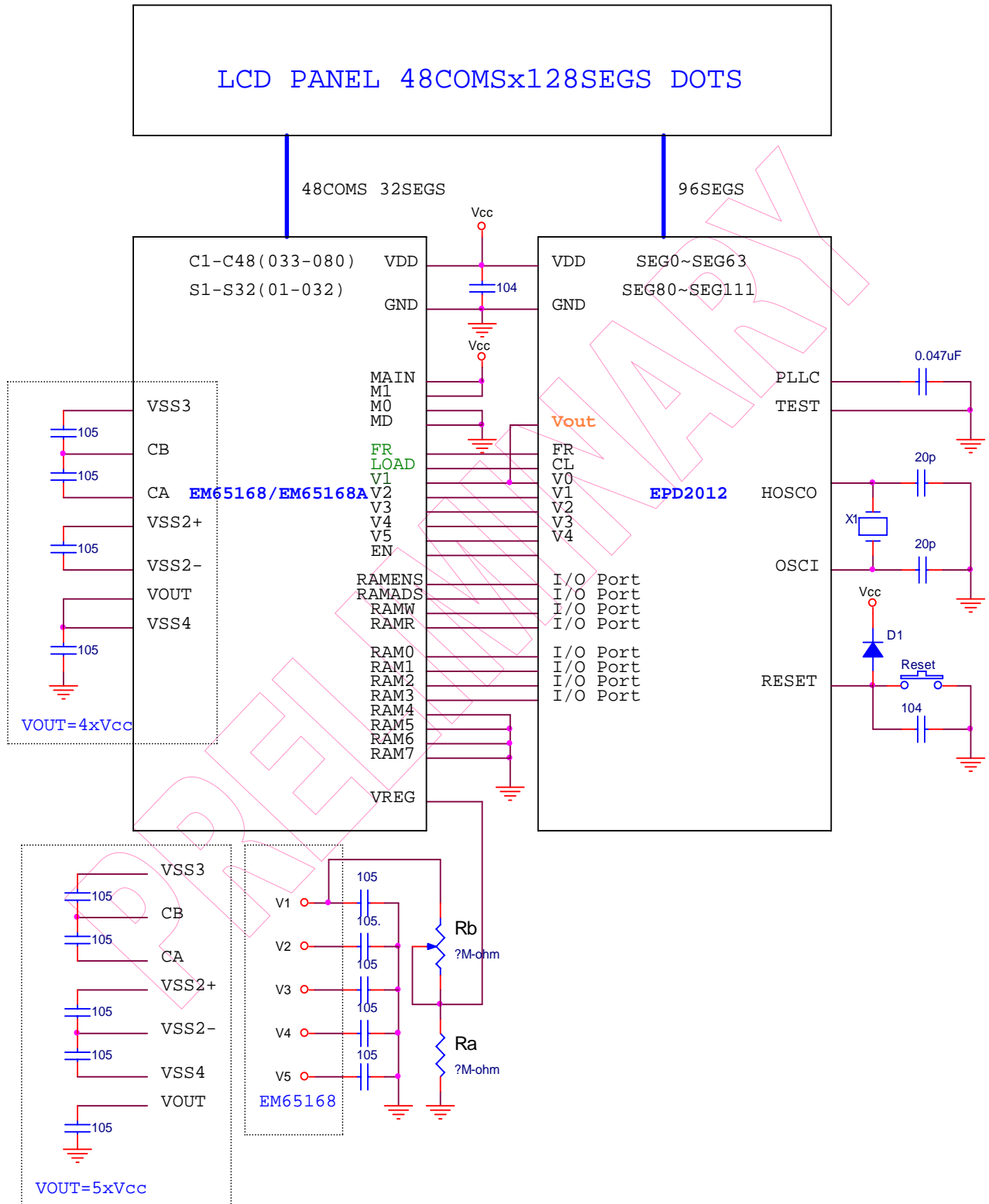

Figure 10-3 Application Circuits Diagram 3



PRELIMINARY