

---

# **EM34014A**

**10/12-DIGIT CALCULATOR**  
( BATTERY / SOLAR / DUAL POWER TYPE )

# **Product Specification**

**DOC. VERSION 1.0**

**ELAN MICROELECTRONICS CORP.**

April 2010

---



---

**Trademark Acknowledgments:**

IBM is a registered trademark and PS/2 is a trademark of IBM.

Windows is a trademark of Microsoft Corporation.

ELAN and ELAN logo  are trademarks of ELAN Microelectronics Corporation.

Copyright © 2002 ~ 2010 by ELAN Microelectronics Corporation

**All Rights Reserved**

Printed in Taiwan

The contents of this specification are subject to change without further notice. ELAN Microelectronics assumes no responsibility concerning the accuracy, adequacy, or completeness of this specification. ELAN Microelectronics makes no commitment to update, or to keep current the information and material contained in this specification. Such information and material may change to conform to each confirmed order.

In no event shall ELAN Microelectronics be made responsible for any claims attributed to errors, omissions, or other inaccuracies in the information or material contained in this specification. ELAN Microelectronics shall not be liable for direct, indirect, special incidental, or consequential damages arising from the use of such information or material.

The software (if any) described in this specification is furnished under a license or nondisclosure agreement, and may be used or copied only in accordance with the terms of such agreement.

ELAN Microelectronics products are not intended for use in life support appliances, devices, or systems. Use of ELAN Microelectronics product in such applications is not supported and is prohibited.

NO PART OF THIS SPECIFICATION MAY BE REPRODUCED OR TRANSMITTED IN ANY FORM OR BY ANY MEANS WITHOUT THE EXPRESSED WRITTEN PERMISSION OF ELAN MICROELECTRONICS.



---

**ELAN MICROELECTRONICS CORPORATION****Headquarters:**

No. 12, Innovation 1<sup>st</sup> Road  
Hsinchu Science Park  
Hsinchu, TAIWAN 30076  
Tel: +886 3 563-9977  
Fax: +886 3 563-9966  
[webmaster@emc.com.tw](mailto:webmaster@emc.com.tw)  
<http://www.emc.com.tw>

**Hong Kong:**

**Elan (HK) Microelectronics Corporation, Ltd.**  
Flat A, 19F., World Tech Centre 95  
How Ming Street, Kwun Tong  
Kowloon, HONG KONG  
Tel: +852 2723-3376  
Fax: +852 2723-7780

**USA:**

**Elan Information Technology Group (U.S.A.)**  
PO Box 601  
Cupertino, CA 95015  
U.S.A.  
Tel: +1 408 366-8225  
Fax: +1 408 366-8225

**Shenzhen:**

**Elan Microelectronics Shenzhen, Ltd.**  
3F, SSMEC Bldg., Gaoxin S. Ave. I  
Shenzhen Hi-tech Industrial Park  
(South Area), Shenzhen  
CHINA 518057  
Tel: +86 755 2601-0565  
Fax: +86 755 2601-0500  
[elan-sz@elanic.com.cn](mailto:elan-sz@elanic.com.cn)

**Shanghai:**

**Elan Microelectronics Shanghai, Ltd.**  
#34, First Fl., 2<sup>nd</sup> Bldg.,  
Lane 122, Chunxiao Rd.  
Zhangjiang Hi-Tech Park  
Shanghai, CHINA 201203  
Tel: +86 21 5080-3866  
Fax: +86 21 5080-4600  
[elan-sh@elanic.com.cn](mailto:elan-sh@elanic.com.cn)

---

# Contents

<b>1</b>	<b>General Description .....</b>	<b>1</b>
<b>2</b>	<b>Features .....</b>	<b>1</b>
<b>3</b>	<b>Pin Description .....</b>	<b>2</b>
<b>4</b>	<b>Functional Description.....</b>	<b>3</b>
4.1	Operational Characteristics .....	3
4.1.1	Constant Operation .....	3
4.1.2	Number Entry .....	3
4.1.3	Memory Protection .....	3
4.1.4	Memory Indication.....	3
4.1.5	Auto Power Off .....	3
4.2	Keyboard Description .....	3
4.3	Keyboard Definition .....	7
4.4	Error Conditions .....	8
4.4.1	Error Detection .....	8
4.4.2	Error Indication .....	8
4.4.3	Error Release.....	8
4.5	LCD Display .....	8
	LCD Segment.....	9
	LCD Segment.....	10
	LCD Segment.....	11
	LCD Segment.....	12
	LCD Segment.....	13
	LCD Segment.....	14
4.6	Display Waveforms.....	15
<b>5</b>	<b>Electrical Characteristics.....</b>	<b>23</b>
<b>6</b>	<b>Application Block Diagram .....</b>	<b>24</b>
	X .....	25
	Y .....	25
	X .....	26
	Y .....	26

## Specification Revision History

Doc. Version	Revision Description	Date
0.1	Initial version	2002/07/15
0.2	<ol style="list-style-type: none"> <li>1. Deleted the 'Automatic delta percentage' in the Features section.</li> <li>2. Modified the (CE/C/ON) key description.</li> <li>3. Modified the (GT+) key description.</li> <li>4. Added (000) key in decimal key.</li> <li>5. Modified (IC) key description.</li> <li>6. Modified the GT calculation.</li> </ol>	2002/07/22
0.3	<ol style="list-style-type: none"> <li>1. Modified the VIH &amp; VIL of K3~K14.</li> <li>2. Modified the VIH &amp; VIL of RESET.</li> <li>3. Added VEE specification.</li> <li>4. Modified ROH &amp; ROL (max) of the LCD pins.</li> <li>5. Modified the pull-up resistor of K0~K7 and RESET.</li> <li>6. Modified the pull-down resistor of K11~K14.</li> </ol>	2002/09/11
0.4	<ol style="list-style-type: none"> <li>1. Modified the operating voltage.</li> <li>2. Modified the supply current condition.</li> </ol>	2003/02/14
0.5	Modified the DC characteristics	2004/05/04
0.6	Modified the K12 select with TAX function	2005/03/03
0.7	Modified the DC spec. of IDDOP	2005/04/06
0.8	<ol style="list-style-type: none"> <li>1. Modified the switch column connection (Open, B3...)</li> <li>2. Modified the IC operating temperature (0 ~ 70°C)</li> </ol>	2006/01/03
0.9	Modified the Pad Diagram	2009/10/22
1.0	<a href="#">Upgraded to version 1.0</a>	<a href="#">2010/04/02</a>

---

## 1 General Description

The EM34014A is a single-chip LSI CMOS calculator for 12-digit, 2-memory or 10-digit 2-memory devices. The EM34014A can drive the liquid crystal display (LCD) with a single power supply. Single power supply operation, wide operating voltage and lower power consumption make it suitable for 1.5V solar battery operated calculator. Besides, the EM34014A can be selected to function in Auto Power-off or Manual Power-off with Switch Key. It can also be selected with Memory Hold or Clear at Power-off.

---

## 2 Features

- Display : 12-digit or 10-digit (selectable with a pin programmable) for data, 1-digit for sign, error, memory load symbol
- TAX function available (selectable with a pin programmable)
- Special LCD icons available (selectable with a pin programmable)
- Algebraic mode
- Standard four functions (addition, subtraction, multiplication, division)
- Memory and Grand total calculation
- Accumulating GT memory register with count up (or count down) item counter
- Automatic percentage operation with add-on discount
- Automatic mark-up and mark-down operations
- Square root
- Constant calculation
- Chain calculation
- Change sign
- Floating point (selectable with a switch)
- Fixed point ("0", "1", "2", "3", "4", or "6" selectable with a switch)
- Adding point mode (selectable with a switch)
- Rounding switch (rounding up, down and off)
- Trailing zero suppression
- Punctuation on display, commas for thousands
- Memory and GT memory contents indicator, turned with nonzero in the memory and GT memory

- Registration overflow, indicating too many digits are entered (the most significant digits are protected)
- Result overflow, indicated during calculation (most function keys are locked as it occurs)
- Memory overflow indication
- Complementary output buffer for direct driving of liquid crystal display
- On-chip oscillator/clock generator
- On-chip Keyboard encoding
- Automatic power-on clear
- Wide range supply voltage: 1.2V to 1.8V
- Very low power consumption
- Floating minus
- Key roll-over function (two keys)

### 3 Pin Description

Symbol	I/O	Function
COM1~3	O	LCD Common signal output
A1 ~ A3	O	LCD Segment signal output and strobe output for switch status
A4 ~ A13	O	LCD Segment signal output
B1 ~ B3	O	LCD Segment signal output and strobe output for switch status
B4 ~ B13	O	LCD Segment signal output
C1 ~ C2	O	LCD Segment signal output and strobe output for switch status
C3 ~ C13	O	LCD Segment signal output
VDD, VSS	–	Positive and negative power supply pin
VA, VB	–	Voltage doubler for LCD. Connect a 0.1μF capacitor between both pins.
VEE	–	LCD voltage from voltage doubler. Connect a 0.1μF capacitor to the VDD pin.
TS1	I	Test pin input, should be opened.
RESET	I	System reset / AC key input (built-in Schmitt Trigger for debouncing)
K0 ~ K2	O	Keyboard polling signal output pins
K3 ~ K7	I/O	Keyboard polling signal output and strobe input pins
K8 ~ K10	I	Keyboard strobe input pins
K11~K14	I	Switch status strobe input pins

## 4 Functional Description

### 4.1 Operational Characteristics

#### 4.1.1 Constant Operation

The EM34014A has an implied constant mode on +, −, ×, ÷, and % operations. The constant is performed automatically by the "=" key, "%" key, or "1/x" key without a constant for addition, subtraction and division while the first operand is the constant for multiplication.

#### 4.1.2 Number Entry

Numerals can be entered up to 12 digits.

#### 4.1.3 Memory Protection

In any error detection, the memory contents present before the error detection are protected.

#### 4.1.4 Memory Indication

If the memory contents are numbers other than zero, "M" is indicated in the sign-digit position.

#### 4.1.5 Auto Power Off

If no key is pressed for a specific period of time, the power supply will be automatically turned off (pin option). This time interval up to power-off is approximately 8 minutes.

### 4.2 Keyboard Description

#### Equal Key (=)

- Performs the keyed-in operation and maintains that operation for possible use
- Establishes power/reciprocation calculation

#### Multiplication Key (×)

- Pressing this key enters the multiplicand
- Performs the previous operation and displays the result

#### Division Key (÷)

- Pressing this key enters the dividend
- Performs the previous operation and displays the result



#### **Addition Key (+)**

- Pressing this key conditions the IC for an addition operation
- Performs the previous operation and displays the result

#### **Subtraction Key (-)**

- Pressing this key conditions the IC for a subtraction operation
- Performs the previous operation and displays the result

#### **Percent Key (%)**

The purpose of the percent key is to allow for calculation of add-on and discount. Determination of add-on requires the principal amount to be the first entry followed by the "+" or "x" key, with the percentage being the second entry. Pressing the percent key yields the amount to add on, such as TAX or interest. Pressing the "=" key adds this amount to the principal.

#### **Change Sign Key (+/-)**

Pressing the "+/-" key twice in succession causes the corresponding sign to appear and disappear. During a digital entry, this function changes the sign of the entered factor.

#### **Clear Key and Power-on Key (C & On)**

- Pressing the power-on key the first time displays the number "0".
- In the middle of a digital entry, pressing this key the second time will clear all the operating registers.

#### **Clear Entry/Clear Key (CE/C/On)**

- During a digital entry, pressing this key the first time will clear the entry register and displays the number "0".
- Pressing this key the second time will clear all registers.

#### **Clear Entry Key (CE)**

During a digital entry, pressing this key will clear the entry register and displays the number "0"

#### **Number, Decimal Key ("000", "00", "0 – 9", "•")**

The first number keyed in a sequence will clear the display and the pressed digit will be entered in the display. Successive entries will shift the display left and the keyed in data will be entered in the display register. The first decimal point entered is effective. An attempted entry of more than 12 digits or 11 decimal places will be ignored.

#### **Shift Key (→)**

Deletes the right most digit and the other digits will shift to the right.

#### **Memory Plus Key (M+)**

- Adds the current display to the memory contents.
- It will terminate a number entry.

#### **Memory Minus Key (M-)**

- Subtracts the current display from the memory contents.
- It will terminate a number entry.

#### **Memory Recall Key (RM)**

Transfers the contents of the memory register into the display register.

#### **Memory Clear Key (CM)**

Clears the memory contents

#### **Memory Recall and Clear Key (RCM)**

- First pressed of the RCM key, as the RM key, transfers the contents of the memory register into the display register.
- Second pressed of the RCM key, as CM key, clears the memory contents.

#### **Grand Total Plus Key (GT+)**

- Adds the current display to the contents of the grand total memory.
- It will terminate a number entry

#### **Grand Total Minus Key (GT-)**

- Subtracts the current display from the contents of the grand total memory.
- It will terminate a number entry

#### **GT Memory Recall and Clear Key (RCGT)**

- First pressed as RCGT key, transfers the contents of the GT memory register into the display register.
- Pressing the RCGT key the second time, clears the GT memory.

#### **Square Root Key ( $\sqrt{\quad}$ )**

Extracts the square root of a positive number displayed in the entry register.



### Exchange Key (EX)

Exchange two operands between the operators. For example, key in "a-b", and then key in "EX" will change "a-b" to "b-a".

### Item Counter Key (IC)

- Pressing the IC key the first time, recalls the value of the item counter.
- Pressing the IC key the second time, clears the GT memory.
- 0 ~ 99 count up / down by pressing the operator keys.
- The "+", "=", "M+" and "GT+" keys will increase it by one
- The "M-" and "GT-" keys will decrease it by one, "-" key will decrease it by two.
- The other operator keys and number keys will not change it.

### Mark-up Key (MU)

- Pressing [A][+][B][MU], executes  $100 \times (A + B) / B$
- Pressing [A][-][B][MU], executes  $100 \times (A - B) / B$
- Pressing [A][×][B][MU], executes  $A \times (1 + (B / 100))$
- Pressing [A][÷][+/-][B][MU][MU], executes  $A / (1 - (B / 100))$  and
- $| ( A / (1 - (B / 100)) ) - A |$

### TAX Rate Set and Recall Key (Rate)

- Pressing [RATE][TAX+], stores the displayed number into the TAX memory
- Pressing [RATE][TAX-], transfers the contents of the TAX memory register into the display register.

### Included TAX Key (TAX+)

Execute TAX-including calculation of the displayed number. The TAX rate is in the TAX memory.

### Excluded TAX Key (TAX-)

Execute TAX-excluding calculation of the displayed number. The TAX rate is in the TAX memory.

### 4.3 Keyboard Definition

#### ■ Keyboard Arrangement

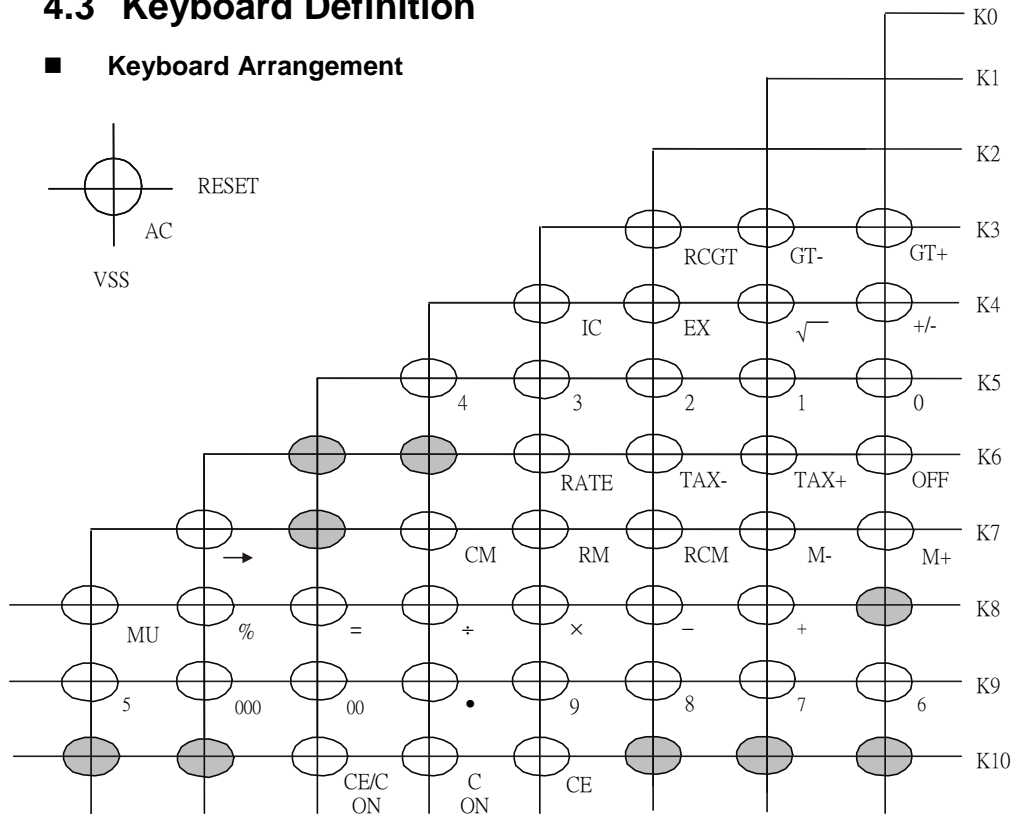

#### ■ Switch Connection

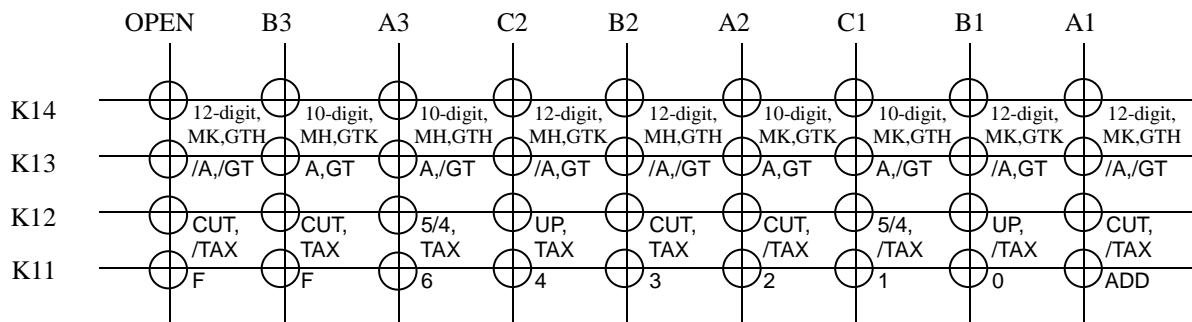

**K14 :** Select with Calculated Digits (12-digit or 10-digit) and Memory Hold Status, MH (Memory Hold), MK (Memory Kill), GTH (GT Memory Hold) and GTX (GT Memory Kill) at Auto Power-off or OFF key

**K13 :** Select with Auto Power OFF mode (A) and Grand total function (GT).

**K12 :** Select with Rounding switches (CUT, UP, 5/4), TAX function (TAX) and LCD icons.

LCD icons of /TAX option (the same as EM34014) : M, – (sign), E, GT

LCD icons of TAX option: (M, –(sign), E), (GT/=, +, –,  $\times$ ,  $\div$ ), (TAX+, TAX–, TAX%, RATE)

**K11 :** Select with Fixed point or floating mode.

## 4.4 Error Conditions

### 4.4.1 Error Detection

A system error occurs when:

- The integral part of any calculation result exceeds 12 digits.
- The integral part of any memory calculation result exceeds 12 digits or when the integral part of any addend or subtrahend to memory exceeds 12 digits.
- The integral part of a mark-up and mark-down calculation result exceeds 12 digits.
- A division by zero is attempted.
- An extraction of the square root of a negative number is attempted.

### 4.4.2 Error Indication

System Error:

- "0" is indicated in the first-digit position and "E" in the sign-digit position.
- The high-order 12-digit of a calculation result is indicated together with "E". The location of the decimal point corresponds to the result of calculation times  $10^{-12}$ , and no zero shift is performed.

### 4.4.3 Error Release

System Error:

A system error can be released by depressing the ON/AC key or CE/C key. However, the calculation result is not cleared by the CE/C key but is retained.

## 4.5 LCD Display

The device can directly drive an liquid crystal display (LCD) with 39 segment pins and 3 common pins. The drive method is 1/2 bias and 1/3 duty, built-in BCD to 7-segment decoder for 3V LCD.

The following table exhibits the relationship between the LCD segment, and common pins and the corresponding pattern on the display.

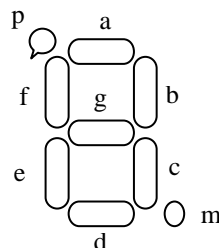

- LCD table for 10D calculator (the same as EM34014-10D calculator)

K14 select with "10D" and K12 select with "/TAX".

Segment		13	12	11	10	9	8	7	6	5	4	3	2	1
COM 1	An	M			b10	b9	b8	b7	b6	b5	b4	b3	b2	b1
	Bn				a10	a9	a8	a7	a6	a5	a4	a3	a2	a1
	Cn				f10	f9	f8	f7	f6	f5	f4	f3	f2	f1
COM 2	An	-(sign)			c10	c9	c8	c7	c6	c5	c4	c3	c2	c1
	Bn				g10	g9	g8	g7	g6	g5	g4	g3	g2	g1
	Cn				e10	e9	e8	e7	e6	e5	e4	e3	e2	e1
COM 3	An	E			m10	m9	m8	m7	m6	m5	m4	m3	m2	m1
	Bn				d10	d9	d8	d7	d6	d5	d4	d3	d2	d1
	Cn				GT	p9	p8	p7	p6	p5	p4	p3		

### LCD Segment

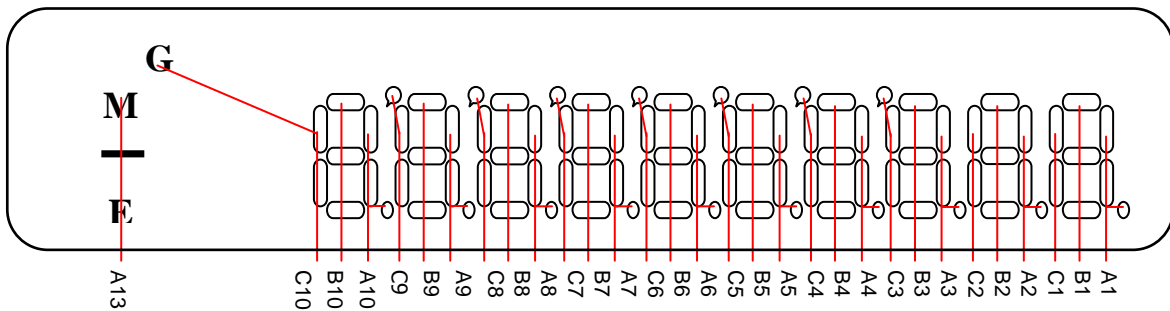

### LCD Common

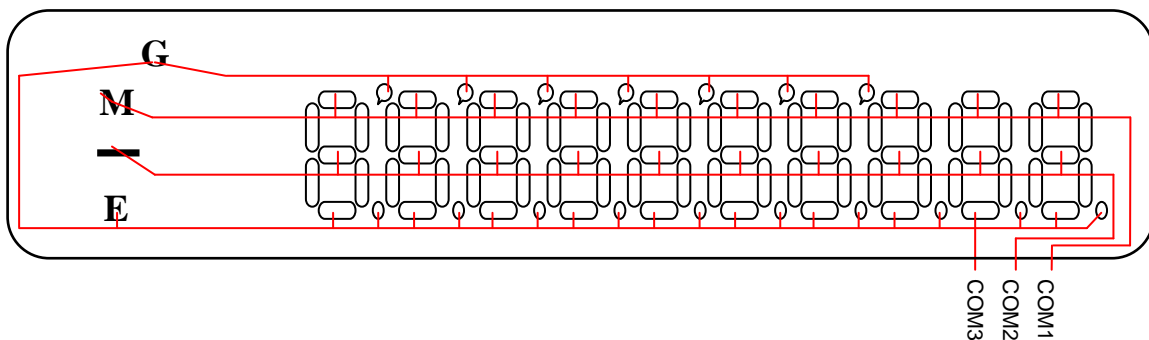

- LCD table for 12D calculator (same as EM34014-12D calculator)

K14 select with "12D" and K12 select with "/TAX".

Segment		13	12	11	10	9	8	7	6	5	4	3	2	1
COM 1	An	M	b12	b11	b10	b9	b8	b7	b6	b5	b4	b3	b2	b1
	Bn		a12	a11	a10	a9	a8	a7	a6	a5	a4	a3	a2	a1
	Cn		f12	f11	f10	f9	f8	f7	f6	f5	f4	f3	f2	f1
COM 2	An	-(sign)	c12	c11	c10	c9	c8	c7	c6	c5	c4	c3	c2	c1
	Bn		g12	g11	g10	g9	g8	g7	g6	g5	g4	g3	g2	g1
	Cn		e12	e11	e10	e9	e8	e7	e6	e5	e4	e3	e2	e1
COM 3	An	E	m12	m11	m10	m9	m8	m7	m6	m5	m4	m3	m2	m1
	Bn		d12	d11	d10	d9	d8	d7	d6	d5	d4	d3	d2	d1
	Cn		GT	p11	p10	p9	p8	p7	p6	p5	p4	p3		

**LCD Segment**

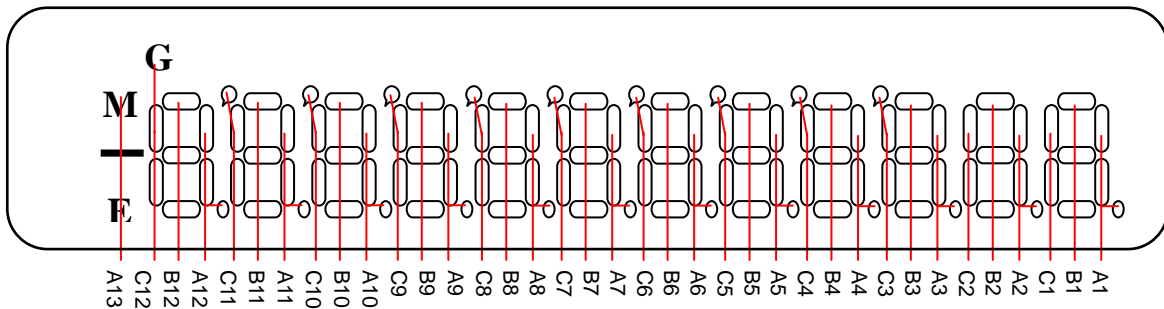

**LCD Common**

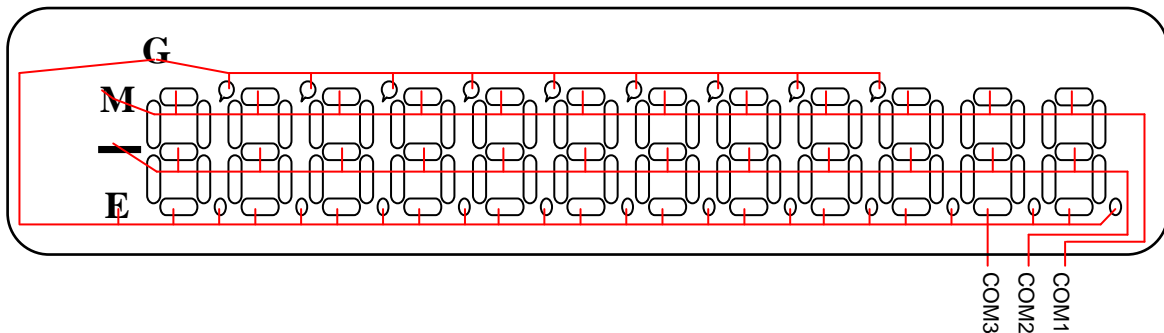

■ LCD table for 10D calculator with TAX function

K14 select with "10D", K13 select with "/GT" and K12 select with "TAX".

Segment	13	12	11	10	9	8	7	6	5	4	3	2	1
COM 1	An	M		b10	b9	b8	b7	b6	b5	b4	b3	b2	b1
	Bn	-		a10	a9	a8	a7	a6	a5	a4	a3	a2	a1
	Cn	×		f10	f9	f8	f7	f6	f5	f4	f3	f2	f1
COM 2	An	-(sign)		c10	c9	c8	c7	c6	c5	c4	c3	c2	c1
	Bn	+		g10	g9	g8	g7	g6	g5	g4	g3	g2	g1
	Cn	÷		e10	e9	e8	e7	e6	e5	e4	e3	e2	e1
COM 3	An	E		m10	m9	m8	m7	m6	m5	m4	m3	m2	m1
	Bn	TAX		d10	d9	d8	d7	d6	d5	d4	d3	d2	d1
	Cn	RATE		=	p9	p8	p7	p6	p5	p4	p3	TAX+	TAX-

**LCD Segment**

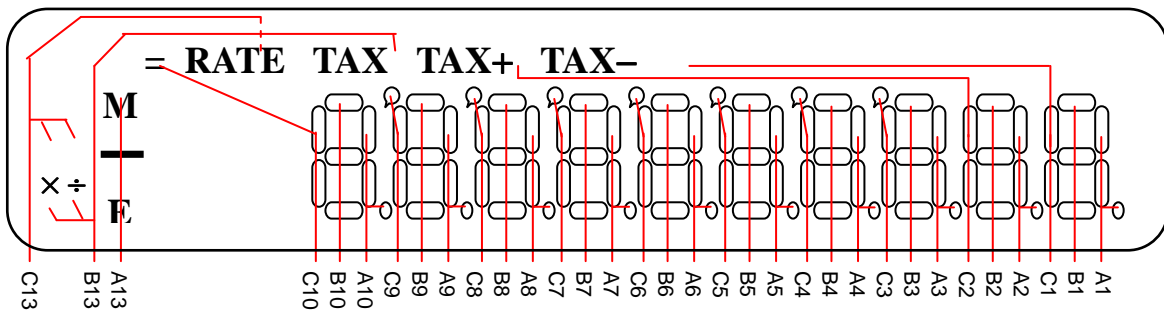

**LCD Common**

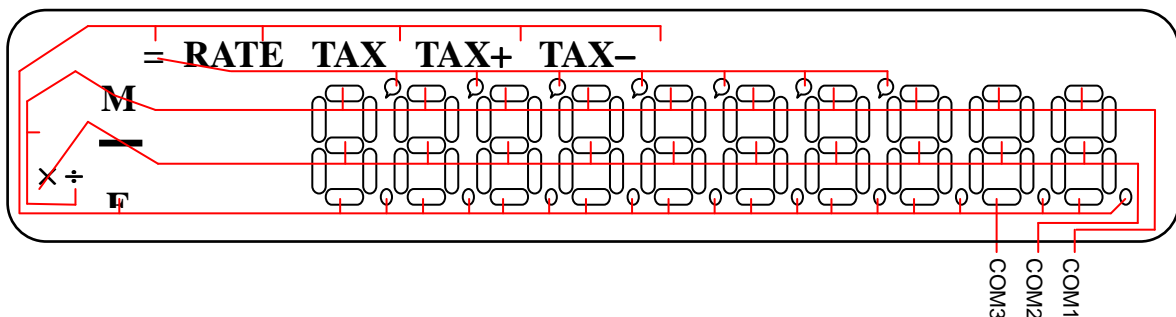

- LCD table for 12D calculator with TAX function

K14 select with "12D", K13 select with "/GT" and K12 select with "TAX".

Segment	13	12	11	10	9	8	7	6	5	4	3	2	1	
COM 1	An	M	b12	b11	b10	b9	b8	b7	b6	b5	b4	b3	b2	b1
	Bn	-	a12	a11	a10	a9	a8	a7	a6	a5	a4	a3	a2	a1
	Cn	×	f12	f11	f10	f9	f8	f7	f6	f5	f4	f3	f2	f1
COM 2	An	-(sign)	c12	c11	c10	c9	c8	c7	c6	c5	c4	c3	c2	c1
	Bn	+	g12	g11	g10	g9	g8	g7	g6	g5	g4	g3	g2	g1
	Cn	÷	e12	e11	e10	e9	e8	e7	e6	e5	e4	e3	e2	e1
COM 3	An	E	m12	m11	m10	m9	m8	m7	m6	m5	m4	m3	m2	m1
	Bn	TAX	d12	d11	d10	d9	d8	d7	d6	d5	d4	d3	d2	d1
	Cn	RATE	=	p11	p10	p9	p8	p7	p6	p5	p4	p3	TAX+	TAX-

### LCD Segment

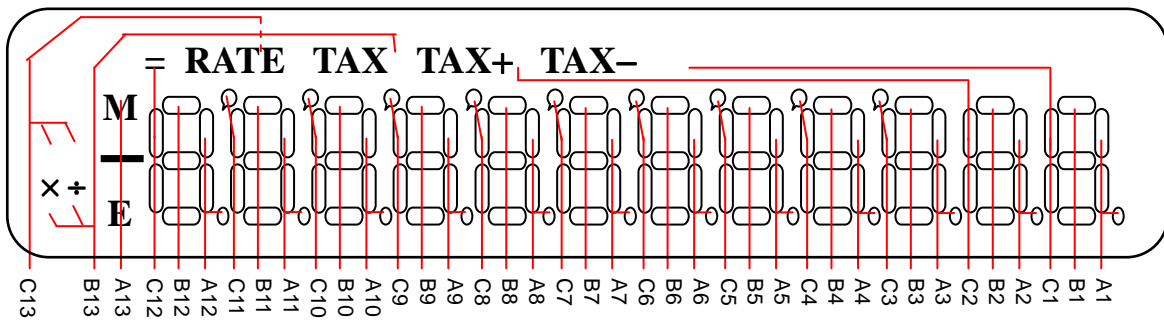

### LCD Common

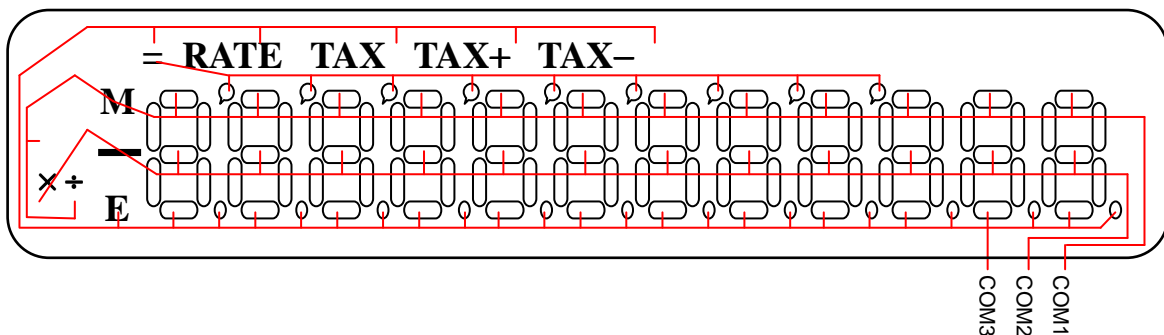

- LCD table for 10D calculator with TAX and GT function

K14 select with "10D", K13 select with "GT" and K12 select with "TAX".

Segment	13	12	11	10	9	8	7	6	5	4	3	2	1
C O M 1	An	M		b10	b9	b8	b7	b6	b5	b4	b3	b2	b1
	Bn	-		a10	a9	a8	a7	a6	a5	a4	a3	a2	a1
	Cn	×		f10	f9	f8	f7	f6	f5	f4	f3	f2	f1
C O M 2	An	-(sign)		c10	c9	c8	c7	c6	c5	c4	c3	c2	c1
	Bn	+		g10	g9	g8	g7	g6	g5	g4	g3	g2	g1
	Cn	÷		e10	e9	e8	e7	e6	e5	e4	e3	e2	e1
C O M 3	An	E		m10	m9	m8	m7	m6	m5	m4	m3	m2	m1
	Bn	TAX		d10	d9	d8	d7	d6	d5	d4	d3	d2	d1
	Cn	RATE		GT	p9	p8	p7	p6	p5	p4	p3	TAX+	TAX-

**LCD Segment**

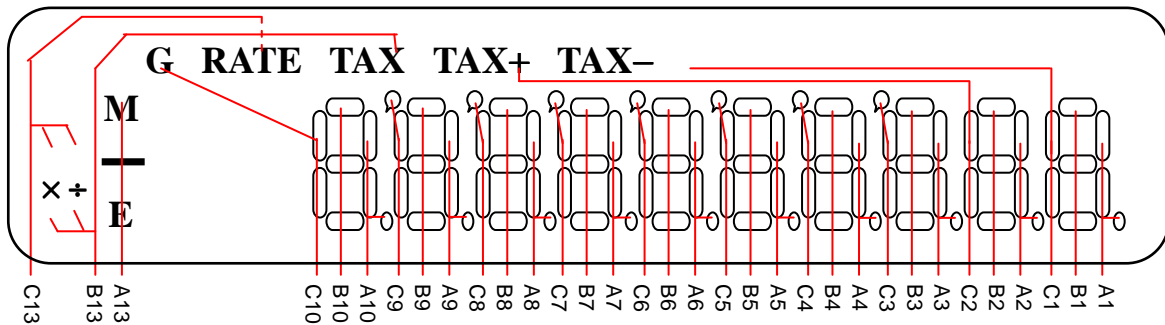

**LCD Common**

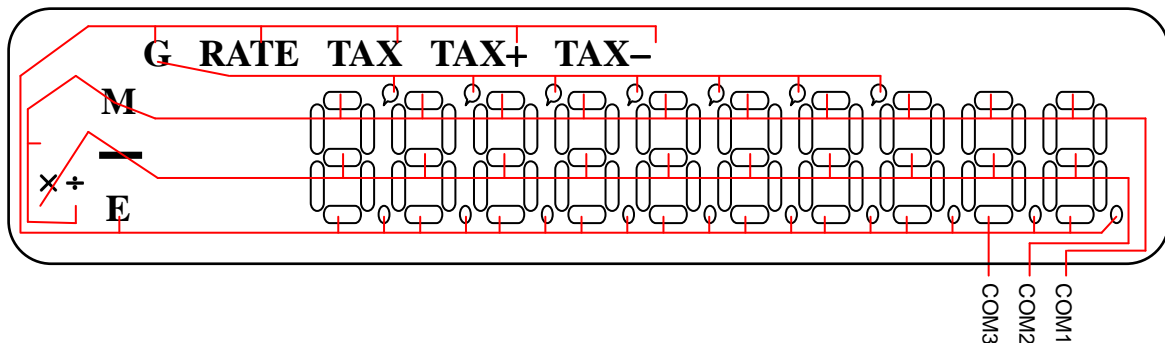

- LCD table for 12D calculator with TAX and GT function

K14 select with "12D", K13 select with "GT" and K12 select with "TAX".

Segment	13	12	11	10	9	8	7	6	5	4	3	2	1	
COM 1	An	M	b12	b11	b10	b9	b8	b7	b6	b5	b4	b3	b2	b1
	Bn	-	a12	a11	a10	a9	a8	a7	a6	a5	a4	a3	a2	a1
	Cn	×	f12	f11	f10	f9	f8	f7	f6	f5	f4	f3	f2	f1
COM 2	An	-(sign)	c12	c11	c10	c9	c8	c7	c6	c5	c4	c3	c2	c1
	Bn	+	g12	g11	g10	g9	g8	g7	g6	g5	g4	g3	g2	g1
	Cn	÷	e12	e11	e10	e9	e8	e7	e6	e5	e4	e3	e2	e1
COM 3	An	E	m12	m11	m10	m9	m8	m7	m6	m5	m4	m3	m2	m1
	Bn	TAX	d12	d11	d10	d9	d8	d7	d6	d5	d4	d3	d2	d1
	Cn	RATE	GT	p11	p10	p9	p8	p7	p6	p5	p4	p3	TAX+	TAX-

LCD Segment

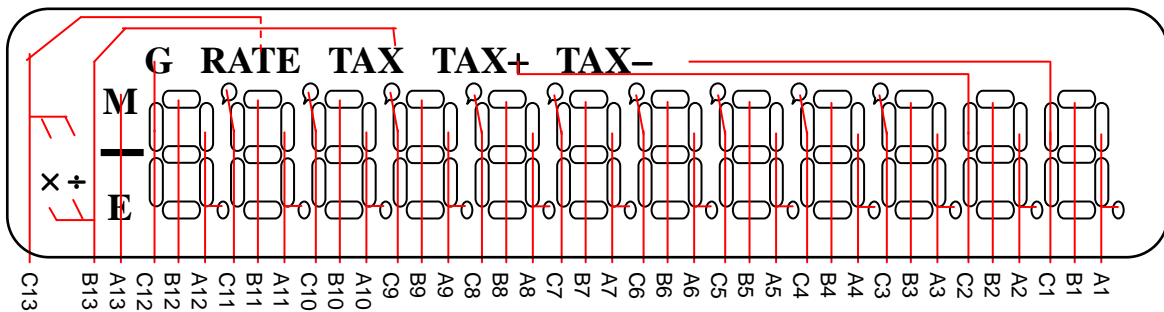

LCD Common

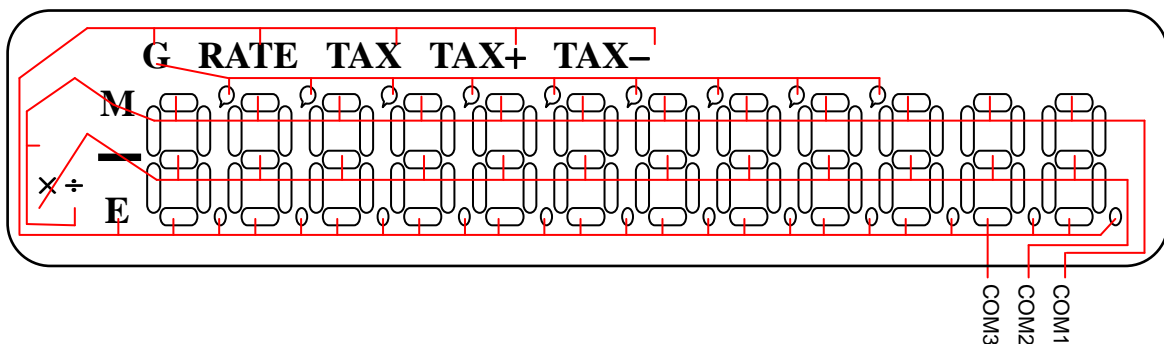

## 4.6 Display Waveforms

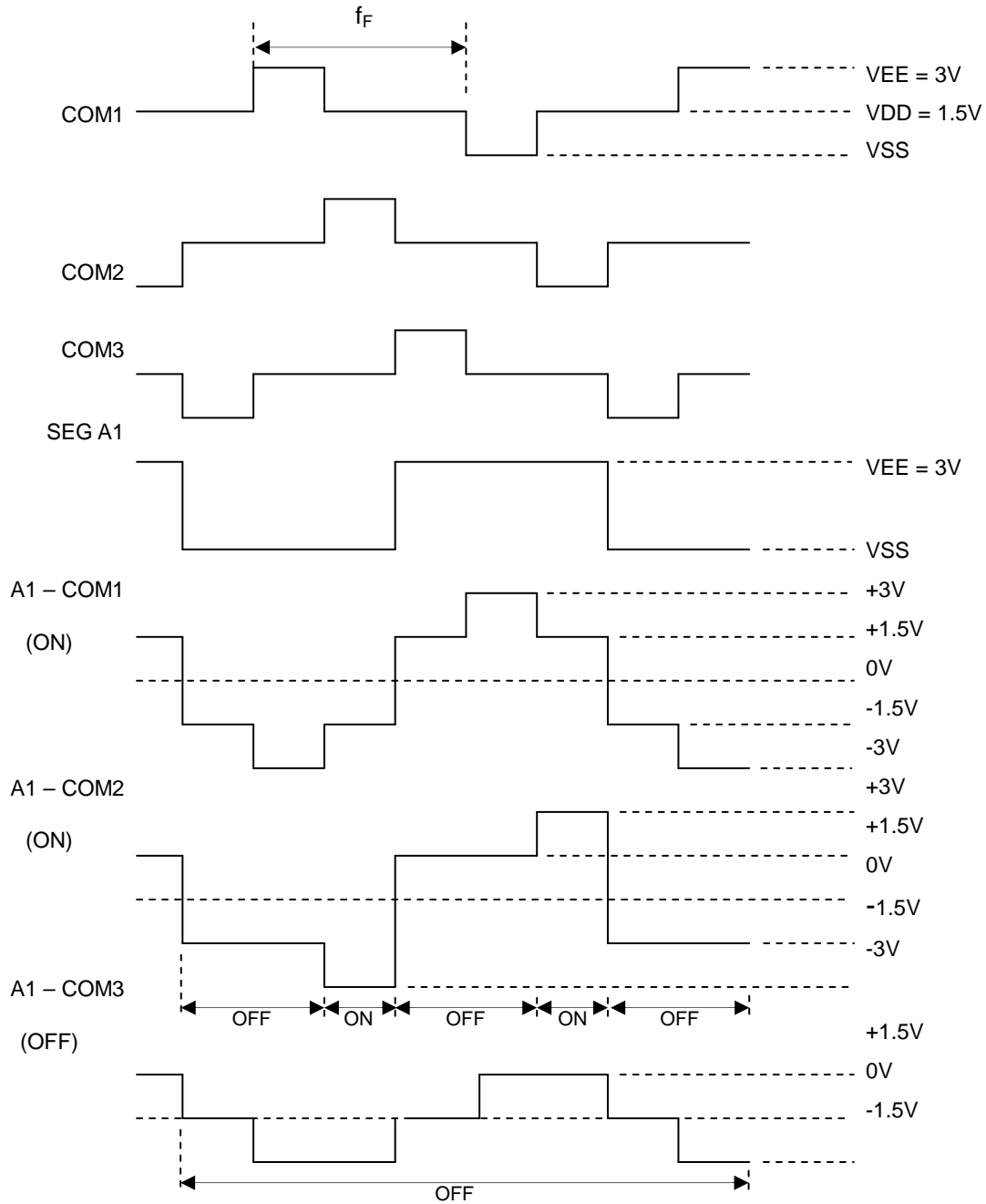



### Operation Examples

Type of Calculation	Operation	Key-in	Display	
Addition and Subtraction Calculation	TAB SW: 2, GT SW: Off, Round SW: 5/4, /TAX			
	100 + 200 = 300	C 100 + 200 =	0. 100. 300.00	
	3 - 5 = -2	C 3 - 5 =	0. 3. -2.00	
	10 + 20 - 50 = -20	C 10 + 20 - 50 =	0. 10. 30. -20.00	
	TAB SW: 2, GT SW: Off, Round SW: 5/4, TAX			
	10 + 20 - 50 = -20	C 10 + + 20 - - 50 = =	0. 10. 30. -20.00	
	Multiplication and Division Calculation	TAB SW: 2, GT SW: Off, Round SW: 5/4, /TAX		
		$(-2) \times 3$ = -6	C 1. 2 +/- × 3 = 2. - 2 × 3 =	0. -2. -6.00 -2. -6.00
$(-365) \div 7$ = -52.14		C 1. 365 +/- ÷ 7 = 2. - 365 ÷ 7 =	0. -365. -52.14 -365. -52.14	
$300 \times 2,145$ = 643,500 $300 \times 4,950.6$ = 1,485,180		C 300 × 2145 = 4950.6 =	0. 300. 643,500.00 1,485,180.00	
$31,750 \div 500$ = 63.50 $54,236 \div 500$ = 108.47		C 31750 ÷ 500 = 54236 =	0. 31,750. 63.50 108.47	
TAB SW: 2, GT SW: Off, Round SW: 5/4, TAX				
$(-2) \times 3 \div 4$ = -1.5		C 2 +/- × > 3 ÷ ÷ 4 = =	0. -2. -6. -1.50	



Type of Calculation	Operation	Key-in	Display
Square and Cube Calculation	TAB SW: 2, GT SW: Off, Round SW: 5/4, /TAX		
	$3^2$ = 9	C 3 × =	0. 3. 9.00
	$5^3$ = 125	C 5 × = =	0. 5. 25.00 125.00
Reciprocal Calculation	TAB SW: 2, GT SW: Off, Round SW: 5/4, /TAX		
	$1 \div 4$ = 0.25	1. 1 ÷ 4 =	0. 1. 0.25
		2. 4 ÷ =	4. 0.25
Percentage Calculation	TAB SW: 2, GT SW: Off, Round SW: 5/4, /TAX		
	$2,350 \times 17 \%$ = 399.50	C 2350 × 17 %	0. 2,350. 399.50
	$456 \div 789 \%$ = 57.79	C 456 ÷ 789 %	0. 456. 57.79
	$2,000 + (2,000 \times 12 \%)$ = 2,240	C 2000 × 12 % + =	0. 2,000. 240.00 240.00 2,240.00
	$2,000 - (2,000 \times 12 \%)$ = 1,760	C 2000 × 12 % - =	0. 2,000. 240.00 240.00 1,760.00
	TAB SW: 2, GT SW: Off, Round SW: 5/4, TAX		
	$2,350 \times 17 \%$ = 399.50	C 2350 × 17 % × =	0. 2,350. 399.50
"→" key	TAB SW: 2, GT SW: Off, Round SW: 5/4, /TAX		
		C 122.5 → 3 → → 345 + 0.678 = → → × 10 % →	0. 122.5 122. 122.3 122. 12. 12,345. 12,345.68 12,345.6 12,345.6 1,234.56 1,234.5



Type of Calculation	Operation	Key-in	Display
Reverse (EX)	TAB SW: 2, GT SW: Off, Round SW: 5/4, /TAX		
	$3 \div (1 + 2 + 3 + 4) = 0.3$	C 1 + 2 + 3 + 4 + ÷ 3 EX =	0. 1. 3. 6. 10. 10. 3. 10. 0.30
Square Root Calculation	TAB SW: 2, GT SW: Off, Round SW: 5/4, /TAX		
	$25^{1/2} = 5$	C 25 √ =	0. 25. 5. 5.00
Clear Entry (CE)	TAB SW: 2, GT SW: Off, Round SW: 5/4, /TAX		
		C 123 × 756 CE 456 =	0. 123. 756. 0. 56,088.00
ADD Mode For Addition and Subtraction	TAB SW: ADD, GT SW : Off, Round SW: 5/4, /TAX		
	$12.55 + 15.75 + 4.20 + 100.00 - 10.45 - 5.30 = 116.75$	C 1255 + 1575 + 420 + 100. - 1045 - 530 =	0. 12.55 28.3 32.5 132.5 122.05 116.75
For Calculations that are Not Addition or Subtraction	$12 \times 20 = 240$ $200 \div 3 = 66.67$	C 12 × 20 = 200 ÷ 3 =	0. 12. 240.00 200 66.67
Store Memory Calculation	TAB SW: 3, GT SW: Off, Round SW: CUT, /TAX		
	1,000 M+ 100,000,000,000 M- 100 × 3 M+ 1500 ÷ 2 M- M = -99,999,999,999,450	C 1000 M+ 100000000000 M- 100 × 3 M+ 1500 ÷ 2 M- RM CM	M M M M M M M M



Type of Calculation	Operation	Key-in		Display
cont. Store Memory Calculation	100,000,000,000 M- 100,000,000,000 M+ 400 × 2 M- 300 ÷ 5 M+ M = -740	100000000000 M- 100000000000 M+ 400 × 2 M- 300 ÷ 5 M+ RCM RCM	M   M M M M	0. 100,000,000,000. 100,000,000,000. 400. 800.000 300. 60.000 -740 -740
	TAB SW: 3, GT SW: Off, Round SW: CUT, TAX			
	1,000 M+ 100,000,000,000 M- 100 × 3 M+ 1500 ÷ 2 M- M = -99,999,999,999,450	1000 M+ 100000000000 M- 100 × 3 M+ 1500 ÷ 2 M- RM CM	M = M = M × M = M = M ÷ M = M M	0. 1,000.000 100,000,000,000. 100. 300.000 1,500. 750.000 -99,999,999,999,450 -99,999,999,999,450
GT Calculation	TAB SW: 3, GT SW: On, Round SW: CUT, /TAX			
	10 + 20 = 30  200 × 20% = 40  2 × 3 = 6  -200,000,000,000 = -200,000,000,000  960 + 4 = 964  GT = -199,999,998,960	10 + 20 =  200 × 20 %  2 × 3 =  200000000000 +/- =  960 + 4 =  GT GT	C          G G G G  G G  G G  G G	0. 10. 30.000  200. 40.000  2. 6.000  -200,000,000,000. -400,000,000,000.  960. 964.000  -399,999,998,960. -399,999,998,960.
	TAB SW: 3, GT SW: On, Round SW: CUT, TAX			
	10 + 20 = 30  200 × 20% = 40  2 ÷ 3 = 0.666	10 + 20 =  200 × 20 %  2 ÷ 3 =	C       + G  × G G  ÷ G G	0. 10. 30.000  200. 40.000  2. 0.666





Type of Calculation	Operation	Key-in	Display		
Overflow	TAB SW: 2, GT SW: Off, Round SW: CUT, TAX				
Addition and Subtraction Calculation	- 600,000,000,000 - 600,000,000,000 = - 1,200,000,000,000 E	600000000000 +/- - 600000000000 =	0. -600,000,000,000. -600,000,000,000. -1.2000000000 -1.200000000000		
	400,000,000,000 + 400,000,000,000 - 400,000,000,000 - 400,000,000,000 + 400,000,000,000 + 400,000,000,000 = 1,200,000,000,000 E	400000000000 + 400000000000 - 400000000000 - 400000000000 + 400000000000 + 400000000000 + 400000000000 =	C/CE C/CE + - - + + + + + + = E	0. 0. 0. 400,000,000,000. 800,000,000,000. 400,000,000,000. 0. 400,000,000,000. 800,000,000,000. 1.2000000000 1.200000000000	
	100,000,000,000 × 200 = 20,000,000,000,000 E	100000000000 × 200 =	C × = E	0. 100,000,000,000. 20.0000000000	
	123,000,000,000 ÷ 0.001 = 123,000,000,000,000 E	123000000000 ÷ 0.001 =	C ÷ = E	0. 123,000,000,000. 123.0000000000 0.	
	1 ÷ 0 = 0. E	1 ÷ 0 =	C ÷ = E	0. 1. 0.	
	Store (M, MII & GT) Memory Calculation	800,000,000,000 M+ M+ E M = 800,000,000,000	800000000000 M+ M+ C RM CM	0. 800,000,000,000. 1.6000000000 0. 800,000,000,000. 800,000,000,000.	
		TAB SW: 2, GT SW: On, Round SW: CUT, TAX			
		900,000,000,000 = 900,000,000,000 = E	900000000000 = 900000000000 =	G E G	900,000,000,000. 1.8000000000
			C GT GT	G G	0. 900,000,000,000. 900,000,000,000.



Type of Calculation	Operation	Key-in	Display
TAX Calculation	TAB SW: 2, GT SW: Off,	Round SW: UP	
TAX Rate Setting	TAX rate: 5%	C RATE 5 TAX+	0. 0. 5.
		C 5 RATE TAX+	0. 5. 5.
TAX Rate Recall	TAX rate: 5%	C RATE TAX-	0. 0. 5.
TAX+ Calculation	TAX rate: 5%	C 800 TAX+	0. 800. 840.00
		TAX+ TAX+ TAX+	AX 40.00 840.00
TAX- Calculation	TAX rate: 5%	C 840 TAX-	0. 840. 800.00
		TAX- TAX- TAX-	TAX- TAX 40.00 800.00
Calculation Including TAX+ Values	TAX rate: 20%	C 100 + 1000 TAX+	0. 100. 1,200.00
		+ 2000 TAX+ TAX+ =	+ + TAX+ + + TAX+ + TAX =
Calculation Including TAX- Values	TAX rate: 20%	C 100 + 2400 TAX-	0. 100. 2,000.00
		+ 3600 TAX- TAX- =	+ + TAX- + TAX- + TAX =
			1,300. 2,400.00 400.00 1,700.00 2,100. 3,000.00 600.00 2,700.00

## 5 Electrical Characteristics

### ■ Absolute Maximum Ratings

Items	Sym.	Min.	Max.	Unit
Supply Voltage	VDD-VSS	-0.3	2.0	V
Input Voltage	V <sub>IN</sub>	-0.3	VDD+0.3	V
Operating Temperature	T <sub>OP</sub>	0	50 / *70	°C
Storage Temperature	T <sub>STG</sub>	-55	+125	°C

**Note:** \* Under development, available on 2006/04/01

### ■ DC Electrical Characteristics

VDD=1.5V±0.3V, VSS=0V, TA=25°C, VEE=3.0±0.4V

Parameter	Pin Name	Symbol	Condition	Min.	Typ.	Max.	Unit
Operating Voltage	-	V <sub>DD</sub>	-	1.2	1.5	1.8	V
"1" Input Voltage	K3~K10	V <sub>IH</sub> (1)	-	V <sub>DD</sub> -0.4	-	V <sub>DD</sub>	V
"1" Input Voltage	K11~K14	V <sub>IH</sub> (2)	-	V <sub>EE</sub> -0.4	-	V <sub>EE</sub>	V
"0" Input Voltage	K3~K14	V <sub>IL</sub> (1)	-	0	-	0.4	V
"1" Input Voltage	RESET	V <sub>IH</sub> (3)	VDD=1.5V	0.6 V <sub>DD</sub>	-	V <sub>DD</sub>	V
"0" Input Voltage	RESET	V <sub>IL</sub> (2)	VDD=1.5V	0	-	0.4 V <sub>DD</sub>	V
"1" Output Voltage	SEGMENT COM1~3	V <sub>OH</sub> (1)	-	V <sub>EE</sub> -0.2	-	V <sub>EE</sub>	V
"0" Output Voltage	SEGMENT COM1~3	V <sub>OL</sub> (1)	-	0	-	0.2	V
"M" Output Voltage	COM1~3	V <sub>OM</sub>	-	V <sub>DD</sub> -0.2	-	V <sub>DD</sub> +0.2	V
"1" Output Voltage	K0~K7	V <sub>OH</sub> (2)	-	V <sub>DD</sub> -0.2	-	V <sub>DD</sub>	V
"0" Output Voltage	K0~K7	V <sub>OL</sub> (2)	-	0	-	0.2	V
"1" Output Resistance	SEGMENT COM1~3	R <sub>OH</sub>	V <sub>OUT</sub> =V <sub>EE</sub> -0.5V	-	-	70	KΩ
"0" Output Resistance	SEGMENT COM1~3	R <sub>OL</sub>	V <sub>OUT</sub> =0.5V	-	-	70	KΩ
Key Pull-down Resistance	K0~K10	R <sub>KEYL</sub> (1)	V <sub>OUT</sub> =V <sub>DD</sub> =1.2~1.8V	100	180	650	KΩ
Key Pull-up Resistance	K0~K7	R <sub>KEYH</sub> (1)	V <sub>OUT</sub> =0.5V	-	-	10	KΩ
	RESET	R <sub>KEYH</sub> (2)		50	-	370	KΩ
Switch Pull-down Resistance	K11~K14	R <sub>SW</sub> (1)	V <sub>OUT</sub> =V <sub>EE</sub>	240	400	800	KΩ
Oscillating Frequency	(Wait) TS1	F <sub>WAIT</sub>	V <sub>DD</sub> =1.2 ~ 1.8V	10.8	18	25.2	kHz
	(Operate) TS1	F <sub>OP</sub>	-	120	200	280	kHz
Frame Frequency	SEGMENT COM1~3	f <sub>F</sub>	Wait clock	56.3	93.8	131.3	Hz
			Fast clock	62.5	104	145.6	Hz
Supply Current	1 (WAIT)	I <sub>DDWAIT</sub>	V <sub>DD</sub> =1.5V, No load	-	3.0	4.5	μA
	2 (Operate)	I <sub>DDOP</sub>	V <sub>DD</sub> =1.5V, No load	-	13	20	μA
	3 (OFF)	I <sub>DDOFF</sub>	V <sub>DD</sub> =1.5V, No load	-	-	1.0	μA





**Pad Diagram**

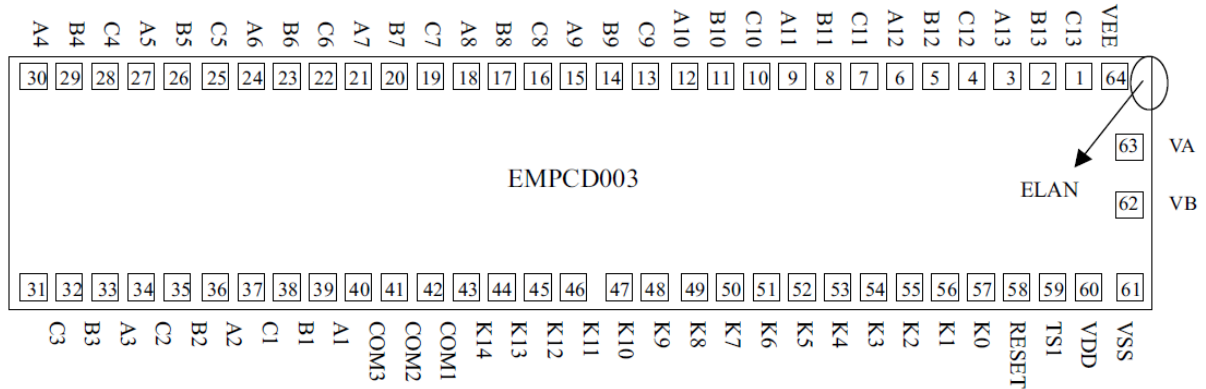

Pad No.	Symbol	X	Y
1	C13	1510.0	350.0
2	B13	1400.0	350.0
3	A13	1290.0	350.0
4	C12	1180.0	350.0
5	B12	1070.0	350.0
6	A12	960.0	350.0
7	C11	850.0	350.0
8	B11	740.0	350.0
9	A11	630.0	350.0
10	C10	520.0	350.0
11	B10	410.0	350.0
12	A10	300.0	350.0
13	C9	190.0	350.0
14	B9	80.0	350.0
15	A9	-30.0	350.0
16	C8	-140.0	350.0
17	B8	-250.0	350.0
18	A8	-360.0	350.0
19	C7	-470.0	350.0
20	B7	-580.0	350.0
21	A7	-690.0	350.0
22	C6	-800.0	350.0
23	B6	-910.0	350.0
24	A6	-1020.0	350.0
25	C5	-1130.0	350.0

Pad No.	Symbol	X	Y
26	B5	-1240.0	350.0
27	A5	-1350.0	350.0
28	C4	-1460.0	350.0
29	B4	-1570.0	350.0
30	A4	-1680.0	350.0
31	C3	-1680.0	-350.0
32	B3	-1570.0	-350.0
33	A3	-1460.0	-350.0
34	C2	-1350.0	-350.0
35	B2	-1240.0	-350.0
36	A2	-1130.0	-350.0
37	C1	-1020.0	-350.0
38	B1	-910.0	-350.0
39	A1	-800.0	-350.0
40	COM3	-690.0	-350.0
41	COM2	-580.0	-350.0
42	COM1	-470.0	-350.0
43	K14	-360.0	-350.0
44	K13	-250.0	-350.0
45	K12	-140.0	-350.0
46	K11	-30.0	-350.0
47	K10	98.0	-350.0
48	K9	208.0	-350.0
49	K8	318.0	-350.0
50	K7	428.0	-350.0
51	K6	538.0	-350.0
52	K5	648.0	-350.0
53	K4	758.0	-350.0
54	K3	868.0	-350.0
55	K2	978.0	-350.0
56	K1	1088.0	-350.0
57	K0	1198.0	-350.0
58	RESET	1308.0	-350.0
59	TS1	1418.0	-350.0
60	VDD	1540.1	-350.0
61	VSS	1666.7	-350.0
62	VB	1675.0	-59.3
63	VA	1675.0	130.7
64	VEE	1634.0	350.0

For PCB layout, the IC substrate must be connected to VSS.

Chip size: 3620 × 1010 μm