eSL Series

**16 Bits DSP
Sound Processor**

Product Specification

DOC. VERSION 1.5

ELAN MICROELECTRONICS CORP.

December 2008



Trademark Acknowledgments:

IBM is a registered trademark and PS/2 is a trademark of IBM.

Windows is a trademark of Microsoft Corporation.

ELAN and ELAN logo  are trademarks of ELAN Microelectronics Corporation.

Copyright © 2006~2008 by **ELAN Microelectronics Corporation**

All Rights Reserved

Printed in Taiwan

The contents of this specification are subject to change without further notice. ELAN Microelectronics assumes no responsibility concerning the accuracy, adequacy, or completeness of this specification. ELAN Microelectronics makes no commitment to update, or to keep current the information and material contained in this specification. Such information and material may change to conform to each confirmed order.

In no event shall ELAN Microelectronics be made responsible for any claims attributed to errors, omissions, or other inaccuracies in the information or material contained in this specification. ELAN Microelectronics shall not be liable for direct, indirect, special incidental, or consequential damages arising from the use of such information or material.

The software (if any) described in this specification is furnished under a license or nondisclosure agreement, and may be used or copied only in accordance with the terms of such agreement.

ELAN Microelectronics products are not intended for use in life support appliances, devices, or systems. Use of ELAN Microelectronics product in such applications is not supported and is prohibited.

NO PART OF THIS SPECIFICATION MAY BE REPRODUCED OR TRANSMITTED IN ANY FORM OR BY ANY MEANS WITHOUT THE EXPRESSED WRITTEN PERMISSION OF ELAN MICROELECTRONICS.



ELAN MICROELECTRONICS CORPORATION

Headquarters:

No. 12, Innovation Road 1
Hsinchu Science Park
Hsinchu, TAIWAN 308
Tel: +886 3 563-9977
Fax: +886 3 563-9966
<http://www.emc.com.tw>

Hong Kong:

Elan (HK) Microelectronics Corporation, Ltd.
Flat A, 19F., World Tech Centre
95 How Ming Street, Kwun Tong
Kowloon, HONG KONG
Tel: +852 2723-3376
Fax: +852 2723-7780

USA:

Elan Information Technology Group (U.S.A.)
PO Box 601
Cupertino, CA 95015
U.S.A.
Tel: +1 408 366-8225
Fax: +1 408 366-8225

Shenzhen:

Elan Microelectronics Shenzhen, Ltd.
3F, SSMEC Bldg., Gaoxin S. Ave. I
Shenzhen Hi-tech Industrial Park
(South Area), Shenzhen
CHINA 518057
Tel: +86 755 2601-0565
Fax: +86 755 2601-0500
elan-sz@elanic.com.cn

Shanghai:

Elan Microelectronics Shanghai, Ltd.
#23, Zone 115, Lane 572, Bibo Rd.
Zhangjiang Hi-Tech Park
Shanghai, CHINA 201203
Tel: +86 21 5080-3866
Fax: +86 21 5080-4600
elan-sh@elanic.com.cn

Contents

1	General Description	1
2	Features	1
3	Block Diagram	3
4	Selection Table	4
5	Pin Description	5
5.1	Power Supply	5
5.2	System Control	6
5.3	DAC Output	6
5.4	2-stage Amplifier and Touchpad Positioning.....	6
5.5	I/O Port	7
6	Electrical Characteristics.....	9
6.1	CPU Voltage – Frequency Graph.....	9
6.2	Absolute Maximum Ratings	10
6.3	DC Characteristics.....	10
7	Application Circuits.....	12

Specification Revision History

Doc. Version	Revision Description	Date
1.0	<ol style="list-style-type: none">1. Modified the Pin description in Section 52. Modified the Operating temperature Range in Section 6.2	2006/10/31
1.1	<ol style="list-style-type: none">1. Added a comment after the Selection table in Section 42. Modified the Application Circuits diagram in Section 73. Modified the Sampling Rate Range in Section 4	2007/04/12
1.2	<ol style="list-style-type: none">1. Added eSL0322. Modified the Temperature Range in Section 6.23. Modified the Power Supply voltage in Section 6.34. Added algorithm support such as beat tracking, sound location, speech control, pitch control in Section 2 and 4	2007/08/10
1.3	<ol style="list-style-type: none">1. Added package information in Section 42. Modified the Application Circuits in Section 7	2007/11/10
1.4	<ol style="list-style-type: none">1. Modified the PWM current in Section 6.32. Added Port C DC Characteristics in Section 6.3	2008/01/10
1.5	<ol style="list-style-type: none">1. Modified the Application Circuits Diagram in Section 72. Modified the Algorithm support in Sections 2 and 4	2008/12/04



1 General Description

The ELAN eSL Series IC is a 16-bit DSP Sound Processor with multi-channel speech and instrument playback. It is based on ELAN 16-bit DSP platform. The series has a powerful 16-bit DSP architecture that handles most of the speech/melody functions. Speech and melody can be played back simultaneously. The speech synthesis is implemented by software, and it supports a wide range of compression bit rates and various volume levels. The ELAN eSL Series provides real instrument waveform to obtain good quality melody. The ELAN eSL peripheral includes ADC, RTC, Timer, WDT, SPI, DAC, PWM, etc.

The ELAN eSL Series IC offers Fast, Sleep, Green, and Slow modes of operation. The use of Green/Slow mode will further reduce the power consumption. Green mode also provides RTC function for wake-up purposes.

The ELAN eSL Series enhanced features make it suitable for versatile voice and sound effect product applications. These enhanced versatile features allow users to create products with a wide variety of new fancy ideas.

The ELAN eSL Series has extreme high performance in speech application based on powerful DSP architecture and good algorithm in audio compression. Up to 2-channel speech with different channel sample rate or a single channel speech + 8-channel melody are provided.

2 Features

- MCU
 - 16-bit RISC CPU architecture
 - CPU clock: 20 MHz @ 3.3V
 - Programmable PLL
 - Four CPU operation modes: Fast, Slow, Green, Sleep
 - Powerful DSP Instruction Set supports multiplication, division, repeat, loop and soft interrupt instructions.
 - Saturation mode is supported for multimedia applications.
 - 8 general purpose registers (GPR)
 - 21 interrupt sources with 2-level priority
- Memory
 - 32K-word Program Memory
 - 2K-word Data RAM
 - 032/128/256/512K-word Data ROM



- Peripherals
 - Real Time Clock (RTC) with wake-up function
 - Four 8-bit timers, two general purpose timers, two multiple-function timers
 - 8-bit Watchdog Timer (WDT) with general purpose timer capability
 - 40 GPIO + 8 Outputs
 - Serial Peripheral Interface (SPI)
 - 12-bit Analog to Digital Converter (ADC) with touch panel and MIC inputs
 - 12-bit current-steering Digital to Analog Converter (DAC)
 - 10-bit resolution Pulse Width Modulation (PWM)

- Algorithm
 - Built-in software voice synthesizer (0.8K ~ 96Kbps @ 8kHz)
 - Multiple Flash with volume level option
 - Directly controls port output value by waveform (waveform control port).
 - Supports mark number in waveform with ROM optimized configuration.
 - Up to 2-channel speech with different channel sample rate or 1-channel speech + 8-channel melody
 - Voice recording in 12, 16, 20, and 32 Kbps @ 8kHz
 - Supports beat tracking function to detect music tempo.
 - Supports speed control to adjust playback speed.
 - Supports pitch control to change voice pitch.
 - Supports sound source detection function to detect the angle of sound position.
 - Supports speaker dependent recognition to recognize voice command and control function which is dependent on the speaker.
 - Supports speaker independent recognition to recognize voice command and control function which is independent on the speaker.
 - Supports handwriting recognition engine to recognize characters, numerals, symbols, and gestures.

3 Block Diagram

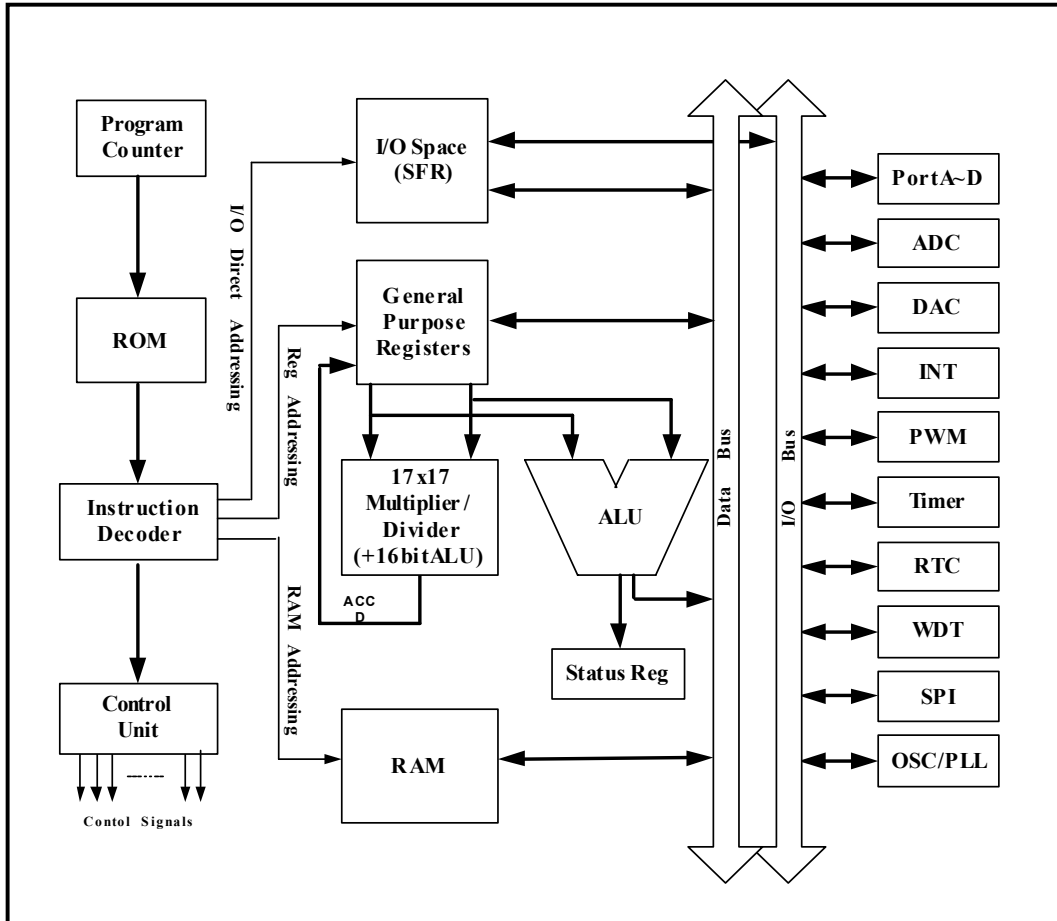

Figure 3-1 ELAN eSL System Block Diagram



4 Selection Table

The ELAN eSL Series integrates an extensive range of features, most of which are common to all devices, except for some distinctive features like, Data ROM, I/O count and Coding Type. For user convenience in the choice of the most suitable product for their application, the following table is provided, which enumerates the main features of each device.

Product No.	eSL032	eSL128	eSL256	eSL512	eSL032 A/B*	eSL128 A/B*	eSL256 A/B*	eSL512 A/B/C*
Pin Count	81							
Program ROM	32K×16							
Data RAM	2K×16							
Data ROM	32K×16	128K×16	256K×16	512K×16	32K×16	128K×16	256K×16	512K×16
Timer	4 × 8-bit timers							
Watchdog	Yes							
PWM	10-bit							
A/D Converter	12-bit							
Current D/A	12-bit							
SPI	1 set							
I/O	40 I/O ports + 8 Output ports							
Audio**	Up to 2-channel speech with different channel sample rate or 1-channel speech + 8-channel melody							
Coding Type**	12K/16K/20K/24K/32K/40K/48K/96K bps @ 8kHz				0.8K~96K bps @ 8kHz ***			
Sampling Rate Range**	6kHz ~ 48kHz							
Algorithm	none				**			

* The product number “A, B, C” means advanced audio algorithm is supported.

** For more detailed information, refer to the Assembler Reference Manual, C Macro Reference Manual and related Application Notes.

***eSL512C Coding Type is 12K/16K/20K/24K/32K/40K/48K/96K bps @ 8kHz, the same with eSL.

5 Pin Description

5.1 Power Supply

Name	Type	Supply Voltage	Description
VDD_CPU	P	3V	Positive power supply for CPU, digital peripheral and DRAM
VDD_PM	P	3V	Positive power supply for PROM, DROM and POR
VDD_OSC	P	3V	Positive power supply for Oscillator system and PLL
IOVDD_PWM	P	3V, 5V	Positive power supply for Port D and PWM I/O pad
IOVDD_PB	P	3V, 5V	Positive power supply for Port A.2~15 and Port B I/O pad
IOVDD_PC	P	3V, 5V	Positive power supply for Port C I/O pad
VSS_CPU	P	GND	Negative power supply for CPU, digital peripheral and DRAM
VSS_PM	P	GND	Negative power supply for PROM, DROM and POR
VSS_OSC	P	GND	Negative power supply for Oscillator system and PLL
IOVSS_PWM	P	GND	Negative power supply for Port D and PWM I/O pad
IOVSS_PB	P	GND	Negative power supply for Port A.2~15 and Port B I/O pad
IOVSS_PC	P	GND	Negative power supply for Port C I/O pad
AVDD_AD	P	3V	Positive power supply for A/D
AVDD_DA	P	3V	Positive power supply for D/A
AVSS_AD	P	GND	Negative power supply for A/D
AVSS_DA	P	GND	Negative power supply for D/A
VREF	P	3V	External reference voltage input pin for A/D and MIC
RVIN	P	5V	Regulator voltage input
RVOUT	P	3V	Regulator voltage output 3.0V

NOTE

The AVDD_AD, VREF are analog voltage input that need to be separated with the other digital voltage input to reduce noise interference. For example, you can use an on-chip regulator to be the analog voltage source. Or you can refer to the development board reference circuit.

5.2 System Control

Name	Type	Description
RSTB	I	RSTB is the low active global reset input *
TEST	I	Test mode select pin (High active). Internal pull down. For chip internal test only, normally connect to VSS.
OSCI	I	Crystal or RC oscillator connecting pin RC or Crystal selection is by OSCS pin
OSCO	O	Crystal oscillator connecting pin
OSCS	I	RC or Crystal selection: 0 = RC 1 = Crystal
PLLC	I	PLL loop filter capacitor **

* This pin has an internal pull-up 150 K Ω resistor. Refer to the Application Circuits.

** This pin must be connected to a 47nF capacitor and to ground. Refer to the Application Circuits.

5.3 DAC Output

Name	Type	Description
DACO	O	Current D/A output pin

5.4 2-stage Amplifier and Touchpad Positioning

Name	Type	Description
AMPO	O	Post Amplifier output
MIC	I	Microphone signal input (AC coupling from microphone signal)
AGC	I	Automatic Level Control adjustment pin
Xn	I	Touch Pad positioning for X axis under negative voltage level
Yn	I	Touch Pad positioning for Y axis under negative voltage level
XP/ADIN0	I	Touch Pad positioning for X axis under positive voltage level Analog input channel 0
YP/ADIN1	I	Touch Pad positioning for Y axis under positive voltage level Analog input channel 1

5.5 I/O Port

■ Port A Attributes and Definitions

Name	Function	Type	Description
PA[0]	GPIO	I/O	General-purpose I/O function
	PWM0	O	PWM Output 0
PA[1]	GPIO	I/O	General-purpose I/O function
	PWM1	O	PWM Output 1
PA[2]	GPIO	I/O	General-purpose I/O function
PA[3]	GPIO	I/O	General-purpose I/O function
PA[4]	GPIO	I/O	General-purpose I/O function
	TEX12	I	External Timer 2 clock input
PA[5]	GPIO	I/O	General-purpose I/O function
	TEX13	I	External Timer 3 clock input
PA [6]	GPIO	I/O	General-purpose I/O function
PA [7]	GPIO	I/O	General-purpose I/O function
PA [8]	GPIO	I/O	General-purpose I/O function
	TCCP2	I/O	Timer 2 capture input or compare output
PA [9]	GPIO	I/O	General-purpose I/O function
	TCCP3	I/O	Timer 3 capture input or compare output
PA [10]	GPIO	I/O	General-purpose I/O function
	EXINT0	I	External Interrupt 0 input
PA [11]	GPIO	I/O	General-purpose I/O function
	EXINT1	I	External Interrupt 1 input
PA [12]	GPIO	I/O	General-purpose I/O function with programmable high current
	/SS	I	SPI function In Slave mode: used as chip select input In Master mode: used as I/O pin with programmable high current
PA [13]	GPIO	I/O	General-purpose I/O function with programmable high current
	MOSI	I/O	SPI function (Master output / Slave input) with programmable high current
PA [14]	GPIO	I/O	General-purpose I/O function with programmable high current
	MISO	I/O	SPI function (Master input / Slave output) with programmable high current
PA [15]	GPIO	I/O	General-purpose I/O function with programmable high current
	SCK	I/O	SPI function with programmable high current In Master mode: used as serial clock output In Slave mode: used as serial clock input



■ **Port B Attributes and Definitions**

Name	Function	Type	Description
PB [7:0]	GPIO	I/O	General-purpose I/O function
		I	Wake-up function with programmable pull-up resistor
PB [15:8]	GPIO	I/O	General-purpose I/O function
		I	Wake-up function with programmable pull-up resistor

■ **Port C Attributes and Definitions**

Name	Function	Type	Description
PC [1:0]	GPIO	I/O	General-purpose I/O function
		I	Input with programmable pull-up resistor
PC [7:2]	GPIO	I/O	General-purpose I/O function
		I	Input with programmable pull-up resistor
	ADIN2~7	I	Analog Input channels

Note: Port C [7:2] is pin-shared with ADC input. There is no **Schmitt Trigger Input** when input is from Port C [7:2]

■ **Port D Attributes and Definitions**

Name	Function	Type	Description
PD [0]	GPO	O	General-purpose output function with high drive current (1 * Tg delay) *
PD [1]	GPO	O	General-purpose output function with high drive current (5 * Tg delay) *
PD [2]	GPO	O	General-purpose output function with high drive current (2 * Tg delay) *
PD [3]	GPO	O	General-purpose output function with high drive current (6 * Tg delay) *
PD [4]	GPO	O	General-purpose output function with high drive current (3 * Tg delay) *
PD [5]	GPO	O	General-purpose output function with high drive current (7 * Tg delay) *
PD [6]	GPO	O	General-purpose output function with high drive current (4 * Tg delay) *
PD [7]	GPO	O	General-purpose output function with high drive current (8 * Tg delay) *

* Tg = 4 nano-second for low noise design consideration

6 Electrical Characteristics

6.1 CPU Voltage – Frequency Graph

The speed of a MOS device depends on voltage, temperature, and process variation. Performance analysis is based on a combination of these three factors. The central operating condition is characterized at 3.3V, 25°C, and typical process parameters.

