eSL Series

**16 Bits DSP
Sound Processor**

Product Specification

DOC. VERSION 0.7

ELAN MICROELECTRONICS CORP.

June 2006



Trademark Acknowledgments:

IBM is a registered trademark and PS/2 is a trademark of IBM.

Windows is a trademark of Microsoft Corporation.

ELAN and ELAN logo  are trademarks of ELAN Microelectronics Corporation.

Copyright © 2005~2006 by **ELAN Microelectronics Corporation**

All Rights Reserved

Printed in Taiwan

The contents of this specification are subject to change without further notice. ELAN Microelectronics assumes no responsibility concerning the accuracy, adequacy, or completeness of this specification. ELAN Microelectronics makes no commitment to update, or to keep current the information and material contained in this specification. Such information and material may change to conform to each confirmed order.

In no event shall ELAN Microelectronics be made responsible for any claims attributed to errors, omissions, or other inaccuracies in the information or material contained in this specification. ELAN Microelectronics shall not be liable for direct, indirect, special incidental, or consequential damages arising from the use of such information or material.

The software (if any) described in this specification is furnished under a license or nondisclosure agreement, and may be used or copied only in accordance with the terms of such agreement.

ELAN Microelectronics products are not intended for use in life support appliances, devices, or systems. Use of ELAN Microelectronics product in such applications is not supported and is prohibited.

NO PART OF THIS SPECIFICATION MAY BE REPRODUCED OR TRANSMITTED IN ANY FORM OR BY ANY MEANS WITHOUT THE EXPRESSED WRITTEN PERMISSION OF ELAN MICROELECTRONICS.



ELAN MICROELECTRONICS CORPORATION

Headquarters:

No. 12, Innovation Road 1
Hsinchu Science Park
Hsinchu, Taiwan 30077
Tel: +886 3 563-9977
Fax: +886 3 563-9966
<http://www.emc.com.tw>

Hong Kong:

Elan (HK) Microelectronics Corporation, Ltd.
Rm. 1005B, 10/F Empire Centre
68 Mody Road, Tsimshatsui
Kowloon, HONG KONG
Tel: +852 2723-3376
Fax: +852 2723-7780
elanhk@emc.com.hk

USA :

Elan Information Technology Group (U.S.A.)
1821 Saratoga Ave., Suite 250
Saratoga, CA 95070
USA
Tel :+1 408 366-8225
Fax: +1 408 366-8220

Europe :

Elan Microelectronics Corp. (Europe)
Siewerdtstrasse 105
8050 Zurich, SWITZERLAND
Tel: +41 43 299-4060
Fax: +41 43 299-4079
<http://www.elan-europe.com>

Shenzhen:

Elan Microelectronics Shenzhen, Ltd.
SSMEC Bldg., 3F, Gaoxin S. Ave.
Shenzhen Hi-Tech Industrial Park
Shenzhen, Guandong, CHINA
Tel: +86 755 2601-0565
Fax: +86 755 2601-0500

Shanghai:

Elan Microelectronics Shanghai, Ltd.
23/Bldg. #115 Lane 572, Bibo Road
Zhangjiang Hi-Tech Park
Shanghai, CHINA
Tel: +86 21 5080-3866
Fax: +86 21 5080-4600

Contents

1	General Description.....	1
2	Features.....	1
3	Block Diagram.....	2
4	Selection Table.....	3
5	eSL series Pin Description.....	4
6	Electrical Characteristics	6
7	Application Block Diagram	9

Specification Revision History

Doc. Version	Revision Description	Date
0.1	Initial version	2005/03/03
0.2	<ol style="list-style-type: none">1. Modified the system frequency.2. Modified the IC's Product No.3. Added speech mark feature.	2005/05/20
0.3	<ol style="list-style-type: none">1. Modified the Features section.2. Added function description.3. Added the Application circuits.	2005/11/23
0.4	Added function description.	2006/01/20
0.5	Modified some features.	2006/03/06
0.6	Modified the Application examples.	2006/05/03
0.7	Modified the pin description	2006/06/14

1 General Description

The ELAN eSL Series IC is a 16-bit DSP Sound Processor with multi-channel speech and instrument playback. It is based on ELAN 16-bit DSP platform. The series has a powerful 16-bit DSP architecture that handles most of the speech/melody functions. Speech and melody can be played back simultaneously. The speech synthesis is implemented by software and supports a wide range of compression bit rates and various volume levels. The ELAN eSL Series provides real instrument waveform to obtain good quality melody. The ELAN eSL peripheral includes ADC, RTC, Timer, WDT, SPI, DAC, PWM, etc.

The ELAN eSL Series IC offer Fast mode, Sleep mode, Green mode, and Slow mode of operation. The use of Green/Slow mode will further reduce power consumption. The Green mode also provides RTC function for wake-up purpose.

The ELAN eSL Series enhanced features make it suitable for versatile voice and sound effect product applications; besides, users are motivated to explore a wide variety of new creative ideas and products.

The ELAN eSL Series has extreme high performance in speech application based on powerful DSP architecture and good algorithm in audio compression. We provide up to 2-channel speech with different channel sample rate or 1-channel speech + 8-channel melody.

2 Features

- MCU
 - 16-bit RISC CPU architecture
 - CPU clock: 20MHz @ 3.3V
 - Programmable PLL
 - Four CPU operation modes: fast, slow, green, sleep
 - Powerful DSP Instruction Set supports multiplication, division, repeat, loop and soft interrupt instructions
 - Saturation mode supported for multimedia applications
 - Eight general purpose registers (GPR)
 - 21 interrupt sources with 2-level priority
- Memory
 - 32K-word program memory
 - 2K-word data RAM
 - 128/256/512K-word data ROM
- Peripherals
 - Real Time Clock (RTC) with wake-up function
 - Four 8-bit timers, two general purpose timers, two multiple-function timers

- 8-bit Watchdog Timer (WDT) with general purpose timer capability
 - 40 GPIO + 8 Output
 - Serial Peripheral Interface (SPI)
 - 12-bit Analog to Digital Converter (ADC) with touch panel and MIC inputs
- Audio
- 12-bit current-steering Digital to Analog Converter (DAC)
 - 10-bit resolution Pulse Width Modulation (PWM)
 - Built-in software voice synthesizer (0.8K ~ 40Kbps@8kHz)
 - Multiple flash with volume level option
 - Control port output value directly by waveform (waveform control port)
 - Support mark code in waveform
 - Up to 2-channel speech with different channel sample rate or 1-channel speech + 8-channel melody

3 Block Diagram

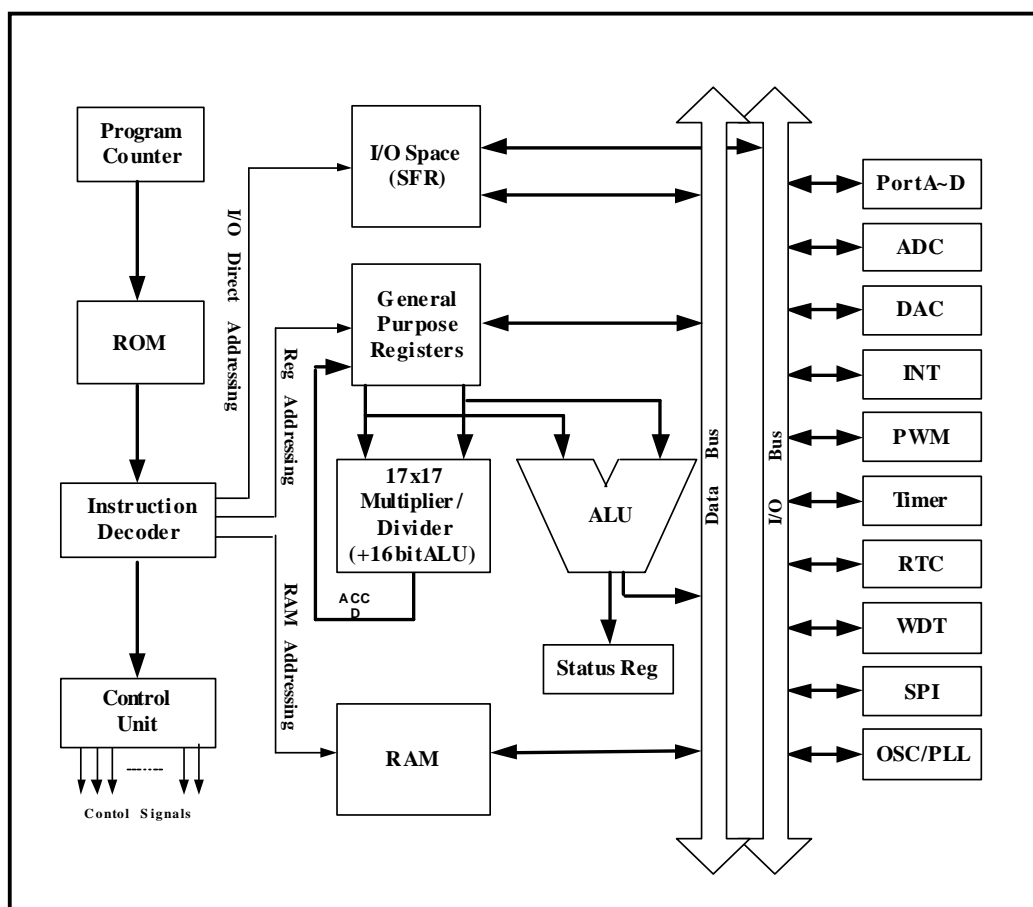

Figure 2-1 ELAN eSL System Block Diagram

4 Selection Table

The ELAN eSL Series integrates an extensive range of features, most of which are common to all devices, except for some distinctive features like Data ROM and Coding Type. For user convenience in the choice of the most suitable product for their application, the following table is provided, which enumerates the main features of each device.

Product No.	eSL128	eSL256	eSL512	eSL128A	eSL256A	eSL512A
Pin Count	81	81	81	81	81	81
Program ROM	32K * 16	32K * 16	32K * 16	32K * 16	32K * 16	32K * 16
Data RAM	2K * 16	2K * 16	2K * 16	2K * 16	2K * 16	2K * 16
Data ROM	128K * 16	256K * 16	512K * 16	128K * 16	256K * 16	512K * 16
Timer	4 * 8-bit	4 * 8-bit	4 * 8-bit	4 * 8-bit	4 * 8-bit	4 * 8-bit
Watchdog	Yes	Yes	Yes	Yes	Yes	Yes
PWM	10-bit	10-bit	10-bit	10-bit	10-bit	10-bit
Current D/A	12-bit	12-bit	12-bit	12-bit	12-bit	12-bit
A/D	12-bit	12-bit	12-bit	12-bit	12-bit	12-bit
SPI	1 set	1 set	1 set	1 set	1 set	1 set
I/O	40 I/O ports + 8 Output ports					
Audio	UP to 2-channel speech with different channel sample rate or 1-channel speech + 8-channel melody					
Coding type	12K/16K/20K/24K/32K/40K bps @8kHz			0.8K~40K bps @8kHz		

5 eSL series Pin Description

Name	Type	Description
VDD0	P	Positive power supply for CPU, digital peripheral and DRAM
VDD1	P	Positive power supply for PROM, DROM and Power On Reset (POR)
VDD2	P	Positive power supply for Oscillator system and PLL
VDD5	P	Positive power supply for PortD and PWM0/PortA.0, PWM1/PortA.1
VDD6	P	Positive power supply for PortA and PortB
VDD7	P	Positive power supply for PortC
VSS0	P	Negative power supply for CPU, digital peripheral and DRAM
VSS1	P	Negative power supply for PROM, DROM and Power On Reset (POR)
VSS2	P	Negative power supply for Oscillator system and PLL
VSS5	P	Negative power supply for PortD and PWM0/PortA.0, PWM1/PortA.1
VSS6	P	Negative power supply for PortA and PortB
VSS7	P	Negative power supply for PortC
AVDD0	P	Positive power supply for A/D and MIC
AVDD4	P	Positive power supply for D/A
AVSS0	P	Negative power supply for A/D and MIC
AVSS4	P	Negative power supply for D/A
VREF	P	External reference voltage input pin (MIC)
V5V	P	Regulator voltage input
VOUT	P	Regulator voltage output 3.0V
RSTB	I	RSTB is the global reset input (Low active)
TEST	I	Test mode select pin (High active). Internal Pull Down For testing purposes only. Normally connected to VSS.
OSCI	I	Crystal or RC oscillator connecting pin RC or Crystal selection is by OSCS pin
OSCO	O	Crystal oscillator connecting pin
OSCS	I	RC or Crystal selection: 0 = RC; 1= Crystal
PLLC	I	PLL loop filter capacitor
DACO	O	Current D/A output pin
AMPO	O	Post-Amplifier output
MIC	I	Microphone signal input (AC coupling from microphone signal)
AGC	I	Automatic Level Control adjustment pin
XN	I	Touch Pad positioning for X axis under negative voltage level

Name	Type	Description
YN	I	Touch Pad positioning for Y axis under negative voltage level
XP/ADIN0	I	Touch Pad positioning for X axis under positive voltage level
YP/ADIN1	I	Touch Pad positioning for Y axis under positive voltage level
PA[0~1]	I/O	General-purpose input and output function
	O	PWM voice output 0/1
PA[2~3]	I/O	General-purpose input and output function
PA[4~5]	I/O	General-purpose input and output function
	I	External timer 2/3 clock input
PA [6~7]	I/O	General-purpose input and output function
PA [8~9]	I/O	General-purpose input and output function
	I	Timer 2 / Timer 3 capture input or compare output
PA [10~11]	I/O	General-purpose input and output function
	I	External interrupt 0/1 input
PA [12]	I/O	General-purpose input and output function
	I	SPI function In Slave mode: used as chip select input In Master mode: used as I/O pin
PA [13]	I/O	General-purpose input and output function
	I/O	SPI function: Master output / Slave input
PA [14]	I/O	General-purpose input and output function
	I/O	SPI function (Master output / Slave input)
PA [15]	I/O	General-purpose input and output function
	I/O	SPI function In Master mode: used as serial clock output In Slave mode: used as serial clock input
PB [0~15]	I/O	General-purpose input and output function
	I	Wake-up function with programmable pull-up resistor
PC [0~1]	I/O	General-purpose input function
PC [2~7]	I/O	General-purpose input and output function
	I	A/D input with programmable pull-up resistor
PD [0~7]	O	General-purpose output function with high drive current

6 Electrical Characteristics

6.1 CPU Voltage – Frequency Graph

The speed of a MOS device depends on voltage, temperature, and process variation. Performance prediction is based on a combination of these three factors. The central operating condition is characterized at 3.3V, 25°C, and typical process parameters.

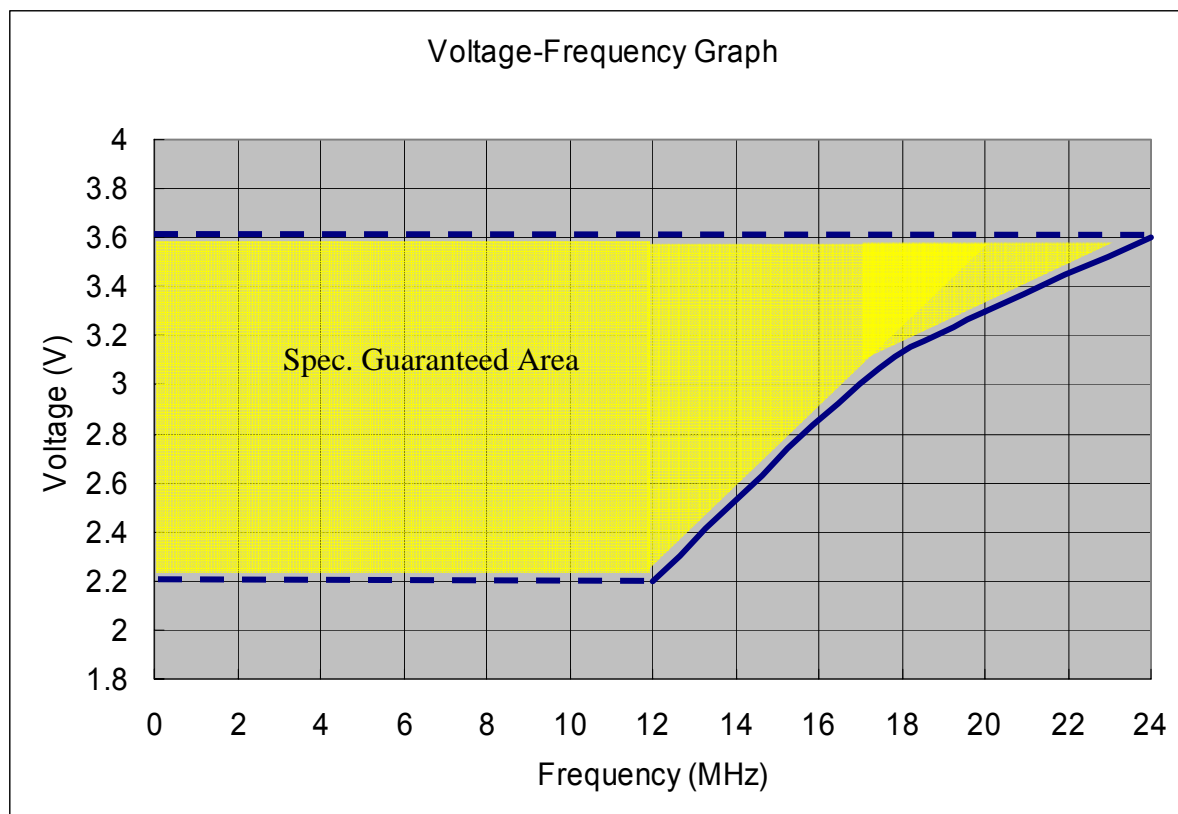

6.2 Absolute Maximum Ratings

Parameter	Pins	Symbol	Condition	Rated Value	Unit
Power supply voltage	VDD	V_{DD}	$T_A=25^\circ\text{C}$	-0.3 to +6.0	V
Input voltage	All Input	V_{IN}	$T_A=25^\circ\text{C}$	-0.3 to VDD+0.3	
Operating temperature range	—	T_A	—	-20 to +70	$^\circ\text{C}$
Storage temperature range	—	T_{STR}	—	-25 to +125	

6.3 DC Characteristics

Parameter	Pins	Symbol	Condition	Rated Value			Unit
				Min.	Typ.	Max.	
Power supply voltage	VDD	V_{DD}	2 batteries	2.2	3.0	3.6	V
			3 batteries	3.6	4.5	5.1	
Input voltage	—	V_{IN1}	—	$V_{DD}\times 0.7$	—	VDD	V
	—	V_{IN2}	—	0	—	$V_{DD}\times 0.3$	
Input threshold voltage (Schmitt Trigger)	—	—	—	$0.5\times V_{DD}$	—	$0.75\times V_{DD}$	V
	—	—	—	$0.2\times V_{DD}$	—	$0.4\times V_{DD}$	
Pull-up resistor	PC [7:0]	V_{PU0L}	$V_{in}=\text{GND}$	500	1000	1500	k Ω
	PC [7:0]	V_{PU0H}	$V_{in}=2\text{V}$	80	100	120	
	/RESET	V_{PU1L}	$V_{in}=\text{GND}$	500	1000	1500	
	/RESET	V_{PU1H}	$V_{in}=2\text{V}$	80	100	120	
Pull-down resistor	TEST	R_{PD}	$V_{in}=1\text{V}$	80	100	120	k Ω

Parameter	Pins	Symbol	Condition	Rated Value			Unit
				Min.	Typ.	Max.	
PortA,B output high current	IOH0	I_{OH0}	VDD=3V VOH=2.4V	-2	-3	—	mA
PortA,B output low current	IOL0	I_{OL0}	VDD=3V VOL=0.4V	2	3	—	
PortD output high current	IOH1	I_{OH1}	VDD=3V VOH=2.4V	-7	-10	—	
PortD output low current	IOL1	I_{OL1}	VDD=3V VOL=0.4V	7	10	—	
PWM output high current	PWM0 PWM1	I_{PWMH}	VDD=3V VOH=VDD/2 Max volume	-140	-150	-200	
PWM output low current	PWM0 PWM1	I_{PWML}	VDD=3V VOL=VDD/2 Max volume	140	150	200	
DAC output current	DAO	I_{DAC}	VDD = 2.2 ~ 3.3V	2.5	3	—	
Regulator output high current	VOUT	I_{OUTH}	VDD = 4.5V Vout = 3.0V PDB = 1	—	—	70	
Regulator output low current	VOUT	I_{OUTL}	VDD = 4.5V Vout = 3.0V PDB = 0	—	—	7	
Fast mode current consumption increment per MHz	—	I_{FAST}	VDD=3V No load DAC off	—	700	800	
Slow mode current consumption	—	I_{SLOW}	VDD=3V No load DAC off	—	70	80	
Green mode current consumption	—	I_{GREEN}	VDD=3V	—	8	10	
Sleep mode current consumption	—	I_{SLEEP}	VDD=3V Regulator on	—	1.5	2	
			VDD = 3V Regulator off	—	1	1.2	
CPU operation frequency	—	F_{sys}	VDD = 3V	14	16	—	MHz

7 Application Block Diagram

7.1 Application for Interactive/Educational Toys with LCD Function

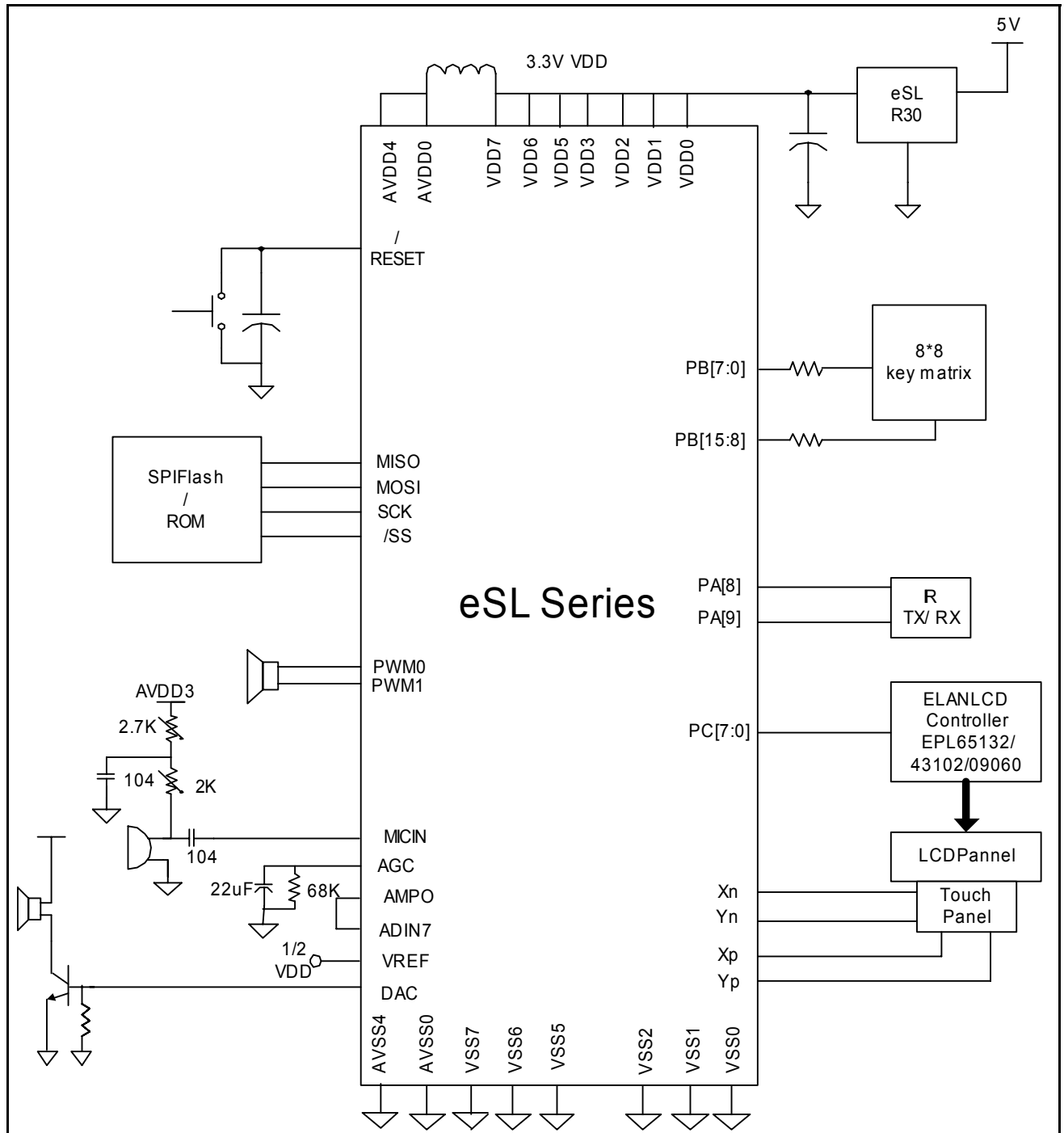

Figure 7-1 Interactive/Educational Toys with LCD Function Application Block Diagram, including SPI, PWM, DAC, IR, LCD Controller and Touch Panel for 3V/5V Support

7.2 Application for Interactive/Educational Toys with Hand Writing Recognition

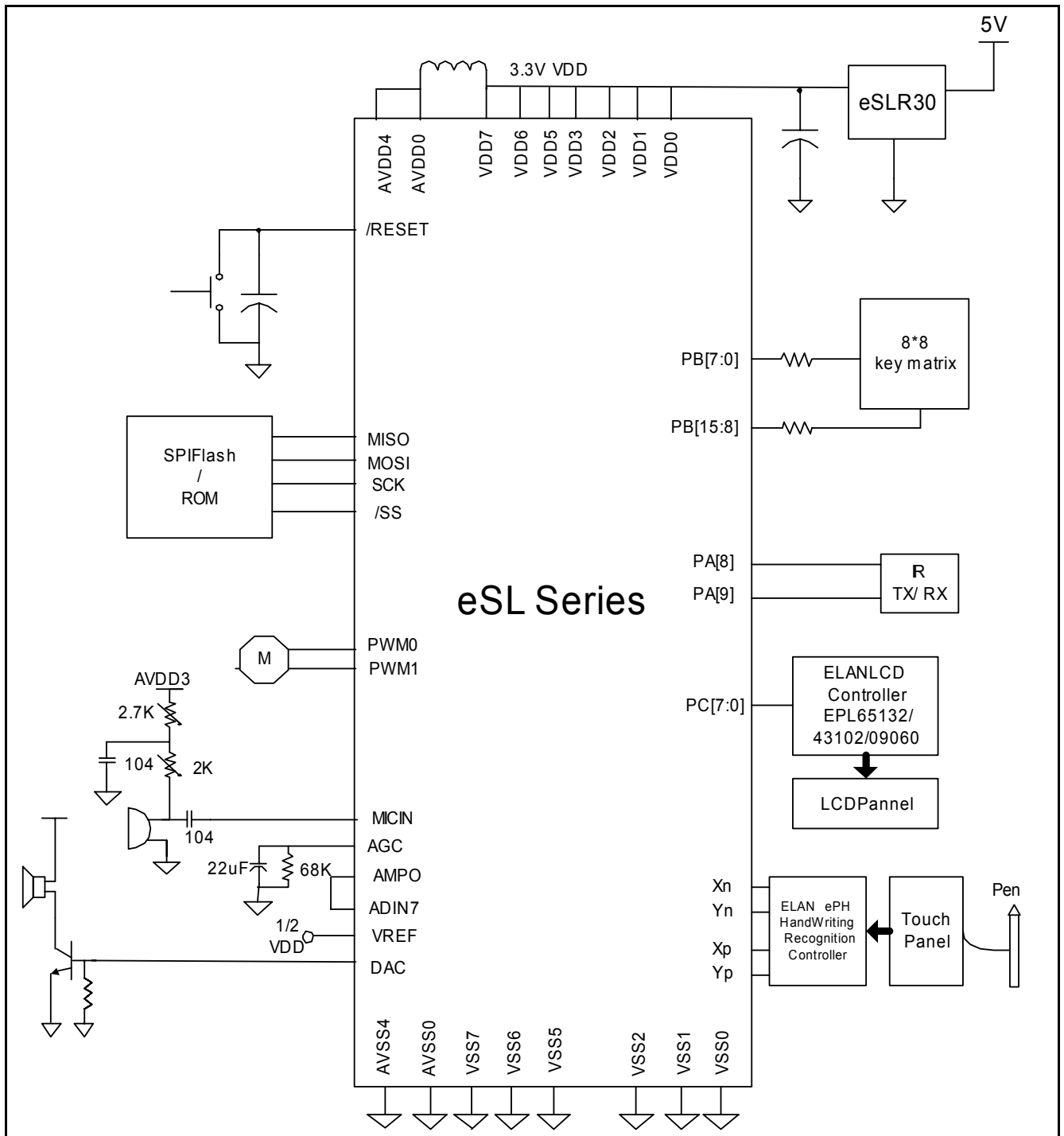

Figure 7-2 Interactive/Educational Toys with HWR Application Block Diagram, including SPI, PWM, DAC, IR, LCD Controller and Touch Panel for 3V/5V Support

7.3 Application Circuits

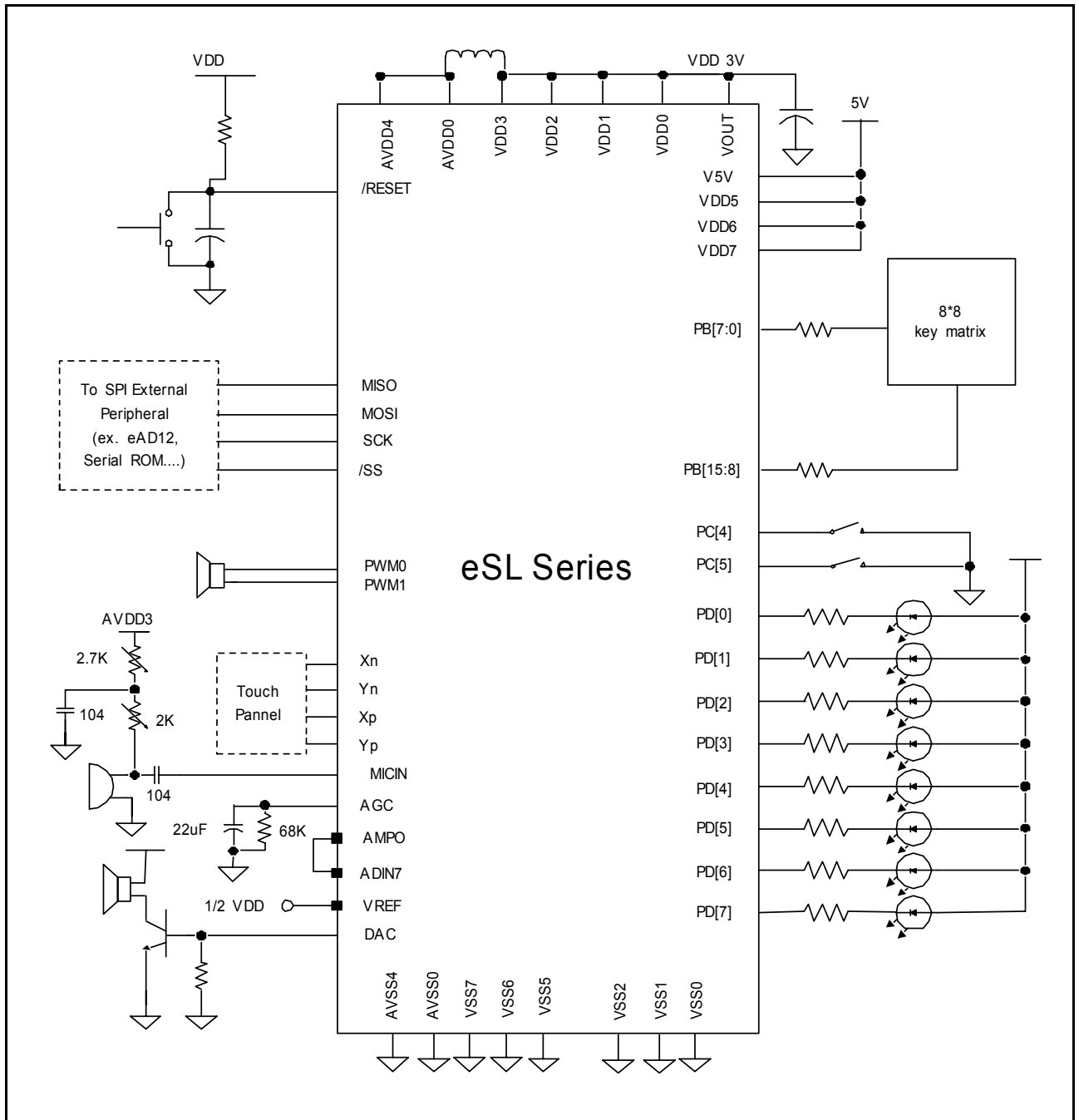

Figure 7-3 ELAN eSL Series Application Circuit Diagram with A/D, D/A, SPI and Regulator/PWM Driver for 3V/5V Support