eSC Series

**Tiny Turbo Controller
with Single Speech
Channel**

Product Specification

DOC. VERSION 1.2

ELAN MICROELECTRONICS CORP.

March 2006



Trademark Acknowledgments:

IBM is a registered trademark and PS/2 is a trademark of IBM.

Windows is a trademark of Microsoft Corporation.

ELAN and ELAN logo  are trademarks of ELAN Microelectronics Corporation.

Copyright © 2005~2006 by **ELAN Microelectronics Corporation**

All Rights Reserved

Printed in Taiwan

The contents of this specification are subject to change without further notice. ELAN Microelectronics assumes no responsibility concerning the accuracy, adequacy, or completeness of this specification. ELAN Microelectronics makes no commitment to update, or to keep current the information and material contained in this specification. Such information and material may change to conform to each confirmed order.

In no event shall ELAN Microelectronics be made responsible for any claims attributed to errors, omissions, or other inaccuracies in the information or material contained in this specification. ELAN Microelectronics shall not be liable for direct, indirect, special incidental, or consequential damages arising from the use of such information or material.

The software (if any) described in this specification is furnished under a license or nondisclosure agreement, and may be used or copied only in accordance with the terms of such agreement.

ELAN Microelectronics products are not intended for use in life support appliances, devices, or systems. Use of ELAN Microelectronics product in such applications is not supported and is prohibited.

NO PART OF THIS SPECIFICATION MAY BE REPRODUCED OR TRANSMITTED IN ANY FORM OR BY ANY MEANS WITHOUT THE EXPRESSED WRITTEN PERMISSION OF ELAN MICROELECTRONICS.



ELAN MICROELECTRONICS CORPORATION

Headquarters:

No. 12, Innovation Road 1
Hsinchu Science Park
Hsinchu, Taiwan 30077
Tel: +886 3 563-9977
Fax: +886 3 563-9966
<http://www.emc.com.tw>

Hong Kong:

**Elan (HK) Microelectronics
Corporation, Ltd.**
Rm. 1005B, 10/F Empire Centre
68 Mody Road, Tsimshatsui
Kowloon, HONG KONG
Tel: +852 2723-3376
Fax: +852 2723-7780
elanhk@emc.com.hk

USA :

**Elan Information Technology
Group (U.S.A.)**
1821 Saratoga Ave., Suite 250
Saratoga, CA 95070
USA
Tel :+1 408 366-8225
Fax: +1 408 366-8220

Europe :**Elan Microelectronics Corp.
(Europe)**

Siewerdtstrasse 105
8050 Zurich, SWITZERLAND
Tel: +41 43 299-4060
Fax: +41 43 299-4079
<http://www.elan-europe.com>

Shenzhen:**Elan Microelectronics
Shenzhen, Ltd.**

SSMEC Bldg., 3F, Gaoxin S. Ave.
Shenzhen Hi-Tech Industrial Park
Shenzhen, Guangdong, CHINA
Tel: +86 755 2601-0565
Fax: +86 755 2601-0500

Shanghai:**Elan Microelectronics
Shanghai, Ltd.**

23/Bldg. #115 Lane 572, Bibo Road
Zhangjiang Hi-Tech Park
Shanghai, CHINA
Tel: +86 21 5080-3866
Fax: +86 21 5080-4600

Contents

1	General Description	1
2	Features	1
3	Parts List	2
4	Applications	2
5	Pin Description	3
6	Special Function Description	3
6.1	Green Mode	3
6.2	Interrupt Mode	4
6.3	I/O Ports Description	4
6.3.1	Pull Low Structure of Ports 1, 2, and 3	5
7	Specifications	6
7.1	Absolute Maximum Ratings	6
7.2	Electrical Characteristics	6
8	Frequency Deviation	7
8.1	Freq. vs. R_{osc} ($V_{DD} = 3V$)	7
8.2	Freq. vs. V_{DD} ($R_{osc} = 33K\Omega$) Normal Mode	7
8.3	Freq. vs. V_{DD} ($R_{osc} = 51K\Omega$) Normal Mode	8
8.4	Freq. vs. V_{DD} ($R_{osc} = 51M\Omega$) Green Mode	8
9	Application Circuit	9
9.1	R Oscillator in Normal Mode (Not Using Green Mode)	9
9.2	Crystal Oscillator in Normal Mode (Not Using Green Mode)	9
9.3	R Oscillator in Normal Mode and Green Mode	10
9.4	Crystal Oscillator in Normal Mode and R Oscillator in Green Mode	10



Specification Revision History

Doc. Version	Revision Description	Date
1.0	eSC Series Initial Specification	2005/05/16
1.1	Added Auto Optional Oscillator	2005/11/15
1.2	Modify Oscillation Frequency	2006/03/22



1 General Description

The eSC series IC's are 4-bit microcontroller based sound processor with single-channel speech audio function. The series has a powerful 4-bit CPU that handles most of the speech functions. Wide range sampling rate and different volume levels are supported. It provides a synthesized speech to obtain good quality speech as well as one 4-bit input port, three 4-bit I/O ports, and one 4-bit output port (applicable to eSC100/120/170/200/270/320). By programming through the microcontroller, applications, such as section combination, trigger mode, output control, keyboard matrix, and other logic functions are easily put into effect.

In addition to Sleep mode, the eSC series IC's also offer Green mode which allows continuous operation at reduced or very low power consumption. Normal operation resumes at a preset time.

The enhanced functions will facilitate users in creating a wide variety of devices with new fancy features.

2 Features

- System clock:
 - 4 MHz @ 2.2 volts ~ 5.1 volts
 - 6 MHz @ 2.4V ~ 5.1V
- Auto optional crystal oscillator or RC oscillator
- Input/Output ports:
 - One Input port (P1) with software controlled pull low resistor
 - Three input/output ports (P2 ~ P4)
 - * P2 & P3 are software controlled with pull low resistor and wake-up function
 - * P4 is applicable to eSC065/080/100/120/170/200/270/320
 - One output port (P5) applicable to eSC100/120/170/200/270/320
- Sleep mode to conserve power (less than 1 μ A @ 3V standby current)
- Green mode for continuous operation at reduced or very low power consumption (less than 15 μ A @ 3V)
- 4 bits RISC type controller, each instruction takes 2 (90%) or 4 clock cycles
- 12 bits width per instruction, each instruction takes 1 (90%) or 2 words
- Total of 4 interrupts are available:
 - 2 interrupts for speech/high resolution timer operation
 - 1 interrupt for timer
 - 1 general purpose external interrupt



- 32K words maximum program address (except for eSC015 which has 28K words max)
- 8 total stacks
- 128 nibbles RAM
- Two channels can be arbitrarily assigned as speech channel/high resolution timer
- PCM/ADPCM algorithm for speech synthesis, which is transparent to users
- 16 steps DA volume control for channel output
- Optional 8 bits PWM or 10 bits traditional current DA
- 4 Flash with volume level options: 1/2, 1/4, 1/8, and 1/16

3 Parts List

IC Type	Time (Sec)	Stack	Program Size (Words)	ROM (Bits)	RAM (Bits)	I/O (× 4)	Cryst /Rst	IR	No. of Chan'l	DA
eSC015	15	8	28K	28K × 16	128 × 4	P1, P2, P3	Yes	Yes	1	1
eSC020	20	8	32K	32K × 16	128 × 4	P1, P2, P3	Yes	Yes	1	1
eSC030	30	8	32K	56K × 16	128 × 4	P1, P2, P3	Yes	Yes	1	1
eSC040	40	8	32K	64K × 16	128 × 4	P1, P2, P3	Yes	Yes	1	1
eSC065	65	8	32K	108K × 16	128 × 4	P1, P2, P3, P4	Yes	Yes	1	1
eSC080	80	8	32K	128K × 16	128 × 4	P1, P2, P3, P4	Yes	Yes	1	1
eSC100	100	8	32K	168K × 16	128 × 4	P1, P2, P3, P4, P5	Yes	Yes	1	1
eSC120	120	8	32K	192K × 16	128 × 4	P1, P2, P3, P4, P5	Yes	Yes	1	1
eSC170	170	8	32K	280K × 16	128 × 4	P1, P2, P3, P4, P5	Yes	Yes	1	1
eSC200	200	8	32K	320K × 16	128 × 4	P1, P2, P3, P4, P5	Yes	Yes	1	1
eSC270	270	8	32K	432K × 16	128 × 4	P1, P2, P3, P4, P5	Yes	Yes	1	1
eSC320	320	8	32K	512K × 16	128 × 4	P1, P2, P3, P4, P5	Yes	Yes	1	1

4 Applications

- Voice playback appliances
- Educational learning tools

5 Pin Description

Symbol	I/O	Function Description
OSCI	I	Crystal oscillator in / RC oscillator in Normal mode
OSCO	O	Crystal oscillator out / RC oscillator in Green mode
P1.0~3	I	Bits 0~3 of Port 1
P2.0~3	I/O	Bits 0~3 of Port 2
P3.0~3	I/O	Bits 0~3 of Port 3
P4.0~3	I/O	Bits 0~3 of Port 4 (applicable to eSC065/080/100/120/170/200/270/320)
P5.0~3	O	Bits 0~3 of Port 5 (applicable to eSC100/120/170/200/270/320)
VO1A	O	PWM voice output / Traditional DA
VO1B	O	PWM voice output
VDD0	I	Power
VSS0	I	Ground
RESETB	I	Reset pin (internal pull-high)
IRin	I	IR receiver pad
IRout	O	IR Transmit pad
VDD1	I	Power
VSS1	I	Ground

6 Special Function Description

6.1 Green Mode

Green mode is a very useful feature for conserving power (see table below) and in extending the life span of batteries. With Green mode, it is possible to achieve continuous operation at reduced or very low power consumption (less than 15 μ A@3V) and to resume normal operation at a preset time.

Mode	Current Consumption	Suitable Usage Condition
Normal mode	Maximum of 3mA @ $V_{DD} = 3V$	Complex computing, scenario flow control, high power consumption
Green mode	Maximum of 15 μ A @ $V_{DD} = 3V$	Long (preset) continuous operation at reduced or very low power consumption
Sleep mode	Maximum of 1 μ A @ $V_{DD} = 3V$	Sleep (no operation) & wake-up only, to conserve power



6.2 Interrupt Mode

A total of four interrupts are available. Each interrupt can be enabled or disabled and the interrupt status can be checked thru their corresponding flags.

Interrupt	Set	Behavior
Speech	1	8-bit resolution with pre-load counter
High resolution timer	1	8-bit resolution with pre-load counter
Timer	1	4 bits pre-load counter
External Interrupt	1	Occurs when P1.3 pad has a rising edge change

6.3 I/O Ports Description

The eSC series supports a total of five ports. Each port contains 4 bits. See Parts List (Section 3) to check which chip possesses which port.

Port 1: Input application only with pull low resistor and wake-up mechanism. The pull low resistor can be enabled or disabled, and the wake-up mechanism is always available (enabled).

Port 2: Available as input or output as defined by the Control Register. When set to input status, the pull low resistor can be enabled or disabled. When set to output status, another register is used to select port to sink or drive outside the circuit. The port is also equipped with a wake-up mechanism which can be enabled or disabled under either input or output mode.

Port 3: Port 3 characteristics are the same as Port 2 except for the wake-up mechanism which can be enabled or disabled under input mode only.

Port 4: Applicable in input or output mode which is controllable through Control Register. Both wake-up and pull low registers are not available under input mode. Thus, under input status, external signal cannot be set to floating state.

Port 5: For output application only

Each of the above port configurations can be summarized as follows:

Port	Available	Controllable I/O Direction	Input Mechanism	
			Pull Low	Wake-up
Port 1	I	x	√ (c)	√
Port 2	I/O	√ (c)	√ (c)	√ (c)
Port 3	I/O	√ (c)	√ (c)	√ (c)
Port 4	I/O	√ (c)	x	x
Port 5	O	x	x	x

Legend: I: input; I/O: input/output; O: output
 x: Not available
 √: Available
 (c): Can be enabled/disabled by register

6.3.1 Pull Low Structure of Ports 1, 2, and 3

The pull low resistor is only valid when ports are in input mode. Under input mode, a control register is used to enable or disable the pull low resistors.

A strong pull low resistor (100KΩ order) protects the pads from noise interference and is turned off to conserve power when pads status is “1” (High). The weak pull low resistor (1MΩ order) keeps the pads’ default value at “0” (Low).

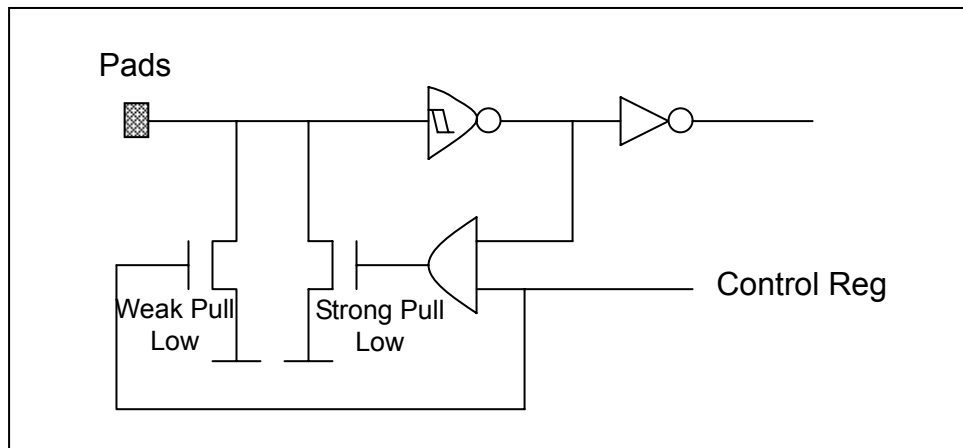

Figure 6-1 Ports 1, 2, & 3 Pull Low Structure

7 Specifications

7.1 Absolute Maximum Ratings

Parameter	Specification
Supply voltage (VDDx – Vssx)	-0.3V to + 6.0V
Input voltage	Vssx –0.3V to VDDx + 0.3V
Operating Temperature	0°C to 70°C
Storage Temperature	-55°C to 125°C

7.2 Electrical Characteristics

■ VDDx = 3V, VSSx = 0V, Ta = 25°C unless otherwise specified

Items	Sym.	Min	Typ.	Max.	Unit	Condition
Operating Voltage	V _{DDx}	2.2	3.0	5.1	V	F _{high} = 4 MHz
	V _{DDx}	2.4	3.0	5.1	V	F _{high} = 6 MHz
Standby Current	I _{DDs}	-	-	1.0	μA	Sleep Mode, No Load
Operating Mode Current	I _{green}	-	10	15	μA	Green Mode, No Load (F = F _{lo} = 32kHz)
	I _{op}	-	1.5	3	mA	No Load, D/A stop, (F = F _{high} = 4 / 6 MHz)
Drive Current of P2, P3, P4, P5, I _{Rout}	I _{OD}	2.0	5.0		mA	V _{OD} = 2.4V
Sink Current of P2, P3, P4, P5, I _{Rout}	I _{OS}	2.3	6.0		mA	V _{OS} = 0.4V
Input Current of P1, P2, P3, P4, I _{Rin}	I _{IH}	-	3.0	5	μA	
Output Current of VO1A	I _{VO1A}		3		mA	V _{VO1A} = 0.7V (Traditional Current DA)
Output Current of VO1A, VO1B	I _{VO1A/B}		200		mA	V _{vo1A/B} = 1/2 VDD (PWM DA)
Oscillation Resistor	R _{osch}	-	51.0	-	KΩ	F _{high} = 4 MHz
	R _{osch}	-	33.0	-	KΩ	F _{high} = 6 MHz
	R _{osclo}	-	1	-	MΩ	F _{lo} = 32kHz
Oscillation Frequency	F _{High}		4/6		MHz	Normal Mode
	F _{lo}		32		kHz	Green Mode