



義隆電子股份有限公司

ELAN MICROELECTRONICS CORP.

---

# EM78806A

**8-BIT MICRO-CONTROLLER**

Version 1.5

ELAN MICROELECTRONICS CORP.  
No. 12, Innovation 1<sup>st</sup> RD., Science-Based Industrial Park  
Hsin Chu City, Taiwan, R.O.C.  
TEL: (03) 5639977  
FAX: (03)5782037(SL) 5780617 (SA2)

---



User Application Note

1. ROM, OTP, ICE

ROM	OTP	ICE
EM78806A	EM78P806A	ICE806

2. Main Function Difference

	EM78806A	EM78P806A
Operation voltage	2.2 ~ 3.6V	2.5V ~ 5.5V

---



## I. General Description

The EM78806A is an 8-bit CID (Call Identification) RISC type microprocessor with low power , high speed CMOS technology . Integrated onto a single chip are on\_chip watchdog (WDT) , RAM , ROM , programmable real time clock /counter , internal interrupt , power down mode , LCD driver , FSK decoder , DTMF receiver , Tone generator and tri-state I/O . The EM78806A provides a single chip solution to design a CID of calling message display .

## II. Feature

### CPU

- Operating voltage range : 2.2V ~ 3.6V
- 8K× 13 on chip ROM
- 1.1K× 8 on chip RAM
- Up to 36 bi-directional tri-state I/O ports
- 8 level stack for subroutine nesting
- 8-bit real time clock/counter (TCC) with 8-bit prescaler
- Two sets of 8 bit counters can be interrupt sources
- Selective signal sources and overflow interrupt
- Programmable free running on chip watchdog timer
- 99.9% single instruction cycle commands
- four modes (Main clock 3.579 , 1.79, 0.895 or 0.447MHz generated by internal PLL)
  1. Sleep mode : CPU and Main clock turn off, 32.768KHz clock turn off
  2. Idle mode : CPU and Main clock turn off, 32.768KHz clock turn on
  3. Green mode : Main clock turn off, CPU and 32.768KHz clock turn on
  4. Normal mode : Main clock turn on , CPU and 32.768KHz clock turn on
- Input port wake up function
- 9 interrupt source , 4 external , 5 internal
- IO Port key scan function
- IO Port interrupt , pull high ,wake-up and open drain functions
- External Sub-Clock frequency is 32.768KHz
- Dual TONE Generators

### LCD

- LCD operation voltage chosen by software
- Common driver pins : 16 (8 of 16 Common shared by I/O)
- Segment driver pins : 40 (20 of 40 Segment shared by I/O)
- 1/4 bias
- 1/8,1/16 duty

### PACKAGE

- 100 pin QFP (EM78806AAQ, POVD disable) (EM78806ABQ, POVD enable) or 80 pin Chip (EM78806AH)

## III. Application

1. adjunct units
2. answering machines
3. feature phones



### IV.Pin Configuration

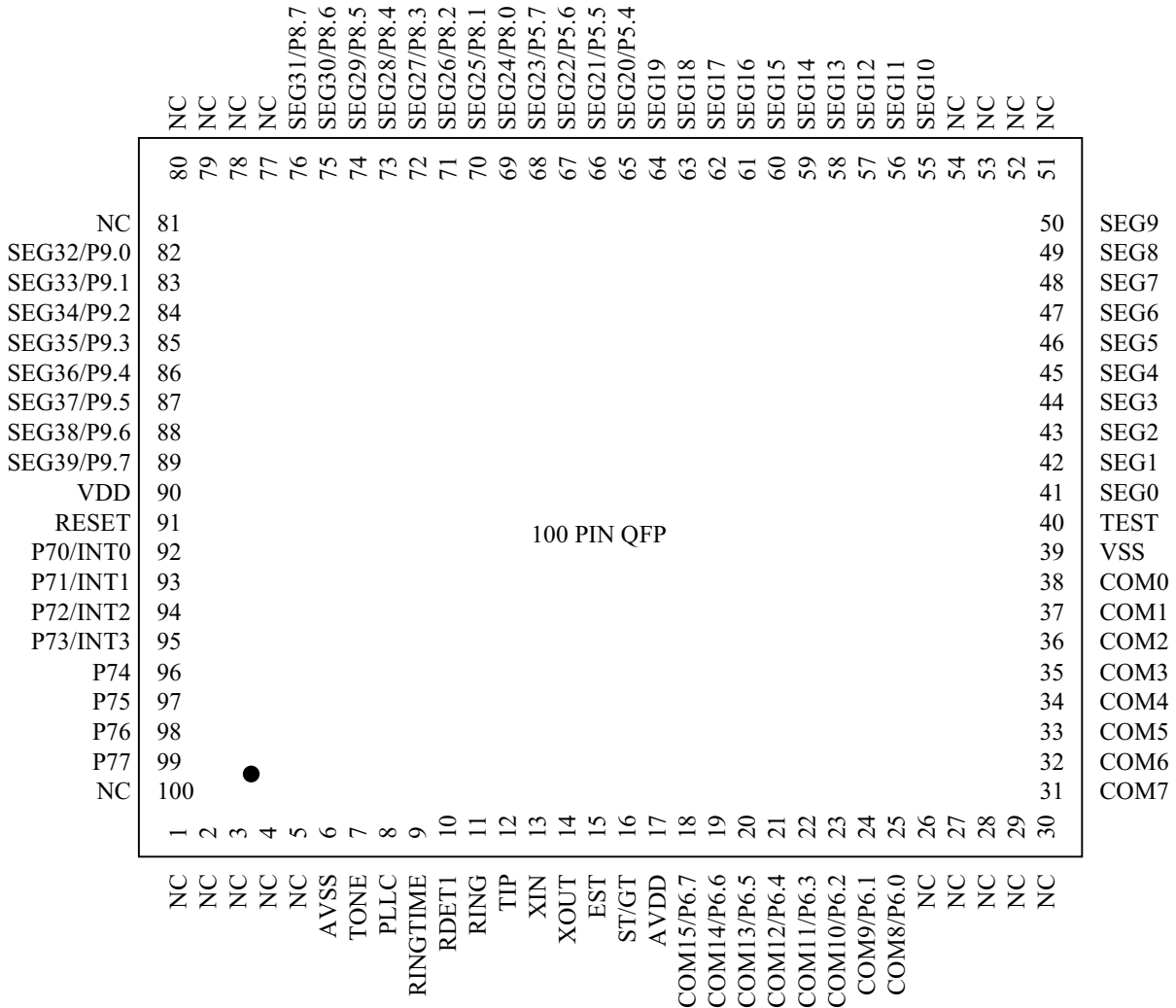

Fig.1 Pin Assignment

\* This specification are subject to be changed without notice.

V.Functional Block Diagram

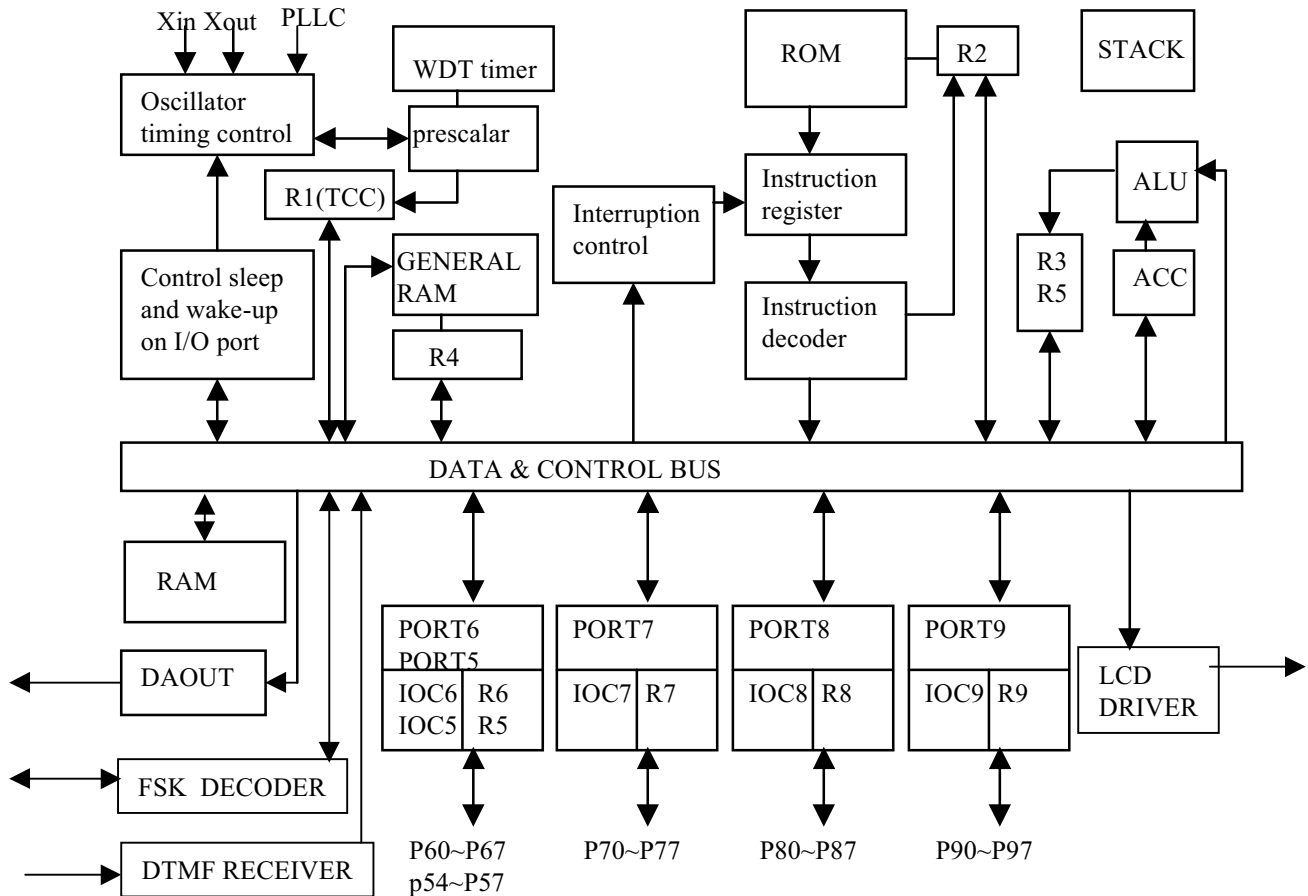

Fig.2 Block diagram



## VI.Pin Descriptions

PIN	I/O	DESCRIPTION
VDD	POWER	digital power
AVDD		analog power
VSS	POWER	digital ground
AVSS		analog ground
Xtin	I	Input pin for 32.768 kHz oscillator
Xtout	O	Output pin for 32.768 kHz oscillator
COM0..COM7	O O (PORT6)	Common driver pins of LCD drivers
COM8..COM15		
SEG0..SEG19	O O (PORT5) O (PORT8) O (PORT9)	Segment driver pins of LCD drivers
SEG20..SEG23		
SEG24..SEG31		
SEG32..SEG39		
PLLC	I	Phase loop lock capacitor, 0.01u to 0.047u with AVSS
TIP	I	Should be connected with TIP side of twisted pair lines
RING	I	Should be connected with RING side of twisted pair lines
RDET1	I	Detect the energy on the twisted pair lines . These two pins coupled to the twisted pair lines through an attenuating network.
/RING TIME	I	Determine if the incoming ring is valid. An RC network may be connected to the pin.
EST	O	Early steering output. Presents a logic high immediately when the digital algorithm detects a recognizable tone-pair (signal condition). Any momentary loss of signal condition will cause EST to return to a logic low.
ST/GT	I/O	Steering input/guard time output (bi-directional). A voltage greater than $V_{tst}$ detected at ST causes the device to register the detected tone-pair and update the output latch. A voltage less than $V_{tst}$ frees the device to accept a new tone-pair. The GT output acts to reset the external steering time-constant; its state is a function of EST and the voltage on ST .
INT0..INT3	PORT7(0..3)	PORT7(0)~PORT7(3) signal can be interrupt signals.
P5.4 ~P.57	PORT5	PORT5 can be INPUT or OUTPUT port each bit. And shared with Segment signal.
P7.0 ~P7.7	PORT7	PORT7 can be INPUT or OUTPUT port each bit. Internal Pull high function. Key scan function. Bit6,7 open drain function
P6.0 ~P6.7	PORT6	PORT6 can be INPUT or OUTPUT port each bit. And shared with Common signal.
P8.0 ~P8.7	PORT8	PORT 8 can be INPUT or OUTPUT port each bit. And shared with Segment signal.
P9.0 ~P9.7	PORT9	PORT 9 can be INPUT or OUTPUT port each bit. And shared with Segment signal. Bit6,7 has wake-up function.
TEST	I	Test pin into test mode , normal low
TONE	O	Tone generator's output
RESET	I	

\* This specification are subject to be changed without notice.

## VII. Functional Descriptions

### VII.1 Operational Registers

#### 1. R0 (Indirect Addressing Register)

\* R0 is not a physically implemented register. It is useful as indirect addressing pointer. Any instruction using R0 as register actually accesses data pointed by the RAM Select Register (R4).

#### 2. R1 (TCC)

\* Increased by an external signal edge applied to TCC, or by the instruction cycle clock.  
Written and read by the program as any other register.

#### 3. R2 (Program Counter)

- \* The structure is depicted in Fig.3
- \* Generates  $8K \times 13$  on-chip ROM addresses to the relative programming instruction codes.
- \* "JMP" instruction allows the direct loading of the low 10 program counter bits.
- \* "CALL" instruction loads the low 10 bits of the PC, PC+1, and then push into the stack.
- \* "RET" ("RETL k", "RETI") instruction loads the program counter with the contents at the top of stack.
- \* "MOV R2,A" allows the loading of an address from the A register to the PC, and the ninth and tenth bits are cleared to "0".
- \* "ADD R2,A" allows a relative address be added to the current PC, and contents of the ninth and tenth bits are cleared to "0".
- \* "TBL" allows a relative address be added to the current PC, and contents of the ninth and tenth bits don't change. The most significant bit (A10~A12) will be loaded with the content of bit PS0~PS2 in the status register (R5) upon the execution of a "JMP", "CALL", "ADD R2,A", or "MOV R2,A" instruction.

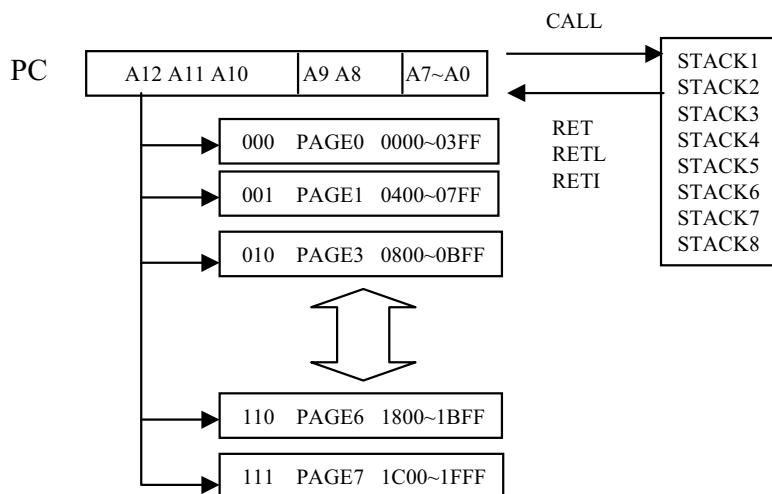

Fig.3 Program counter organization

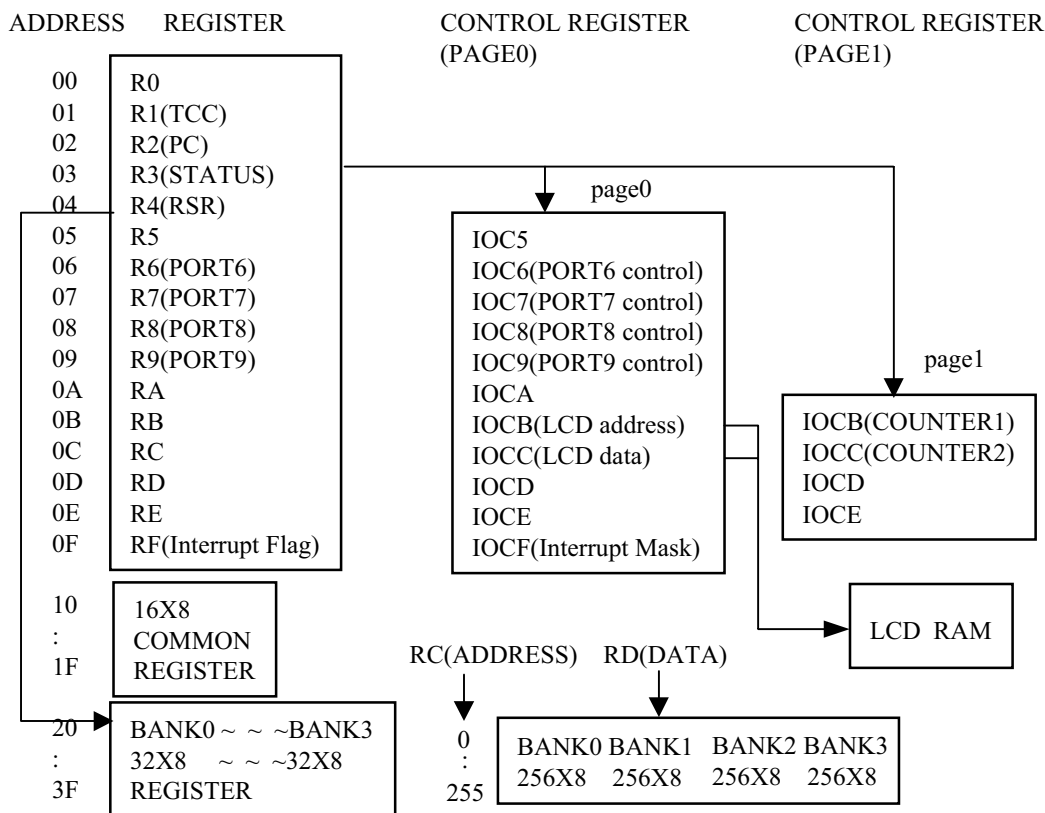

Fig.4 Data memory configuration

4. R3 (Status Register)

7	6	5	4	3	2	1	0
PAGE	P_TONE2	P_TONE1	T	P	Z	DC	C

- \* Bit 0 (C) Carry flag
- \* Bit 1 (DC) Auxiliary carry flag
- \* Bit 2 (Z) Zero flag
- \* Bit 3 (P) Power down bit. Set to 1 during power on or by a "WDTC" command and reset to 0 by a "SLEP" command.
- \* Bit 4 (T) Time-out bit. Set to 1 by the "SLEP" and "WDTC" command, or during power up and reset to 0 by WDT timeout.

EVENT	T	P	REMARK
WDT wake up from sleep mode	0	0	
WDT time out (not sleep mode)	0	1	
/RESET wake up from sleep	1	0	
power up	1	1	
Low pulse on /RESET	x	x	x .. don't care

- \*Bit5: Power control bit of Tone generator 1 . User can use this bit to power on the tone generator.
  - \*Bit6: Power control bit of Tone generator 2 . User can use this bit to power on the tone generator.
- Tone frequency controlled by IOCD and IOCE.

\* This specification are subject to be changed without notice.



R3(6,5)	Tone generator2	Tone generator1
00	Power off	Power off
01	Power off	Power on
10	Power on	Power off
11	Power on	Power on

\* Bit 7 PAGE : change IOCB ~ IOCE to another page , 0/1 => page0 / page1

#### 5. R4 (RAM Select Register)

- \* Bits 0 ~ 5 are used to select up to 64 registers in the indirect addressing mode.
- \* Bits 6 ~ 7 determine which bank is activated among the 4 banks.
- \* See the configuration of the data memory in Fig. 5.

#### 6. R5 (Program Page Select Register)

7	6	5	4	3	2	1	0
R57	R56	R55	R54	PWDN	PS2	PS1	PS0

\* Bit 0 (PS0) ~ Bit2 (PS2) Page select bits should be set before JMP or CALL instruction.

Page select bits

PS2	PS1	PS0	Program memory page (Address)
0	0	0	Page 0
0	0	1	Page 1
0	1	0	Page 2
0	1	1	Page 3
1	0	0	Page 4
1	0	1	Page 5
1	1	0	Page 6
1	1	1	Page 7

User can use PAGE instruction to change page. To maintain program page by user. Otherwise, user can use far jump (FJMP) or far call (FCALL) instructions to program user's code. And the program page is maintained by EMC's compiler. It will change user's program by inserting instructions within program.

\*Bit3 : PWDN : DTMF receiver circuit power control signal. Be sure open main clock before using DTMF receiver circuit . A logic low applied to PWDN will shut down power of the device to minimize the power consumption in a standby mode. It stops functions of the filters.

0/1= power down/ power up

\*Bit4 ~7: 4-bit I/O registers for Port 5(4:7).

#### 6. R6 ~ R9 (Port 6 ~ Port 9)

\* Four 8-bit I/O registers.

#### 7. RA (FSK Status Register)

7	6	5	4	3	2	1	0
IDLE	/358E	CLK2	CLK1	/FSKPWR	DATA	/CD	/RD

- \* Bit0 (Read Only) (Ring detect signal)0/1 : Ring Valid/Ring Invalid
- \* Bit1(Read Only)(Carrier detect signal) 0/1 : Carrier Valid/Carrier Invalid
- \* Bit2(Read Only)(FSK demodulator output signal)

Fsk data transmitted in a baud rate 1200 Hz. Data from FSK demodulator when /CD is low.

- \* Bit3(read/write)(FSK block power up signal) FSK controlled by software totally.  
1/0 : FSK demodulator block power up/FSK demodulator power down
- \* The relation between Bit0 to Bit3 is shown in Fig.5

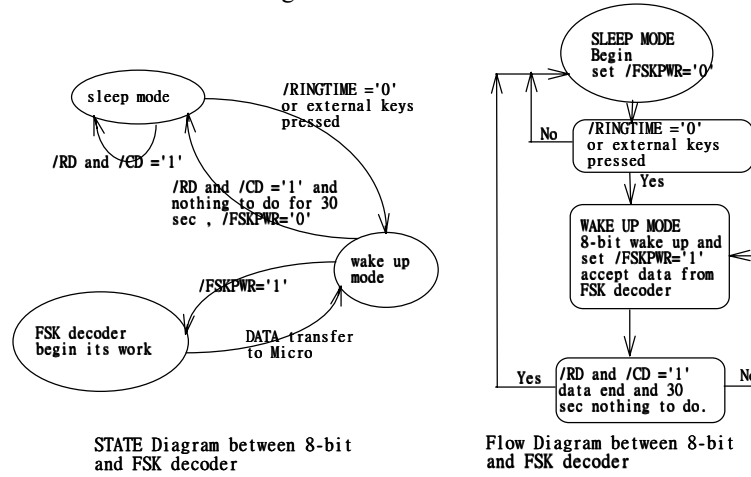

Fig.5 The relation between Bit0 to Bit3.

- \* Bit4~ Bit5: MAIN clock selection bits.  
User can choose the main clock by CLK1 and CLK2. All the clock is list below.

CLK2, CLK1	MAIN clock	/358E	CPU's clock
0,0	0.447MHz	1	0.447MHz
0,1	0.895MHz	1	0.895MHz
1,0	1.79MHz	1	1.79MHz
1,1	3.579MHz	1	3.579MHz
0,0	X	0	32768HZ
0,1	X	0	32768HZ
1,0	X	0	32768HZ
1,1	X	0	32768HZ

- \* Bit6(read/write)(PLL enable signal)  
0/1=DISABLE/ENABLE  
The relation between 32.768kHz and 3.579MHz can see Fig.6

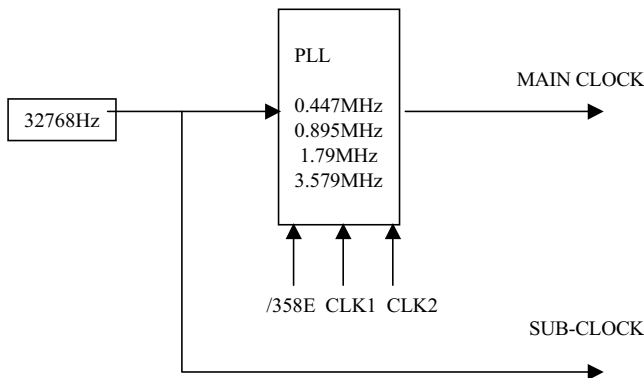

Fig.6 The relation between 32.768kHz and 3.579MHz .

\* Bit7 IDLE: sleep mode selection bit  
0/1=sleep mode/IDLE mode. This bit will decide SLEP instruction which mode to go.  
These two modes can be waken up by TCC clock or Watch Dog or PORT9 and run from "SLEP" next instruction.

Wakeup signal	SLEEP mode	IDLE mode	GREEN mode	NORMAL mode
	RA(7,6)=(0,0) + SLEP	RA(7,6)=(1,0) + SLEP	RA(7,6)=(x,0) no SLEP	RA(7,6)=(x,1) no SLEP
TCC time out	X	Wake-up + Interrupt + Next instruction	Interrupt	Interrupt
WDT time out	RESET	Wake-up + Next instruction	RESET	RESET
Port96,97 /RINGTIME pin	RESET	Wake-up + Next instruction	X	X
PORT70~73	RESET	Wake-up + Interrupt + Next instruction	Interrupt	Interrupt

\*P70 ~ P73 's wakeup function is controlled by IOCF(1,2,3) and ENI instruction.

\*P70 's wakeup signal is a rising or falling signal defined by CONT REGISTER bit7.

\*/RINGTIME pin , Port96,Port97 ,Port71,Port72 and Port73 's wakeup signal is a falling edge signal.

## 8. RB

7	6	5	4	3	2	1	0
P8SH	P8SL	TDP2	TDP1	LOW_BAT	CALL_2	/LPD	CALL_1

\*Bit2,Bit0:"00" to "11" are four blocks of CALLER ID RAM area. User can use 1.0K RAM with RC ram address.

\*Bit1(/LPD): Low battery detect disable/enable, 0/1= disable/enable

\*Bit3(LOW\_BAT):Low battery signal, 0/1 = battery voltage is low/normal.

If the battery voltage is under 2.5V then sends a '0' signal to RA register bit4 or a '1' signal to this Bit if VDD is over 2.6V.

The relation between /LPD,/POVD and /LOW\_BAT can see Fig..7

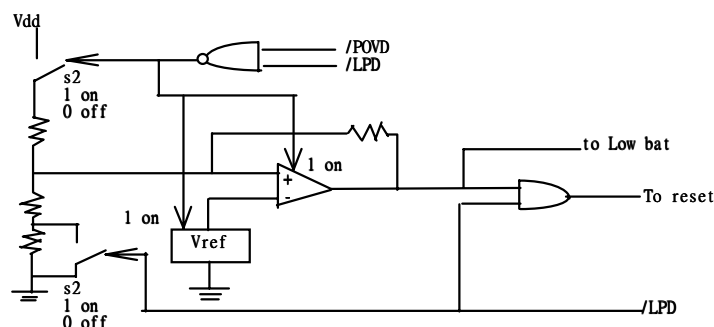

Fig.7 The relation between /LPD,/POVD

\* Bit 5 ~ 4:Tone detection present time setup.

TDP2,TDP1	Tdp
0,0	20 ms
0,1	15 ms
1,0	10 ms
1,1	5 ms

- \*Bit6: port8 low nibble switch, 0/1= normal I/O port/SEGMENT output .
- \*Bit7: port8 high nibble switch , 0/1= normal I/O port/SEGMENT output

9. RC

7	6	5	4	3	2	1	0
CIDA7	CIDA6	CIDA5	CIDA4	CIDA3	CIDA2	CIDA1	CIDA0

\* Bit 0 ~ Bit 7 select CALLER ID RAM address up to 256.

10. RD

\* Bit 0 ~ Bit 8 are CALLER ID RAM data transfer register.  
User can see RB register how to select CID RAM banks.

11. RE

7	6	5	4	3	2	1	0
STD	/WDTE	/WUP97	/WUP96	/WURING	LCD_C2	LCD_C1	LCD_M

- \* Bit0 (LCD\_M):LCD\_M decides the methods, including duty, bias, and frame frequency.
- \* Bit1~Bit2 (LCD\_C#):LCD\_C# decides the LCD display enable or blanking. change the display duty must set the "LCD\_C2,LCD\_C1" to "00".

LCD_C2,LCD_C1	LCD Display Control	LCD M	duty	bias
0 0	Change duty Disable(turn off LCD)	0 1	1/16 1/8	1/4 1/4
0 1	Blanking	:	:	:
1 1	LCD display enable	:	:	:

- \* Bit3 (/WURING, RING Wake Up Enable): used to enable the wake-up function of /RINGTIME input pin. (1/0=enable/disable)
- \* Bit4 (/WUP96, PORT9 bit6 Wake Up Enable): used to enable the wake-up function of PORT9 bit6 . (1/0=enable/disable)
- \* Bit5 (/WUP97, PORT9 bit7 Wake Up Enable): used to enable the wake-up function of PORT9 bit7 . (1/0=enable/disable)
- \* Bit6 (/WDTE, Watch Dog Timer Enable)  
Control bit used to enable Watchdog timer. (1/0=enable/disable)
- \* Bit7:STD: Delayed steering output. Presents a logic high when a received tone-pair has been registered and the output latch updated; returns to logic low when the voltage on St/GT falls below V<sub>tst</sub>. (0/1= No DATA/DATA Valid )

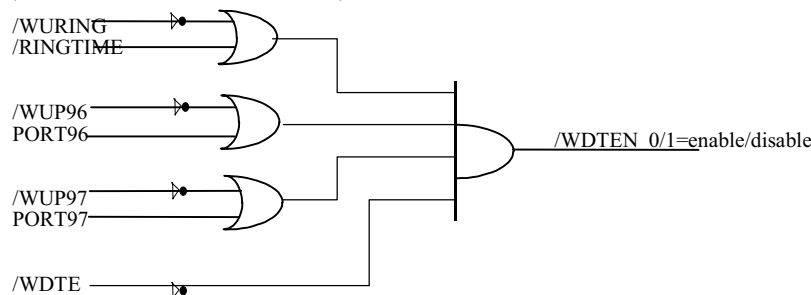

Fig.8 Wake up function and control signal

12. RF (Interrupt Status Register)

7	6	5	4	3	2	1	0
---	---	---	---	---	---	---	---

\* This specification are subject to be changed without notice.



/STD	FSKDATA	C8_2	C8_1	INT2/INT3	INT1	INT0	TCIF
------	---------	------	------	-----------	------	------	------

- \* "1" means interrupt request, "0" means non-interrupt
- \* Bit 0 (TCIF) TCC timer overflow interrupt flag. Set when TCC timer overflows .
- \* Bit 1 (INT0) external INT0 pin interrupt flag .
- \* Bit 2 (INT1) external INT1 pin interrupt flag .
- \* Bit 3 (INT2/INT3) external INT2 and INT3 pin interrupt flag .
  
- \* Bit 4 (C8\_1) internal 8 bit counter interrupt flag .
- \* Bit 5 (C8\_2) internal 8 bit counter interrupt flag .
- \* Bit 6 ( FSKDATA ) FSK data interrupt flag
- \* Bit 7 (/STD) The inverse signal of DTMF receiver data ready STD interrupt flag.
- \* High to low edge trigger , Refer to the Interrupt subsection. (INT0 can be triggered by low to high signal , refer to CONT bit 7)
- \* IOCF is the interrupt mask register. User can read and clear.

### 13. R10~R3F (General Purpose Register)

- \* R10~R3F (Banks 0~3) all are general purpose registers.

## VII.2 Special Purpose Registers

### 1. A (Accumulator)

- \* Internal data transfer, or instruction operand holding
- \* It's not an addressable register.

### 2. CONT (Control Register)

7	6	5	4	3	2	1	0
INT_EDGE	INT	TS	-	PAB	PSR2	PSR1	PSR0

- \* Bit 0 (PSR0) ~ Bit 2 (PSR2) TCC/WDT prescaler bits.

PSR2	PSR1	PSR0	TCC Rate	WDT Rate
0	0	0	1:2	1:1
0	0	1	1:4	1:2
0	1	0	1:8	1:4
0	1	1	1:16	1:8
1	0	0	1:32	1:16
1	0	1	1:64	1:32
1	1	0	1:128	1:64
1	1	1	1:256	1:128

- \* Bit 3 (PAB) Prescaler assignment bit.  
0/1 : TCC/WDT
- \* Bit 4 unused
- \* Bit 5 (TS) TCC signal source  
0: internal instruction cycle clock  
1: 16.38KHz
- \* Bit 6 : (INT)INT enable flag  
0: interrupt masked by DISI or hardware interrupt  
1: interrupt enabled by ENI/RETI instructions
- \* Bit 7 : INT\_EDGE  
0:P70 's interruption source is a rising edge signal.  
1:P70 's interruption source is a falling edge signal.

\* This specification are subject to be changed without notice.



\* CONT register is readable and writable.

### 3. IOC5

7	6	5	4	3	2	1	0
IOC54	IOC54	IOC54	IOC54	Q4	Q3	Q2	Q1

\*Bit0 ~ Bit3 : Q4~Q1: DTMF receiver data . To provide the code corresponding to the last valid tone-pair received (see code table). STD signal in RE Delayed steering output. Presents a logic high when a received tone-pair has been registered and the Q4~Q1 output latch updated and generate a interruption (IOCF has enabled); returns to logic low when the voltage on ST/GT falls below Vtst.

F low	F high	Key	PWDN	Q4~Q1
697	1209	1	1	0001
697	1336	2	1	0010
697	1477	3	1	0011
770	1209	4	1	0100
770	1336	5	1	0101
770	1477	6	1	0110
852	1209	7	1	0111
852	1336	8	1	1000
852	1477	9	1	1001
941	1209	0	1	1010
941	1336	*	1	1011
941	1477	#	1	1100
697	1633	A	1	1101
770	1633	B	1	1110
852	1633	C	1	1111
941	1633	D	1	0000
Any	Any	Any	0	XXXX (x:unknown)

\*Bit4~Bit7: I/O direction control registers of PORT5.

\* "1" put the relative I/O pin into high impedance (input port), while "0" put the relative I/O pin as output.

### 4. IOC6 ~ IOC9 (I/O Port Control Register)

\* Four I/O direction control registers.

\* "1" put the relative I/O pin into high impedance (input port), while "0" put the relative I/O pin as output.

### 5. IOCA

7	6	5	4	3	2	1	0
P9SH	P9SL	P6S	P5S	Bias3	Bias2	Bias1	SC

\* Bit 0 :SC (SCAN KEY signal ) 0/1 = disable/enable. Once you enable this bit , all of the LCD signal will have a low pulse during a common period. This pulse has 30us width. Please use the procedure to implement the key scan function.

- a. set port7 as input port
- b. set IOCD page0 port7 pull high

- c. enable scan key signal
- d. Once push a key . Set RA(6)=1 and switch to normal mode.
- e. Blank LCD. Disable scan key signal.
- f. Set P6S =0. Port6 sent probe signal to port7 and read port7. Get the key.
- g. Note!! A probe signal should be delay a instruction at least to another probe signal.
- h. Set P6S =1. Port6 as LCD signal. Enable LCD.

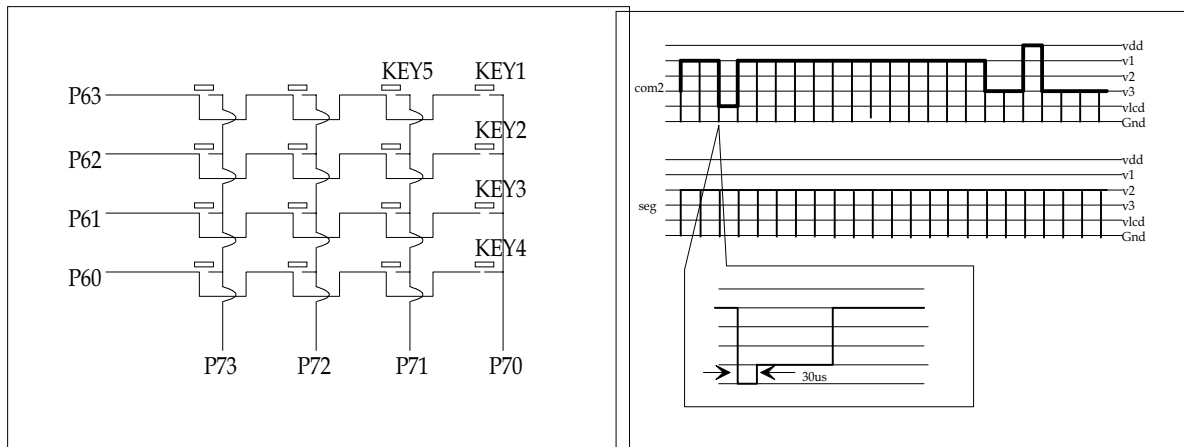

Fig.9. Key scan circuit

\* Bit 3~1 (Bias3~Bias1) Control bits used to choose LCD operation voltage .

LCD operate voltage	Vop (VDD 3.3V)	VDD=3.3V
000	0.60VDD	1.98V
001	0.66VDD	2.18V
010	0.74VDD	2.44V
011	0.82VDD	2.71V
100	0.87VDD	2.87V
101	0.93VDD	3.07V
110	0.96VDD	3.17V
111	1.00VDD	3.3V

\* Bit4: port5 nibble switch, 0/1= normal I/O port/SEGMENT output .

\* Bit5:port6 switch , 0/1= normal I/O port/COMMON output

\* Bit6:port9 low nibble switch , 0/1= normal I/O port/SEGMENT output . Bit7:port9 high nibble switch

## 6. IOCB (LCD ADDRESS)

PAGE0 : Bit6 ~ Bit0 = LCDA6 ~ LCDA0

The LCD display data is stored in the data RAM . The relation of data area and COM/SEG pin is as below:

COM15 ~ COM8	COM7 ~ COM0	
40H (Bit15 ~ Bit8)	00H (Bit7 ~ Bit0)	SEG0
41H	01H	SEG1
:	:	:
67H	27H	SEG39
:	:	Empty
7FH	3FH	Empty

PAGE1 : 8 bit up-counter (COUNTER1) preset and read out register . ( write = preset ) . After a interruption , it will count from "00".

## 7. IOCC (LCD DATA)

\* This specification are subject to be changed without notice.



PAGE0 : Bit7 ~ Bit0 = LCD RAM data register

PAGE1 : 8 bit up-counter (COUNTER2) preset and read out register . ( write = preset) After a interruption , it will count from "00".

8. IOCD

PAGE0 :

7	6	5	4	3	2	1	0
T17	T16	T15	T14	T13	T12	T11	T10

Tone generator 1 's frequency divider. Please Run in Normal mode .

Clock source = 111843Hz

T17~T10 = '11111111' => Tone generator1 will has 438Hz SIN wave output.

:

T17~T10 = '00000010' => Tone generator1 will has 55921Hz SIN wave output.

T17~T10 = '00000001' => Tone generator1 will has 111843Hz

T17~T10 = '00000000' => no used

PAGE1:

7	6	5	4	3	2	1	0
PH7	PH6	PH5	PH4	PH3	PH2	PH1	PH0

\* Bit 0 ~ 7 (/PH#) Control bit used to enable the pull-high of PORT7(#) pin.

1: Enable internal pull-high

0: Disable internal pull-high

9. IOCE

PAGE0 :

7	6	5	4	3	2	1	0
T27	T26	T25	T24	T23	T22	T21	T20

Tone generator 2 's frequency divider. Please Run in Normal mode.

Clock source = 111843Hz

T27~T20 = '11111111' => Tone generator1 will has 438Hz SIN wave output.

:

T27~T20 = '00000010' => Tone generator1 will has 55921Hz SIN wave output.

T27~T20 = '00000001' => Tone generator1 will has 111843Hz SIN wave output.

T27~T20 = '00000000' => no used

TONE1(IOCD)	ROW FREQ.						
(0xA0)	699.02Hz	1		2		3	A
(0x91)	771.33Hz	4		5		6	B
(0X83)	853.76Hz	7		8		9	C
(0X77)	939.86Hz	*		0		#	D
		1202.6 (0X5D)		1331.5(0X54)		1471.7(0X4C)	1644.8(0X44)
		TONE2(IOCE)					

PAGE1 :

7	6	5	4	3	2	1	0
OP77	OP76	C2S	C1S	PSC2	PSC1	PSC0	CDRD

\* Bit0: cooked data or raw data select bit , 0/1 ==> cooked data/raw data

\* Bit3~Bit1: counter1 prescaler , reset=(0,0,0)

(PSC2,PSC1,PSC0)	Scaler
0,0,0	1:1
0,0,1	1:2

0,1,0	1:4
0,1,1	1:8
1,0,0	1:16
1,0,1	1:32
1,1,0	1:64
1,1,1	1:128

- \* Bit4:counter1 source , (0/1)=(32768Hz/MAIN clock if enable)
- \* Bit5:counter2 source , (0/1)=(32768Hz/MAIN clock if enable) scale=1:1
- \* Bit6:P76 opendrain control (0/1)=(disable/enable)
- \* Bit7:P77 opendrain control (0/1)=(disable/enable)

### 10. IOCF (Interrupt Mask Register)

7	6	5	4	3	2	1	0
/STD	FSKDATA	C8_2	C8_1	INT2/INT3	INT1	INT0	TCIF

- \* Bit 0 ~ 7 interrupt enable bit.  
0: disable interrupt  
1: enable interrupt
- \* IOCF Register is readable and writable.

## VII.3 TCC/WDT Prescaler

There is an 8-bit counter available as prescaler for the TCC or WDT. The prescaler is available for the TCC only or WDT only at the same time.

- An 8 bit counter is available for TCC or WDT determined by the status of the bit 3 (PAB) of the CONT register.
- See the prescaler ratio in CONT register.
- Fig. 10 depicts the circuit diagram of TCC/WDT.
- Both TCC and prescaler will be cleared by instructions which write to TCC each time.
- The prescaler will be cleared by the WDTC and SLEEP instructions, when assigned to WDT mode.
- The prescaler will not be cleared by SLEEP instructions, when assigned to TCC mode.

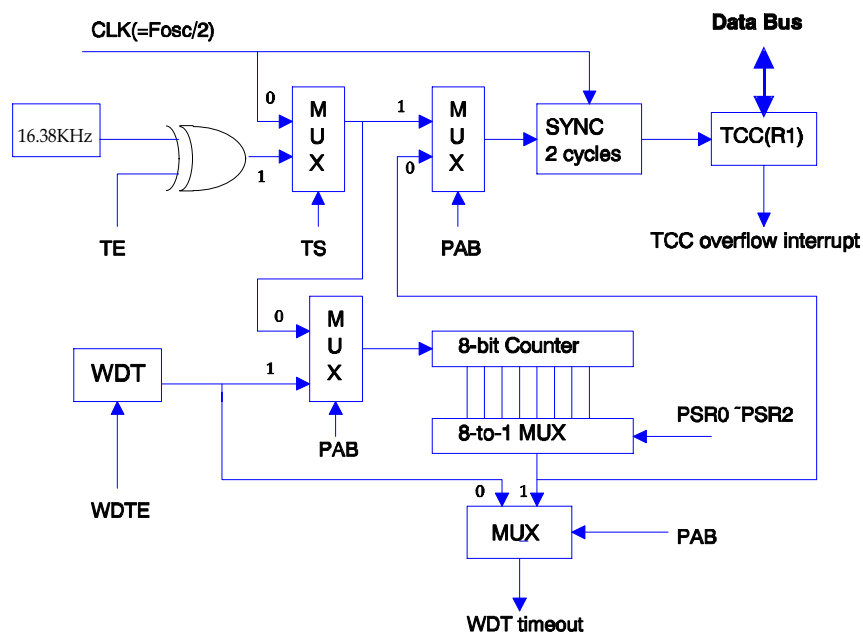

Fig.10 Block diagram of TCC WDT

### VII.4 I/O Ports

The I/O registers, Port5 ~ Port 9, are bi-directional tri-state I/O ports. Port 7 can be pulled-high internally by software control. The I/O ports can be defined as "input" or "output" pins by the I/O control registers (IOC6 ~ IOC9 ) under program control. The I/O registers and I/O control registers are both readable and writable. The I/O interface circuit is shown in Fig.11.

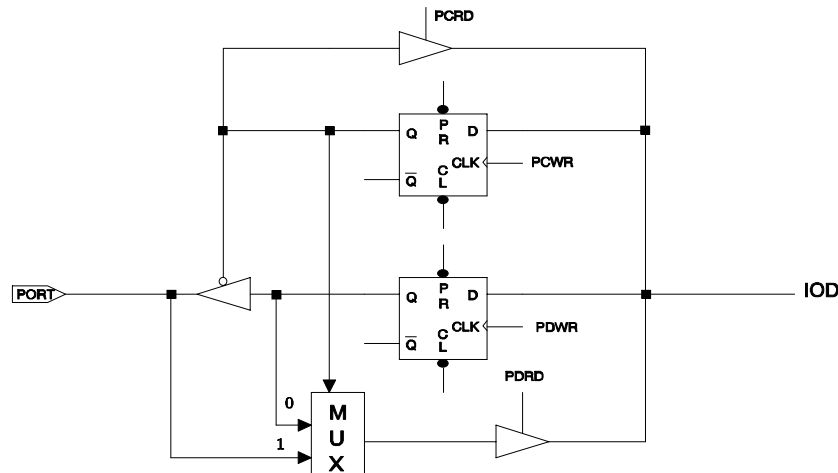

Fig.11 The circuit of I/O port and I/O control register

### VII.5 RESET and Wake-up

The RESET can be caused by

- (1) Power on reset, or Voltage detector
- (2) WDT timeout. (if enabled and in GREEN or NORMAL mode)

Note that only Power on reset, or only Voltage detector in Case(1) is enabled in the system by CODE Option bit. If Voltage detector is disabled, Power on reset is selected in Case (1). Refer to Fig. 12.

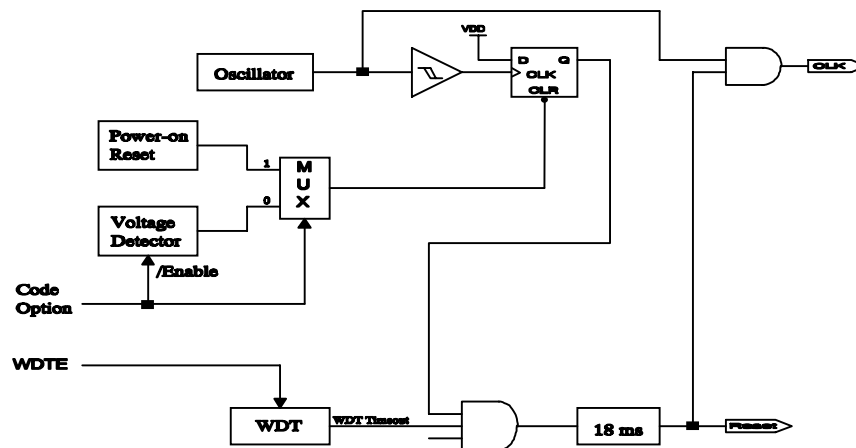

Fig.12 Block diagram of Reset of controller

Once the RESET occurs, the following functions are performed.

- The oscillator is running, or will be started.
- The Program Counter (R2) is set to all "0".

\* This specification are subject to be changed without notice.



- When power on, the upper 3 bits of R3 and the upper 2 bits of R4 are cleared.
- The Watchdog timer and prescaler are cleared.
- The Watchdog timer is disabled.
- The CONT register is set to all "1"
- The other register (bit7..bit0)

R5 = "xxxx0000"	IOC5 = "1111xxxx"	
R6 = PORT	IOC6 = "11111111"	
R7 = PORT	IOC7 = "11111111"	
R8 = PORT	IOC8 = "11111111"	
R9 = PORT	IOC9 = "11111111"	
RA = "00000xxx"	IOCA = "00000000"	
RB = "00000000"	Page0 IOCB = "00000000"	Page1 IOCB = "00000000"
RC = "00000000"	Page0 IOCC = "0xxxxxxx"	Page1 IOCC = "00000000"
RD = "xxxxxxx"	Page0 IOCD = "00000000"	Page1 IOCD = "00000000"
RE = "x0000000"	Page0 IOCE = "00000000"	Page1 IOCE = "00000000"
RF = "00000000"	IOCF = "00000000"	

The controller can be awakened from SLEEP mode or IDLE mode (execution of "SLEP" instruction, named as SLEEP MODE or IDLE mode) by (1)TCC time out (IDLE mode only) (2) WDT time-out (if enabled) or, (3) external input at PORT9 (4)RINGTIME pin. The four cases will cause the controller wake up and run from next instruction in IDLE mode, reset in SLEEP mode. After wake-up, user should control WATCH DOG in case of reset in GREEN mode or NORMAL mode. The last three should be open RE register before into SLEEP mode or IDLE mode. The first one case will set a flag in RF bit0. And it will go to address 0x08 when TCC generate a interrupt.

## VII.6 Interrupt

The CALLER ID IC has internal interrupts which are falling edge triggered, as followed : TCC timer overflow interrupt (internal), two 8-bit counters overflow interrupt.

If these interrupt sources change signal from high to low, then RF register will generate '1' flag to corresponding register if you enable IOCF register.

RF is the interrupt status register which records the interrupt request in flag bit. IOCF is the interrupt mask register. Global interrupt is enabled by ENI instruction and is disabled by DISI instruction. When one of the interrupts (when enabled) generated, will cause the next instruction to be fetched from address 008H. Once in the interrupt service routine the source of the interrupt can be determined by polling the flag bits in the RF register. The interrupt flag bit must be cleared in software before leaving the interrupt service routine and enabling interrupts to avoid recursive interrupts.

There are four external interrupt pins including INT0, INT1, INT2, INT3. And four internal counter interrupt available.

External interrupt INT0, INT1, INT2, INT3 signals are from PORT7 bit0 to bit3. If IOCF is enable then these signal will cause interrupt, or these signals will be treated as general input data.

After reset, the next instruction will be fetched from address 000H and the instruction inturrept is 001H and the hardware inturrept is 008H.

TCC will go to address 0x08 in GREEN mode or NORMAL mode after time out. And it will run next instruction from "SLEP" instruction and then go to address 0x08 in IDLE mode. These two cases will set a RF flag.

## VII.7 Instruction Set

Instruction set has the following features:

- (1). Every bit of any register can be set, cleared, or tested directly.
- (2). The I/O register can be regarded as general register. That is, the same instruction can operates on I/O register.

\* This specification are subject to be changed without notice.



The symbol "R" represents a register designator which specifies which one of the 64 registers (including operational registers and general purpose registers) is to be utilized by the instruction. Bits 6 and 7 in R4 determine the selected register bank. "b" represents a bit field designator which selects the number of the bit, located in the register "R", affected by the operation. "k" represents an 8 or 10-bit constant or literal value.

INSTRUCTION BINARY	HEX	MNEMONIC	OPERATION	STATUS AFFECTED
0 0000 0000 0000	0000	NOP	No Operation	None
0 0000 0000 0001	0001	DAA	Decimal Adjust A	C
0 0000 0000 0010	0002	CONTW	A → CONT	None
0 0000 0000 0011	0003	SLEP	0 → WDT, Stop oscillator	T,P
0 0000 0000 0100	0004	WDTC	0 → WDT	T,P
0 0000 0000 rrrr	000r	IOW R	A → IOCR	None
0 0000 0001 0000	0010	ENI	Enable Interrupt	None
0 0000 0001 0001	0011	DISI	Disable Interrupt	None
0 0000 0001 0010	0012	RET	[Top of Stack] → PC	None
0 0000 0001 0011	0013	RETI	[Top of Stack] → PC Enable Interrupt	None
0 0000 0001 0100	0014	CONTR	CONT → A	None
0 0000 0001 rrrr	001r	IOR R	IOCR → A	None
0 0000 0010 0000	0020	TBL	R2+A → R2 bits 9,10 do not clear	Z,C,DC
0 0000 01rr rrrr	00rr	MOV R,A	A → R	None
0 0000 1000 0000	0080	CLRA	0 → A	Z
0 0000 11rr rrrr	00rr	CLR R	0 → R	Z
0 0001 00rr rrrr	01rr	SUB A,R	R-A → A	Z,C,DC
0 0001 01rr rrrr	01rr	SUB R,A	R-A → R	Z,C,DC
0 0001 10rr rrrr	01rr	DECA R	R-1 → A	Z
0 0001 11rr rrrr	01rr	DEC R	R-1 → R	Z
0 0010 00rr rrrr	02rr	OR A,R	A ∨ VR → A	Z
0 0010 01rr rrrr	02rr	OR R,A	A ∨ VR → R	Z
0 0010 10rr rrrr	02rr	AND A,R	A & R → A	Z
0 0010 11rr rrrr	02rr	AND R,A	A & R → R	Z
0 0011 00rr rrrr	03rr	XOR A,R	A ⊕ R → A	Z
0 0011 01rr rrrr	03rr	XOR R,A	A ⊕ R → R	Z
0 0011 10rr rrrr	03rr	ADD A,R	A + R → A	Z,C,DC
0 0011 11rr rrrr	03rr	ADD R,A	A + R → R	Z,C,DC
0 0100 00rr rrrr	04rr	MOV A,R	R → A	Z
0 0100 01rr rrrr	04rr	MOV R,R	R → R	Z
0 0100 10rr rrrr	04rr	COMA R	/R → A	Z
0 0100 11rr rrrr	04rr	COM R	/R → R	Z
0 0101 00rr rrrr	05rr	INCA R	R+1 → A	Z
0 0101 01rr rrrr	05rr	INC R	R+1 → R	Z
0 0101 10rr rrrr	05rr	DJZA R	R-1 → A, skip if zero	None
0 0101 11rr rrrr	05rr	DJZ R	R-1 → R, skip if zero	None
0 0110 00rr rrrr	06rr	RRCA R	R(n) → A(n-1) R(0) → C, C → A(7)	C
0 0110 01rr rrrr	06rr	RRC R	R(n) → R(n-1) R(0) → C, C → R(7)	C
0 0110 10rr rrrr	06rr	RLCA R	R(n) → A(n+1)	C

\* This specification are subject to be changed without notice.



						R(7) → C, C → A(0)	
0	0110	1rr	rrrr	06rr	RLC R	R(n) → R(n+1) R(7) → C, C → R(0)	C
0	0111	00rr	rrrr	07rr	SWAPA R	R(0-3) → A(4-7) R(4-7) → A(0-3)	None
0	0111	01rr	rrrr	07rr	SWAP R	R(0-3) ↔ R(4-7)	None
0	0111	10rr	rrrr	07rr	JZA R	R+1 → A, skip if zero	None
0	0111	11rr	rrrr	07rr	JZ R	R+1 → R, skip if zero	None
0	100b	bbrr	rrrr	0xxx	BC R,b	0 → R(b)	None
0	101b	bbrr	rrrr	0xxx	BS R,b	1 → R(b)	None
0	110b	bbrr	rrrr	0xxx	JBC R,b	if R(b)=0, skip	None
0	111b	bbrr	rrrr	0xxx	JBS R,b	if R(b)=1, skip	None
1	00kk	kkkk	kkkk	1kkk	CALL k	PC+1 → [SP] (Page, k) → PC	None
1	01kk	kkkk	kkkk	1kkk	JMP k	(Page, k) → PC	None
1	1000	kkkk	kkkk	18kk	MOV A,k	k → A	None
1	1001	kkkk	kkkk	19kk	OR A,k	A ∨ k → A	Z
1	1010	kkkk	kkkk	1Akk	AND A,k	A & k → A	Z
1	1011	kkkk	kkkk	1Bkk	XOR A,k	A ⊕ k → A	Z
1	1100	kkkk	kkkk	1Ckk	RETL k	k → A, [Top of Stack] → PC	None
1	1101	kkkk	kkkk	1Dkk	SUB A,k	k-A → A	Z,C,DC
1	1110	0000	0001	1E01	INT	PC+1 → [SP] 001H → PC	None
1	1110	1000	0kkk	1E8k	PAGE k	K->R5	None
1	1111	kkkk	kkkk	1Fkk	ADD A,k	k+A → A	Z,C,DC

## VII.8 CODE Option Register

The CALLER ID IC has one CODE option register which is not part of the normal program memory. The option bits cannot be accessed during normal program execution.

7	6	5	4	3	2	1	0
-	-	-	-	-	-	/POVD	-

\* Bit 0 : unused, must be "0"s.

\* Bit 1 : (/POVD) : Power on voltage detector.

0: enable

1: disable

/POVD	2.0V POVD reset	1.6V power on reset	2.5V voltage detect no reset	sleep mode current
1	no	yes	no	1uA typical
0	yes	yes	yes	6uA typical

\* Bits 2~7 : unused, must be "0"s.

## VII.9 FSK FUNCTION

### VII.9.1 Functional Block Diagram

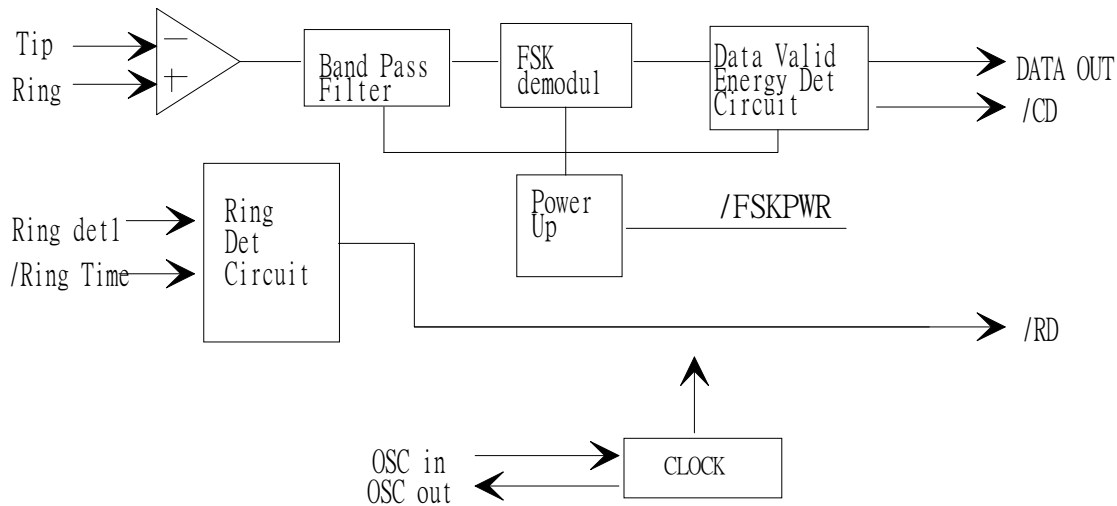

Fig.13 FSK Block Diagram

### VII.9.2 Function Descriptions

The CALLER ID IC is a CMOS device designed to support the Caller Number Deliver feature which is offered by the Regional Bell Operating Companies. The FSK block comprises two paths: the signal path and the ring indicator path. The signal path consist of an input differential buffer, a band pass filter, an FSK demodulator and a data valid with carrier detect circuit. The ring detector path includes a clock generator, a ring detect circuit.

In a typical application, the ring detector maintains the line continuously while all other functions of the chip are inhibited. If a ring signal is sent, the /RINGTIME pin will has a low signal. User can use this signal to wake up whole chip or read /RD signal from RA register.

A /FSKPWR input is provided to activate the block regardless of the presence of a power ring signal. If /FSKPWR is sent low, the FSK block will power down whenever it detects a valid ring signal, it will power on when /FSKPWR is high.

The input buffer accepts a differential AC coupled input signal through the TIP and RING input and feeds this signal to a band pass filter. Once the signal is filtered, the FSK demodulator decodes the information and sends it to a post filter. The output data is then made available at DATA OUT pin. This data, as sent by the central office, includes the header information (alternate "1" and "0") and 150 ms of marking which precedes the date, time and calling number. If no data is present, the DATA OUT pin is held in a high state. This is accomplished by an carrier detect circuit which determines if the in-band energy is high enough. If the incoming signal is valid and thus the demodulated data is transferred to DATA OUT pin. If it is not, then the FSK demodulator is blocked.

### VII.9.3 Ring detect circuit

When Vdd is applied to the circuit, the RC network will charge cap C1 to Vdd holding /RING TIME off. The resistor network R2 to R3 attenuates the incoming power ring applied to the top of R2. The values given have been chosen to provide a sufficient voltage at DET1 pin, to turn on the Schmitt trigger input. When  $V_{t+}$  of the Schmitt is exceeded, cap C1 will discharge.

The value of R1 and C1 must be chosen to hold the /RING TIME pin voltage below the  $V_{t+}$  of the Schmitt between the individual cycle of the power ring. With /RINGTIME enabled, this signal will be a /RD signal in RA through a buffer.

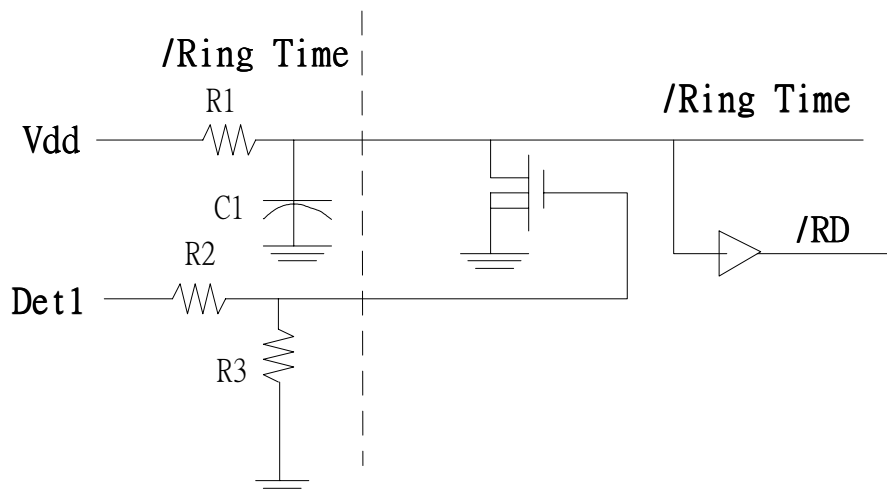

Fig.14 ring detect circuit

## VII.10 DTMF Receiver

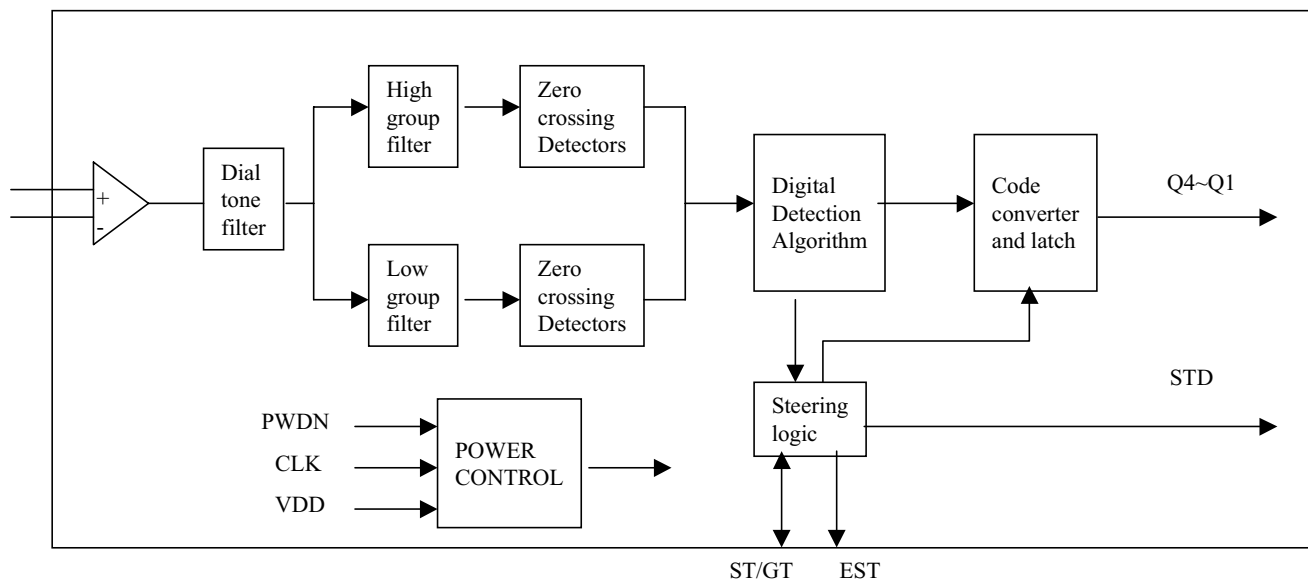

Fig.15 DTMF receiver function Block diagram

The DTMF receiver offers small size, low power consumption and high performance. Its architecture consists of a band split filter section, which separates the high and low tones of receiver pair, followed by a digital counting section which verifies the frequency and duration of the received tones before passing the corresponding code to the output bus.



## FILTER SECTION

Separation of the low-group and high-group tones is achieved by applying the dual tone signal to the inputs of two filters a sixth order for the high group and an eighth order for the low group. The bandwidths of which correspond to the bands enclosing the low-group and high-group tones . The filter section also incorporate notches at 350Hz and 440 Hz for exceptional dial-tone rejection. Each filter output is followed by a second-order switched-capacitor section which smooth the

signals prior to limiting. Limiting is performed by high-gain comparators which are provided with hysteresis to prevent detection of unwanted low-level signals and noise; the outputs of the comparators provide full-rail logic swings at the frequencies of the incoming tones.

F low	F high	Key	PWDN	Q4~Q1
697	1209	1	1	0001
697	1336	2	1	0010
697	1477	3	1	0011
770	1209	4	1	0100
770	1336	5	1	0101
770	1477	6	1	0110
852	1209	7	1	0111
852	1336	8	1	1000
852	1477	9	1	1001
941	1209	0	1	1010
941	1336	*	1	1011
941	1477	#	1	1100
697	1633	A	1	1101
770	1633	B	1	1110
852	1633	C	1	1111
941	1633	D	1	0000
Any	Any	Any	0	XXXX (x:unknown)

## Decoder Section

The decoder used digital counting techniques to determine the frequencies of the limited tones and to verify that they correspond to standard DTMF frequencies. A complex averaging algorithm(protects) against tone simulation by extraneous signals, such as voice, while providing tolerance to small frequency deviations and variations. This averaging algorithm has been developed to ensure an optimum combination of immunity to talk-off? and tolerance to the presence of interfering signals (third tones? and noise. When the detector recognizes the simultaneous presence of two valid tones (referred to as signal condition? in some industry specifications), it raises the early steering flag (EST). Any subsequent loss of signal condition will cause EST to fall.

Before registration of a decoded tone-pair, the receiver checks for a valid signal duration (referred to as character recognition-condition?). This check is per-formed by an external RC time-constant driven by EST. A logic high on EST causes VC to rise as the capacitor discharges. Provided signal-condition is maintained (EST remains high) for the validation period , VC reaches the threshold ( $V_{tst}$ ) of the steering logic to register the tone-pair, latching its corresponding 4-bit code into the output latch.

At this point, the GT output is activated and drives VC to VDD . GT continues to drive high as long as EST remains high. Finally after a short delay to allow the output latch to settle, the delayed-steering? output flag, STD, goes high, signaling that a received tone-pair has been registered. The contents of the output latch are made available on the 4-bit output register .

The steering circuit works in reverse to validate the inter digit pauses between signals. Thus, as well as rejecting signals too short to be considered valid, the receiver will tolerate signal interruptions (drop-out? too short to be considered a valid pause. The facility, together with the capability of selecting the steering time-constants externally, allows the designer to

\* This specification are subject to be changed without notice.

tailor performance to meet a wide variety of system requirements.

### Guard Time Adjustment

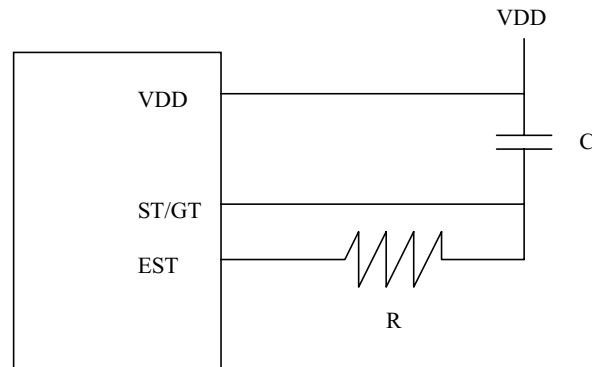

Fig.16 Guard Time

In many situations not requiring independent selection of receive and pause, the simple steering circuit of is applicable. Component values are chosen according to the following formulae:

$$t_{REC} = t_{DP} + t_{GTP} \quad t_{ID} = t_{DA} + t_{GTA}$$

The value of  $t_{DP}$  is a parameter of the device and  $t_{REC}$  is the minimum signal duration to be recognized by the receiver. A value for  $C$  of 0.1  $\mu\text{F}$  is recommended for most applications, leaving  $R$  to be selected by the designer. For example, a suitable value of  $R$  for a  $t_{REC}$  of 30ms would be 300k.

Different steering arrangements may be used to select independently the guard-times for tone-present ( $t_{GTP}$ ) and tone-absent ( $t_{GTA}$ ). This may be necessary to meet system specifications which place both accept and reject limits on both tone duration and inter digital pause.

Guard-time adjustment also allows the designer to tailor system parameters such as talk off and noise immunity. Increasing  $t_{REC}$  improves talk-off performance, since it reduces the probability that tones simulated by speech will maintain signal condition for long enough to be registered. On the other hand, a relatively short  $t_{REC}$  with a long  $t_{DO}$  would be appropriate for extremely noisy environments where fast acquisition time and immunity to drop-outs would be required.

## VII.11 LCD Driver

The CALLER ID IC can drive LCD directly and has 60 segments and 16 commons that can drive 60\*16 dots totally. LCD block is made up of LCD driver, display RAM, segment output pins, common output pins and LCD operating power supply pins.

Duty, bias, the number of segment, the number of common and frame frequency are determined by LCD mode register. LCD control register.

The basic structure contains a timing control which uses the basic frequency 32.768KHz to generate the proper timing for different duty and display access. RE register is a command register for LCD driver, the LCD display( disable, enable, blanking) is controlled by LCD\_C and the driving duty and bias is decided by LCD\_M and the display data is stored in data RAM which address and data access controlled by registers RC and RD.

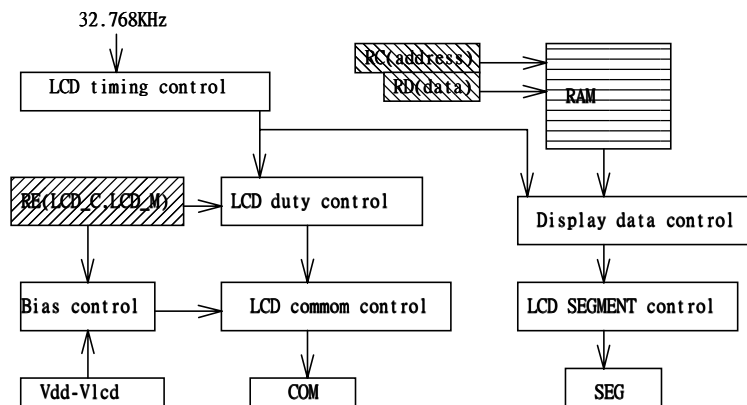

Fig.17 LCD DRIVER CONTROL

### VII.11.1 LCD Driver Control

1. RE(LCD Driver Control)(initial state "00000000")

7	6	5	4	3	2	1	0
-	-	-	-	-	LCD_C2	LCD_C1	LCD_M

\*Bit0 (LCD\_M):LCD\_M decides the methods, including duty, bias, and frame frequency.

\*Bit1~Bit2 (LCD\_C#):LCD\_C# decides the LCD display enable or blanking. change the display duty must set the LCD\_C to "00".

LCD_C2,LCD_C1	LCD Display Control	LCD_M	duty	bias
0 0	change duty Disable(turn off LCD)	0 1	1/16 1/8	1/4 1/4
0 1	Blanking	:	:	:
1 1	LCD display enable	:	:	:

### VII.11.2 LCD display area

The LCD display data is stored in the data RAM . The relation of data area and COM/SEG pin is as below:

COM15 ~ COM8	COM7 ~ COM0	
40H (Bit15 ~ Bit8)	00H (Bit7 ~ Bit0)	SEG0
41H	01H	SEG1
:	:	:
:	:	:
67H	27H	SEG39
:	:	empty
7DH	3DH	empty
7EH	3EH	empty
7FH	3FH	empty

\*IOCB(LCD Display RAM address)

7	6	5	4	3	2	1	0
-	LCDA6	LCDA5	LCDA4	LCDA3	LCDA2	LCDA1	LCDA0

Bit 0 ~ Bit 6 select LCD Display RAM address up to 127.

LCD RAM can be write whether in enable or disable mode and read only in disable mode.

\*IOCC(LCD Display data) : Bit 0 ~ Bit 8 are LCD data.

### VII.11.3 LCD COM and SEG signal

\* COM signal : The number of COM pins varies according to the duty cycle used, as following: in 1/8 duty mode COM8 ~ COM15 must be open. in 1/16 duty mode COM0 ~ COM15 pins must be used.

	COM0	COM1	COM2	COM3	COM4	COM5	COM6	COM7	COM8	..	COM15
1/8	o	o	o	o	o	o	o	o	x	..	x
1/16	o	o	o	o	o	o	o	o	o	..	o

x:open,o:select

\* SEG signal: The 60 segment signal pins are connected to the corresponding display RAM address 00h to 3Bh. The high byte and the low byte bit7 down to bit0 are correlated to COM15 to COM0 respectively .

When a bit of display RAM is 1, a select signal is sent to the corresponding segment pin, and when the bit is 0 , a non-select signal is sent to the corresponding segment pin.

\*COM, SEG and Select/Non-select signal is shown as following:

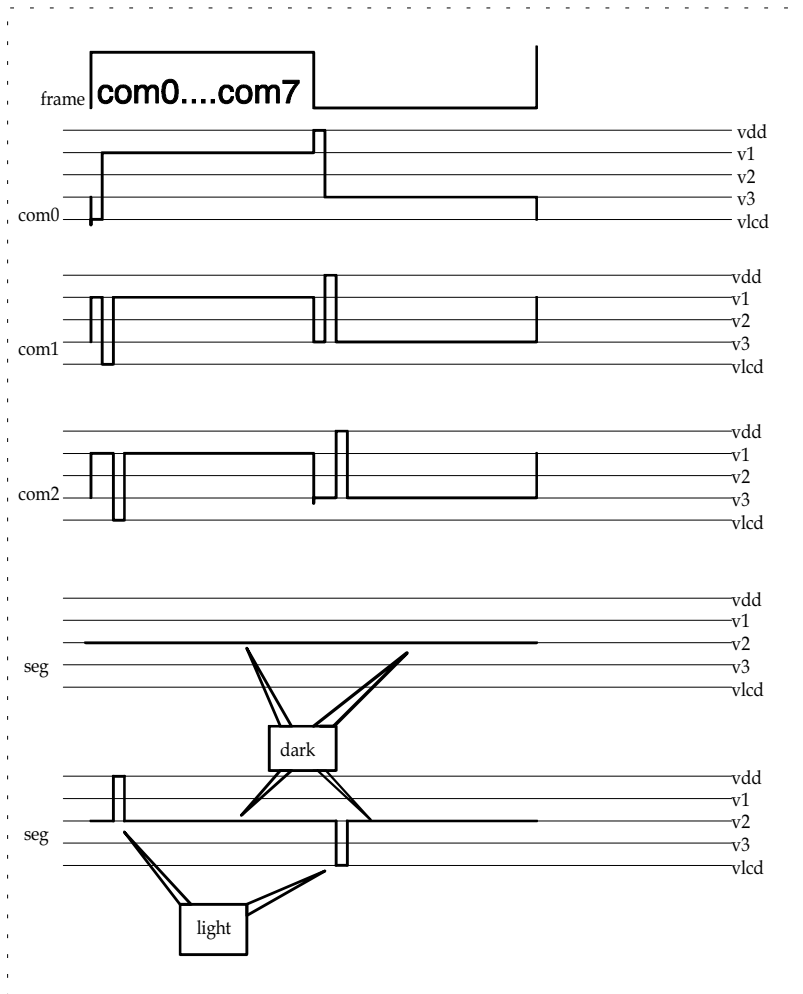

Fig.18 Lcd wave 1/4 bias , 1/8 duty

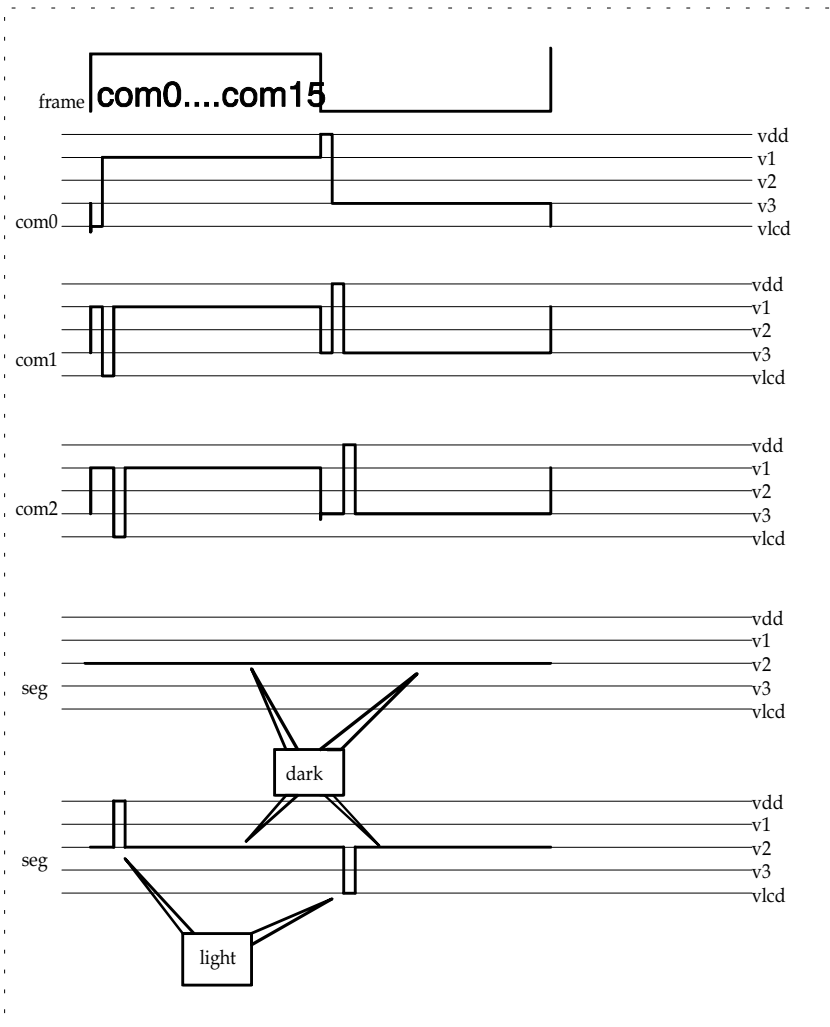

Fig.19 Lcd wave 1/4 bias , 1/16 duty



## VIII. Absolute Operation Maximum Ratings

RATING	SYMBOL	VALUE	UNIT
DC SUPPLY VOLTAGE	Vdd	-0.3 To 3.6	V
INPUT VOLTAGE	Vin	-0.5 TO Vdd +0.5	V
OPERATING TEMPERATURE RANGE	Ta	0 TO 70	°C

## IX DC Electrical Characteristic

(Ta=0°C ~ 70°C, VDD=3.3V±5%, VSS=0V)

Symbol	Parameter	Condition	Min	Typ	Max	Unit
IIL1	Input Leakage Current for input pins	VIN = VDD, VSS			±1	µA
IIL2	Input Leakage Current for bi-directional pins	VIN = VDD, VSS			±1	µA
VIH	Input High Voltage		2.5			V
VIL	Input Low Voltage				0.8	V
VIHT	Input High Threshold Voltage	/RESET, TCC, RDET1	2.0			V
VILT	Input Low Threshold Voltage	/RESET, TCC, RDET1			0.8	V
VIHX	Clock Input High Voltage	OSCI	3.5			V
VILX	Clock Input Low Voltage	OSCI			1.5	V
VHscan	Key scan Input High Voltage	Port6 for key scan	3.5			V
VLscan	Key scan Input Low Voltage	Port6 for key scan			1.5	V
VOH1	Output High Voltage (port6,7,8)	IOH = -1.6mA	2.4			V
	(port9)	IOH = -6.0mA	2.4			V
VOL1	Output Low Voltage (port6,7,8)	IOL = 1.6mA			0.4	V
	(port9)	IOL = 6.0mA			0.4	V
Vcom	Com voltage drop	Io=±/ 50 uA	-	-	2.9	V
Vseg	Segment voltage drop	Io=±/ 50 uA	-	-	3.8	V
Vlcd	LCD drive reference voltage	Contrast adjustment				
IPH	Pull-high current	Pull-high active input pin at VSS		-10	-15	µA
ISB1	Power down current (SLEEP mode) POVD disable	All input and I/O pin at VDD, output pin floating, WDT disabled		1	2	µA
	Power down current (SLEEP mode) POVD enable			6	15	uA
ISB2	Low clock current (GREEN mode) POVD disable	CLK=32.768KHz, FSK, DTMF receiver ,TONE block disable , All input and		30	45	µA
	Low clock current (GREEN mode) POVD enable	I/O pin at VDD, output pin floating, WDT disabled, LCD enable		35	55	uA
ISB3	Low clock current (IDLE mode) POVD disable	CLK=32.768KHz, FSK, DTMF receiver ,TONE block disable , All input and		25	40	µA
	Low clock current	I/O pin at VDD, output pin		30	50	uA

\* This specification are subject to be changed without notice.



	(IDLE mode) POVD enable	floating, WDT disabled, LCD enable				
ICC1	Operating supply current (CPU enable)	/RESET=High, CLK=3.579MHz, output pin floating, FSK, DTMF receiver, TONE block disable		0.8	1.1	mA
ICC2	Operating supply current (CPU and DTMF receiver enable)	/RESET=High, DTMF receiver enable , CLK=3.579MHz, output pin floating, FSK, TONE block disable		2.3	2.6	mA
ICC3	Operating supply current (CPU and FSK enable)	/RESET=High, FSK block enable , CLK=3.579MHz, output pin floating, DTMF receiver and TONE block disable		2.3	2.6	mA
Vref2	Tone generator reference voltage		0.5		0.7	VDD
V1rms	Tone1 signal strength	Root mean square voltage	130	155	180	mV
V2rms	Tone2 signal strength	Root mean square voltage	1.259V1rms			mV

Ps. V1rms and V2rms has 2 dB difference. It means  $20\log(V2rms/V1rms) = 20\log 1.259 = 2$  (dB)

## IX AC Electrical Characteristic

(Ta=0°C ~ 70°C, VDD=3.3V, VSS=0V)

Symbol	Parameter	Conditions	Min	Typ	Max	Unit
Dclk	Input CLK duty cycle		45	50	55	%
Tins	Instruction cycle time	32.768KHz 3.579MHz		60 550		us ns
Tdrh	Device delay hold time			18		ms
Ttcc	TCC input period	Note 1	(Tins+20) /N			ns
Twdt	Watchdog timer period	Ta = 25°C		18		ms

Note 1: N= selected prescaler ratio.

(FSK Band Pass Filter AC Characteristic)(Vdd=+3.3V, Ta=+25°C)

CHARACTERISTIC	MIN	TYP	MAX	UNIT
input sensitivity TIP and RING		-48	--	dBm

(FSK AC Characteristic)

Description	Symbol	Min	Typ	Max	Unit
OSC start up(32.768KHz) (3.579MHz PLL)	Tosc	--		400 10	ms
Carrier detect low	Tcdl	--	10	14	ms
Data out to Carrier det low	Tdoc	--	10	20	ns
Power up low to FSK(setup time)	Tsup	--	15	20	ms
/RD low to Ringtime low	Trd			10	ms
End of FSK to Carrier Detect high	Tcdh	8	--	--	ms
Ringtime low pulse delay	Tpd		1		ms

Please watch out the FSK setup time

(OTP AC Characteristic)

Description	Symbol	Min	Typ	Max	Unit
-------------	--------	-----	-----	-----	------

\* This specification are subject to be changed without notice.



Vpp to VDD level setup time	Trs	2			us
Mode code setup time	Tesu	3			us
Mode code hold time	Tchd	2			us
Data setup time	Tdsu	100			ns
Data hold time	Tdhd	100			ns
Program write pulse width	Tpwd		200		us
Output enable setup time	Toed	300			ns
Data clock pulse width	Tph	100			ns

(DTMF receiver AC Characteristic)

Description	Symbol	Min	Typ	Max	Unit
Tone Present Detection Time	Tdp		Note1		
the guard-times for tone-present (C=0.1uF, R=300K)	Tgtp		30		ms
the guard-times for tone-absent (C=0.1uF, R=300K)	Tgta		30		ms
Propagation Delay (St to Q)	Tpq		8		us
Tone Absent Detection Time	Tda		Note2		ms

Note1: Controlled by software

Note2: Controlled by RC circuit.

## XI. Timing Diagrams

### AC Test Input/Output Waveform

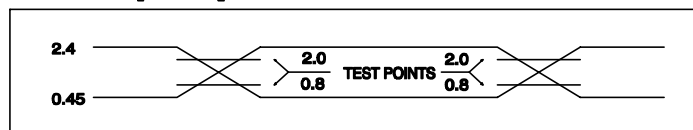

AC Testing: Input are driven at 2.4V for logic "1", and 0.45V for logic "0". Timing measurements are made at 2.0V for logic "1", and 0.8V for logic "0".

### RESET Timing

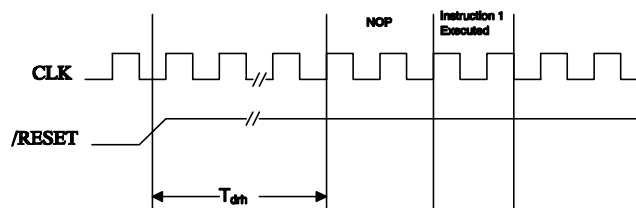

### TCC Input Timing

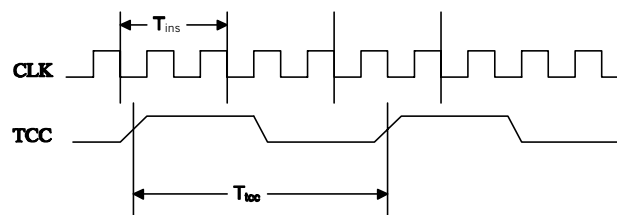

Fig.20 AC timing

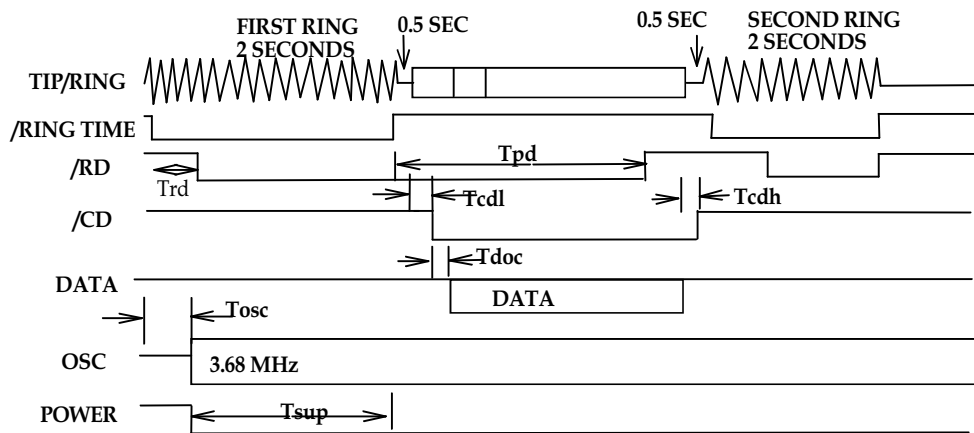

Fig.21 FSK Timing Diagram

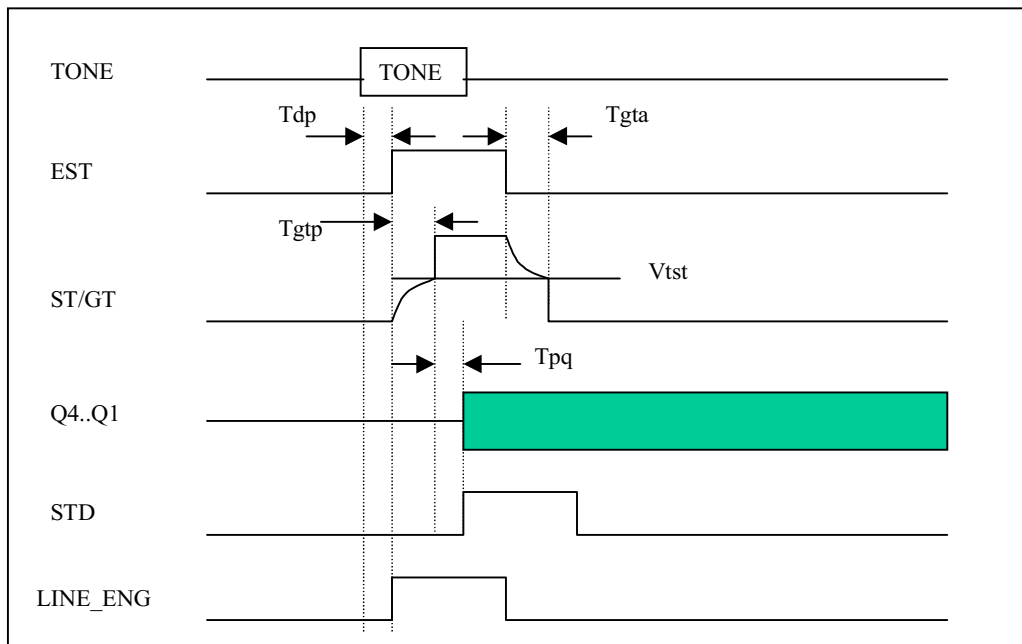

Fig.22. DTMF receiver timing

## XII. Application Circuit

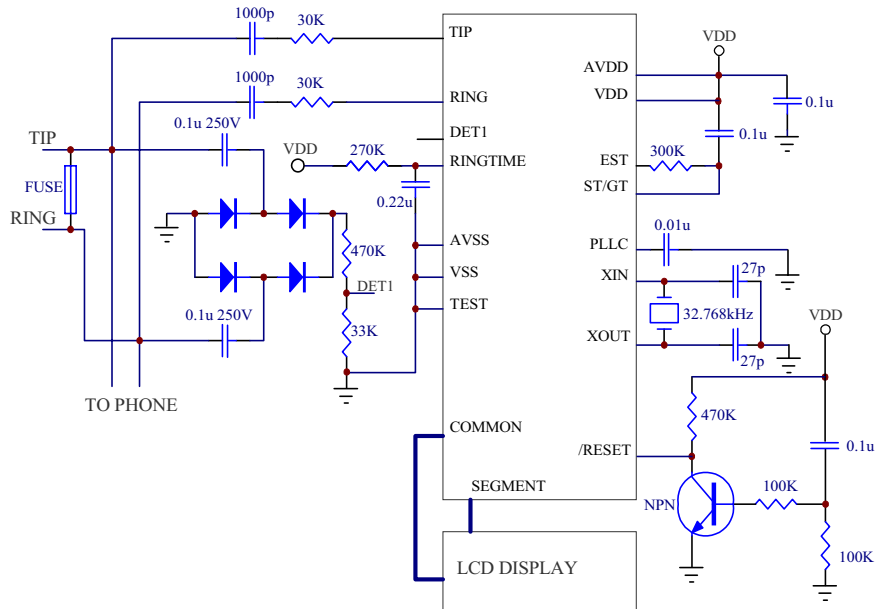

Fig.23.application circuit

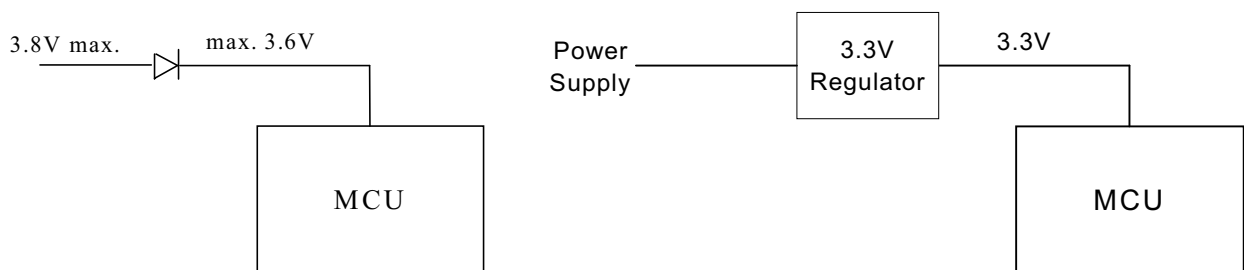

Fig.24 Power Concern in Application