

---

**EM78P468B**

**8-Bit Microcontroller**

**Product  
Specification**

**DOC. VERSION 1.1**

**ELAN MICROELECTRONICS CORP.**

September 2013

---



---

**Trademark Acknowledgments:**

IBM is a registered trademark and PS/2 is a trademark of IBM.

Windows is a trademark of Microsoft Corporation.

ELAN and ELAN logo  are trademarks of ELAN Microelectronics Corporation.

Copyright © 2004~2013 by **ELAN Microelectronics Corporation**

**All Rights Reserved**

Printed in Taiwan, ROC

The contents of in this specification are subject to change without notice. ELAN Microelectronics assumes no responsibility concerning the accuracy, adequacy, or completeness of this specification. ELAN Microelectronics makes no commitment to update, or to keep current the information and material contained in this specification. Such information and material may change to conform to each confirmed order.

In no event shall ELAN Microelectronics be made responsible to any claims attributed to errors, omissions, or other inaccuracies in the information or material contained in this specification. ELAN Microelectronics shall not be liable for direct, indirect, special incidental, or consequential damages arising out of the use of such information or material.

The software (if any) described in this specification is furnished under a license or nondisclosure agreement, and may be used or copied only in accordance with the terms of such agreement.

ELAN Microelectronics products are not intended for use in life support appliances, devices, or systems. Use of ELAN Microelectronics product in such applications is not supported and is prohibited.

NO PART OF THIS SPECIFICATION MAY BE REPRODUCED OR TRANSMITTED IN ANY FORM OR BY ANY MEANS WITHOUT THE EXPRESS WRITTEN PERMISSION OF ELAN MICROELECTRONICS.



---

**ELAN MICROELECTRONICS CORPORATION**

---

**Headquarters:**

No. 12, Innovation Road 1  
Hsinchu Science Park  
Hsinchu, TAIWAN 308  
Tel: +886 3 563-9977  
Fax: +886 3 563-9966  
[webmaster@emc.com.tw](mailto:webmaster@emc.com.tw)  
<http://www.emc.com.tw>

**Hong Kong:**

**Elan (HK) Microelectronics Corporation, Ltd.**  
Flat A, 19F., World Tech Centre  
95 How Ming Street, Kwun Tong  
Kowloon, HONG KONG  
Tel: +852 2723-3376  
Fax: +852 2723-7780  
[elanhk@emc.com.hk](mailto:elanhk@emc.com.hk)

**USA:**

**Elan Information Technology Group (U.S.A.)**  
P.O. Box 601  
Cupertino, CA 95015  
U.S.A.  
Tel: +1 408 366-8225  
Fax: +1 408 366-8225

**Korea:**

**Elan Korea Electronics Company, Ltd.**  
301 Dong-A Building  
632 Kojan-Dong, Namdong-ku  
Incheon City, KOREA  
Tel: +82 32 814-7730  
Fax: +82 32 813-7730

**Shenzhen:**

**Elan Microelectronics Shenzhen, Ltd.**  
8A Floor, Microprofit Building  
Gaoxin South Road 6  
Shenzhen Hi-tech Industrial Park  
South Area, Shenzhen  
CHINA 518057  
Tel: +86 755 2601-0565  
Fax: +86 755 2601-0500  
[elan-sz@elanic.com.cn](mailto:elan-sz@elanic.com.cn)

**Shanghai:**

**Elan Microelectronics Shanghai, Ltd.**  
6F, Ke Yuan Building  
No. 5 Bibo Road  
Zhangjiang Hi-Tech Park  
Shanghai, CHINA 201203  
Tel: +86 21 5080-3866  
Fax: +86 21 5080-0273  
[elan-sh@elanic.com.cn](mailto:elan-sh@elanic.com.cn)

---

# Contents

<b>1</b>	<b>General Description .....</b>	<b>1</b>
<b>2</b>	<b>Features .....</b>	<b>1</b>
<b>3</b>	<b>Pin Assignment .....</b>	<b>2</b>
<b>4</b>	<b>Pin Description .....</b>	<b>5</b>
<b>5</b>	<b>Block Diagram .....</b>	<b>10</b>
<b>6</b>	<b>Functional Description.....</b>	<b>11</b>
6.1	Operational Registers .....	11
6.1.1	R0, IAR (Indirect Addressing Register) .....	11
6.1.2	R1, TCC (Timer Clock Counter) .....	11
6.1.3	R2, PC (Program Counter) .....	11
6.1.4	R3, SR (Status Register) .....	13
6.1.5	R4, RSR (RAM Select Register) .....	14
6.1.6	R5, Port 5 (Port 5 I/O Data and Page of Register Select.....)	14
6.1.7	R6, Port 6 (Port 6 I/O Data Register) .....	14
6.1.8	R7, Port 7 (Port 7 I/O Data Register) .....	15
6.1.9	R8, Port 8 (Port 8 I/O Data Register) .....	15
6.1.10	R9, LCDCR (LCD Control Register).....	15
6.1.11	RA, LCD_ADDR (LCD Address) .....	16
6.1.12	RB, LCD_DB (LCD Data Buffer) .....	16
6.1.13	RC, CNTER (Counter Enable Register) .....	17
6.1.14	RD, SBPCR (System, Booster and PLL Control Register) .....	17
6.1.15	RE, IRCR (IR and Port 5 Setting Control Register).....	20
6.1.16	RF, ISR (Interrupt Status Register).....	21
6.1.17	Address: 10h~3Fh; R10~R3F (General Purpose Register) .....	21
6.2	Special Purpose Registers.....	22
6.2.1	A (Accumulator) .....	22
6.2.2	IOC50, P5CR (Port 5 I/O and Ports 7, 8 for LCD Segment Control Register) .....	22
6.2.3	IOC60, P6CR (Port 6 I/O Control Register) .....	23
6.2.4	IOC70, P7CR (Port 7 I/O Control Register) .....	23
6.2.5	IOC80, P8CR (Port 8 I/O Control Register) .....	23
6.2.6	IOC90, RAM_ADDR (128 Bytes RAM Address) .....	23
6.2.7	IOCA0, RAM_DB (128 Bytes RAM Data Buffer).....	24
6.2.8	IOCB0, CNT1PR (Counter 1 Preset Register) .....	24
6.2.9	IOCC0, CNT2PR (Counter 2 Preset Register).....	24
6.2.10	IOCD0, HPWTPR (High-Pulse Width Timer Preset Register) .....	25
6.2.11	IOCE0, LPWTPR (Low-Pulse Width Timer Preset Register) .....	25
6.2.12	IOCF0, IMR (Interrupt Mask Register) .....	25
6.2.13	IOC61, WUCR (Wake-up and Sink Current of P57/IROUT Control Register) .....	26

6.2.14	IOC71, TCCCR (TCC Control Register).....	26
6.2.15	IOC81, WDTCR (WDT Control Register).....	27
6.2.16	IOC91, CNT12CR (Counters 1, 2 Control Register).....	28
6.2.17	IOCA1, HLPWTCR (High/Low Pulse Width Timer Control Register).....	29
6.2.18	IOCB1, P6PH (Port 6 Pull-high Control Register).....	30
6.2.19	IOCC1, P6OD (Port 6 Open Drain Control Register).....	30
6.2.20	IOCD1, P8PH (Port 8 Pull High Control Register).....	31
6.2.21	IOCE1, P6PL (Port 6 Pull Low Control Register).....	31
6.3	TCC and WDT Prescaler.....	31
6.4	I/O Ports.....	34
6.6	Oscillator.....	39
6.6.1	Oscillator Modes.....	39
6.6.2	Phase Lock Loop (PLL Mode).....	39
6.6.3	Crystal Oscillator/Ceramic Resonators (Crystal).....	40
6.6.4	RC Oscillator Mode with Internal Capacitor.....	41
6.7	Power-on Considerations.....	41
6.7.1	External Power-on Reset Circuit.....	42
6.7.2	Residue-Voltage Protection.....	42
6.8	Interrupt.....	43
6.9	LCD Driver.....	44
6.9.1	R9/LCDCR (LCD Control Register).....	44
6.9.2	RA/LCD_ADDR (LCD Address).....	45
6.9.3	RB/LCD_DB (LCD Data Buffer).....	45
6.9.4	RD/SBPCR (System, Booster and PLL Control Registers).....	46
6.10	Infrared Remote Control Application/PWM Waveform Generation.....	50
6.11	Code Options.....	54
6.12	Instruction Set.....	55
6.13	Timing Diagram.....	58
<b>7</b>	<b>Absolute Maximum Ratings.....</b>	<b>59</b>
<b>8</b>	<b>Electrical Characteristics.....</b>	<b>59</b>
8.1	DC Electrical Characteristics.....	59
8.2	AC Electrical Characteristics.....	61

## APPENDIX

<b>A</b>	<b>Ordering and Manufacturing Information .....</b>	<b>62</b>
<b>B</b>	<b>Package Type .....</b>	<b>63</b>
<b>C</b>	<b>Package Information .....</b>	<b>64</b>
<b>D</b>	<b>EM78P468B Program Pin List.....</b>	<b>69</b>
<b>E</b>	<b>Quality Assurance and Reliability .....</b>	<b>70</b>
	E.1 Address Trap Detect .....	70

### Specification Revision History

Doc. Version	Revision Description	Date
1.0	Preliminary version	2013/05/08
1.1	Modified the Pin Description information	2013/09/27

## 1 General Description

The EM78P468B is an 8-bit microprocessor designed and developed with low-power and high-speed CMOS technology. Integrated onto a single chip are on chip Watchdog Timer (WDT), Data RAM, ROM, Programmable Real Time Clock Counter, Internal/External Interrupt, Power-down mode, LCD driver, Infrared Transmitter function, and tri-state I/O. The series has an on-chip 4K×13-bit Electrical One Time Programmable Read Only Memory (OTP-ROM). The EM78P468B provides multi-protection bits to prevent intrusion of user's OTP memory code. Seven Code option bits are available to meet user's requirements. Special 13 bits customer ID options are provided as well.

With its enhanced OTP-ROM feature, the EM78P468B provides a convenient way of developing and verifying user's programs. Moreover, this OTP device offers the advantages of easy and effective program updates, using development and programming tools. Users can avail of the ELAN Writer to easily program their development code.

## 2 Features

- CPU Configuration
  - 4K×13 bits on-chip OTP-ROM
  - 144 bytes general purpose register
  - 128 bytes on-chip data RAM
  - 272 bytes SRAM
  - 8-level stacks for subroutine nesting
  - Power-on voltage detector provided (1.7±0.1V) for EM78P468B
- I/O Port Configuration
  - Typically, 12 bidirectional tri-state I/O ports.
  - 16 bidirectional tri-state I/O ports shared with LCD segment output pin.
  - Up to 28 bidirectional tri-state I/O ports
- Operating Voltage and Temperature Range: EM78P468B
  - Commercial: 2.1V ~ 5.5V. (at 0°C ~+70°C)
  - Industrial: 2.3V ~ 5.5V. (at -40°C ~+85°C)
- Operating Mode:
  - Normal mode: The CPU is operated on main oscillator frequency (Fm)
  - Green mode: The CPU is operated on sub-oscillator frequency (Fs) and main oscillator (Fm) is stopped
  - Idle mode: CPU idle, LCD display remains working
  - Sleep mode: The whole chip stops working
    - ◆ Input port wake-up function (Port 6, Port 8). Works on Idle and Sleep mode.
    - ◆ Operation speed: DC ~ 10 MHz clock input
    - ◆ Dual clock operation
- Oscillation Mode
  - High frequency oscillator can select among Crystal, RC, or PLL (phase lock loop)
  - Low frequency oscillator can select between Crystal or RC mode
- Peripheral Configuration
  - 8-bit real Time Clock/Counter (TCC)
  - One infrared transmitter/PWM generator function
  - Four sets of 8 bits auto reload down-counting timer can be used as interrupt sources
    - ◆ Counter 1: independent down-counting timer
    - ◆ Counter 2, High Pulse Width Timer (HPWT), and Low Pulse Width Timer (LPWT) shared with IR function.
    - ◆ Programmable free running on-chip Watchdog Timer (WDT). This function can operate in Normal, Green and Idle mode.
- Eight Interrupt Sources: Three External and Five Internal
  - Internal interrupt source: TCC; Counters 1 and 2 High/Low pulse width timer
  - External interrupt source : INT0, INT1 and Pin change wake-up (Port 6 and Port 8)
- LCD Circuit
  - Common driver pins: 4
  - Segment driver pins: 32
  - LCD Bias: 1/3, 1/2 bias
  - LCD Duty: 1/4, 1/3, 1/2 duty
- Package Type:
  - Dice form: 59 pins
  - QFP-64 pin: EM78P468BQ64 (Body 14mm×20mm)
  - LQFP-64 pin: EM78P468BL64 (Body 7mm×7mm)
  - LQFP-44 pin: EM78P468BL44 (Body 10mm×10mm)
  - QFP-44 pin: EM78P468BQ44 (Body 10mm×10mm)
  - QFP-64 pin: EM78P468BQ64B (Body 14mm×14mm)

**Note:** These are Green products which do not contain hazardous substances



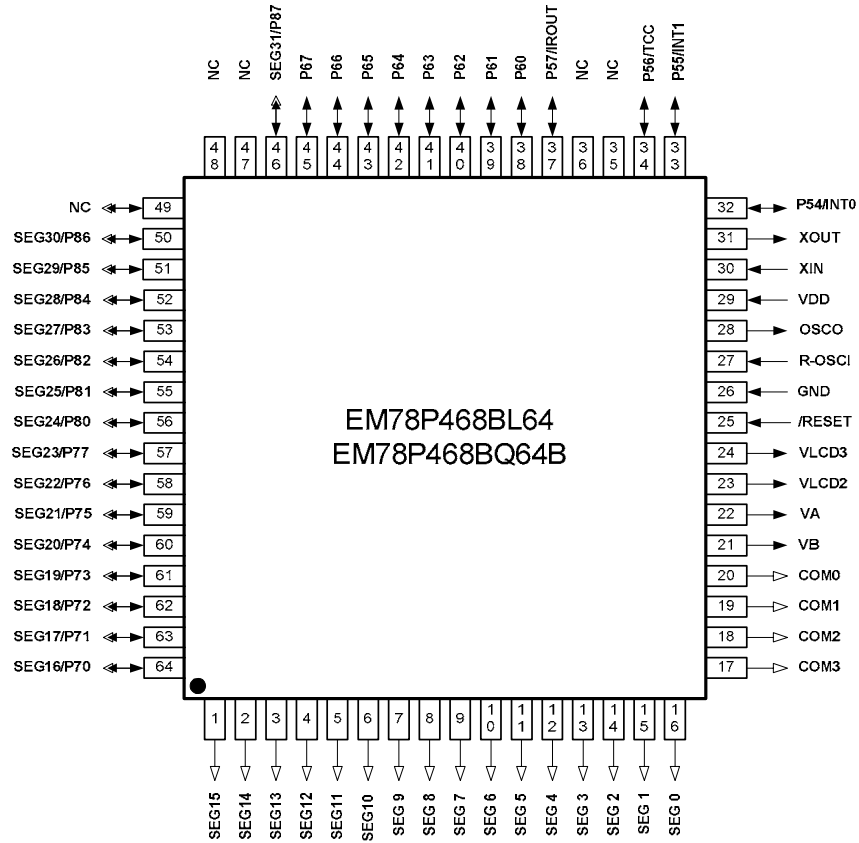

Figure 3-2 64-Pin LQFP/QFP EM78P468BL64/EM78P468BQ64B Pin Assignment

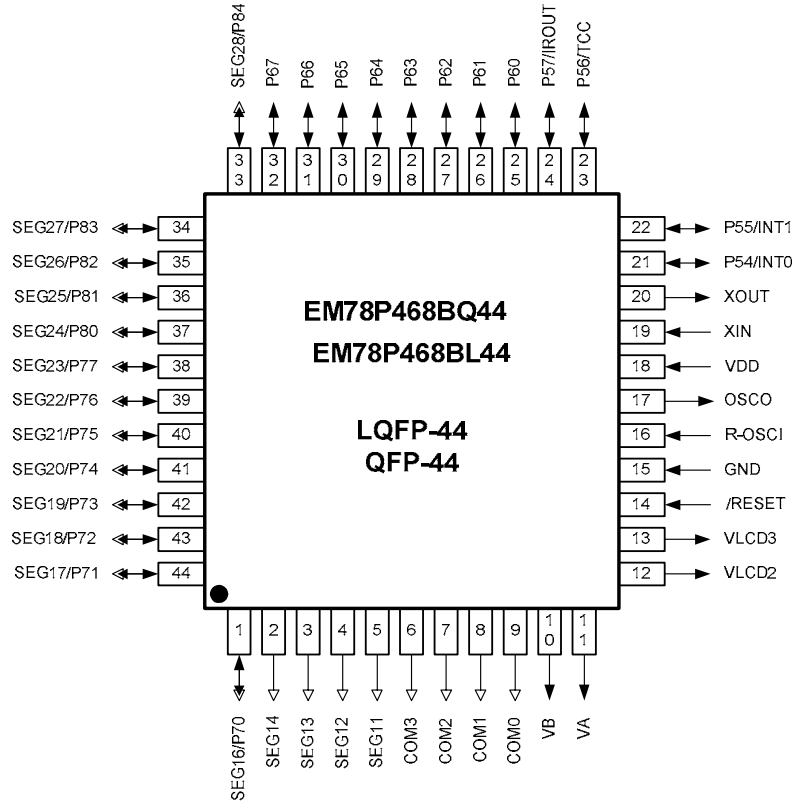
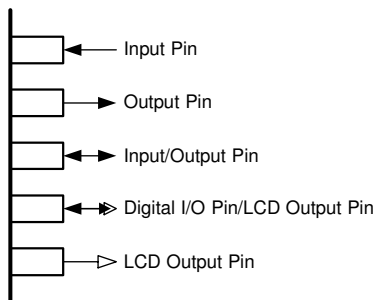

Figure 3-3 44-Pin LQFP/QFP EM78P468BQ44/EM78P468BL44 Pin Assignment



## 4 Pin Description

Symbol	Function	Input Type	Output Type	Description
P54/INT0 (ACLK)	P54	ST	CMOS	Bidirectional I/O pin
	INT0	ST	–	External interrupt pin. The INT0 interrupt source can be set to falling or rising edge by IOC71 register Bit 7 (INT_EDGE). Wakes up from Sleep mode and Idle mode when the pin status changes.
	(ACLK)	ST	–	ACLK pin for Writer programming
P55/INT1 (DINCK)	P55	ST	CMOS	Bidirectional I/O pin
	INT1	ST	–	External interrupt pin The Interrupt source is a falling edge signal. Wakes up from Sleep mode and Idle mode when the pin status changes.
	(DINCK)	ST	–	DINCK pin for Writer programming
P56/TCC (DATAIN)	P56	ST	CMOS	Bidirectional I/O pin. This pin works in Normal/Green/Idle mode.
	TCC	ST	–	TCC External input pin
	(DATAIN)	ST	–	DATAIN pin for Writer programming
P57/IROUT	P57	ST	CMOS	Bidirectional I/O pin. This pin is capable of sinking 20 mA / 5V.
	IROUT	ST	–	IR/PWM mode output pin
P60 (PGMB)	P60	ST	CMOS	Programmable pull-high, pull-down and open-drain. All pins wake up from Sleep and Idle modes when the pin status changes.
	(PGMB)	ST	–	PGMB pin for Writer programming
P61 (OEB)	P61	ST	CMOS	Programmable pull-high, pull-down and open-drain. All pins wake up from Sleep and Idle modes when the pin status changes.
	(OEB)	ST	–	OEB pin for Writer programming
P62	P62	ST	CMOS	Bidirectional I/O pin with programmable pull-high, pull-down and open-drain. All pins wake up from Sleep and Idle modes when the pin status changes.
P63	P63	ST	CMOS	Bidirectional I/O pin with programmable pull-high, pull-down and open-drain. All pins wake up from Sleep and Idle modes when the pin status changes.

Symbol	Function	Input Type	Output Type	Description
P64	P64	ST	CMOS	Bidirectional I/O pin with programmable pull-high, pull-down and open-drain. All pins wake up from Sleep and Idle modes when the pin status changes.
P65	P65	ST	CMOS	Bidirectional I/O pin with programmable pull-high, pull-down and open-drain. All pins wake up from Sleep and Idle modes when the pin status changes.
P66	P66	ST	CMOS	Bidirectional I/O pin with programmable pull-high, pull-down and open-drain. All pins wake up from Sleep and Idle modes when the pin status changes.
P67	P67	ST	CMOS	Bidirectional I/O pin with programmable pull-high, pull-down and open-drain. All pins wake up from Sleep and Idle modes when the pin status changes.
COM3~0	COM3~0	–	AN	LCD common output pin
SEG0~15	SEG0~15	–	AN	LCD segment output pin
SEG16/P70	SEG16	–	AN	LCD segment output pin
	P70	ST	CMOS	Bidirectional I/O pin. All pins wake up from Sleep and Idle modes when the pin status changes.
SEG17/P71	SEG17	–	AN	LCD segment output pin
	P71	ST	CMOS	Bidirectional I/O pin. All pins wake up from Sleep and Idle modes when the pin status changes.
SEG18/P72	SEG18	–	AN	LCD segment output pin
	P73	ST	CMOS	Bidirectional I/O pin. All pins wake up from Sleep and Idle modes when the pin status changes.
SEG19/P73	SEG19	–	AN	LCD segment output pin
	P73	ST	CMOS	Bidirectional I/O pin. All pins wake up from Sleep and Idle modes when the pin status changes.
SEG20/P74	SEG20	–	AN	LCD segment output pin
	P74	ST	CMOS	Bidirectional I/O pin. All pins wake up from Sleep and Idle modes when the pin status changes.
SEG21/P75	SEG21	–	AN	LCD segment output pin
	P75	ST	CMOS	Bidirectional I/O pin. All pins wake up from Sleep and Idle modes when the pin status changes.

Symbol	Function	Input Type	Output Type	Description
SEG22/P76	SEG22	–	AN	LCD segment output pin
	P76	ST	CMOS	Bidirectional I/O pin. All pins wake up from Sleep and Idle modes when the pin status changes.
SEG23/P77	SEG23	–	AN	LCD segment output pin
	P77	ST	CMOS	Bidirectional I/O pin. All pins wake up from Sleep and Idle modes when the pin status changes.
SEG24/P80	SEG24	–	AN	LCD segment output pin
	P80	ST	CMOS	Bidirectional I/O pin with programmable pull-high. All pins wake up from Sleep and Idle modes when the pin status changes.
SEG25/P81	SEG25	–	AN	LCD segment output pin
	P81	ST	CMOS	Bidirectional I/O pin with programmable pull-high. All pins wake up from Sleep and Idle modes when the pin status changes.
SEG26/P82	SEG26	–	AN	LCD segment output pin
	P82	ST	CMOS	Bidirectional I/O pin with programmable pull-high. All pins wake up from Sleep and Idle modes when the pin status changes.
SEG27/P83	SEG27	–	AN	LCD segment output pin
	P83	ST	CMOS	Bidirectional I/O pin with programmable pull-high. All pins wake up from Sleep and Idle modes when the pin status changes.
SEG28/P84	SEG28	–	AN	LCD segment output pin
	P84	ST	CMOS	Bidirectional I/O pin with programmable pull-high. All pins wake up from Sleep and Idle modes when the pin status changes.
SEG29/P85	SEG29	–	AN	LCD segment output pin
	P85	ST	CMOS	Bidirectional I/O pin with programmable pull-high. All pins wake up from Sleep and Idle modes when the pin status changes.
SEG30/P86	SEG30	–	AN	LCD segment output pin
	P86	ST	CMOS	Bidirectional I/O pin with programmable pull-high. All pins wake up from Sleep and Idle modes when the pin status changes.
SEG31/P87	SEG31	–	AN	LCD segment output pin
	P87	ST	CMOS	Bidirectional I/O pin with programmable pull-high. All pins wake up from Sleep and Idle modes when the pin status changes.

Symbol	Function	Input Type	Output Type	Description
VB	VB	–	AN	Connects capacitors for LCD bias voltage
VA	VA	–	AN	Connects capacitors for LCD bias voltage
VLCD2	VLCD2	–	AN	One of LCD bias voltage
VLCD3	VLCD3	–	AN	One of LCD bias voltage
/RESET (VPP)	/RESET	ST	–	General-purpose Input only Low active. If it remains at logic low, the device will reset. /RESET pin for writer programming
	VPP	ST	–	Vpp pin for Writer programming
R-OSCI	R-OSCI	AN	–	In Crystal mode: crystal input In RC mode: resistor pull high In PLL mode: connect a 0.01 $\mu$ F capacitance to GND Connect a 0.01 $\mu$ F capacitor to GND and code option selects PLL mode when high oscillator is not used.
OSCO	OSCO	–	XTAL	In Crystal mode: crystal input In RC mode: instruction clock output
Xin	Xin	XTAL	–	In Crystal mode: Input pin for sub-oscillator. Connect to a 32.768kHz crystal.
Xout	Xout	–	XTAL	In Crystal mode: Connect to a 32.768kHz crystal. In RC mode: instruction clock output
NC	NC	–	–	No connection
VDD	VDD	Power	–	Power
GND	GND	Power	–	Ground

**Legend:** **ST:** Schmitt Trigger input  
**AN:** analog pin

**CMOS:** CMOS output  
**XTAL:** oscillation pin for crystal / resonator

**Pin Status with Enabled Functions**

Pin Function	I/O Status		Pin Control		
	I/O Direction	Pin Change WK/Int.	Pull High	Pull Low	O.D.
General Input	Input	S/W	S/W	S/W	S/W
General Output	Output	Disable	S/W	S/W	S/W
TCC	Input	Disable	S/W	S/W	S/W
LCD Driver	Input	Disable	Disable	Disable	S/W
TC-OUT	Output	Disable	Initial: Enable	S/W	S/W
Reset	Input	Disable	S/W	S/W	S/W
EX_INT	Input	Disable	S/W	S/W	S/W
OSCI	Input	Disable	Disable	Disable	S/W
OSCO	Input	Disable	Disable	Disable	S/W

Disable → It is always disabled

Enable → It is always enabled

S/W → It can be controlled by the register, the initial value is disabled.

1. If the pin is not working as general I/O, it is a must to disable the Pin Change Wake-up/Interrupt function.
2. Priority: digital function output > digital function input > general I/O

## 5 Block Diagram

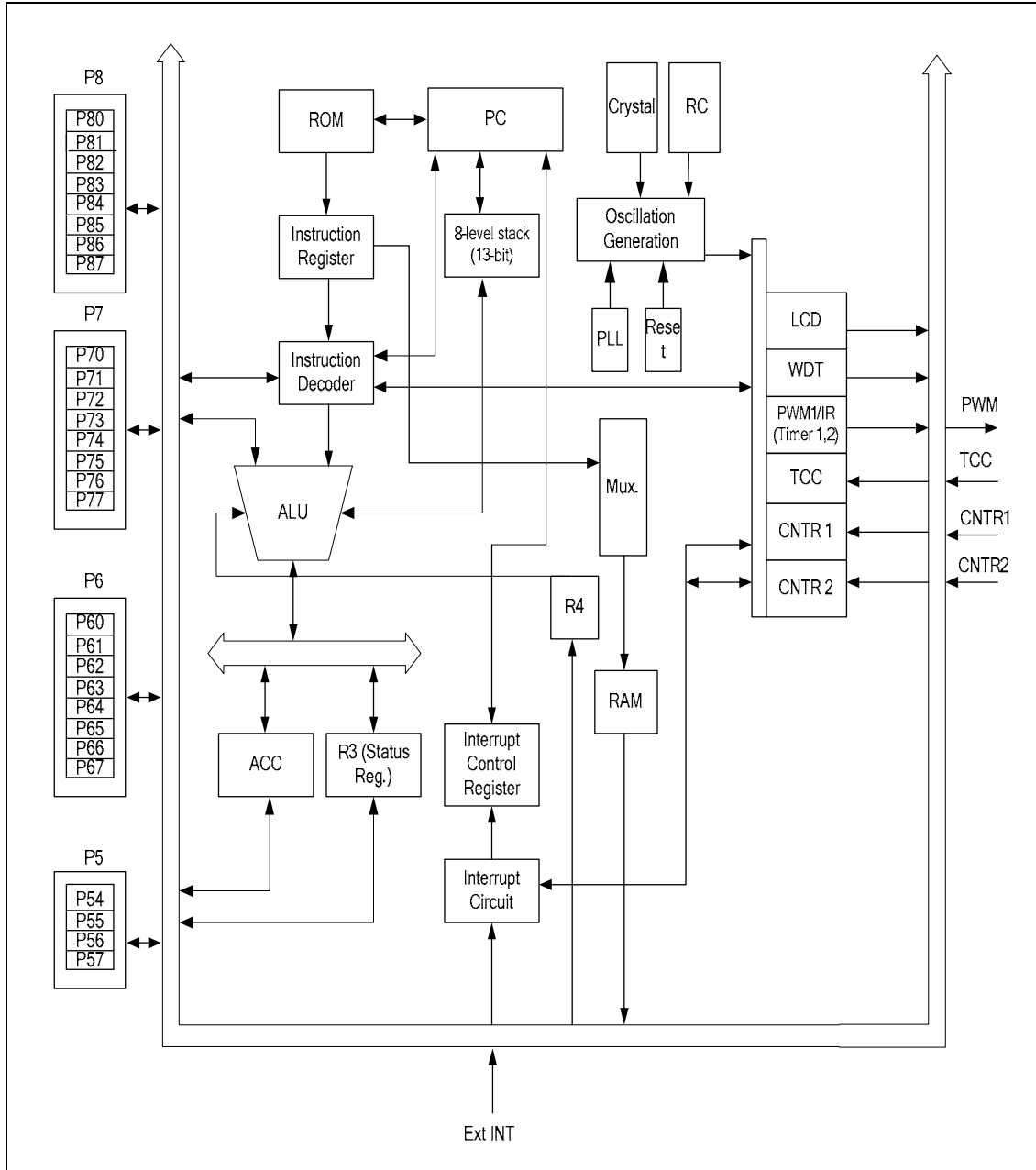

Figure 5 System Block Diagram

## 6 Functional Description

### 6.1 Operational Registers

#### 6.1.1 R0, IAR (Indirect Addressing Register)

(Address: 00h)

R0 is not a physically implemented register. Its major function is to perform as an indirect address pointer. Any instruction using R0 as a register, actually accesses the data pointed by the RAM Select Register (R4).

#### 6.1.2 R1, TCC (Timer Clock Counter)

(Address: 01h)

The Timer Clock Counter is incremented by an external signal edge applied to TCC, or by the instruction cycle clock. It is written and read by the program as any other register.

#### 6.1.3 R2, PC (Program Counter)

(Address: 02h)

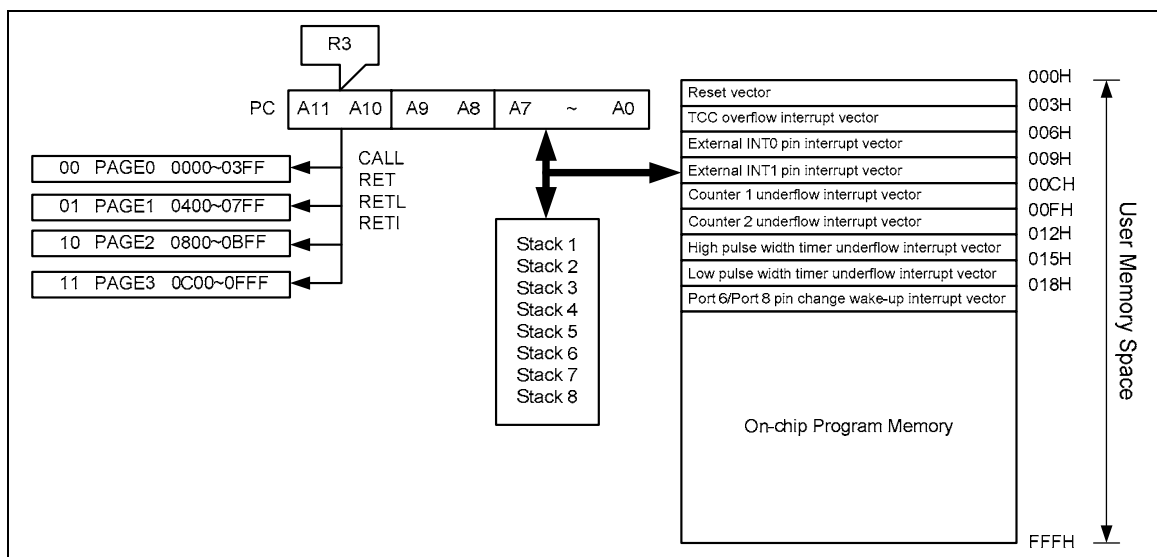

Figure 6-1 Program Counter Organization

- The structure of R2 is depicted in Figure 6-1, *Program Counter Organization*.
- The configuration structure generates 4K×13 bits on-chip ROM addresses to the relative programming instruction codes.
- The contents of R2 are all set to "0"s when a Reset condition occurs.
- "JMP" instruction allows direct loading of the lower 10 program counter bits. Thus, "JMP" allows the PC to jump to any location within a page.



- "CALL" instruction loads the lower 10 bits of the PC, and PC+1 are pushed onto the stack. Thus, the subroutine entry address can be located anywhere within a page.
- "RET" ("RETL k", "RETI") instruction loads the program counter with the contents at the top of the stack.
- "ADD R2, A" allows a relative address to be added to the current PC, and the ninth and above bits of the PC will increment progressively.
- "MOV R2, A" allows loading of an address from the "A" register to the lower 8 bits of the PC, and the ninth and tenth bits (A8 ~ A9) of the PC will remain unchanged.
- The most significant bits (A10~A11) will be loaded with the content of PS0~PS1 in the Status register (R3) upon execution of a "JMP" or "CALL" instruction.

ADDRESS	SBANK0	IOCPAGE0	IOCPAGE1	
00	R0			
01	R1 (TCC)			
02	R2 (PC)			
03	R3 (Status & ROM page)			
04	R4 (RAM selection)			
05	R5 (Port 5 & IOC page)	IOC50 (Port 5 IO control)	IOC51 (unused)	
06	R6 (Port 6)	IOC60 (Port 6 IO control)	IOC61 (Wake-up register)	
07	R7 (Port 7)	IOC 70 (Port 7 IO control)	IOC71 (TCC control)	
08	R8 (Port 8)	IOC80 (Port 8 IO control)	IOC81 (WDT control)	
09	R9 (LCD control)	IOC90 (RAM Address)	IOC91 (CNT1/2 control)	
0A	RA (LCD contrast & addr.)	IOCA0 (RAM Data)	IOCA1 (H/L pulse time control)	
0B	RB (LCD data)	IOCB0 (CNT1 preset)	IOCB1 (Port 6 pull-high)	
0C	RC (Counter enable reg.)	IOCC0 (CNT2 preset)	IOCC1 (Port 6 open-drain)	
0D	RD (System Clock control)	IOCD0 (High pulse timer preset)	IOCD1 (Port 8 pull-high)	
0E	RE (IR control)	IOCE0 (Low pulse timer preset)	IOCE1 (Port 6 pull down)	
0F	RF (Interrupt status)	IOCF0 (interrupt mask )	IOCF1 (unused)	
10   1F	16 byte common register			
20   3F	Bank 0 32 byte common register	Bank 1 32 byte common register	Bank 2 32 byte common register	Bank 3 32 byte common register

Figure 6-2 Data Memory Configuration

### 6.1.4 R3, SR (Status Register)

(Address: 03h)

Bit 7	Bit 6	Bit 5	Bit 4	Bit 3	Bit 2	Bit 1	Bit 0
–	PS1	PS0	T	P	Z	DC	C
	R/W	R/W	R/W	R/W	R/W	R/W	R/W

**Bit 7:** Not used

**Bits 6 ~ 5 (PS1 ~ 0):** Page Select bits

PS1	PS0	ROM Page (Address)
0	0	Page 0 (000H ~ 3FFH)
0	1	Page 1 (400H ~ 7FFH)
1	0	Page 2 (800H ~ BFFH)
1	1	Page 3 (C00H ~ FFFH)

PS0~PS1 are used to select a ROM page. User can use the PAGE instruction (e.g. PAGE 1) or set PS1~PS0 bits to change the ROM page. When executing a "JMP", "CALL", or other instructions which causes the program counter to be changed (e.g. MOV R2, A), PS0~PS1 are loaded into the 11th and 12th bits of the program counter where it selects one of the available program memory pages. Note that RET (RETL, RETI) instruction does not change the PS0~PS1 bits. That is, the return will always be to the page from where the subroutine was called, regardless of the current setting of PS0~PS1 bits.

**Bit 4 (T):** Time-out bit. Set to "1" by the "SLEP" and "WDTC" commands or during power up and reset to "0" by WDT timeout.

Event	T	P	Remark
WDT wake up from sleep mode	0	0	–
WDT time out (not sleep mode)	0	1	–
/RESET wake up from sleep	1	0	–
Power up	1	1	–
Low pulse on /RESET	1	1	x: don't care

**Bit 3 (P):** Power down bit. Set to "1" during power on or by a "WDTC" command and reset to "0" by a "SLEP" command.

**Bit 2 (Z):** Zero flag

**Bit 1 (DC):** Auxiliary Carry flag

**Bit 0 (C):** Carry flag

### 6.1.5 R4, RSR (RAM Select Register)

(Address: 04h)

Bit 7	Bit 6	Bit 5	Bit 4	Bit 3	Bit 2	Bit 1	Bit 0
RBS1	RBS0	RSR5	RSR4	RSR3	RSR2	RSR1	RSR0
R/W	R/W	R/W	R/W	R/W	R/W	R/W	R/W

**Bits 7 ~ 6 (RBS1 ~ RBS0):** determine which bank is activated among the four banks. See the data memory configuration in Figure 6-2. Use the Bank Instruction (e.g. Bank 1) to change banks.

**Bits 5 ~ 0 (RSR5 ~ RSR0):** used to select up to 64 registers (Address: 00~3F) in indirect addressing mode. If no indirect addressing is used, the RSR can be used as an 8-bit general purpose read/writer register.

### 6.1.6 R5, Port 5 (Port 5 I/O Data and Page of Register Select

(Address: 05h)

Bit 7	Bit 6	Bit 5	Bit 4	Bit 3	Bit 2	Bit 1	Bit 0
R57	R56	R55	R54	-	-	-	IOCPAGE
R/W	R/W	R/W	R/W	-	-	-	R/W

**Bits 7~4:** Four bits I/O registers of Port 5

User can use the IOC50 register to define each bit either as input or output.

**Bits 3~1:** Not used

**Bit 0 (IOCPAGE):** change IOC5 ~ IOC F to another page

**IOCPAGE = "0"** : Page 0 (select register of IOC50 to IOC F0)

**IOCPAGE = "1"** : Page 1 (select register of IOC61 to IOC E1)

### 6.1.7 R6, Port 6 (Port 6 I/O Data Register)

(Address: 06h)

Bit 7	Bit 6	Bit 5	Bit 4	Bit 3	Bit 2	Bit 1	Bit 0
R67	R66	R65	R64	R63	R62	R61	R60
R/W	R/W	R/W	R/W	R/W	R/W	R/W	R/W

**Bits 7~0:** 8-bit I/O registers of Port 6

User can use the IOC60 register to define each bit either as input or output.

### 6.1.8 R7, Port 7 (Port 7 I/O Data Register)

(Address: 07h)

Bit 7	Bit 6	Bit 5	Bit 4	Bit 3	Bit 2	Bit 1	Bit 0
R77	R76	R75	R74	R73	R72	R71	R70
R/W	R/W	R/W	R/W	R/W	R/W	R/W	R/W

**Bits 7~0:** 8-bit I/O registers of Port 7

User can use the IOC70 register to define each bit either as input or output.

### 6.1.9 R8, Port 8 (Port 8 I/O Data Register)

(Address: 08h)

Bit 7	Bit 6	Bit 5	Bit 4	Bit 3	Bit 2	Bit 1	Bit 0
R87	R86	R85	R84	R83	R82	R81	R80
R/W	R/W	R/W	R/W	R/W	R/W	R/W	R/W

**Bits 7~0:** 8-bit I/O registers of Port 8

User can use the IOC80 register to define each bit either as input or output.

### 6.1.10 R9, LCDCR (LCD Control Register)

(Address: 09h)

Bit 7	Bit 6	Bit 5	Bit 4	Bit 3	Bit 2	Bit 1	Bit 0
BS	DS1	DS0	LCDEN	-	LCDTYPE	LCDF1	LCDF0
R/W	R/W	R/W	R/W	-	R/W	R/W	R/W

**Bit 7 (BS):** LCD bias select bit

**BS = "0":** 1/2 bias

**BS = "1":** 1/3 bias

**Bit 6 ~ 5 (DS1 ~ DS0):** LCD duty select

DS1	DS0	LCD Duty
0	0	1/2 duty
0	1	1/3 duty
1	×	1/4 duty

**Bit 4 (LCDEN):** LCD enable bit

**LCDEN = "0":** LCD circuit disabled. All common/segment outputs are set to ground (GND) level.

**LCDEN = "1":** LCD circuit enabled.

**Bit 3:** Not used

**Bit 2 (LCDTYPE):** LCD drive waveform type select bit

LCDTYPE = "0": A type waveform

LCDTYPE = "1": B type waveform

**Bits 1 ~ 0 (LCDF1~LCDF0):** LCD frame frequency control bits

LCDF1	LCDF0	LCD Frame Frequency (e.g. Fs=32.768kHz)		
		1/2 Duty	1/3 Duty	1/4 Duty
0	0	$Fs/(256 \times 2)=64.0$	$Fs/(172 \times 3)=63.5$	$Fs/(128 \times 4)=64.0$
0	1	$Fs/(280 \times 2)=58.5$	$Fs/(188 \times 3)=58.0$	$Fs/(140 \times 4)=58.5$
1	0	$Fs/(304 \times 2)=53.9$	$Fs/(204 \times 3)=53.5$	$Fs/(152 \times 4)=53.9$
1	1	$Fs/(232 \times 2)=70.6$	$Fs/(156 \times 3)=70.0$	$Fs/(116 \times 4)=70.6$

*Note:* Fs: sub-oscillator frequency

### 6.1.11 RA, LCD\_ADDR (LCD Address)

(Address: 0Ah)

Bit 7	Bit 6	Bit 5	Bit 4	Bit 3	Bit 2	Bit 1	Bit 0
-	-	-	LCD_A4	LCD_A3	LCD_A2	LCD_A1	LCD_A0
-	-	-	R/W	R/W	R/W	R/W	R/W

**Bits 7~5:** Not used, fixed at "0"

**Bits 4~0 (LCDA4 ~ LCDA0):** LCD RAM addresses

RA (LCD Address)	RB (LCD Data Buffer)					Segment
	Bits 7 ~4	Bit 3 (LCD_D3)	Bit 2 (LCD_D2)	Bit 1 (LCD_D1)	Bit 0 (LCD_D0)	
00H	-	-	-	-	-	SEG0
01H	-	-	-	-	-	SEG1
02H	-	-	-	-	-	SEG2
1DH	-	-	-	-	-	SEG29
1EH	-	-	-	-	-	SEG30
1FH	-	-	-	-	-	SEG31
Common	×	COM3	COM2	COM1	COM0	

### 6.1.12 RB, LCD\_DB (LCD Data Buffer)

(Address: 0Bh)

Bit 7	Bit 6	Bit 5	Bit 4	Bit 3	Bit 2	Bit 1	Bit 0
-	-	-	-	LCD_D3	LCD_D2	LCD_D1	LCD_D0
-	-	-	-	R/W	R/W	R/W	R/W

**Bits 7~4:** Not used

**Bits 3~0 (LCD\_D3 ~ LCD\_D0):** LCD RAM data transfer register

### 6.1.13 RC, CNTER (Counter Enable Register)

(Address: 0Ch)

Bit 7	Bit 6	Bit 5	Bit 4	Bit 3	Bit 2	Bit 1	Bit 0
–	–	–	–	LPWTEN	HPWTEN	CNT2EN	CNT1EN
–	–	–	–	R/W	R/W	R/W	R/W

**Bits 7, 5:** Not used, must be fixed to “0”

**Bits 6, 4:** Not used

**Bit 3 (LPWTEN):** Low pulse width timer enable bit

**LPWTEN = “0”:** Disable LPWT. Stop counting operation.

**LPWTEN = “1”:** Enable LPWT. Start counting operation.

**Bit 2 (HPWTEN):** High pulse width timer enable bit

**HPWTEN = “0”:** Disable HPWT. Stop counting operation.

**HPWTEN = “1”:** Enable HPWT. Start counting operation.

**Bit 1 (CNT2EN):** Counter 2 enable bit

**CNT2EN = “0”:** Disable Counter 2. Stop counting operation.

**CNT2EN = “1”:** Enable Counter 2. Start counting operation.

**Bit 0 (CNT1EN):** Counter 1 enable bit

**CNT1EN = “0”:** Disable Counter 1. Stop counting operation.

**CNT1EN = “1”:** Enable Counter 1. Start counting operation.

### 6.1.14 RD, SBPCR (System, Booster and PLL Control Register)

(Address: 0Dh)

Bit 7	Bit 6	Bit 5	Bit 4	Bit 3	Bit 2	Bit 1	Bit 0
–	CLK2	CLK1	CLK0	IDLE	BF1	BF0	CPUS
–	R/W	R/W	R/W	R/W	R/W	R/W	R/W

**Bit 7:** Not used

**Bits 6 ~ 4 (CLK2 ~ CLK0):** Main clock select bits for PLL mode (Code Option Select)

CLK2	CLK1	CLK0	Main clock	Example Fs=32.768K
0	0	0	Fs×130	4.26 MHz
0	0	1	Fs×65	2.13 MHz
0	1	0	Fs×65/2	1.065 MHz
0	1	1	Fs×65/4	532 kHz
1	×	×	Fs×244	8 MHz

**Bit 3 (IDLE):** Idle mode enable bit. This bit will determine the intended mode of the SLEP instruction.

Idle = "0"+SLEP instruction → Sleep mode

Idle = "1"+SLEP instruction → Idle mode

**\* NOP instruction must be added after SLEP instruction.**

**Example:** Idle mode: Idle bit = "1" +SLEP instruction + NOP instruction

Sleep mode: Idle bit = "0" +SLEP instruction + NOP instruction

**Bits 2, 1 (BF1, 0):** LCD booster frequency select bit to adjust VLCD 2, 3 driving.

BF1	BF0	Booster Frequency
0	0	Fs
0	1	Fs/4
1	0	Fs/8
1	1	Fs/16

**Bit 0 (CPUS):** CPU oscillator source select. When CPUS=0, the CPU oscillator select sub-oscillator and the main oscillator is stopped.

CPUS = "0": sub-oscillator (Fs)

CPUS = "1": main oscillator (Fm)

■ CPU Operation Mode

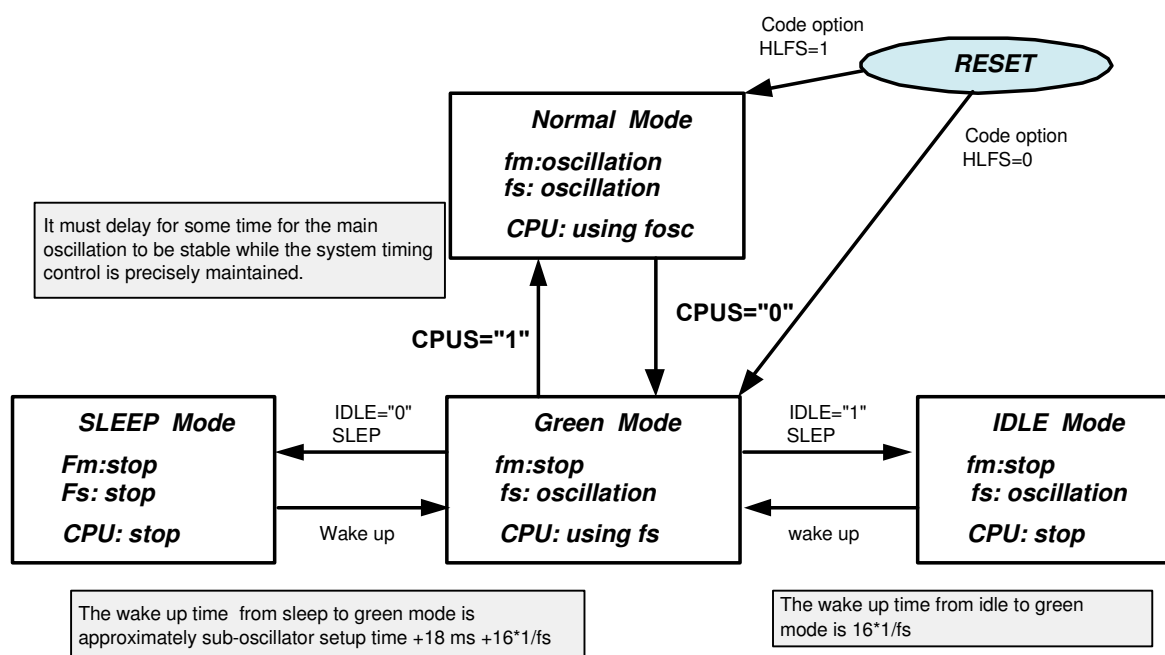

Figure 6-3 CPU Operation Mode

**Note**

(\*) *If the Watchdog function is enabled before going into Sleep mode, some circuits like the Timer (its Clock Source is Fs) must stop counting.*

*If the Watchdog function is enabled before going into Sleep mode, some circuits like the Timer (its Clock Source is the external pin) can still count and its interrupt flag can be active at matching condition as corresponding interrupt is enabled. But the CPU cannot be awakened by this event.*

(\*\*)

**Switching Operation Mode at Sleep → Normal, Green → Normal:**

*If the Timer Clock Source is Fm, the Timer/Counter must stop counting at Sleep or Green mode. Then, the Timer can continue to count until the Clock Source is stable at Normal mode. That the Clock Source is stable means the CPU starts to work at Normal mode.*

**Switching Operation Mode at Sleep → Green:**

*If the Timer Clock Source is Fs, the Timer must stop counting at Sleep mode. Then, the Timer can continue to count until the Clock Source is stable at Green mode. That the Clock Source is stable means the CPU starts to work at Green mode.*

**Switching Operation Mode at Sleep → Normal:**

*If the Timer Clock Source is Fs, the Timer must stop counting at Sleep mode. Then, the Timer can continue to count until the Clock Source is stable at Normal mode. That the Clock Source is stable means the CPU starts to work at Normal mode.*

Fmain	Fsub	Power-on LVR	Pin-Reset WDT	
			N / G / I	S
RC	RC	18ms+WSTO+15*1/Fsub	18ms+WSTO+15*1/ Fsub	18ms+WSTO+15*1/ Fsub
	XT	18ms+WSTO+15*1/Fsub	18ms+WSTO+15*1/ Fsub	18ms+WSTO+15*1/ Fsub
XT	RC	18ms+WSTO+15*1/Fsub	18ms+WSTO+15*1/ Fsub	18ms+WSTO+15*1/ Fsub
	XT	18ms+WSTO+15*1/Fsub	18ms+WSTO+15*1/Fsub	18ms+WSTO+15*1/Fsub

Fmain	Fsub	G → N	I → N	S → N
RC	RC	WSTO + 11*1/Fmain	WSTO + 15*1/ Fsub	18ms + WSTO + 15*1/ Fsub
	XT	WSTO + 11*1/Fmain	WSTO + 15*1/ Fsub	18ms + WSTO + 15*1/ Fsub
XT	RC	WSTO + 11*1/Fmain	WSTO + 15*1/ Fsub	18ms + WSTO + 15*1/ Fsub
	XT	WSTO + 11*1/Fmain	WSTO + 15*1/ Fsub	18ms + WSTO + 15*1/Fsub

Fmain	Fsub	I → G	S → G
IRC	IRC	WSTO + 15*1/Fsub	18ms + WSTO + 15*1/ Fsub
	XT	WSTO + 15*1/Fsub	18ms + WSTO + 15*1/ Fsub
XT	IRC	WSTO + 15*1/Fsub	18ms + WSTO + 15*1/ Fsub
	XT	WSTO + 15*1/Fsub	18ms + WSTO + 15*1/Fsub

**WSTO:** Waiting Time from Start-to-Oscillation

**N:** Normal mode      **G:** Green mode      **I:** Idle mode      **S:** Sleep mode

### 6.1.15 RE, IRCR (IR and Port 5 Setting Control Register)

(Address: 0Eh)

Bit 7	Bit 6	Bit 5	Bit 4	Bit 3	Bit 2	Bit 1	Bit 0
IRE	HF	LGP	–	IROUTE	TCCE	EINT1	EINT0
R/W	R/W	R/W	-	R/W	R/W	R/W	R/W

**Bit 7 (IRE):** Infrared Remote Enable bit

**IRE = "0":** Disable the IR/PWM function. The state of P57/IROUT pin is determined by Bit 7 of IOC 50 if it is for IROUT.

**IRE = "1":** Enable IR or PWM function

**Bit 6 (HF):** High carry frequency

**HF = "0":** For PWM application, disable the H/W modulator function. The IROUT waveform is generated according to high-pulse and low-pulse time as determined by the respective high pulse and low pulse width timers. Counter 2 is an independent auto reload timer.

**HF = "1":** For IR application mode, enable the H/W modulator function, the low time sections of the generated pulse is modulated with the Fcarrier frequency. The Fcarrier frequency is provided by Counter 2.

**Bit 5 (LGP):** IROUT for of low pulse width timer

**LGP = "0":** The high-pulse width timer register and low-pulse width timer is valid.

**LGP = "1":** The high-pulse width timer register is ignored. So the IROUT waveform is dependent on the low-pulse width timer register only.

**Bit 4:** Not used

**Bit 3 (IROUTE):** Define the function of P57/IROUT pin

**IROUTE = "0":** for bidirectional general I/O pin

**IROUTE = "1":** for IR or PWM output pin, the control bit of P57 (Bit 7 of IOC50) must be set to "0"

**Bit 2 (TCCE):** Define the function of P56/TCC pin

**TCCE = "0":** for bidirectional general I/O pin

**TCCE = "1":** for external input pin of TCC, the control bit of P56 (Bit 6 of IOC50) must be set to "1"

**Bit 1 (EINT1):** Define the function of P55/INT1 pin

**EINT1 = "0":** for bidirectional general I/O pin

**EINT1 = "1":** for external interrupt pin of INT1, the control bit of P55 (Bit 5 of IOC50) must be set to "1"

**Bit 0 (EINT0):** Define the function of P54/INT0 pin

**EINT0 = "0":** for bidirectional general I/O pin

**EINT0 = "1":** for external interrupt pin of INT0, the control bit of P54 (Bit 4 of IOC50) must be set to "1"

### **6.1.16 RF, ISR (Interrupt Status Register)**

(Address: 0Fh)

Bit 7	Bit 6	Bit 5	Bit 4	Bit 3	Bit 2	Bit 1	Bit 0
ICIF	LPWTF	HPWTF	CNT2F	CNT1F	INT1F	INT0F	TCIF
F	F	F	F	F	F	F	F

These bits are set to "1" when interrupt occurs.

**Bit 7 (ICIF):** Port 6, Port 8, input status changed interrupt flag. Set when Port 6, Port 8 input changes.

**Bit 6 (LPWTF):** Interrupt Flag of the internal Low-Pulse Width Timer underflow.

**Bit 5 (HPWTF):** Interrupt Flag of the internal High-Pulse Width Timer underflow.

**Bit 4 (CNT2F):** Interrupt Flag of the internal Counter 2 underflow.

**Bit 3 (CNT1F):** Interrupt Flag of the internal Counter 1 underflow.

**Bit 2 (INT1F):** External INT1 pin Interrupt Flag

**Bit 1 (INT0F):** External INT0 pin Interrupt Flag

**Bit 0 (TCIF):** TCC timer overflow Interrupt Flag. Set when TCC timer overflows.

### **6.1.17 Address: 10h~3Fh; R10~R3F (General Purpose Register)**

R10~R31F and R20~R3F (Banks 0~3) are general purpose registers.

## 6.2 Special Purpose Registers

### 6.2.1 A (Accumulator)

Internal data transfer operation, or instruction operand holding usually involves the temporary storage function of the Accumulator, which is not an addressable register.

#### ■ Registers of IOC Page 0 (IOC50 ~ IOCF0, Bit 0 of R5 = "0")

### 6.2.2 IOC50, P5CR (Port 5 I/O and Ports 7, 8 for LCD Segment Control Register)

(Address: 05h, Bit 0 of R5 = "0")

Bit 7	Bit 6	Bit 5	Bit 4	Bit 3	Bit 2	Bit 1	Bit 0
IOC57	IOC56	IOC55	IOC54	P8HS	P8LS	P7HS	P7LS
R/W	R/W	R/W	R/W	R/W	R/W	R/W	R/W

**Bits 7~4 (IOC57~54):** Port 5 I/O direction control register

**IOC5x = "0":** set the relative P5x I/O pins as output

**IOC5x = "1":** set the relative P5x I/O pin into high impedance (input pin)

**Bit 3 (P8HS):** Switch to high nibble I/O of Port 8 or to LCD segment output while sharing pins with SEGxx/P8x pins.

**P8HS = "0":** select high nibble of Port 8 as normal P84~P87

**P8HS = "1":** select LCD segment output as SEG 28~SEG 31 output

**Bit 2 (P8LS):** Switch to low nibble I/O of Port 8 or to LCD segment output while sharing pins with SEGxx/P8x pins

**P8LS = "0":** select low nibble of Port 8 as normal P80~P83

**P8LS = "1":** select LCD Segment output as SEG 24~SEG 27 output

**Bit 1 (P7HS):** Switch to high nibble I/O of Port 7 or to LCD segment output while sharing pins with SEGxx/P7x pins

**P7HS = "0":** select high nibble of Port 7 as normal P74~P77

**P7HS = "1":** select LCD Segment output as SEG 20~SEG 23 output

**Bit 0 (P7LS):** Switch to low nibble I/O of Port 7 or to LCD segment output while sharing pins with SEGxx/P7x pins

**P7LS = "0":** select low nibble of Port 7 as normal P70~P73

**P7LS = "1":** select LCD segment output as SEG 16~SEG 19 output

### 6.2.3 IOC60, P6CR (Port 6 I/O Control Register)

(Address: 06h, Bit 0 of R5 = "0")

Bit 7	Bit 6	Bit 5	Bit 4	Bit 3	Bit 2	Bit 1	Bit 0
IOC67	IOC66	IOC65	IOC64	IOC63	IOC62	IOC61	IOC60
R/W	R/W	R/W	R/W	R/W	R/W	R/W	R/W

**Bit 7 (IOC67) ~ Bit 0 (IOC60):** Port 6 I/O direction control register

**IOC6x = "0":** set the relative Port 6x I/O pins as output

**IOC6x = "1":** set the relative Port 6x I/O pin into high impedance (input pin)

### 6.2.4 IOC70, P7CR (Port 7 I/O Control Register)

(Address: 07h, Bit 0 of R5 = "0")

Bit 7	Bit 6	Bit 5	Bit 4	Bit 3	Bit 2	Bit 1	Bit 0
IOC77	IOC76	IOC75	IOC74	IOC73	IOC72	IOC71	IOC70
R/W	R/W	R/W	R/W	R/W	R/W	R/W	R/W

**Bit 7 (IOC77) ~ Bit 0 (IOC70):** Port 7 I/O direction control register

**IOC7x = "0":** set the relative Port 7x I/O pins as output

**IOC7x = "1":** set the relative Port 7x I/O pin into high impedance (input pin)

### 6.2.5 IOC80, P8CR (Port 8 I/O Control Register)

(Address: 08h, Bit 0 of R5 = "0")

Bit 7	Bit 6	Bit 5	Bit 4	Bit 3	Bit 2	Bit 1	Bit 0
IOC87	IOC86	IOC85	IOC84	IOC83	IOC82	IOC81	IOC80
R/W	R/W	R/W	R/W	R/W	R/W	R/W	R/W

**Bit 7 (IOC 87) ~ Bit 0 (IOC 80):** Port 8 I/O direction control register

**IOC8x = "0":** set the relative Port 8x I/O pins as output

**IOC8x = "1":** set the relative Port 8x I/O pin into high impedance (input pin)

### 6.2.6 IOC90, RAM\_ADDR (128 Bytes RAM Address)

(Address: 09h, Bit 0 of R5 = "0")

Bit 7	Bit 6	Bit 5	Bit 4	Bit 3	Bit 2	Bit 1	Bit 0
0	RAM_A6	RAM_A5	RAM_A4	RAM_A3	RAM_A2	RAM_A1	RAM_A0
0	R/W	R/W	R/W	R/W	R/W	R/W	R/W

**Bit 7:** Not used, fixed at "0"

**Bits 6~0:** 128 bytes RAM address

### 6.2.7 IOCA0, RAM\_DB (128 Bytes RAM Data Buffer)

(Address: 0Ah, Bit 0 of R5 = "0")

Bit 7	Bit 6	Bit 5	Bit 4	Bit 3	Bit 2	Bit 1	Bit 0
RAM_D7	RAM_D6	RAM_D5	RAM_D4	RAM_D3	RAM_D2	RAM_D1	RAM_D0
R/W	R/W	R/W	R/W	R/W	R/W	R/W	R/W

**Bits 7~0:** 128 bytes RAM data transfer register

### 6.2.8 IOCB0, CNT1PR (Counter 1 Preset Register)

(Address: 0Bh, Bit 0 of R5 = "0")

Bit 7	Bit 6	Bit 5	Bit 4	Bit 3	Bit 2	Bit 1	Bit 0
Bit 7	Bit 6	Bit 5	Bit 4	Bit 3	Bit 2	Bit 1	Bit 0
R/W	R/W	R/W	R/W	R/W	R/W	R/W	R/W

**Bit 7 ~ Bit 0:** These are Counter 1 buffers which user can read and write. Counter 1 is an 8-bit down-count timer with 8-bit prescaler used to preset the counter and read the preset value. The prescaler is set by the IOC91 register. After an interrupt, it will auto reload the preset value.

### 6.2.9 IOCC0, CNT2PR (Counter 2 Preset Register)

(Address: 0Ch, Bit 0 of R5 = "0")

Bit 7	Bit 6	Bit 5	Bit 4	Bit 3	Bit 2	Bit 1	Bit 0
Bit 7	Bit 6	Bit 5	Bit 4	Bit 3	Bit 2	Bit 1	Bit 0
R/W	R/W	R/W	R/W	R/W	R/W	R/W	R/W

**Bit 7 ~ Bit 0:** These are Counter 2 buffers which user can read and write. Counter 2 is an 8-bit down-count timer with 8-bit prescaler used to preset the counter and read the preset value. The prescaler is set by IOC91 register. After an interrupt, it will reload the preset value.

When IR output is enabled, this control register can obtain carrier frequency output.

If the Counter 2 clock source is equal to  $F_T$ ,

then

$$\text{Carrier frequency (F}_{\text{carrier}}) = \frac{F_T}{2 * (\text{preset\_value} + 1) * \text{prescaler}}$$

### 6.2.10 IOCD0, HPWTPR (High-Pulse Width Timer Preset Register)

(Address: 0Dh, Bit 0 of R5 = "0")

Bit 7	Bit 6	Bit 5	Bit 4	Bit 3	Bit 2	Bit 1	Bit 0
Bit 7	Bit 6	Bit 5	Bit 4	Bit 3	Bit 2	Bit 1	Bit 0
R/W	R/W	R/W	R/W	R/W	R/W	R/W	R/W

**Bit 7 ~ Bit 0:** These are high-pulse width timer buffers which user can read and write. High-pulse width timer preset register is an eight-bit down-counter with 8-bit prescaler used as IOCD0 to preset the counter and read the preset value. The prescaler is set by the IOCA1 register. After an interrupt, it will reload the preset value.

For PWM or IR application, this control register is set as high pulse width.

If the high-pulse width timer clock source is  $F_T$ , then

$$\text{High pulse time} = \frac{\text{prescaler} * (\text{preset\_value} + 1)}{F_T}$$

### 6.2.11 IOCE0, LPWTPR (Low-Pulse Width Timer Preset Register)

(Address: 0Eh, Bit 0 of R5 = "0")

Bit 7	Bit 6	Bit 5	Bit 4	Bit 3	Bit 2	Bit 1	Bit 0
Bit 7	Bit 6	Bit 5	Bit 4	Bit 3	Bit 2	Bit 1	Bit 0
R/W	R/W	R/W	R/W	R/W	R/W	R/W	R/W

**Bit 7 ~ Bit 0:** All are low-pulse width timer buffer that user can read and write. Low-pulse width timer preset is an eight-bit down-counter with 8-bit prescaler that is used as IOCE0 to preset the counter and read preset value. The prescaler is set by IOCA1 register. After an interrupt, it will reload the preset value.

For PWM or IR application, this control register is set as low pulse width.

If the low-pulse width timer clock source is  $F_T$ , then,

$$\text{Low pulse time} = \frac{\text{prescaler} * (\text{preset\_value} + 1)}{F_T}$$

### 6.2.12 IOCF0, IMR (Interrupt Mask Register)

(Address: 0Fh, Bit 0 of R5 = "0")

Bit 7	Bit 6	Bit 5	Bit 4	Bit 3	Bit 2	Bit 1	Bit 0
ICIE	LPWTE	HPWTE	CNT2E	CNT1E	INT1E	INT0E	TCIE
R/W	R/W	R/W	R/W	R/W	R/W	R/W	R/W

**Bit 7 ~ Bit 0:** interrupt enable bit. Enable the respective interrupt source.

**0:** disable interrupt

**1:** enable interrupt

The IOCF0 register is readable and writable.

■ Registers of IOC Page 1 (IOC61 ~ IOCE1, Bit 0 of R5 = "1")

**6.2.13 IOC61, WUCR (Wake-up and Sink Current of P57/IROUT Control Register)**

(Address: 06h, Bit 0 of R5 = "1")

Bit 7	Bit 6	Bit 5	Bit 4	Bit 3	Bit 2	Bit 1	Bit 0
IROCS	-	-	-	/WUE8H	/WUE8L	/WUE6H	/WUE6L
R/W	-	-	-	R/W	R/W	R/W	R/W

**Bit 7: IROCS:** IROUT/Port 57 output sink current set

IROCS	P57/IROUT Sink Current	
	VDD=5V	VDD=3V
0	10 mA	6 mA
1	20 mA	12 mA

**Bits 6, 5, 4:** Not used

**Bit 3 (/WUE8H):** 0/1 → enable/disable P84~P87 pin change wake-up function

**Bit 2 (/WUE8L):** 0/1 → enable/disable P80~P83 pin change wake-up function

**Bit 1 (/WUE6H):** 0/1 → enable/disable P64~P67 pin change wake-up function

**Bit 0 (/WUE6L):** 0/1 → enable/disable P60~P63 pin change wake-up function

\* Port 6 and Port 8 must not be set as input floating when wake-up function is enabled. "Enable" is the initial state of wake-up function.

**6.2.14 IOC71, TCCCR (TCC Control Register)**

(Address: 07h, Bit 0 of R5 = "1")

Bit 7	Bit 6	Bit 5	Bit 4	Bit 3	Bit 2	Bit 1	Bit 0
INT_EDGE	INT	TS	TE	PSRE	TCCP2	TCCP1	TCCP0
R/W	F	R/W	R/W	R/W	R/W	R/W	R/W

**Bit 7 (INT\_EDGE):**

**INT\_EDGE = "0":** Interrupt on the rising edge of P54/INT0 pin

**INT\_EDGE = "1":** Interrupt on the falling edge of P54/INT0 pin

**Bit 6 (INT):** INT enable flag, this bit is read only

**INT = "0":** interrupt masked by DISI or hardware interrupt

**INT = "1":** interrupt enabled by ENI/RETI instructions

**Bit 5 (TS):** TCC signal source

**TS = "0":** internal instruction cycle clock

**TS = "1":** transition on TCC pin, TCC period > internal instruction clock period

**Bit 4 (TE):** TCC signal edge

**TE = "0":** incremented by TCC pin rising edge

**TE = "1":** incremented by TCC pin falling edge

**Bits 3~0 (PSRE, TCCP2 ~ TCCP0):** TCC prescaler bits

PSRE	TCCP2	TCCP1	TCCP0	TCC Rate
0	×	×	×	1:1
1	0	0	0	1:2
1	0	0	1	1:4
1	0	1	0	1:8
1	0	1	1	1:16
1	1	0	0	1:32
1	1	0	1	1:64
1	1	1	0	1:128
1	1	1	1	1:256

### 6.2.15 IOC81, WDTCR (WDT Control Register)

(Address: 08h, Bit 0 of R5 = "1")

Bit 7	Bit 6	Bit 5	Bit 4	Bit 3	Bit 2	Bit 1	Bit 0
–	–	–	–	WDTE	WDTP2	WDTP1	WDTP0
–	–	–	–	R/W	R/W	R/W	R/W

**Bits 7 ~ 4:** Not used

**Bit 3 (WDTE):** Watchdog timer enable. This control bit is used to enable the Watchdog timer,

**WDTE = "0":** Disable WDT function

**WDTE = "1":** Enable WDT function

**Bits 2 ~ 0 (WDTP2 ~ WDTP0):** Watchdog Timer prescaler bits. The WDT clock source is sub-oscillation frequency.

WDTP2	WDTP1	WDTP0	WDT Rate
0	0	0	1:1
0	0	1	1:2
0	1	0	1:4
0	1	1	1:8
1	0	0	1:16
1	0	1	1:32
1	1	0	1:64
1	1	1	1:128

### 6.2.16 IOC91, CNT12CR (Counters 1, 2 Control Register)

(Address: 09h, Bit 0 of R5 = "1")

Bit 7	Bit 6	Bit 5	Bit 4	Bit 3	Bit 2	Bit 1	Bit 0
CNT2S	CNT2P2	CNT2P1	CNT2P0	CNT1S	CNT1P2	CNT1P1	CNT1P0
R/W	R/W	R/W	R/W	R/W	R/W	R/W	R/W

**Bit 7 (CNT2S):** Counter 2 clock source select

"0": Fs (Fs: sub-oscillator clock)

"1": Fm (Fm: main-oscillator clock)

**Bits 6~4 (CNT2P2 ~ CNT2P0):** Counter 2 prescaler select bits

CNT2P2	CNT2P1	CNT1P0	Counter 2 Scale
0	0	0	1:2
0	0	1	1:4
0	1	0	1:8
0	1	1	1:16
1	0	0	1:32
1	0	1	1:64
1	1	0	1:128
1	1	1	1:256

**Bit 3 (CNT1S):** Counter 1 Clock Source Select

"0": Fs (Fs: sub-oscillator clock)

"1": Fm (Fm: main-oscillator clock)

**Bits 2~0 (CNT1P2 ~ CNT1P0):** Counter 1 prescaler select bits

CNT1P2	CNT1P1	CNT1P0	Counter 1 Scale
0	0	0	1:2
0	0	1	1:4
0	1	0	1:8
0	1	1	1:16
1	0	0	1:32
1	0	1	1:64
1	1	0	1:128
1	1	1	1:256

### 6.2.17 IOCA1, HLPWTCR (High/Low Pulse Width Timer Control Register)

(Address: 0Ah, Bit 0 of R5 = "1")

Bit 7	Bit 6	Bit 5	Bit 4	Bit 3	Bit 2	Bit 1	Bit 0
LPWTS	LPWTP2	LPWTP1	LPWTP0	HPWTS	HPWTP2	HPWTP1	HPWTP0
R/W	R/W	R/W	R/W	R/W	R/W	R/W	R/W

**Bit 7 (LPWTS):** Low-Pulse Width Timer Clock Source Select

"0": Fs (Fs: sub-oscillator clock)

"1": Fm (Fm: main-oscillator clock)

**Bits 6~4 (LPWTP2~ LPWTP0):** Low-Pulse Width Timer Prescaler Select bits

LPWTP2	LPWTP1	LPWTP0	Low-pulse Width Timer Scale
0	0	0	1:2
0	0	1	1:4
0	1	0	1:8
0	1	1	1:16
1	0	0	1:32
1	0	1	1:64
1	1	0	1:128
1	1	1	1:256

**Bit 3 (HPWTS):** High-Pulse Width Timer Clock Source Select

"0": Fs (Fs: sub-oscillator clock)

"1": Fm (Fm: main-oscillator clock)

**Bits 2~0 (HPWTP2~ HPWTP0): High-Pulse Width Timer Prescaler Select bits**

HPWTP2	HPWTP1	HPWTP0	High-pulse Width Timer Scale
0	0	0	1:2
0	0	1	1:4
0	1	0	1:8
0	1	1	1:16
1	0	0	1:32
1	0	1	1:64
1	1	0	1:128
1	1	1	1:256

### 6.2.18 IOCB1, P6PH (Port 6 Pull-high Control Register)

Address: 0Bh, Bit 0 of R5 = "1"

Bit 7	Bit 6	Bit 5	Bit 4	Bit 3	Bit 2	Bit 1	Bit 0
PH67	PH66	PH65	PH64	PH63	PH62	PH61	PH60
R/W	R/W	R/W	R/W	R/W	R/W	R/W	R/W

**Bit 7 ~ Bit 0 (PH67 ~ PH60):** These are the enable bits of Port 6 pull high function.

**PH6x = "0":** disable P6x pin internal pull-high resistor function

**PH6x = "1":** enable P6x pin internal pull-high resistor function

### 6.2.19 IOCC1, P6OD (Port 6 Open Drain Control Register)

(Address: 0Ch, Bit 0 of R5 = "1")

Bit 7	Bit 6	Bit 5	Bit 4	Bit 3	Bit 2	Bit 1	Bit 0
OP67	OP66	OP65	OP64	OP63	OP62	OP61	OP60
R/W	R/W	R/W	R/W	R/W	R/W	R/W	R/W

**Bit 7 ~ Bit 0:** These are the enable bits of Port 6 open drain function.

**OD6x = "0":** disable pin P6x open drain function

**OD6x = "1":** enable pin P6x open drain function

### 6.2.20 IOCD1, P8PH (Port 8 Pull High Control Register)

(Address: 0Dh, Bit 0 of R5 = "1")

Bit 7	Bit 6	Bit 5	Bit 4	Bit 3	Bit 2	Bit 1	Bit 0
PH87	PH86	PH85	PH84	PH83	PH82	PH81	PH80
R/W	R/W	R/W	R/W	R/W	R/W	R/W	R/W

**Bit 7 ~ Bit 0:** These are the enable bits of Port 8 pull-high function.

**PH8x = "0":** disable P8x pin internal pull-high resistor function

**PH8x = "1":** enable P8x pin internal pull-high resistor function

### 6.2.21 IOCE1, P6PL (Port 6 Pull Low Control Register)

(Address: 0Eh, Bit 0 of R5 = "1")

Bit 7	Bit 6	Bit 5	Bit 4	Bit 3	Bit 2	Bit 1	Bit 0
PL67	PL66	PL65	PL64	PL63	PL62	PL61	PL60
R/W	R/W	R/W	R/W	R/W	R/W	R/W	R/W

**Bit 7 ~ Bit 0:** These are the enable bits of Port 6 pull low function.

**PL6x = "0":** disable P6x pin internal pull-low resistor function

**PL6x = "1":** enable P6x pin internal pull-low resistor function

## 6.3 TCC and WDT Prescaler

Two 8-bit counters are available as prescalers for the TCC (Time Clock Counter) and WDT (Watchdog Timer). The TCCP2~TCCP0 bits of the IOC71 register are used to determine the ratio of the TCC prescaler. Likewise, the WDTP2~WDTP0 bits of the IOC81 register are used to determine the WDT prescaler. The TCC prescaler (TCCP2~TCCP0) is cleared by the instructions each time they are written into TCC, while the WDT prescaler is cleared by the "WDTC" and "SLEP" instructions. Fig.7 depicts the circuit diagram of TCC and WDT.

R1 (TCC) is an 8-bit timer/counter. The clock source of TCC can be selected by internal instruction clock or external signal input (edge selectable from the TCC control register). If the TCC signal source is from the internal instruction clock, the TCC will be incremented by 1 at every instruction cycle (without prescaler). If the TCC signal source is from an external clock input, the TCC will be incremented by 1 at every falling edge or rising edge of the TCC pin.

The Watchdog Timer is free running on sub-oscillator. The WDT will keep on running even after the oscillator driver has been turned off. During Normal mode, Green mode, or Idle mode operation, a WDT time-out (if enabled) will cause the device to reset. The WDT can be enabled or disabled at any time during the Normal mode and Green mode by software programming. Refer to WDTE bit of IOC81 register. The WDT time-out period is equal to (prescaler × 256 / (Fs/2)).

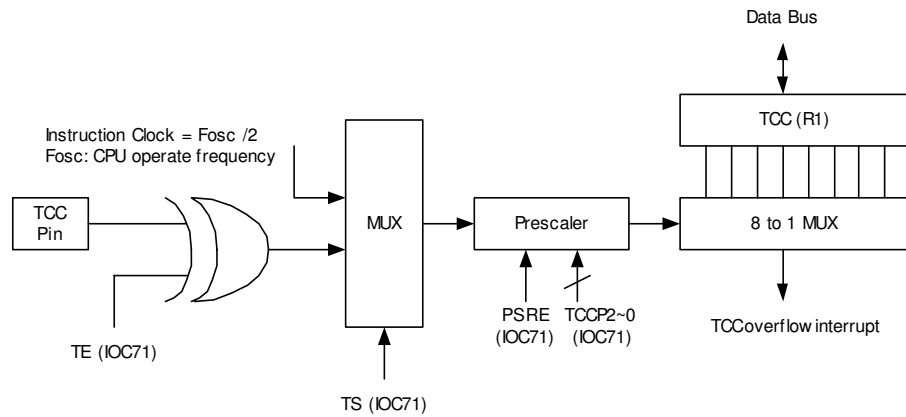

Figure 6-4(a) Block Diagram of TCC

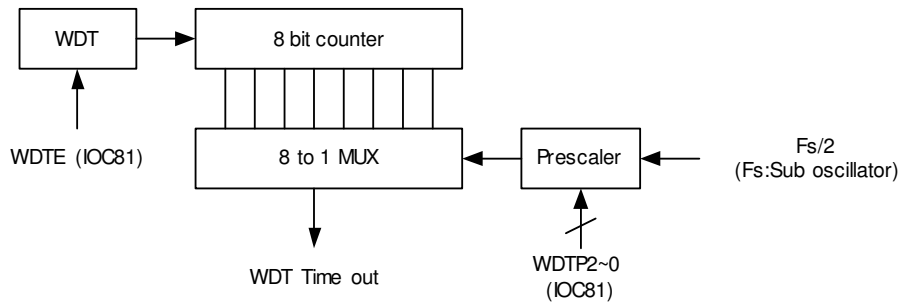
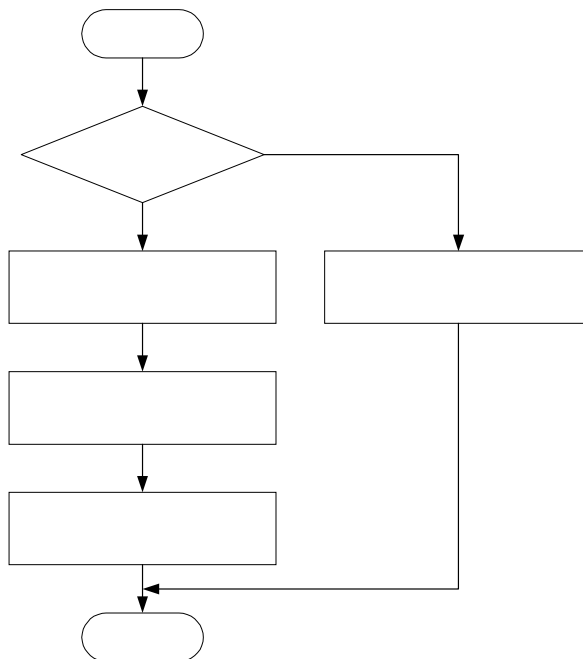
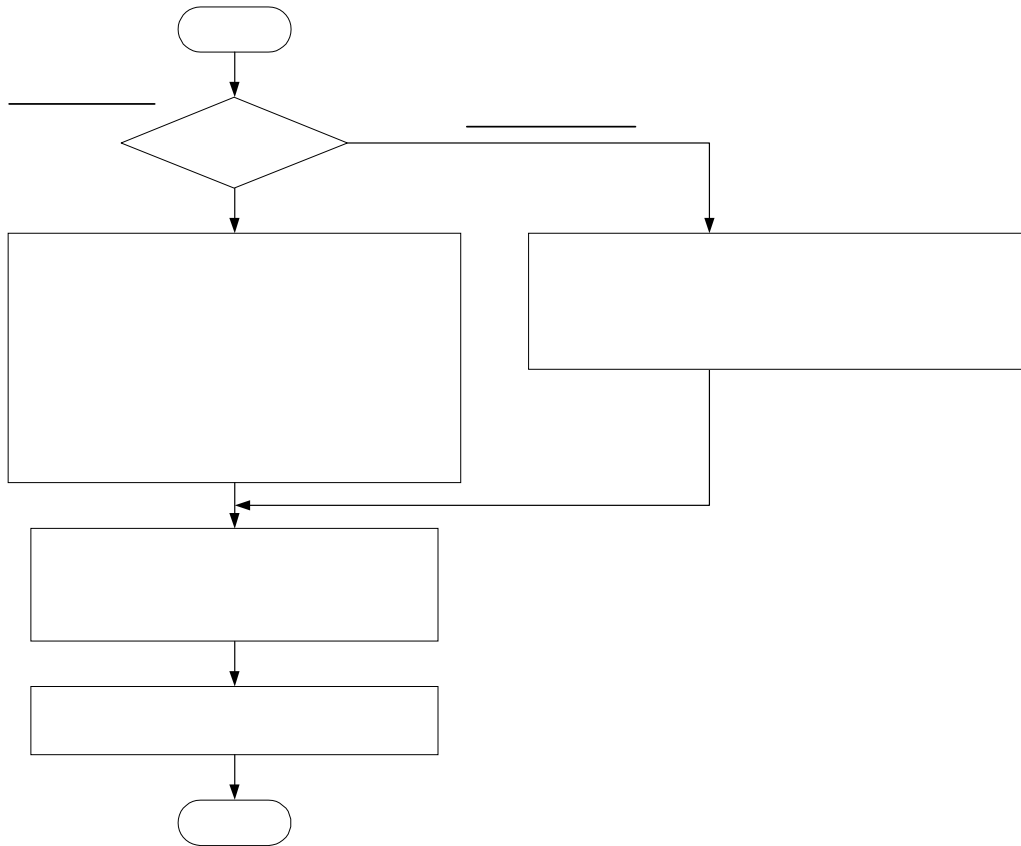

Figure 6-4(b) Block Diagram of WDT

**WDT Setting Flowchart**



**TCC Setting Flowchart**



## 6.4 I/O Ports

The I/O registers, (Port 5, Port 6, Port 7 and Port 8), are bi-directional tri-state I/O ports. Port 6 and Port 8 are pulled-high internally by software; Port 6 is also pulled-low internally by software. Furthermore, Port 6 has its open-drain output also through software. Port 6 and Port 8 features an input status changed interrupt (or wake-up) function and is pulled-high by software. Each I/O pin can be defined as "input" or "output" pin by the I/O control register (IOC50 ~ IOC80). The I/O registers and I/O control registers are both readable and writable. The I/O interface circuits are shown in Figure 6-5.

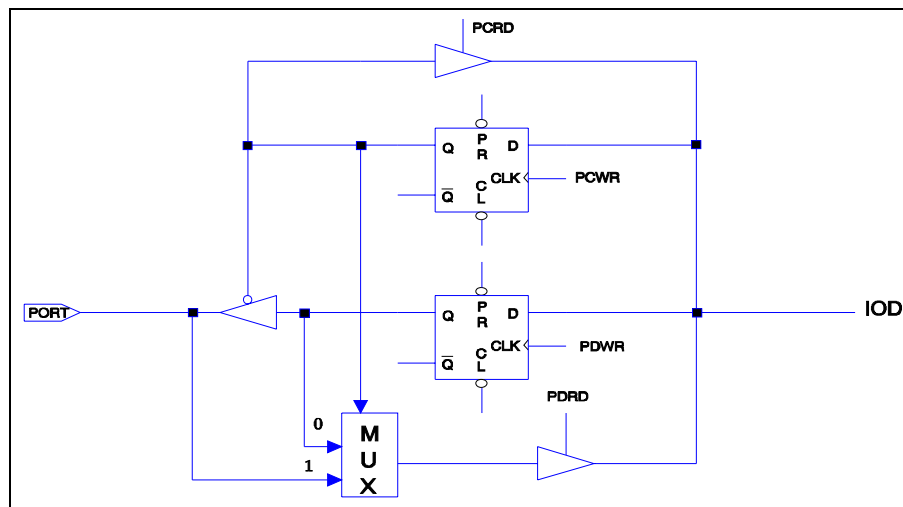

**Note:** Open-drain, pull-high, and pull down are not shown in the figure.

Figure 6-5 Circuit of I/O Port and I/O Control Register for Port 5 ~ 8

## 6.5 Reset and Wake-up

A reset can be activated by

- POR (Power-on Reset)
- WDT timeout (if enabled)
- /RESET pin goes to low

**Note:** The reset circuit is always enabled. It will reset the CPU at 1.9V.

Once a reset occurs, the following functions are performed

- The oscillator is running, or will be started
- The program counter (R2/PC) is set to all "0"
- All I/O port pins are configured as input mode (high-impedance state)
- The TCC/Watchdog timer and prescaler are cleared
- When power is on, the Bits 5 and 6 of R3 and the upper two bits of R4 are cleared.
- Bits of the IOC71 register are set to all "1" except for Bit 6 (INT flag)
- For other registers, see Table 2



**Table 2 Summary of Registers Initialized Values**

Address	Name	Reset Type	Bit 7	Bit 6	Bit 5	Bit 4	Bit 3	Bit 2	Bit 1	Bit 0
0x05	IOC50 (P5CR)	Bit Name	IOC57	IOC56	IOC55	IOC54	P8HS	P8LS	P7HS	P7LS
		Power-on	1	1	1	1	0	0	0	0
		/RESET & WDT	1	1	1	1	0	0	0	0
		Wake-up from Pin Change	P	P	P	P	P	P	P	P
0x06	IOC60 (P6CR)	Bit Name	IOC67	IOC66	IOC65	IOC64	IOC63	IOC62	IOC61	IOC60
		Power-on	1	1	1	1	1	1	1	1
		/RESET & WDT	1	1	1	1	1	1	1	1
		Wake-up from Pin Change	P	P	P	P	P	P	P	P
0x07	IOC70 (P7CR)	Bit Name	IOC77	IOC76	IOC75	IOC74	IOC73	IOC72	IOC71	IOC70
		Power-on	1	1	1	1	1	1	1	1
		/RESET & WDT	1	1	1	1	1	1	1	1
		Wake-up from Pin Change	P	P	P	P	P	P	P	P
0x08	IOC80 (P8CR)	Bit Name	IOC87	IOC86	IOC85	IOC84	IOC83	IOC82	IOC81	IOC80
		Power-on	1	1	1	1	1	1	1	1
		/RESET & WDT	1	1	1	1	1	1	1	1
		Wake-up from Pin Change	P	P	P	P	P	P	P	P
0x09	IOC90 (RAM_ADDR)	Bit Name	X	RAM_A6	RAM_A5	RAM_A4	RAM_A3	RAM_A2	RAM_A1	RAM_A0
		Power-on	0	0	0	0	0	0	0	0
		/RESET & WDT	0	0	0	0	0	0	0	0
		Wake-up from Pin Change	P	P	P	P	P	P	P	P
0x0A	IOCA0 (RAM_DB)	Bit Name	RAM_D7	RAM_D6	RAM_D5	RAM_D4	RAM_D3	RAM_D2	RAM_D1	RAM_D0
		Power-on	U	U	U	U	U	U	U	U
		/RESET & WDT	P	P	P	P	P	P	P	P
		Wake-Up from Pin Change	P	P	P	P	P	P	P	P
0x0B	IOCB0 (CNT1PR)	Bit Name	Bit 7	Bit 6	Bit 5	Bit 4	Bit 3	Bit 2	Bit 1	Bit 0
		Power-on	0	0	0	0	0	0	0	0
		/RESET & WDT	0	0	0	0	0	0	0	0
		Wake-up from Pin Change	P	P	P	P	P	P	P	P
0x0C	IOCC0 (CNT2PR)	Bit Name	Bit 7	Bit 6	Bit 5	Bit 4	Bit 3	Bit 2	Bit 1	Bit 0
		Power-on	0	0	0	0	0	0	0	0
		/RESET & WDT	0	0	0	0	0	0	0	0
		Wake-up from Pin Change	P	P	P	P	P	P	P	P
0x0D	IOCD0 (HPWTPR)	Bit Name	Bit 7	Bit 6	Bit 5	Bit 4	Bit 3	Bit 2	Bit 1	Bit 0
		Power-on	0	0	0	0	0	0	0	0
		/RESET & WDT	0	0	0	0	0	0	0	0
		Wake-up from Pin Change	P	P	P	P	P	P	P	P
0x0E	IOCE0 (LPWTPR)	Bit Name	Bit 7	Bit 6	Bit 5	Bit 4	Bit 3	Bit 2	Bit 1	Bit 0
		Power-on	0	0	0	0	0	0	0	0
		/RESET & WDT	0	0	0	0	0	0	0	0
		Wake-up from Pin Change	P	P	P	P	P	P	P	P
0x0F	IOCF0 (IMR)	Bit Name	ICIE	LPWTE	HPWTE	CNT2E	CNT1E	INT1E	INT0E	TCIE
		Power-on	0	0	0	0	0	0	0	0
		/RESET & WDT	0	0	0	0	0	0	0	0
		Wake-up from Pin Change	P	P	P	P	P	P	P	P
0x06	IOC61 (WUCR)	Bit Name	IROCS	X	X	X	/WUE8H	/WUE8L	/WUE6H	/WUE6L
		Power-on	0	U	U	U	0	0	0	0
		/RESET & WDT	0	U	U	U	0	0	0	0
		Wake-up from Pin Change	P	U	U	U	P	P	P	P



Address	Name	Reset Type	Bit 7	Bit 6	Bit 5	Bit 4	Bit 3	Bit 2	Bit 1	Bit 0
0x07	IOC71 (TCCCR)	Bit Name	INT_EDGE	INT	TS	TE	PSRE	TCCP2	TCCP1	TCCP0
		Power-on	1	0	1	1	1	1	1	1
		/RESET & WDT	1	0	1	1	1	1	1	1
		Wake-up from Pin Change	P	P	P	P	P	P	P	P
0x08	IOC81 (WDTCR)	Bit Name	X	X	X	X	WDTE	WDTP2	WDTP1	WDTP0
		Power-on	U	U	U	U	0	1	1	1
		/RESET & WDT	U	U	U	U	0	1	1	1
		Wake-up from Pin Change	U	U	U	U	P	P	P	P
0x09	IOC91 (CNT12CR)	Bit Name	CNT2S	CNT2P2	CNT2P1	CNT2P0	CNT1S	CNT1P2	CNT1P1	CNT1P0
		Power-on	0	0	0	0	0	0	0	0
		/RESET & WDT	0	0	0	0	0	0	0	0
		Wake-up from Pin Change	P	P	P	P	P	P	P	P
0x0A	IOCA1 (HLPWTCR)	Bit Name	LPWTS	LPWTP2	LPWTP1	LPWTP0	HPWTS	HPWTP2	HPWTP1	HPWTP0
		Power-on	0	0	0	0	0	0	0	0
		/RESET & WDT	0	0	0	0	0	0	0	0
		Wake-up from Pin Change	P	P	P	P	P	P	P	P
0x0B	IOCB1 (P6PH)	Bit Name	PH67	PH66	PH65	PH64	PH63	PH62	PH61	PH60
		Power-on	0	0	0	0	0	0	0	0
		/RESET & WDT	0	0	0	0	0	0	0	0
		Wake-up from Pin Change	P	P	P	P	P	P	P	P
0x0C	IOCC1 (P6OD)	Bit Name	OP67	OP66	OP65	OP64	OP63	OP62	OP61	OP60
		Power-on	0	0	0	0	0	0	0	0
		/RESET & WDT	0	0	0	0	0	0	0	0
		Wake-up from Pin Change	P	P	P	P	P	P	P	P
0x0D	IOCD1 (P8PH)	Bit Name	PH87	PH86	PH85	PH84	PH83	PH82	PH81	PH80
		Power-on	0	0	0	0	0	0	0	0
		/RESET & WDT	0	0	0	0	0	0	0	0
		Wake-up from Pin Change	P	P	P	P	P	P	P	P
0x0E	IOCE1 (P6PL)	Bit Name	PL67	PL66	PL65	PL64	PL63	PL62	PL61	PL60
		Power-on	0	0	0	0	0	0	0	0
		/RESET & WDT	0	0	0	0	0	0	0	0
		Wake-up from Pin Change	P	P	P	P	P	P	P	P
0x00	R0 (IAR)	Bit Name	Bit 7	Bit 6	Bit 5	Bit 4	Bit 3	Bit 2	Bit 1	Bit 0
		Power-on	U	U	U	U	U	U	U	U
		/RESET & WDT	P	P	P	P	P	P	P	P
		Wake-up from Pin Change	P	P	P	P	P	P	P	P
0x01	R1 (TCC)	Bit Name	Bit 7	Bit 6	Bit 5	Bit 4	Bit 3	Bit 2	Bit 1	Bit 0
		Power-on	0	0	0	0	0	0	0	0
		/RESET & WDT	0	0	0	0	0	0	0	0
		Wake-up from Pin Change	P	P	P	P	P	P	P	P
0x02	R2 (PC)	Bit Name	Bit 7	Bit 6	Bit 5	Bit 4	Bit 3	Bit 2	Bit 1	Bit 0
		Power-on	0	0	0	0	0	0	0	0
		/RESET & WDT	0	0	0	0	0	0	0	0
		Wake-up from Pin Change	Jump to Address 0x0018 or continue to execute next instruction.							
0x03	R3 (SR)	Bit Name	X	PS1	PS0	T	P	Z	DC	C
		Power-on	U	0	0	1	1	U	U	U
		/RESET & WDT	U	0	0	t	t	P	P	P
		Wake-up from Pin Change	U	P	P	t	t	P	P	P
0x04	R4 (RSR)	Bit Name	RBS1	RBS0	RSR5	RSR4	RSR3	RSR2	RSR1	RSR0
		Power-on	0	0	U	U	U	U	U	U
		/RESET & WDT	0	0	P	P	P	P	P	P
		Wake-up from Pin Change	P	P	P	P	P	P	P	P



Address	Name	Reset Type	Bit 7	Bit 6	Bit 5	Bit 4	Bit 3	Bit 2	Bit 1	Bit 0
0x05	R5 (Port 5)	Bit Name	R57	R56	R55	R54	X	X	X	IOCPAGE
		Power-on	1	1	1	1	U	U	U	0
		/RESET & WDT	1	1	1	1	U	U	U	0
		Wake-up from Pin Change	P	P	P	P	U	U	U	P
0x06	R6 (Port 6)	Bit Name	R67	R66	R65	R64	R63	R62	R61	R60
		Power-on	1	1	1	1	1	1	1	1
		/RESET & WDT	1	1	1	1	1	1	1	1
		Wake-up from Pin Change	P	P	P	P	P	P	P	P
0x07	R7 (Port 7)	Bit Name	R77	R76	R75	R74	R73	R62	R71	R70
		Power-on	1	1	1	1	1	1	1	1
		/RESET & WDT	1	1	1	1	1	1	1	1
		Wake-up from Pin Change	P	P	P	P	P	P	P	P
0x08	R8 (Port 8)	Bit Name	R87	R86	R85	R84	R83	R82	R81	R80
		Power-on	1	1	1	1	1	1	1	1
		/RESET & WDT	1	1	1	1	1	1	1	1
		Wake-up from Pin Change	P	P	P	P	P	P	P	P
0x09	R9 (LCDCR)	Bit Name	BS	DS1	DS0	LCDEN	X	LCDDTYPE	LCDF1	LCDF0
		Power-on	1	1	0	0	U	0	0	0
		/RESET & WDT	1	1	0	0	U	0	0	0
		Wake-up from Pin Change	P	P	P	P	U	P	P	P
0xA	RA (LCD_ADDR)	Bit Name	X	X	X	LCD_A4	LCD_A3	LCD_A2	LCD_A1	LCD_A0
		Power-on	0	0	0	0	0	0	0	0
		/RESET & WDT	0	0	0	0	0	0	0	0
		Wake-up from Pin Change	P	P	P	P	P	P	P	P
0xB	RB (LCD_DB)	Bit Name	X	X	X	X	LCD_D3	LCD_D2	LCD_D1	LCD_D0
		Power-on	U	U	U	U	U	U	U	U
		/RESET & WDT	U	U	U	U	P	P	P	P
		Wake-up from Pin Change	U	U	U	U	P	P	P	P
0xC	RC (CNTER)	Bit Name	X	X	X	X	LPWTEN	HPWTEN	CNT2EN	CNT1EN
		Power-on	0	1	0	0	0	0	0	0
		/RESET & WDT	0	1	0	0	0	0	0	0
		Wake-up from Pin Change	P	P	0	P	P	P	P	P
0xD	RD (SBPCR)	Bit Name	X	CLK2	CLK1	CLK0	IDLE	BF1	BF0	CPUS
		Power-on	U	0	0	0	1	0	0	*1
		/RESET & WDT	U	0	0	0	1	0	0	*1
		Wake-up from Pin Change	U	P	P	P	P	P	P	P
0xE	RE (IRCR)	Bit Name	IRE	HF	LGP	X	IROUTE	TCCE	EINT1	EINT0
		Power-on	0	0	0	U	0	0	0	0
		/RESET & WDT	0	0	0	U	0	0	0	0
		Wake-up from Pin Change	P	P	P	U	P	P	P	P
0xF	RF (ISR)	Bit Name	ICIF	LPWTF	HPWTF	CNT2F	CNT1F	INT1F	INT0F	TCIF
		Power-on	0	0	0	0	0	0	0	0
		/RESET & WDT	0	0	0	0	0	0	0	0
		Wake-up from Pin Change	N	P	P	P	P	P	P	P
0x10 ~ 0x3F	R10~R3F	Bit Name	Bit 7	Bit 6	Bit 5	Bit 4	Bit 3	Bit 2	Bit 1	Bit 0
		Power-on	U	U	U	U	U	U	U	U
		/RESET & WDT	P	P	P	P	P	P	P	P
		Wake-up from Pin Change	P	P	P	P	P	P	P	P

**Note:** This bit is equal to the Code Option HLFS bit data

**Legend:** "x" = not used "P" = previous value before reset  
 "-" = Not defined "t" = check R3 register explanation  
 "u" = unknown or don't care "N" = Monitors interrupt operation status

The controller can be awakened from sleep mode and idle mode. The wake-up signals are listed as follows:

Wake-up Signal	Sleep Mode	Idle Mode	Green Mode	Normal Mode
TCC time out IOCF0 Bit 0=1	×	×	Interrupt	Interrupt
INT0 pin IOCF0 Bit 1=1	Wake-up + interrupt + next instruction	Wake-up + interrupt + next instruction	Interrupt	Interrupt
INT1 pin IOCF0 Bit 2=1	Wake-up + interrupt + next instruction	Wake-up + interrupt + next instruction	Interrupt	Interrupt
Counter 1 IOCF0 Bit 3=1	×	Wake-up + interrupt + next instruction	Interrupt	Interrupt
Counter 2 IOCF0 Bit 4=1	×	Wake-up + interrupt + next instruction	Interrupt	Interrupt
High-pulse timer IOCF0 Bit 5=1	×	Wake-up + interrupt + next instruction	Interrupt	Interrupt
Low-pulse timer IOCF0 Bit 6=1	×	Wake-up + interrupt + next instruction	Interrupt	Interrupt
Port 6, Port 8 (input status change wake-up) Bit 7 of IOCF0 = "0"	Wake-up + next instruction	Wake-up + next instruction	×	×
Port 6, Port 8 (input status change wake-up) Bit 7 of IOCF0 = "1"	Wake-up + interrupt + next instruction	Wake-up + interrupt + next instruction	×	×
WDT time out	×	RESET	RESET	RESET

## 6.6 Oscillator

### 6.6.1 Oscillator Modes

The EM78P468B can operate in three different oscillator modes:

- Main oscillator (R-OSCI, OSCO), such as RC oscillator with external resistor and Internal capacitor mode (ERIC)
- Crystal oscillator mode
- PLL operation mode (R-OSCI connected to 0.01 $\mu$ F capacitor to Ground). User can select which mode by programming FMMD1 and FMMD0 in the Code Options Register. The sub-oscillator can be operated in Crystal mode and ERIC mode. Table 3 below shows how these three modes are defined.

Table 3 Oscillator Modes as defined by FSMD, FMMD1, FMMD0

FSMD	FMMD1	FMMD0	Main Clock	Sub-clock
0	0	0	RC type (ERIC)	RC type (ERIC)
0	0	1	Crystal type	RC type (ERIC)
0	1	×	PLL type	RC type (ERIC)
1	0	0	RC type (ERIC)	Crystal type
1	0	1	Crystal type	Crystal type
1	1	×	PLL type	Crystal type

Table 4 Summary of Maximum Operating Speeds

Conditions	VDD	Fxt Max. (MHz)
Two clocks	2.3	4
	3.0	8
	5.0	10

### 6.6.2 Phase Lock Loop (PLL Mode)

When operate on PLL mode, the High frequency determined by sub-oscillator. We can choose RD register to change high oscillator frequency. The relation between high frequency (Fm) and sub-oscillator is shown as below table:

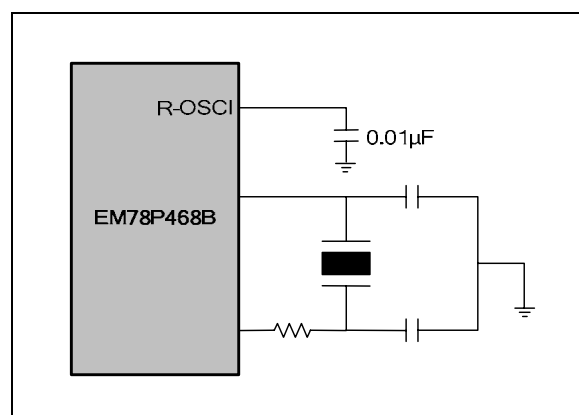

Figure 6-6 PLL Mode Circuit

Bits 6~4 (CLK2~0) of RD: Main clock selection bits for PLL mode (code option select)

CLK2	CLK1	CLK0	Main clock	Example Fs=32.768kHz
0	0	0	$F_s \times 130$	4.26 MHz
0	0	1	$F_s \times 65$	2.13 MHz
0	1	0	$F_s \times 65/2$	1.065 MHz
0	1	1	$F_s \times 65/4$	532kHz
1	×	×	$F_s \times 244$	8 MHz

### 6.6.3 Crystal Oscillator/Ceramic Resonators (Crystal)

This LSI can be driven by an external clock signal through the R-OSCI pin as shown in Fig. 6-7 below. In most applications, the R-OSCI pin and the OSCO pin can be connected with a crystal or ceramic resonator to generate oscillation. Fig. 6-8 depicts such circuit. Table 5 provides the recommended values of C1 and C2. Since each resonator has its own attribute, user should refer to its specification for appropriate values of C1 and C2. RS, a serial resistor, may be necessary for AT strip cut crystal or low frequency mode.

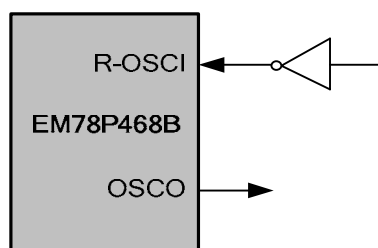

Figure 6-7 External Clock Input Circuit

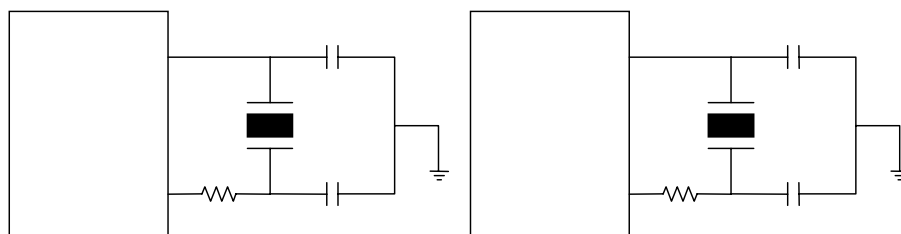

Figure 6-8 Circuit for Crystal/Resonator

Table 5 Capacitor Selection Guide for Crystal Oscillator or Ceramic Resonators

Oscillator Source	Oscillator Type	Frequency	C1 (pF)	C2 (pF)
Main oscillator	Ceramic Resonators	455kHz	100~150	100~150
		2.0 MHz	20~40	20~40
		4.0 MHz	10~30	10~30
	Crystal Oscillator	455kHz	20~40	20~150
		1.0 MHz	15~30	15~30
		2.0 MHz	15	15
Sub-oscillator	Crystal Oscillator	4.0 MHz	15	15
		32.768kHz	25	25

### 6.6.4 RC Oscillator Mode with Internal Capacitor

If both precision and cost are taken into consideration, this LSI also offers a special oscillation mode, which has an on-chip internal capacitor and an external resistor connected to VDD. The internal capacitor functions as temperature compensator. In order to obtain more accurate frequency, a precise resistor is recommended.

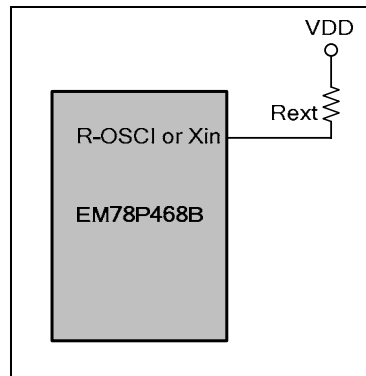

Figure 6-9 Circuit for Internal C Oscillator Mode

Table 6 RC Oscillator Frequencies

Pin	Rext	Average Fosc 5V, 25°C	Average Fosc 3V, 25°C
R-OSCI	51k	2.2221 MHz	2.1972 MHz
	100k	1.1345 MHz	1.1203 MHz
	300k	381.36kHz	374.77kHz
Xin	2.2M	32.768kHz	32.768kHz

**Note:** Measured from QFP packages with frequency drift of about  $\pm 30\%$ .

Values are provided for design reference only.

## 6.7 Power-on Considerations

Any microcontroller (as with this LSI) is not warranted to start operating properly before the power supply stabilizes in a steady state. This LSI has an on-chip Power-on Reset (POR) with detection level range as shown on the table below. The circuitry eliminates the extra external reset circuit but will work well only if the VDD rises quickly enough (50ms or less). However, under critical applications, extra devices are still required to assist in solving power-on problems.

Power-on voltage detector provided

IC	Voltage Range
EM78P468B	1.7V to 1.9V

### 6.7.1 External Power-on Reset Circuit

This circuit implements an external RC to produce a reset pulse (see Figure 6-10). The pulse width (time constant) should be kept long enough to allow VDD to reach minimum operation voltage. This circuit is used when the power supply rise time is slow. Because the current leakage from the /RESET pin is  $\pm 5 \mu\text{A}$ , it is recommended that R should not be greater than 40K. In this way, the voltage at Pin /RESET is held below 0.2V. The diode (D) acts as a short circuit at power-down. The capacitor, C, is discharged rapidly and fully. Rin, the current-limited resistor, prevents high current discharge or ESD (electrostatic discharge) from flowing into Pin /RESET.

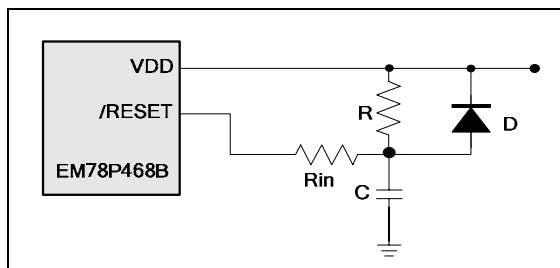

Figure 6-10 External Power-on Reset Circuit

### 6.7.2 Residue-Voltage Protection

When battery is replaced, device power (VDD) is disconnected but residue-voltage remains. The residue-voltage may trips below minimum VDD, but above zero. This condition may cause poor power on reset. Figure 6-11 and Figure 6-12 show how to build a residue-voltage protection circuit.

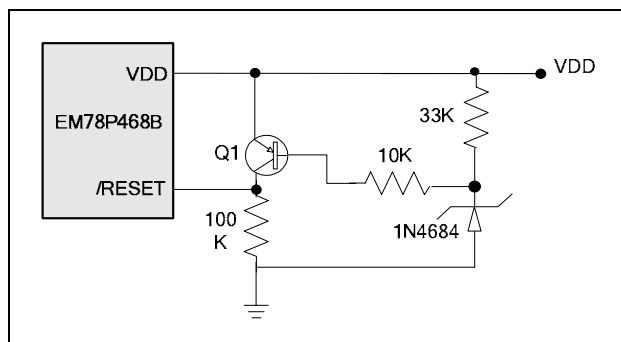

Figure 6-11 Residue Voltage Protection Circuit 1

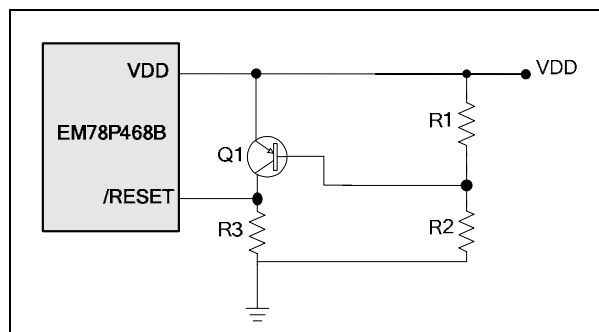

Figure 6-12 Residue Voltage Protection Circuit 2

## 6.8 Interrupt

This LSI has eight interrupt sources as listed below:

- TCC overflow interrupt
- External interrupt P54/INT0 pin
- External interrupt P55/INT1 pin
- Counter 1 underflow interrupt
- Counter 2 underflow interrupt
- High-pulse width timer underflow interrupt
- Low-pulse width timer underflow interrupt
- Port 6, Port 8 input status change wake-up

This IC has internal interrupts which are falling edge triggered or as follows:

- TCC timer overflow interrupt
- Four 8-bit down counter/timer underflow interrupt

If these interrupt sources change signal from high to low, the RF register will generate a “1” flag to the corresponding register if the IOCF0 register is enabled.

RF is the interrupt status register. It records the interrupt request in flag bit. IOCF0 is the interrupt mask register. Global interrupt is enabled by ENI instruction and disabled by DISI instruction. When one of the interrupts (when enabled) is generated, it will cause the next instruction to be fetch from Address 0003H~0018H according to interrupt source.

With this LSI, each individual interrupt source has its own interrupt vector as depicted in Table 3. Before the interrupt subroutine is executed, the contents of the ACC and the R3 register are initially saved by the hardware. After the interrupt service routine is completed, the ACC and R3 are restored. The existing interrupt service routine does not allow other interrupt service routine to be executed. Hence, if other interrupts occur while an existing interrupt service routine is being executed, the hardware will save the later interrupts. Only after the existing interrupt service routine is completed that the next interrupt service routine is executed.

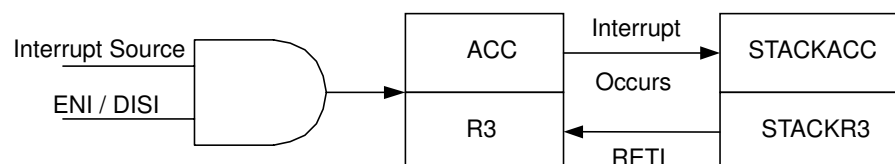

Fig. 6-13 Interrupt Back-up Diagram

Table 3 Interrupt Vector

Interrupt Vector	Interrupt Status
0003H	TCC overflow interrupt.
0006H	External interrupt P5.4/INT0 pin
0009H	External interrupt P5.5/INT1 pin
000CH	Counter 1 underflow interrupt
000FH	Counter 2 underflow interrupt
0012H	High-pulse width timer underflow interrupt
0015H	Low-pulse width timer underflow interrupt
0018H	Port 6, Port 8 input status change wake up

## 6.9 LCD Driver

This LSI can drive an LCD of up to 32 segments and 4 commons that can drive a total of 4×32 dots. The LCD block is made up of an LCD driver, display RAM, segment output pins, common output pins, and LCD operating power supply pins. This circuit works on normal mode, green mode and idle mode. The LCD duty; bias; the number of segment; the number of common and frame frequency are determined by the LCD controller register.

The basic structure contains a timing control that uses a subsystem clock to generate the proper timing for different duty and display accesses. The R9 register is a command register for the LCD driver which includes LCD enable/disable, bias (1/2 and 1/3), duty (1/2, 1/3, 1/4), and LCD frame frequency control. The register RA is an LCD contrast and LCD RAM address control register. The register RB is an LCD RAM data buffer. LCD booster circuit can change the operation frequency to improve VLCD2 and VLCD3 drive capability. The control register is described as follows.

### 6.9.1 R9/LCDCR (LCD Control Register)

Bit 7	Bit 6	Bit 5	Bit 4	Bit 3	Bit 2	Bit 1	Bit 0
BS	DS1	DS0	LCDEN	–	LCDDTYPE	LCDF1	LCDF0
R/W	R/W	R/W	R/W	-	R/W	R/W	R/W

**Bit 7 (BS):** LCD bias select bit, 0/1=> (1/2 bias) / (1/3 bias)

**Bits 6 ~ 5 (DS1 ~ DS0):** LCD duty select

DS1	DS0	LCD Duty
0	0	1/2 duty
0	1	1/3 duty
1	×	1/4 duty

**Bit 4 (LCDEN):** LCD enable bit

"0": disable the LCD circuit

"1": enable the LCD circuit

When the LCD function is disabled, all common/segment output is set to ground (GND) level

**Bit 3:** Not used

**Bit 2 (LCDTYPE):** LCD drive waveform type select bit

**LCDTYPE = "0":** "A" type waveform

**LCDTYPE = "1":** "B" type waveform

**Bits 1 ~ 0 (LCDF1 ~ LCDF0):** LCD frame frequency control bits

LCDF1	LCDF0	LCD Frame Frequency (e.g. $F_s=32.768\text{kHz}$ )		
		1/2 Duty	1/3 Duty	1/4 Duty
0	0	$F_s/(256 \times 2)=64.0$	$F_s/(172 \times 3)=63.5$	$F_s/(128 \times 4)=64.0$
0	1	$F_s/(280 \times 2)=58.5$	$F_s/(188 \times 3)=58.0$	$F_s/(140 \times 4)=58.5$
1	0	$F_s/(304 \times 2)=53.9$	$F_s/(204 \times 3)=53.5$	$F_s/(152 \times 4)=53.9$
1	1	$F_s/(232 \times 2)=70.6$	$F_s/(156 \times 3)=70.0$	$F_s/(116 \times 4)=70.6$

*Note:*  $F_s$ : sub-oscillator frequency

### 6.9.2 RA/LCD\_ADDR (LCD Address)

Bit 7	Bit 6	Bit 5	Bit 4	Bit 3	Bit 2	Bit 1	Bit 0
0	0	0	LCD_A4	LCD_A3	LCD_A2	LCD_A1	LCD_A0
-	-	-	R/W	R/W	R/W	R/W	R/W

**Bits 7 ~ 5:** Not used, fixed to "0"

**Bits 4 ~ 0 (LCDA4 ~ LCDA0):** LCD RAM address

RA (LCD Address)	RB (LCD Data Buffer)					Segment
	Bits 7 ~4	Bit 3 (LCD_D3)	Bit 2 (LCD_D2)	Bit 1 (LCD_D1)	Bit 0 (LCD_D0)	
00H	-	-	-	-	-	SEG0
01H	-	-	-	-	-	SEG1
02H	-	-	-	-	-	SEG2
1DH	-	-	-	-	-	SEG29
1EH	-	-	-	-	-	SEG30
1FH	-	-	-	-	-	SEG31
Common	X	COM3	COM2	COM1	COM0	

### 6.9.3 RB/LCD\_DB (LCD Data Buffer)

Bit 7	Bit 6	Bit 5	Bit 4	Bit 3	Bit 2	Bit 1	Bit 0
-	-	-	-	LCD_D3	LCD_D2	LCD_D1	LCD_D0
-	-	-	-	R/W	R/W	R/W	R/W

**Bits 7 ~ 4:** Not used

**Bit 3 ~ 0 (LCD\_D3 ~ LCD\_D0):** LCD RAM data transfer registers

### 6.9.4 RD/SBPCR (System, Booster and PLL Control Registers)

Bit 7	Bit 6	Bit 5	Bit 4	Bit 3	Bit 2	Bit 1	Bit 0
–	CLK2	CLK1	CLK0	IDLE	BF1	BF0	CPUS
–	R/W	R/W	R/W	R/W	R/W	R/W	R/W

Bit 2 ~ 1 (BF1 ~ 0): LCD booster frequency select bits

BF1	BF0	Booster Frequency
0	0	Fs
0	1	Fs/4
1	0	Fs/8
1	1	Fs/16

The initial setting flowchart for LCD function

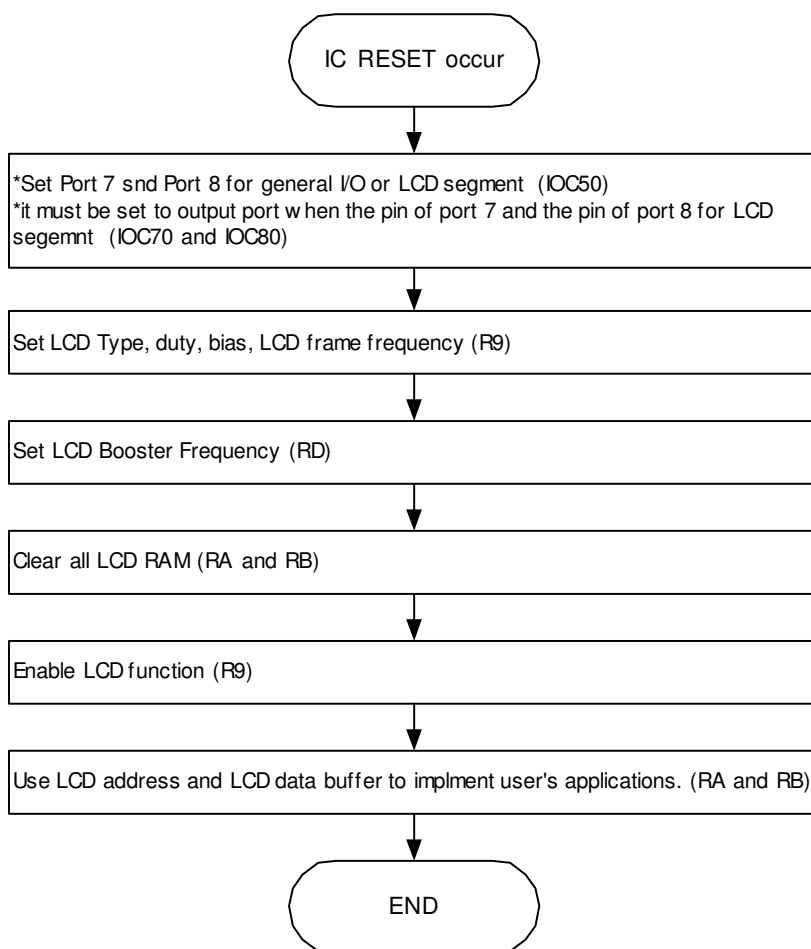
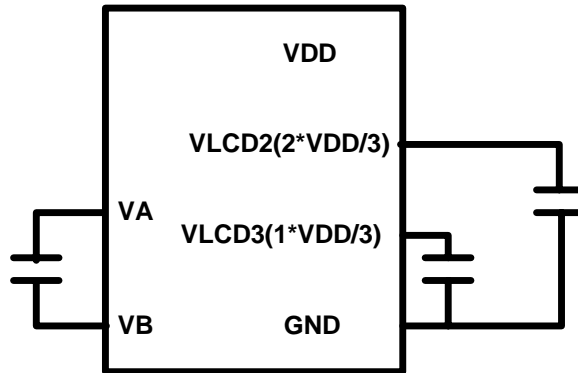
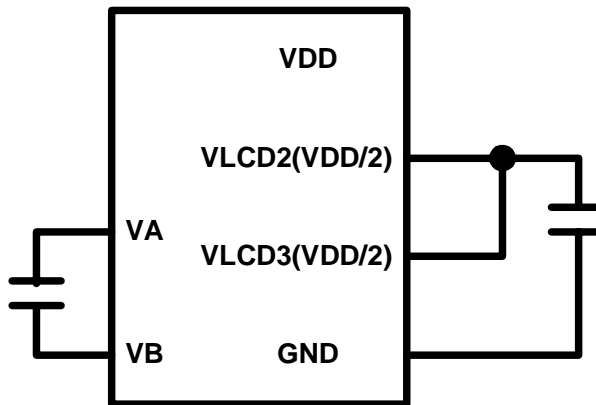

Figure 6-14 Initial Setting Flowchart for LCD Function

Boosting circuits connection for LCD voltage



External circuit for 1/3 Bias



External circuit for 1/2 Bias

Figure 6-15 Charge Bump Circuit Connection ( $C_{ext}=0.1\mu f$ )

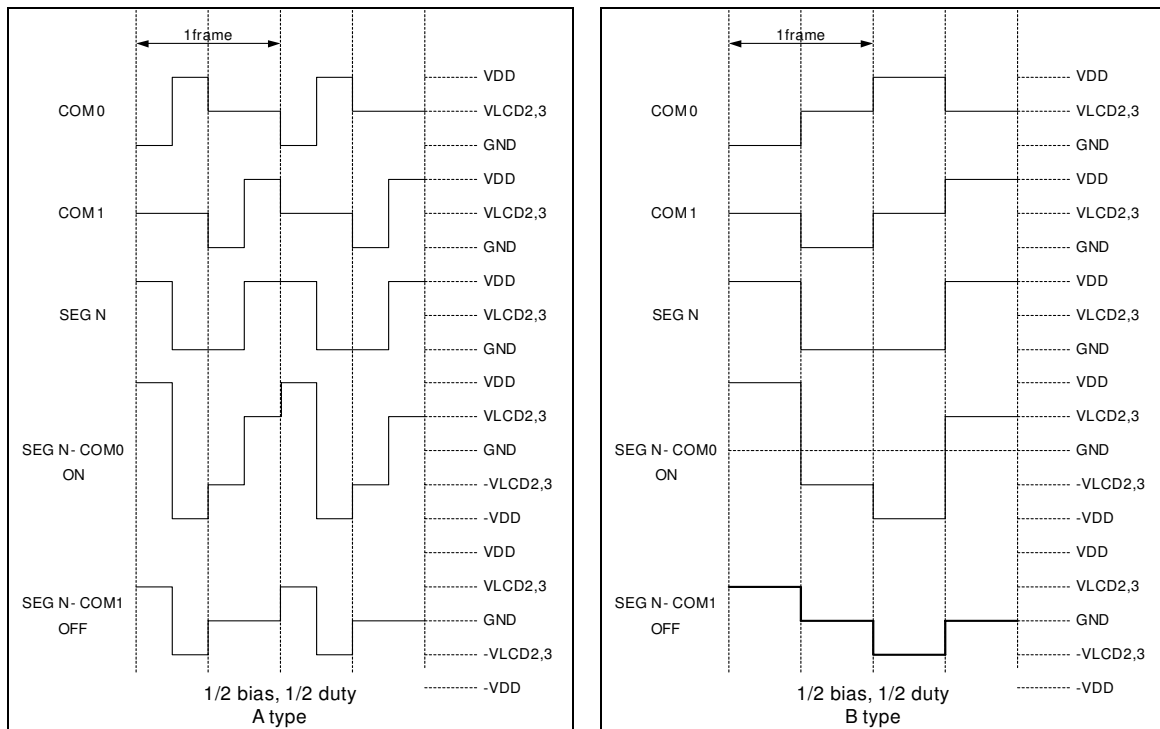

Figure 6-16 LCD Waveform for 1/2 Bias, 1/2 Duty

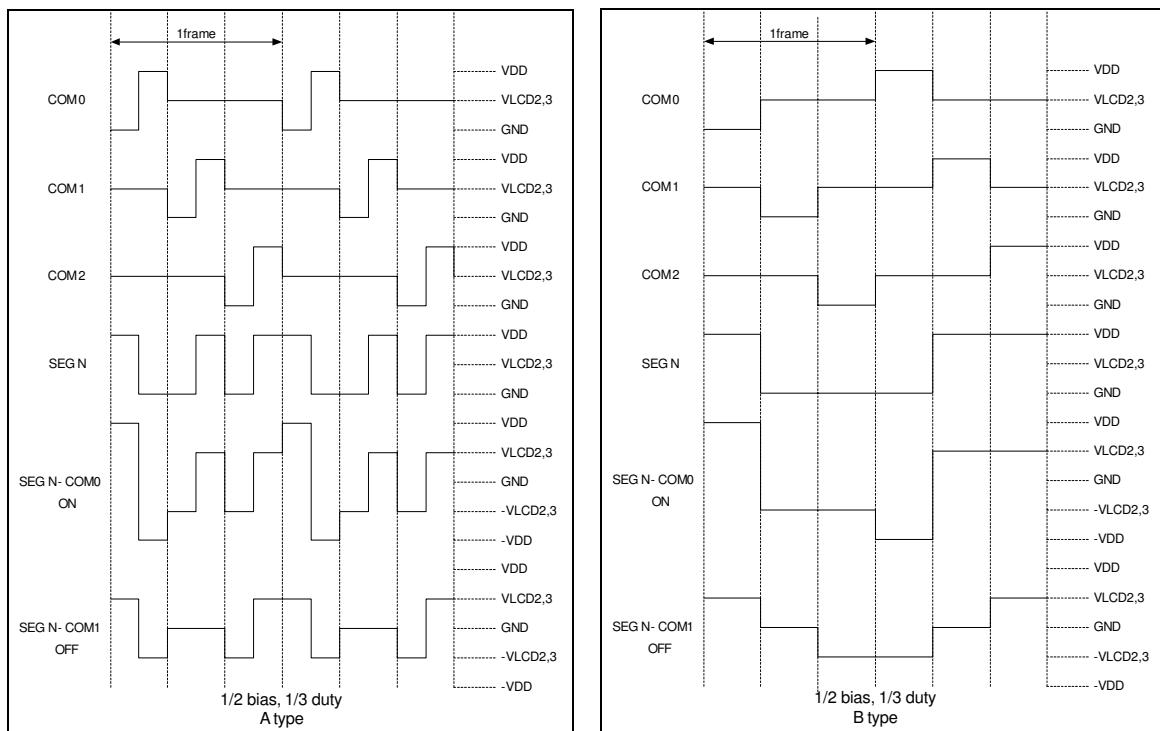

Figure 6-17 LCD Waveform for 1/2 Bias, 1/3 Duty

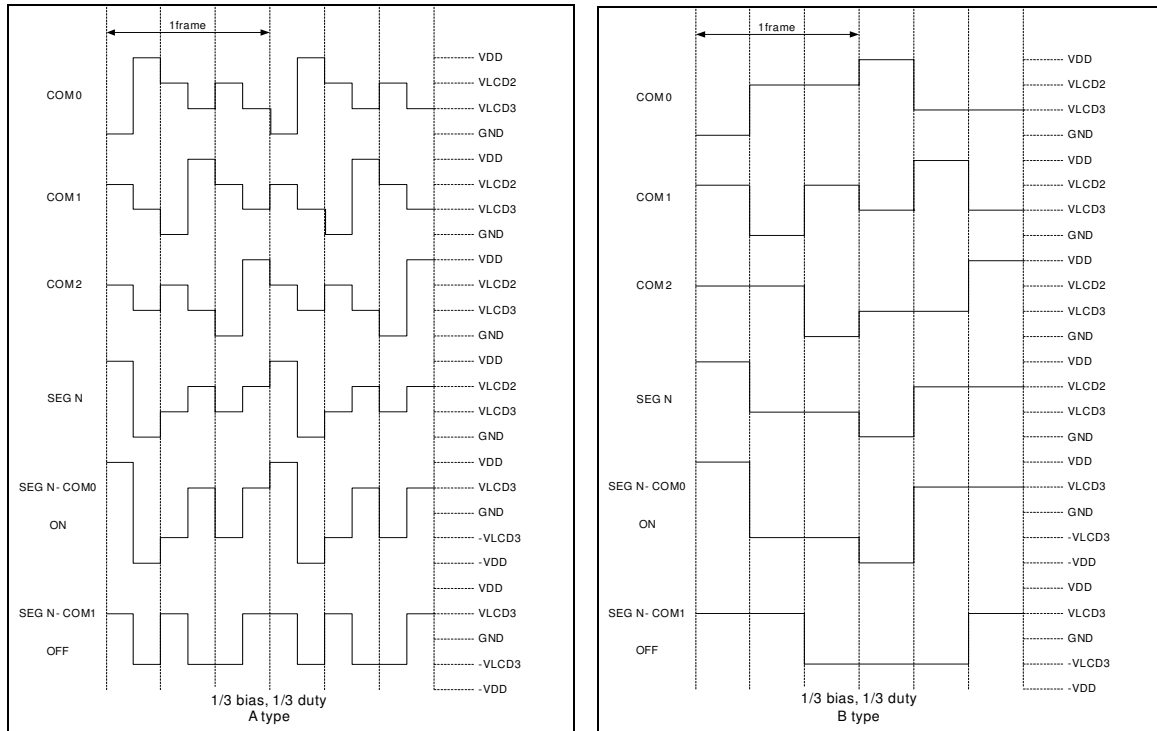

Figure 6-18 LCD Waveform for 1/3 Bias, 1/3 Duty

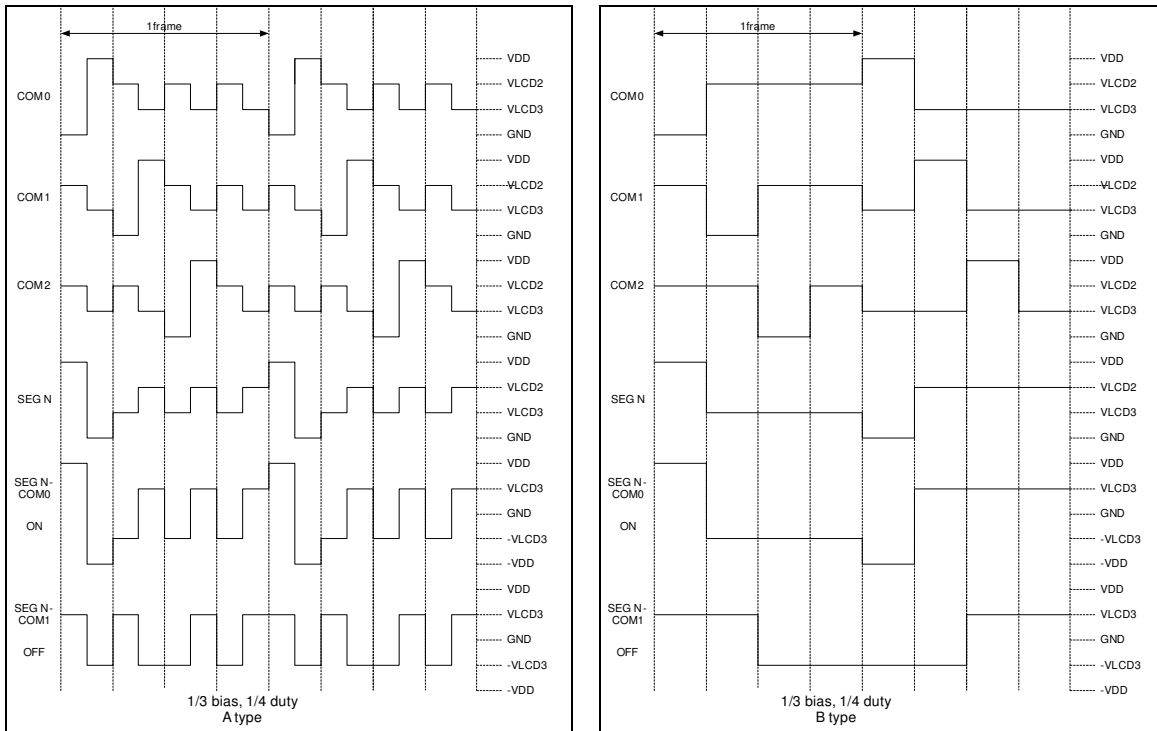

Figure 6-19 LCD Waveform for 1/3 Bias, 1/4 Duty

## 6.10 Infrared Remote Control Application/PWM Waveform Generation

This LSI can output infrared carrier in user-friendly or in PWM standard waveform. The IR and PWM waveform generated functions include an 8-bit down count timer/counter, high-pulse width timer, low-pulse width timer, and IR control register. The IR system block diagram is shown in Fig. 6-20. The IROUT pin waveform is determined by IR control register (RE), IOC90 (Counters 1 and 2 control register), IOCA0 (high-pulse width timer, low-pulse width timer control register), IOCC0 (Counter 2 preset), IOCD0 (high-pulse width timer preset register), and IOCE0 (low-pulse width timer preset register). Details on  $F_{carrier}$ , high-pulse time, and low pulse time are explained as follows:

If Counter 2 clock source is  $F_T$  (this clock source can be set by IOC91), then

$$F_{carrier} = \frac{F_T}{2 \times (1 + \text{decimal of Counter 2 preset value (IOCC 0)}) \times \text{prescaler}}$$

If the high-pulse width timer clock source is  $F_T$  (this clock source can be set by IOCA1), then

$$T_{high\ pulse\ time} = \frac{\text{prescaler} \times (1 + \text{decimal of high pulse width timer value (IOCD 0)})}{F_T}$$

If the low-pulse width timer clock source is  $F_T$  (this clock source can be set by IOCA1);

$$T_{low\ pulse\ time} = \frac{\text{prescaler} \times (1 + \text{decimal of low pulse width timer value (IOCE 0)})}{F_T}$$

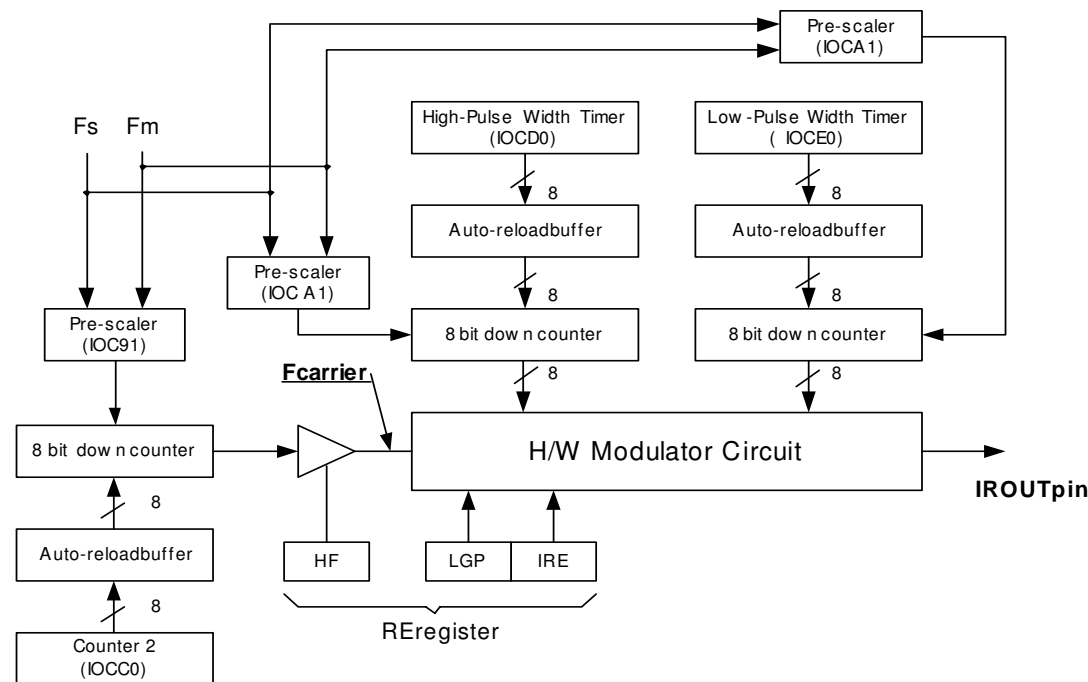

**$F_m$** : main oscillator frequency     **$F_s$** : sub-oscillator frequency

Figure 6-20 IR/PWM System Block Diagram

The IROUT output waveform is further explained in the following figures:

**Figure 6-21** LGP=0, HF=1, the IROUT waveform can modulate Fcarrier waveform when in low-pulse width time.

**Figure 6-22** LGP=0, HF=0, the IROUT waveform cannot modulate Fcarrier waveform when in low-pulse width time. So IROUT waveform is determined by high-pulse time and low-pulse time. This mode can produce standard PWM waveform.

**Figure 6-23** LGP=0, HF=1, the IROUT waveform can modulate Fcarrier waveform when in low-pulse width time. When IRE goes from high to low, the output waveform of IROUT will keep on transmitting until high-pulse width timer interrupt occurs.

**Figure 6-24** LGP=0, HF=0, the IROUT waveform can not modulate Fcarrier waveform when in low-pulse width time. So IROUT waveform is determined by high-pulse time and low-pulse time. This mode can produce standard PWM waveform. When IRE goes from high to low, the output waveform of IROUT will keep on transmitting till high-pulse width timer interrupt occurs.

**Figure 6-25** LGP=1, when this bit is set to high level, the high-pulse width timer is ignored. So IROUT waveform output from low-pulse width timer is established.

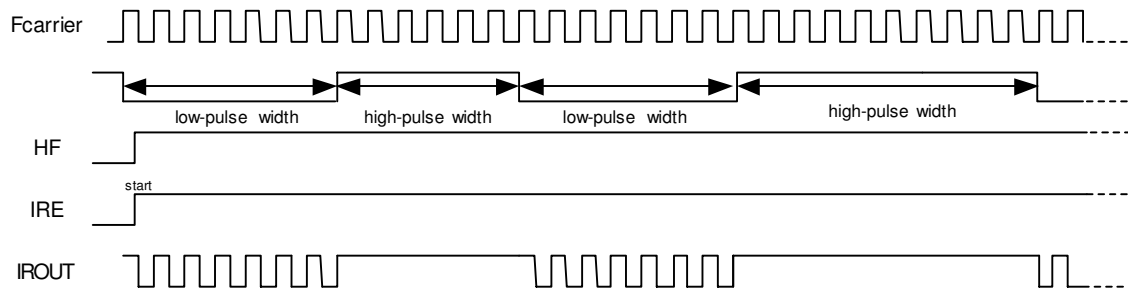

Figure 6-21 LGP=0, IROUT Pin Output Waveform

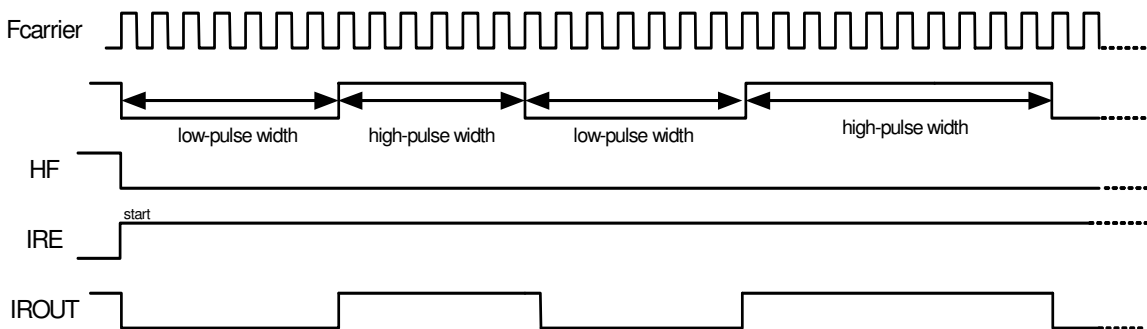

Figure 6-22 LGP=0, IROUT Pin Output Waveform

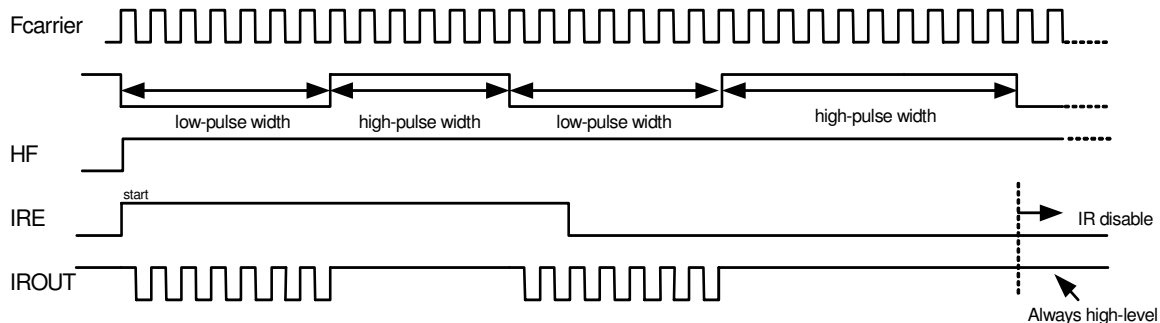

Figure 6-23 L<sub>GP</sub>=0, IROUT Pin Output Waveform

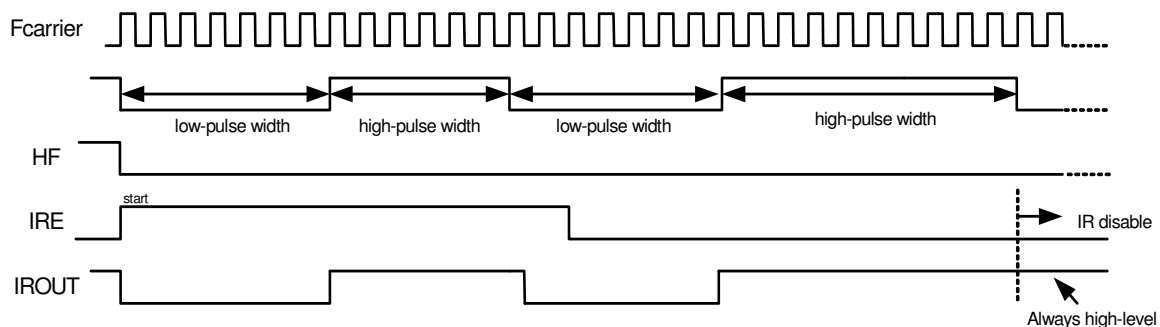

Figure 6-24 L<sub>GP</sub>=0, IROUT Pin Output Waveform

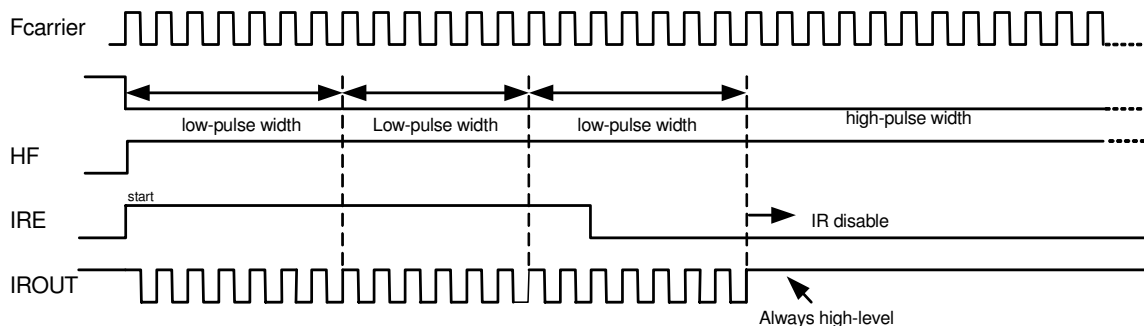

Figure 6-25 L<sub>GP</sub>=1, IROUT Pin Output Waveform

**IR/PWM Function Enable Flowchart**

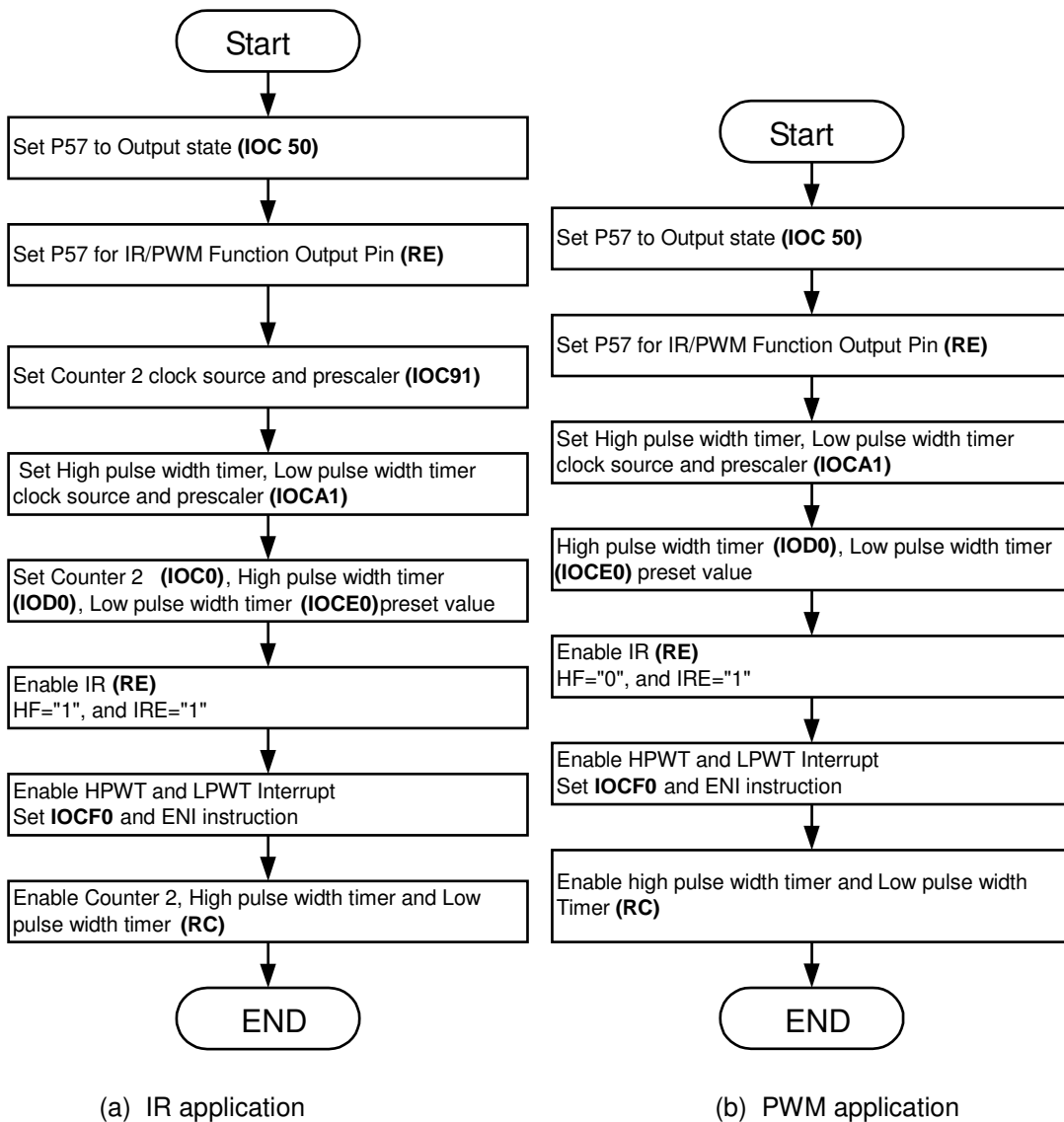

Figure 6-26 IR/PWM Function Enable Flowchart

## 6.11 Code Options

The EM78P468B has one Code Option word that is not a part of the normal program memory. The option bits cannot be accessed during normal program execution.

Code Option Register and Customer ID Register arrangement distribution:

Word 1 of the code options is for customer ID code application.

Word 1
Bit 12~Bit 0

Word 0 of Code Options is for IC function setting. The following are the settings for OTP IC programming:

Mnemonic	Bits 12 ~ 10	Bit 9	Bit 8	Bit 7	Bit 6	Bit 5	Bit 4	Bit 3	Bits 2 ~ 0
	–	CYES	HLFS	ENWDTB	FSMD	FMMD1	FMMD0	–	PR2 ~ 0
1	–	High	High	Disable	High	High	High	–	Disable
0	–	Low	Low	Enable	Low	Low	Low	–	Enable
Default	1	1	1	1	1	1	1	0	1

**Bits 12 ~ 10:** Not used.

These bits are set to "1" all the time.

**Bit 9 (CYES):** Cycle select for JMP and CALL instructions

**CYES = "0":** only one instruction cycle (JMP or CALL) can be executed

**CYES = "1":** two instruction cycles (JMP and CALL) can be executed

**Bit 8 (HLFS):** main or sub-oscillator select

**HLFS = "0":** CPU is set to select sub-oscillator when reset occurs.

**HLFS = "1":** CPU is set to select main-oscillator when reset occurs.

**Bit 7 (ENWDTB):** Watchdog timer enable/disable bit.

**ENWDTB = "0":** Enable watchdog timer

**ENWDTB = "1":** Disable watchdog timer

**Bit 6 (FSMD):** Sub-oscillator type selection

**Bits 5, 4 (FMMD1, 0): Main Oscillator Type Selection**

FSMD	FMMD1	FMMD0	Main Oscillator Type	Sub Oscillator Type
0	0	0	RC type	RC type
0	0	1	Crystal type	RC type
0	1	×	PLL type	RC type
1	0	0	RC type	Crystal type
1	0	1	Crystal type	Crystal type
1	1	×	PLL type	Crystal type

**Bit 3:** Not used

These bits are set to "0" all the time.

**Bits 2~0 (PR2~PR0): Protect Bit**

PR2~PR0 are protection bits. Each protect status is as follows:

PR2	PR1	PR0	Protect
0	0	0	Enable
1	1	1	Disable

## 6.12 Instruction Set

Each instruction in the instruction set is a 13-bit word divided into an OP code and one or more operands. Normally, all instructions are executed within one single instruction cycle (one instruction consists of 2 oscillator periods), unless the program counter is changed by instruction "MOV R2,A", "ADD R2,A", or by instructions of arithmetic or logic operation on R2 (e.g. "SUB R2,A", "BS(C) R2,6", "CLR R2", ...). In this case, the execution takes two instruction cycles.

If for some reasons, the specification of the instruction cycle is not suitable for certain applications, try modifying the instruction as follows:

Execute within two instruction cycles the "JMP", "CALL", "RET", "RETL", and "RETI" instructions, or the conditional skip instructions ("JBS", "JBC", "JZ", "JZA", "DJZ", "DJZA") which were tested to be true. Also execute within two instruction cycles the instructions that are written to the program counter.

Additionally, the instruction set offers the following features:

- (1) Every bit of any register can be set, cleared, or tested directly.
- (2) The I/O register can be regarded as general register. That is, the same instruction can operate on I/O register.

**Convention:**

*R* = Register designator that specifies which one of the registers (including operation and general purpose registers) is to be utilized by the instruction.

*b* = Bit field designator that selects the value for the bit located in the register *R* and which affects the operation.

*k* = 8 or 10-bit constant or literal value

Mnemonic	Operation	Status Affected
NOP	No Operation	None
DAA	Decimal Adjust A	C
SLEP	0 → WDT, Stop oscillator	T, P
WDTC	0 → WDT	T, P
IOW        R	A → IOCR	None <sup>1</sup>
ENI	Enable Interrupt	None
DISI	Disable Interrupt	None
RET	[Top of Stack] → PC	None
RETI	[Top of Stack] → PC, Enable Interrupt	None
IOR        R	IOCR → A	None <sup>1</sup>
MOV        R, A	A → R	None
CLRA	0 → A	Z
CLR        R	0 → R	Z
SUB        A, R	R-A → A	Z,C,DC
SUB        R, A	R-A → R	Z,C,DC
DECA	R-1 → A	Z
DEC        R	R-1 → R	Z
OR         A, R	A ∨ R → A	Z
OR         R, A	A ∨ R → R	Z
AND        A, R	A & R → A	Z
AND        R, A	A & R → R	Z
XOR        A, R	A ⊕ R → A	Z
XOR        R, A	A ⊕ R → R	Z
ADD        A, R	A + R → A	Z, C, DC
ADD        R, A	A + R → R	Z, C, DC
MOV        A, R	R → A	Z
MOV        R, R	R → R	Z
COMA	/R → A	Z
COM	/R → R	Z
INCA	R+1 → A	Z
INC	R+1 → R	Z
DJZA	R-1 → A, skip if zero	None
DJZ	R-1 → R, skip if zero	None

Mnemonic		Operation	Status Affected
RRCA	R	$R(n) \rightarrow A(n-1)$ , $R(0) \rightarrow C$ , $C \rightarrow A(7)$	C
RRC	R	$R(n) \rightarrow R(n-1)$ , $R(0) \rightarrow C$ , $C \rightarrow R(7)$	C
RLCA	R	$R(n) \rightarrow A(n+1)$ , $R(7) \rightarrow C$ , $C \rightarrow A(0)$	C
RLC	R	$R(n) \rightarrow R(n+1)$ , $R(7) \rightarrow (C)$ , $C \rightarrow (R(0))$	C
SWAPA	R	$R(0-3) \rightarrow (A(4-7))$ , $R(4-7) \rightarrow (A(0-3))$	None
SWAP	R	$R(0-3) \rightarrow (R(4-7))$	None
JZA	R	$R+1 \rightarrow A$ , skip if zero	None
JZ	R	$R+1 \rightarrow R$ , skip if zero	None
BC	R, b	$0 \rightarrow (R(b))$	None
BS	R, b	$1 \rightarrow (R(b))$	None
JBC	R, b	if $R(b)=0$ , skip	None
JBS	R, b	if $R(b)=1$ , skip	None
CALL	k	$PC+1 \rightarrow [SP]$ , $(Page, k) \rightarrow (PC)$	None
JMP	k	$(Page, k) \rightarrow (PC)$	None
MOV	A, k	$k \rightarrow A$	None
OR	A, k	$A \vee k \rightarrow A$	Z
AND	A, k	$A \& k \rightarrow A$	Z
XOR	A, k	$A \oplus k \rightarrow A$	Z
RETL	k	$k \rightarrow A$ , [Top of Stack] $\rightarrow PC$	None
SUB	A, k	$k-A \rightarrow A$	Z, C, DC
ADD	A, k	$k+A \rightarrow A$	Z, C, DC
PAGE	k	$K \rightarrow R3(5:6)$	None
BANK	k	$K \rightarrow R4(7:6)$	None

**Note:** <sup>1</sup>This instruction is applicable to IOC50~IOF0, IOC61~IOCE1.

## 6.13 Timing Diagram

### AC Test Input/Output Waveform

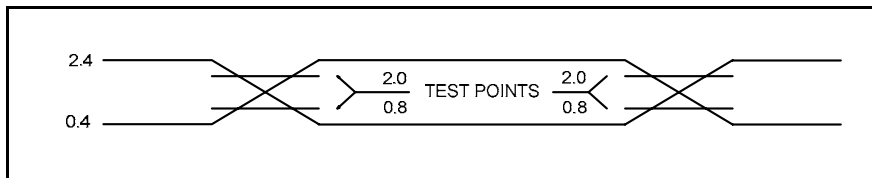

**Note:** AC Testing: Input are driven at 2.4V for logic "1," and 0.4V for logic "0"  
Timing measurements are made at 2.0V for logic "1," and 0.8V for logic "0"

### Reset Timing (CLK="0")

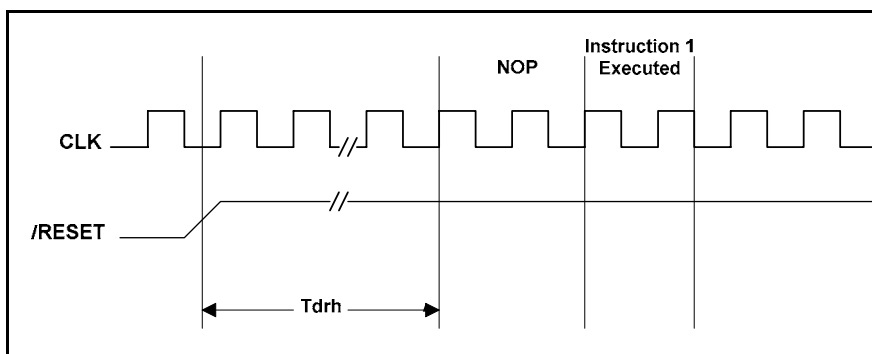

### TCC Input Timing (CLKS="0")

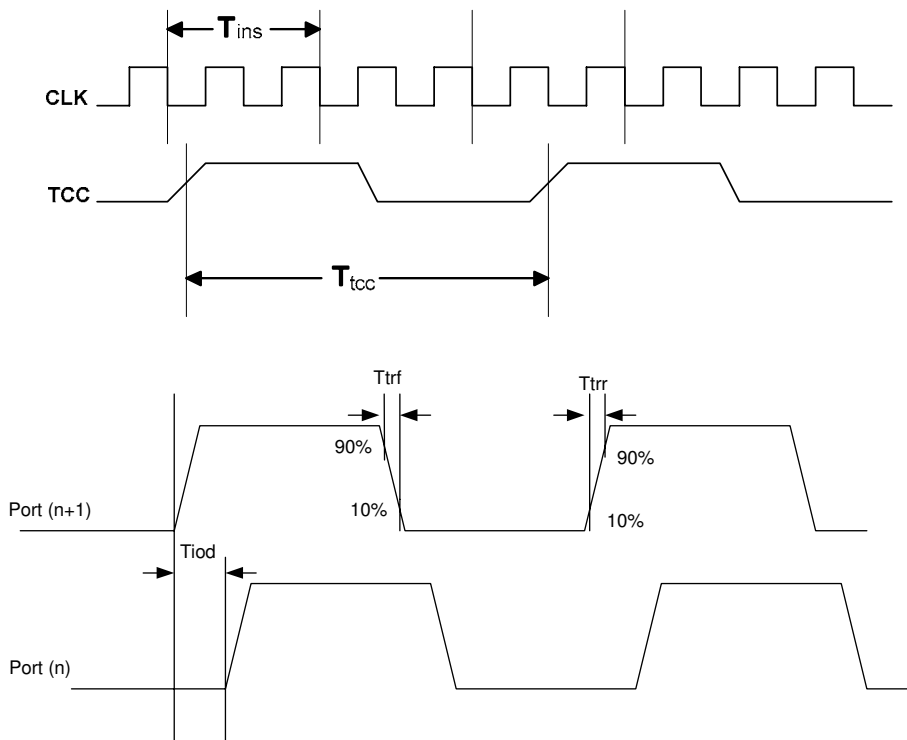

\*n = 0, 2, 4, 6

Figure 6-27 Timing Diagrams of EM78P468B

## 7 Absolute Maximum Ratings

Items	Symbol	Condition	Rating		Unit
			Min.	Max.	
Supply voltage	VDD	–	GND-0.3	+7.0	V
Input voltage	V <sub>I</sub>	Port 5 ~ Port 8	GND-0.3	VDD+0.3	V
Output voltage	V <sub>O</sub>	Port 5 ~ Port 8	GND-0.3	VDD+0.3	V
Operation temperature	T <sub>OPR</sub>	–	-40	85	°C
Storage temperature	T <sub>STG</sub>	–	-65	150	°C
Power consumption	P <sub>D</sub>	–	–	500	mW
Operating Frequency	–	–	32.768K	10M	Hz

## 8 Electrical Characteristics

### 8.1 DC Electrical Characteristics

T<sub>a</sub>= -40°C ~85°C, VDD=5.0V, GND=0V

Symbol	Parameter	Condition	Min.	Typ.	Max.	Unit
FXT	Crystal: VDD to 5V	Two cycles with two clocks	32.768	8M	10M	kHz
Fs	Sub-oscillator	Two cycles with two clocks	–	32.768	–	kHz
ERIC	External R, Internal C for Sub-oscillator	R: 300KΩ, internal capacitance	270	384	500	kHz
	External R, Internal C for Sub-oscillator	R: 2.2MΩ, internal capacitance	22.9	32.768	42.6	kHz
IIL	Input Leakage Current for Input pins	V <sub>IN</sub> = VDD, GND	-1	0	1	μA
VIH1	Input High Threshold Voltage (Schmitt Trigger)	Ports 5, 6, 7, 8	2.0	–	–	V
VIL1	Input High Threshold Voltage (Schmitt Trigger)	Ports 5, 6, 7, 8	–	–	0.8	V
VIHT1	Input High Threshold Voltage (Schmitt Trigger)	/RESET	2.0	–	–	V
VILT1	Input Low Threshold Voltage (Schmitt Trigger)	/RESET	–	–	0.8	V
VIHT2	Input High Threshold Voltage (Schmitt Trigger)	TCC, INT0, INT1	2.0	–	–	V
VILT2	Input Low Threshold Voltage (Schmitt Trigger)	TCC, INT0, INT1	–	–	0.8	V
IOH1	High Drive Current (Ports 5 ~ 8)	VOH = 2.4V (IROCS="0")	–	-10	–	mA
IOL1	Low Sink Current (Ports 5 and 6)	VOL = 0.4V (IROCS="0")	–	10	–	mA
IOH2	High Drive Current (Ports 5 ~ 8)	VOH = 2.4V (IROCS="1")	–	20	–	mA
IOL2	Low Sink Current (Ports 5 and 6)	VOL = 0.4V (IROCS="1")	–	20	–	mA

Ta= -40°C ~85°C, VDD=5.0V, GND=0V

Symbol	Parameter	Condition	Min.	Typ.	Max.	Unit
IPH	Pull-high current	Pull-high active, input pin at GND	-55	-75	-95	μA
IPL	Pull-low current	Pull-low active, input pin at VDD	55	75	95	μA
ISB	Sleep mode current	All input and I/O pins at VDD, Output pin floating, WDT disabled	–	0.5	1.5	μA
ICC1	Idle mode current	/RESET= 'High', CPU OFF, Sub-oscillator clock (32.768kHz) ON, output pin floating, LCD enabled, no load	–	14	18	μA
ICC2	Green mode current	/RESET= 'High', CPU ON, Sub-oscillator clock (32.768kHz), Output pin floating, WDT enabled, LCD enabled	–	22	30	μA
ICC3	Normal mode	/RESET= 'High', Fosc = 4 MHz (Crystal type, CLKS="0"), Output pin floating	–	2.2	3	mA
ICC4	Normal mode	/RESET= 'High', Fosc = 10 MHz (Crystal type, CLKS="0"), Output pin floating	–	3.1	4	mA

Ta= -40°C ~85°C, VDD=3.0V, GND=0V

Symbol	Parameter	Condition	Min.	Typ.	Max.	Unit
FXT	Crystal: VDD to 5V	Two cycles with two clocks	32.768	8M	10M	kHz
Fs	Sub-oscillator	Two cycles with two clocks	–	32.768	–	kHz
ERIC	External R, Internal C for Sub-oscillator	R: 300KΩ, internal capacitance	270	384	500	kHz
	External R, Internal C for Sub-oscillator	R: 2.2MΩ, internal capacitance	22.9	32.768	42.6	kHz
IIL	Input Leakage Current for Input pins	VIN = VDD, GND	-1	0	1	μA
VIH1	Input High Threshold Voltage (Schmitt Trigger)	Ports 5, 6, 7, 8	1.8	–	–	V
VIL1	Input High Threshold Voltage (Schmitt Trigger)	Ports 5, 6, 7, 8	–	–	0.6	V
VIHT1	Input High Threshold Voltage (Schmitt Trigger)	/RESET	1.8	–	–	V
VILT1	Input Low Threshold Voltage (Schmitt Trigger)	/RESET	–	–	0.6	V
VIHT2	Input High Threshold Voltage (Schmitt Trigger)	TCC, INT0, INT1	1.8	–	–	V
VILT2	Input Low Threshold Voltage (Schmitt Trigger)	TCC, INT0, INT1	–	–	0.6	V
IOH1	Output High Voltage (Ports 5~8)	VOH = 2.4V, IROCS="0"	–	-1.8	–	mA
IOL1	Output Low Voltage (Ports 5~8)	VOL = 0.4V, IROCS="0"	–	6	–	mA

Ta= -40°C ~85°C, VDD=3.0V, GND=0V

Symbol	Parameter	Condition	Min.	Typ.	Max.	Unit
IOH2	Output high voltage (P57/IROUT pin)	VOH = 2.4V, IROCS="1"	-	-3.5	-	mA
IOL2	Output Low Voltage (P57/IR OUT pin)	VOL = 0.4V, IROCS="1"	-	12	-	mA
IPH	Pull-high current	Pull-high active, input pin at GND	-16	-23	-30	μA
IPL	Pull-low current	Pull-low active, input pin at VDD	16	23	30	μA
ISB	Sleep mode current	All input and I/O pins at VDD, Output pin floating, WDT disabled	-	0.1	1	μA
ICC1	Idle mode current	/RESET= 'High', CPU OFF, Sub-oscillator clock (32.768kHz) ON, Output pin floating, LCD enabled, no load	-	4	8	μA
ICC2	Green mode current	/RESET= 'High', CPU ON, Sub-oscillator clock (32.768kHz), Output pin floating, WDT enabled, LCD enabled	-	10	20	μA
ICC3	Normal mode	/RESET= 'High', Fosc = 4 MHz (Crystal type, CLKS="0"), Output pin floating	-	0.73	1.2	mA

## 8.2 AC Electrical Characteristics

Ta= -40°C ~ 85°C, VDD=5V±5%, GND=0V

Symbol	Parameter	Conditions	Min	Typ	Max	Unit
Dclk	Input CLK duty cycle	-	45	50	55	%
Tins	Instruction cycle time (CLKS="0")	Crystal type	100	-	DC	ns
		RC type	500	-	DC	ns
Ttcc	TCC input period	-	(Tins+20)/N*	-	-	ns
Tdrh	Device reset hold time	Ta = 25°C	11.3	16.2	21.6	ms
Trst	/RESET pulse width	Ta = 25°C	2000	-	-	ns
Twdt	Watchdog timer period	Ta = 25°C	11.3	16.2	21.6	ms
Tset	Input pin setup time	-	-	0	-	ns
Thold	Input pin hold time	-	-	20	-	ns
Tdelay	Output pin delay time	Cload=20pF	-	50	-	ns

\*N= selected prescaler ratio

## APPENDIX

### A Ordering and Manufacturing Information

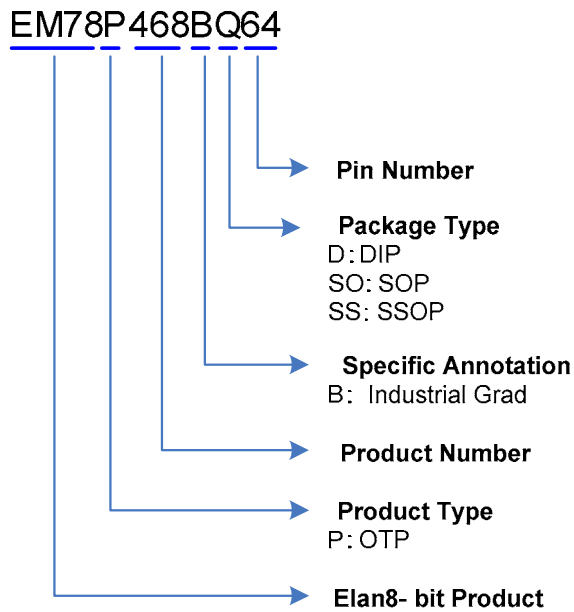

For example

**EM78P468BQ64**

is EM78P468B with OTP program memory, industrial grade product,  
in 64-pin QFP package

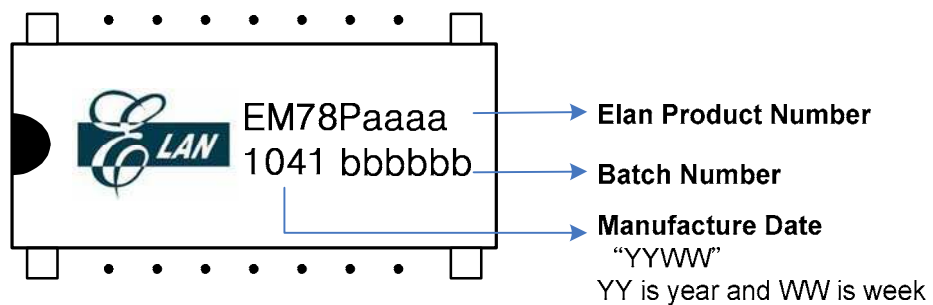

## B Package Type

Name	Package Type	Pin Count	Package Size
EM78P468BH	Dice	59	–
EM78P468BQ64	QFP	64	14 mm × 20 mm
EM78P468BL64	LQFP	64	7 mm × 7 mm
EM78P468BL44	LQFP	44	10 mm × 10 mm
EM78P468BQ44	QFP	44	10 mm × 10 mm
EM78P468BQ64B	QFP	64	14 mm × 14 mm

**Note:** These are Green products that do not contain hazardous substances.

These are compatible with the third edition of Sony SS-00259 standard.

The Pb content should be less than 100ppm, and should meet Sony specifications or requirements.

Part No.	EM78P468BxS/xJ
Electroplate type	Pure Tin
Ingredient (%)	Sn:100%
Melting point (°C)	232°C
Electrical resistivity (μΩ-cm)	11.4
Hardness (hv)	8~10
Elongation (%)	>50%

## C Package Information

### QFP – 64

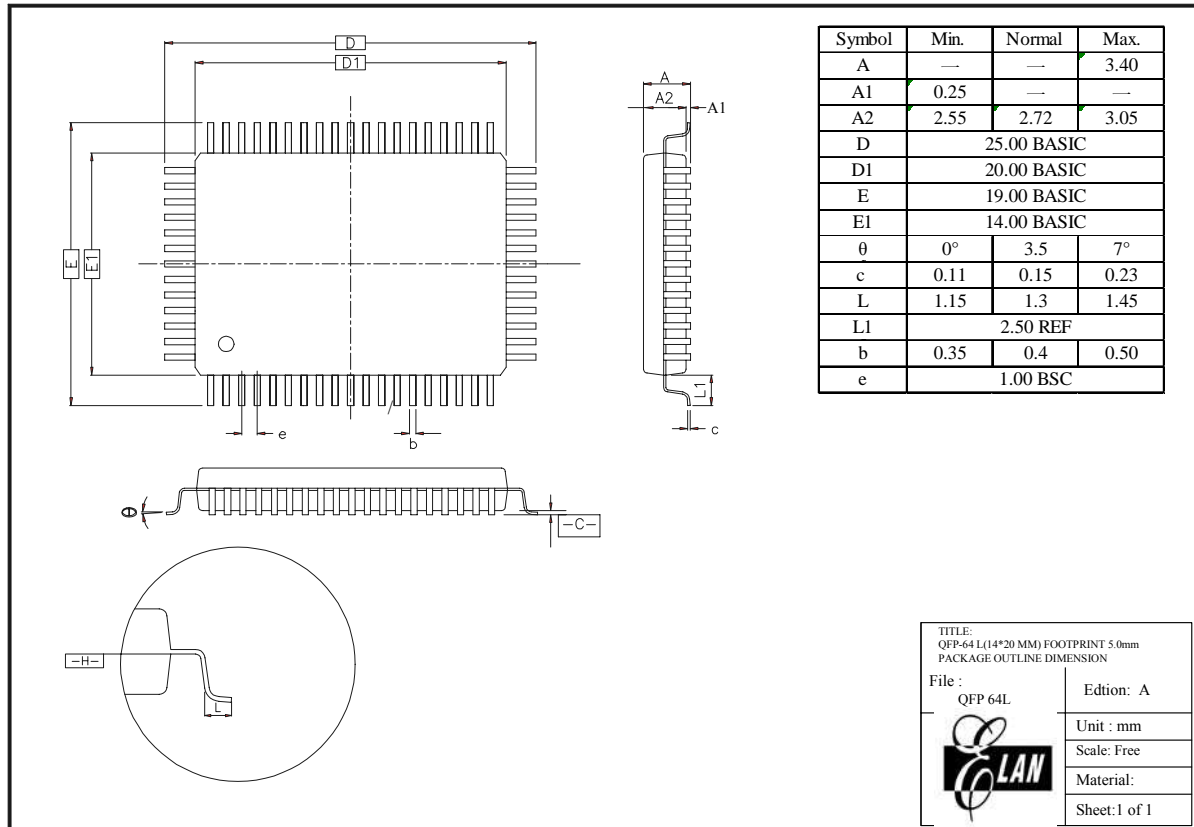

**QFP – 64**

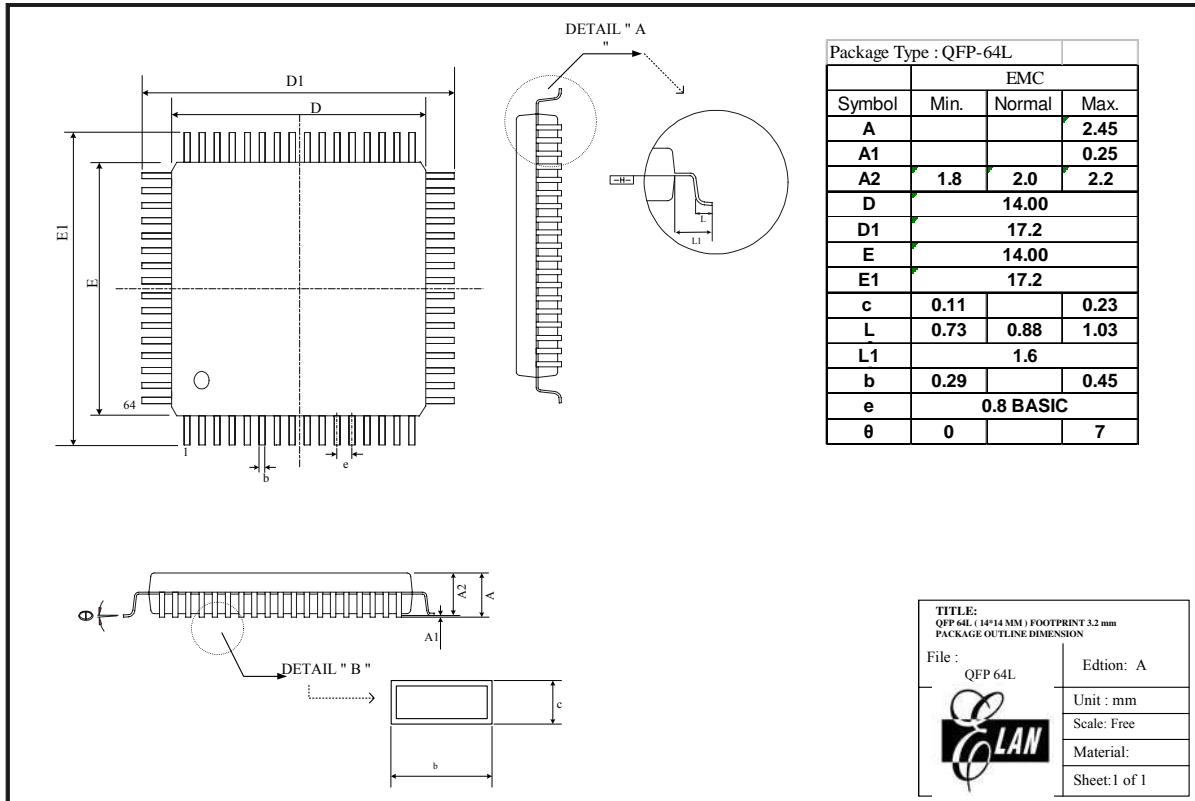

**LQFP – 64**

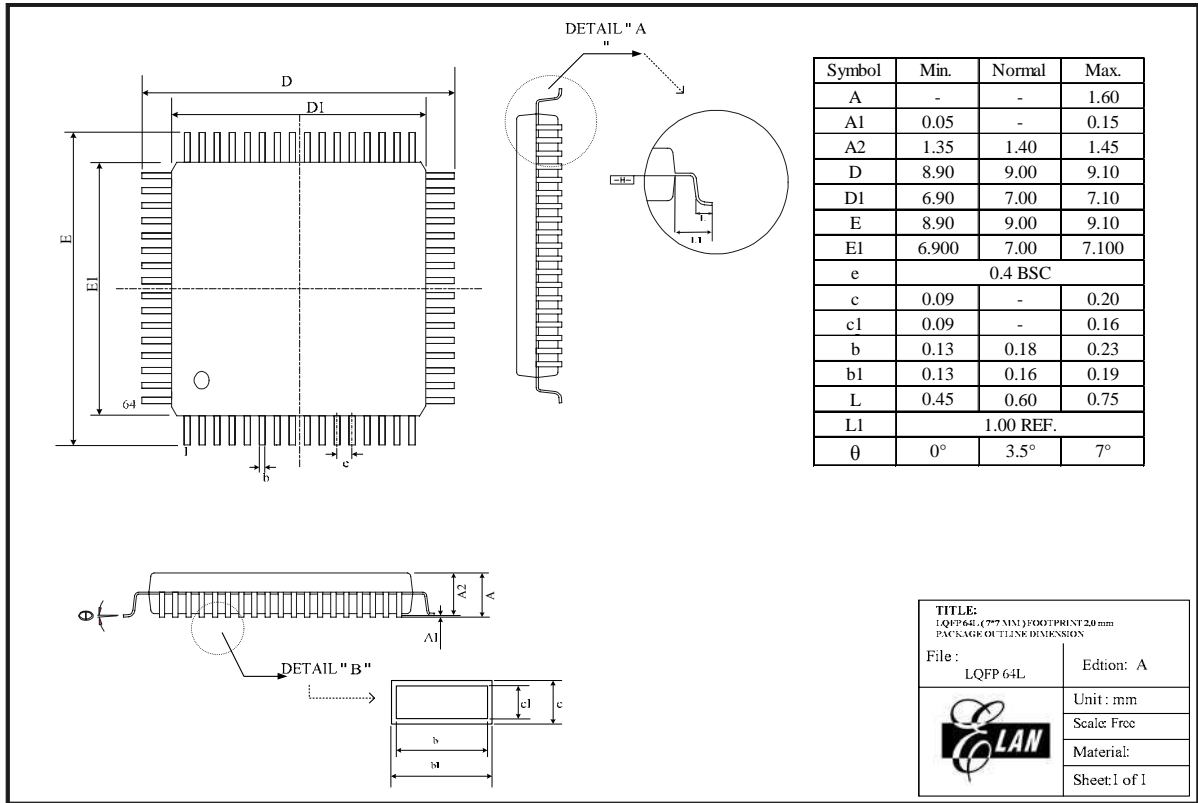

**LQFP – 44**

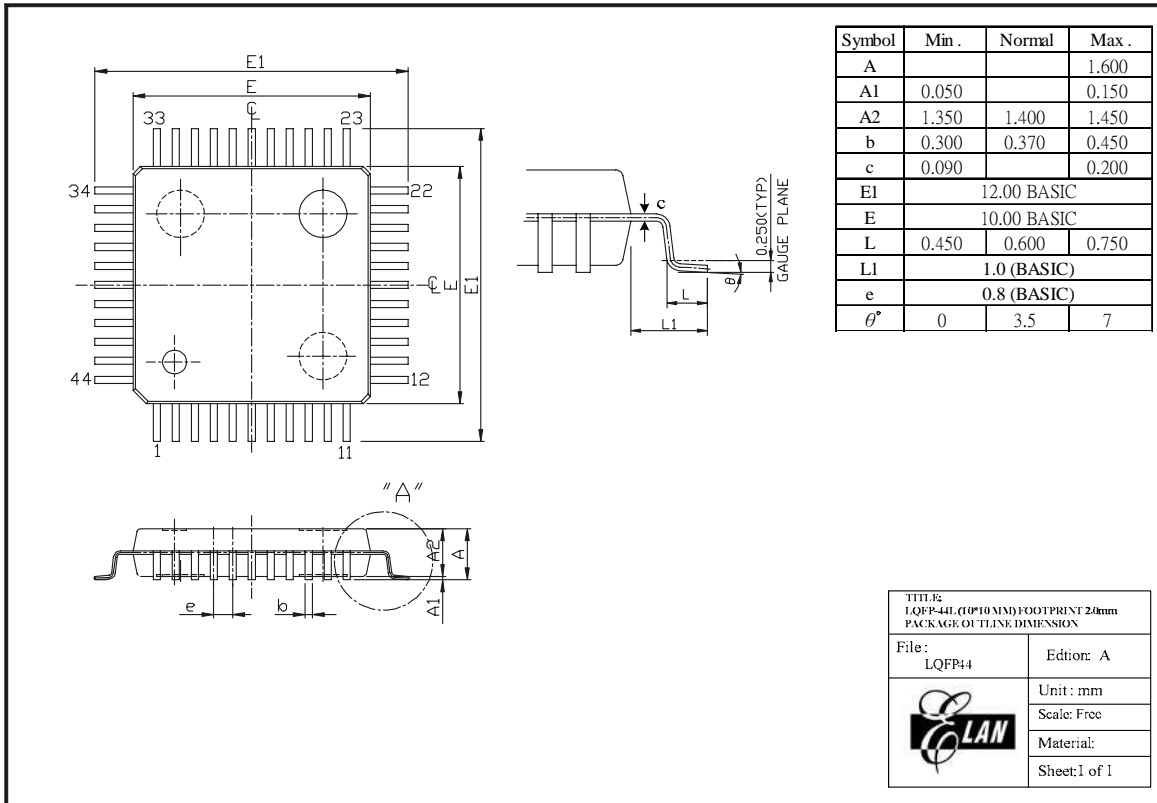

**QFP – 44**

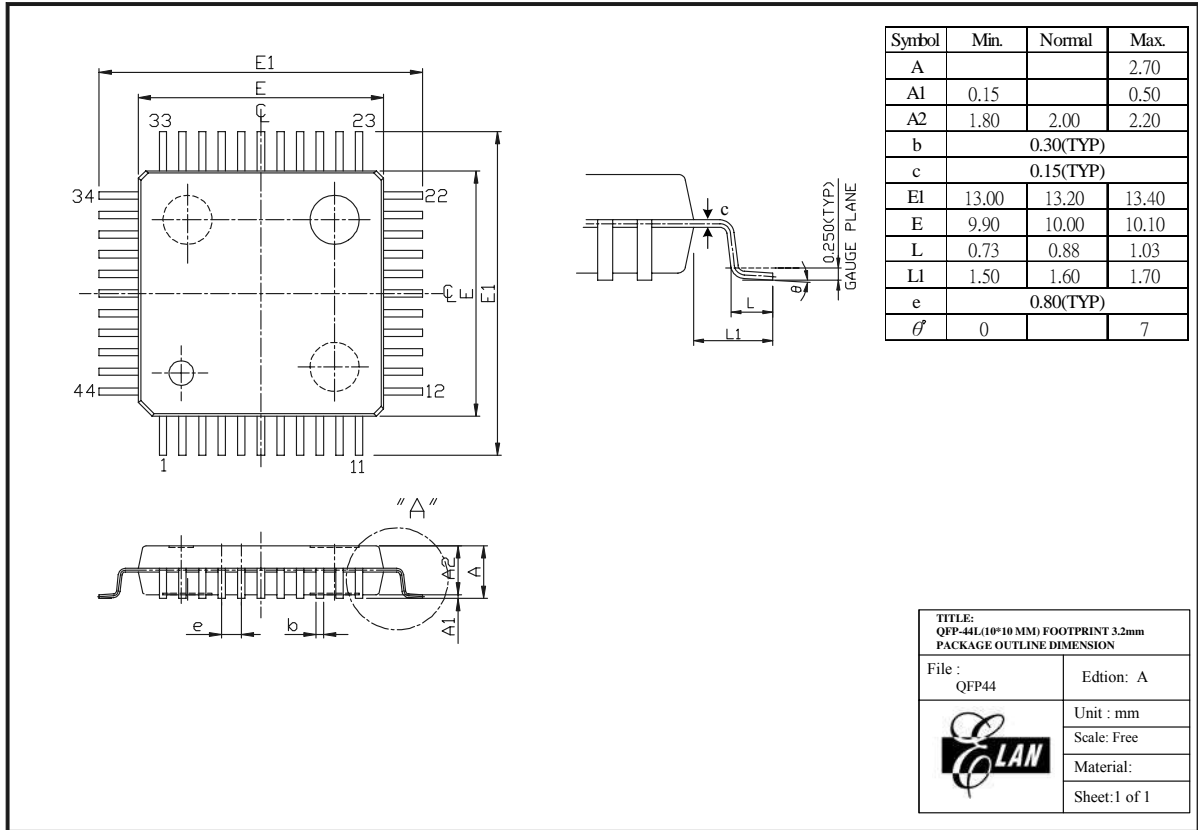



## D EM78P468B Program Pin List

Program Pin Name	IC Pin Name	L/QFP-64 Pin Number	L/QFP-44 Pin Number
VPP	/RESET	25	14
ACLK	P54/INT0	32	21
DINCLK	P55/INT1	33	22
DATAIN	P56/TCC	34	23
/PGMB	P60	38	25
/OEB	P61	39	26
VDD	VDD	29	18
GND	GND	26	15

## E Quality Assurance and Reliability

Test Category	Test Conditions	Remarks
Solderability	Solder temperature=245±5°C, for 5 seconds up to the stopper using a rosin-type flux	–
Pre-condition	Step 1: TCT, 65°C (15 min)~150°C (15mins), 10 cycles	For SMD IC (such as SOP, QFP, SOJ, etc)
	Step 2: Bake at 125°C, TD (endurance)=24 hrs	
	Step 3: Soak at 30°C/60% · TD (endurance)=192 hrs	
	Step 4: IR flow 3 cycles (Pkg thickness ≥ 2.5 mm or Pkg volume ≥ 350 mm <sup>3</sup> ----225 ± 5°C) (Pkg thickness ≤ 2.5 mm or Pkg volume ≤ 350 mm <sup>3</sup> ----240 ± 5°C)	
Temperature cycle test	-65°C (15mins)~150°C (15 min), 200 cycles	–
Pressure cooker test	TA =121°C, RH=100%, pressure=2 atm, TD (endurance)= 96 hrs	–
High temperature / High humidity test	TA=85°C, RH=85% · TD (endurance) = 168, 500 hrs	–
High-temperature storage life	TA=150°C, TD (endurance) = 500, 1000 hrs	–
High-temperature operating life	TA=125°C, VCC = Max. operating voltage, TD (endurance) = 168, 500, 1000 hrs	–
Latch-up	TA=25°C, VCC = Max. operating voltage, 150mA/20V	–
ESD (HBM)	TA=25°C, ≥   ± 3KV	IP_ND,OP_ND,IO_ND IP_NS,OP_NS,IO_NS IP_PD,OP_PD,IO_PD,
ESD (MM)	TA=25°C, ≥   ± 300V	IP_PS,OP_PS,IO_PS, VDD-VSS(+),VDD_VSS (-) mode

### E.1 Address Trap Detect

An address trap detect is one of the MCU embedded fail-safe functions that detects MCU malfunction caused by noise or the like. Whenever the MCU attempts to fetch an instruction from a certain section of ROM, an internal recovery circuit is auto started. If a noise-caused address error is detected, the MCU will repeat execution of the program until the noise is eliminated. The MCU will then continue to execute the next program.