EM78P163N

**8-Bit Microcontroller
with OTP ROM**

**Product
Specification**

DOC. VERSION 1.8

ELAN MICROELECTRONICS CORP.

February 2013



Trademark Acknowledgments:

IBM is a registered trademark and PS/2 is a trademark of IBM.

Windows is a trademark of Microsoft Corporation.

ELAN and ELAN logo  are trademarks of ELAN Microelectronics Corporation.

Copyright © 2008~2013 by **ELAN Microelectronics Corporation**

All Rights Reserved

Printed in Taiwan

The contents of this specification are subject to change without further notice. ELAN Microelectronics assumes no responsibility concerning the accuracy, adequacy, or completeness of this specification. ELAN Microelectronics makes no commitment to update, or to keep current the information and material contained in this specification. Such information and material may change to conform to each confirmed order.

In no event shall ELAN Microelectronics be made responsible for any claims attributed to errors, omissions, or other inaccuracies in the information or material contained in this specification. ELAN Microelectronics shall not be liable for direct, indirect, special incidental, or consequential damages arising from the use of such information or material.

The software (if any) described in this specification is furnished under a license or nondisclosure agreement, and may be used or copied only in accordance with the terms of such agreement.

ELAN Microelectronics products are not intended for use in life support appliances, devices, or systems. Use of ELAN Microelectronics product in such applications is not supported and is prohibited.

NO PART OF THIS SPECIFICATION MAY BE REPRODUCED OR TRANSMITTED IN ANY FORM OR BY ANY MEANS WITHOUT THE EXPRESSED WRITTEN PERMISSION OF ELAN MICROELECTRONICS.



ELAN MICROELECTRONICS CORPORATION

Headquarters:

No. 12, Innovation 1st Road
Hsinchu Science Park
Hsinchu, TAIWAN 30076
Tel: +886 3 563-9977
Fax: +886 3 563-9966
webmaster@emc.com.tw
<http://www.emc.com.tw>

Hong Kong:

Elan (HK) Microelectronics Corporation, Ltd.
Flat A, 19F., World Tech Centre
95 How Ming Street, Kwun Tong
Kowloon, HONG KONG
Tel: +852 2723-3376
Fax: +852 2723-7780

USA:

Elan Information Technology Group (U.S.A.)
PO Box 601
Cupertino, CA 95015
U.S.A.
Tel: +1 408 366-8225
Fax: +1 408 366-8225

Korea:**Elan Korea Electronics Company, Ltd.**

301 Dong-A Building
632 Kojan-Dong, Namdong-ku
Incheon City, KOREA
Tel: +82 32 814-7730
Fax: +82 32 813-7730

Shenzhen:**Elan Microelectronics Shenzhen, Ltd.**

8A Floor, Microprofit Building
Gaoxin South Road 6
Shenzhen Hi-tech Industrial Park
South Area, Shenzhen
CHINA 518057
Tel: +86 755 2601-0565
Fax: +86 755 2601-0500
elan-sz@elanic.com.cn

Shanghai:**Elan Microelectronics Shanghai, Ltd.**

6F, Ke Yuan Building
No. 5 Bibo Road
Zhangjiang Hi-Tech Park
Shanghai, CHINA 201203
Tel: +86 21 5080-3866
Fax: +86 21 5080-0273
elan-sh@elanic.com.cn

Contents

1	General Description	1
2	Features	1
3	Pin Assignment	2
4	Pin Description	3
5	Functional Description	4
5.1	Operational Registers.....	5
5.1.1	R0 (Indirect Addressing Register)	5
5.1.2	R1 (Timer Clock/Counter)	5
5.1.3	R2 (Program Counter) and Stack	5
5.1.4	R3 (Status Register).....	7
5.1.5	R4 (RAM Select Register).....	7
5.1.6	R5 (Port 5).....	7
5.1.7	R6 (Port 6).....	8
5.1.8	R7 (TBLP : Table Point Register)	8
5.1.9	R8 (TBHP : Table Point Register)	8
5.1.10	R9 (Unused).....	8
5.1.11	RA (PWMCON: PWM Control Register)	8
5.1.12	RB (CMPCON I : Comparator Control Register I)	9
5.1.13	RC (CMPCON II: Comparator Control Register II)	10
5.1.14	RD (System Control Register).....	11
5.1.15	RE (WUCR: Wake-up Control Register)	12
5.1.16	RF (Interrupt Status Register)	12
5.1.17	R10 ~ R3F	13
5.2	Special Purpose Registers	13
5.2.1	A (Accumulator).....	13
5.2.2	CONT (Control Register).....	13
5.2.3	IOC5 (I/O Port Control Register)	14
5.2.4	IOC6 (I/O Port Control Register)	14
5.2.5	IOC7 (TMRH: Most Significant Bits of the PWM Timer).....	14
5.2.6	IOC8 (TMRL: Least Significant Byte of the PWM Timer).....	15
5.2.7	IOC9 (PRDL: Least Significant Byte of the PWM Time Period).....	15
5.2.8	IOCA (DTL: Least Significant Byte of the PWM Duty Cycle)	15
5.2.9	IOCB (Pull-down Control Register)	15
5.2.10	IOCC (Open-drain Control Register).....	16
5.2.11	IOCD (Pull-high Control Register).....	16
5.2.12	IOCE (WDT Control Register).....	17
5.2.13	IOCF (Interrupt Mask Register).....	18

5.3	TCC/WDT and Prescaler.....	19
5.4	I/O Ports	20
5.5	Reset and Wake-up.....	23
5.5.1	Reset	23
5.5.2	Wake-up and Interrupt Modes Operation Summary	25
5.5.3	/RESET Configure.....	31
5.5.4	Status of RST, T, and P of the Status Register.....	31
5.6	Interrupt	32
5.7	PWM (Pulse Width Modulation)	34
5.7.1	Overview	34
5.7.2	Increment Timer Counter (TMRX: TMRH/TMRL).....	35
5.7.3	PWM Time Period (PRDX: TMRH/PRDL).....	35
5.7.4	PWM Duty Cycle (DTX: TMRH/DTL)	36
5.7.5	Comparator	36
5.7.6	PWM Programming Process/Steps.....	36
5.8	Timer	36
5.8.1	Overview	36
5.8.2	Function Description.....	37
5.8.3	Programming the Related Registers	37
5.8.3.1	TMR Related Control Registers.....	37
5.8.4	Timer Programming Process/Steps.....	37
5.9	Comparator	38
5.9.1	External Reference Signal	38
5.9.2	Comparator Outputs.....	39
5.9.3	Comparator Interrupt.....	39
5.9.4	Wake-up from Sleep Mode.....	40
5.10	Oscillator	40
5.10.1	Oscillator Modes.....	40
5.10.2	Crystal Oscillator/Ceramic Resonator (Crystal)	41
5.10.3	External RC Oscillator Mode.....	42
5.10.4	Internal RC Oscillator Mode	43
5.11	Power-on Considerations	45
5.11.1	External Power-on Reset Circuit.....	45
5.11.2	Residual Voltage Protection	46
5.12	Code Option Register.....	46
5.12.1	Code Option Register (Word 0).....	47
5.12.2	Code Option Register (Word 1).....	48
5.12.3	Customer ID Register (Word 2).....	49
5.13	Instruction Set	50

6	Absolute Maximum Ratings	53
7	Electrical Characteristics	53
7.1	DC Electrical Characteristic.....	53
7.2	Comparator Characteristics.....	55
7.3	AC Electrical Characteristics	56
7.4	Device Characteristics.....	56
8	Timing Diagram	68

APPENDIX

A	Package Type.....	69
B	Package Information	70
C	Quality Assurance and Reliability	74
C.1	Address Trap Detect.....	74

Specification Revision History

Doc. Version	Revision Description	Date
1.0	Initial version	2008/07/09
1.1	Modified some descriptions of the code option	2008/08/11
1.2	Added description of RC Bit 7	2008/12/09
1.3	Modified the DC Electrical Characteristics	2009/03/24
1.4	Modified the operation voltage range	2009/08/10
1.5	Added P51~P54 IOH DC electrical characteristics	2010/01/29
1.6	Modified some description error Modified the pin description format Added device characteristics	2010/02/10
1.7	Modified the package name from EM78P163NSO16J to EM78P163NSO16AJ	2010/11/02
1.8	1. Added Ordering and Manufacturing Information. 2. Added LVR specification	2013/02/27



1 General Description

The EM78P163N is an 8-bit microprocessor designed and developed with low-power and high-speed CMOS technology. It has an on-chip 1K×13-bit Electrical One Time Programmable Read Only Memory (OTP-ROM). It provides three protection bits to prevent intrusion of user's OTP memory code as well as from unwanted external accesses. Several code option bits are available to meet user's requirements.

With its enhanced OTP-ROM feature, the EM78P163N provides a convenient way of developing and verifying user's programs. Moreover, this OTP device offers the advantages of easy and effective program updates, using development and programming tools. User can avail of the ELAN Writer to easily program his development code.

2 Features

- CPU Configuration
 - 1K×13 bits on-chip ROM
 - 48×8 bits on-chip registers (SRAM, general purpose)
 - 5-level stacks for subroutine nesting
 - Less than 1.5mA at 5V/IRC 4 MHz
 - Typically 15 μ A, at 3V/32kHz
 - Typically 1 μ A, during Sleep mode
 - 3 programmable Level Voltage Reset (LVR): 4.0V, 3.3V 2.4V
 - Power-on Reset (POR): 1.8V
- I/O Port Configuration
 - 2 bidirectional I/O ports : P5, P6
 - Wake-up port : P6
 - 7 programmable pull-down I/O pins
 - 7 programmable pull-high I/O pins
 - 7 programmable open-drain I/O pins
 - External interrupt : P60
- Operating Voltage Range:
 - Operating voltage: 2.1V~5.5V at 0°C ~70°C (commercial)
 - Operating voltage: 2.3V~5.5V at -40°C ~85°C (industrial)
- Operating Frequency range (base on 2 clocks):
 - Crystal Mode:
 - DC~20MHz/2clks @ 5V
 - DC~8MHz/2clks @ 3V
 - DC~4MHz/2clks @ 2.1V
 - ERC Mode:
 - DC~16 MHz/2clks @ 4.5V
 - DC~12 MHz/2clks @ 4V
 - DC~4MHz/2clks @ 2.1V
 - Internal RC Drift Rate:
(Ta=25°C, VDD=5V \pm 5%, VSS=0V)

Internal RC Frequency	Drift Rate			
	Temperature (-40C~85C)	Voltage (2.0V~5.5V)	Process	Total
455kHz	\pm 5%	\pm 5%	\pm 3%	\pm 13%
4 MHz	\pm 5%	\pm 5%	\pm 3%	\pm 13%
8 MHz	\pm 5%	\pm 5%	\pm 3%	\pm 13%
16 MHz	\pm 6%	\pm 5%	\pm 3%	\pm 14%

- Peripheral Configuration
 - 8-bit real time clock/counter (TCC) with selective signal sources, trigger edges, and overflow interrupt
 - One comparator (typical offset voltage 10 mV when input voltage range 0.5V~4.5V) with Cin+/internal Vref level select and Cin- 4 channel switch.
 - One Pulse Width Modulation (PWM) with 10-bit resolution
 - High EFT immunity
 - Power down mode (Sleep mode)
- Five available Interrupts:
 - TCC overflow interrupt
 - Input-port status changed interrupt (wake-up from sleep mode)
 - External interrupt
 - PWM period match completion
 - Comparator output change interrupt
- Other Features
 - Programmable prescaler of oscillator set-up time
 - One security register to prevent intrusion of user's OTP memory code
 - One configuration register to match user's requirements
 - Two clocks per instruction cycle
 - TBRD instruction
- Package Type:
 - 14-pin DIP 300mil : EM78P163ND14J
 - 14-pin SOP 150mil : EM78P163NSO14J
 - 16-pin DIP 300mil : EM78P163ND16J
 - 16-pin SOP 150mil : EM78P163NSO16AJ

Note: These are Green products that do not contain hazardous substances.

3 Pin Assignment

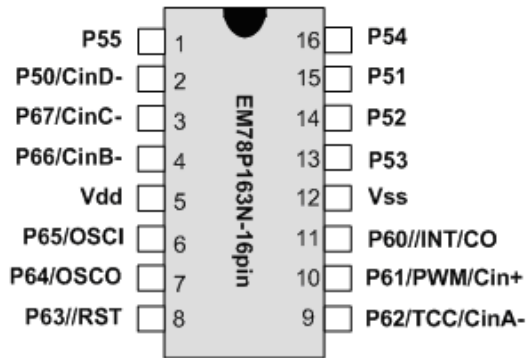

Figure 3-1 EM78P163ND16/SO16

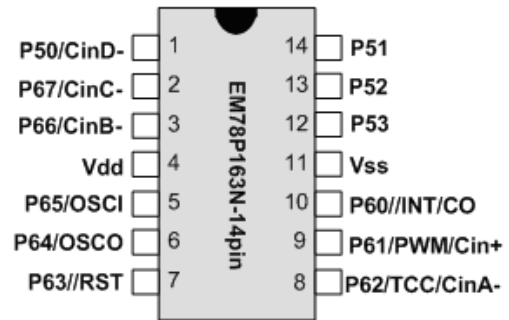

Figure 3-2 EM78P163ND14/SO14

4 Pin Description

Name	Function	Input Type	Output Type	Description
VDD	VDD	Power	-	Power
VSS	VSS	Power		Ground
P50/CinD-	P50	ST	CMOS	Bidirectional I/O pin with programmable pull-down
	CinD-	AN		Inverting end D of comparator
P51	P51	ST	CMOS	Bidirectional I/O pin with programmable pull-down
P52	P52	ST	CMOS	Bidirectional I/O pin with programmable pull-down
P53	P53	ST	CMOS	Bidirectional I/O pin with programmable pull-down
P54	P54	ST	CMOS	Bidirectional I/O pin
P55	P55	ST	CMOS	Bidirectional I/O pin
P60//INT/CO	P60	ST	CMOS	Bidirectional I/O pin with programmable pull-down, pull-high, open-drain, and pin change wakeup
	/INT	ST	-	external interrupt pin
	CO	-	CMOS	Output of comparator
P61/PWM/Cin+	P61	ST	CMOS	Bidirectional I/O pin with programmable pull-down, pull-high, open-drain, and pin change wakeup
	PWM	-	-	PWM output
	Cin+	AN	-	Non-inverting end of comparator
P62/TCC/CinA-	P62	ST	CMOS	Bidirectional I/O pin with programmable pull-down, pull-high, open-drain, and pin change wakeup
	TCC	ST	-	TCC clock input
	CinA-	AN	-	Inverting end of comparator
P63//RST	P63	ST	CMOS	Bidirectional I/O pin
	/RST	ST	-	Internal pull-high reset pin
P64/OSCO	P64	ST	CMOS	Bidirectional I/O pin with programmable pull-high, open-drain, and pin change wakeup
	OSCO	-	XTAL	Clock output of crystal/ resonator oscillator
P65/OSCI	P65	ST	CMOS	Bidirectional I/O pin with programmable pull-high, open-drain, and pin change wakeup
	OSCI	XTAL	-	Clock input of crystal/ resonator oscillator
P66/CinB-	P66	ST	CMOS	Bidirectional I/O pin with programmable pull-high, open-drain, and pin change wakeup
	CinB-	AN	-	Inverting end of comparator
P67/CinC-	P67	ST	CMOS	Bidirectional I/O pin with programmable pull-high, open-drain, and pin change wakeup
	CinC-	AN	-	Inverting end of comparator

5 Functional Description

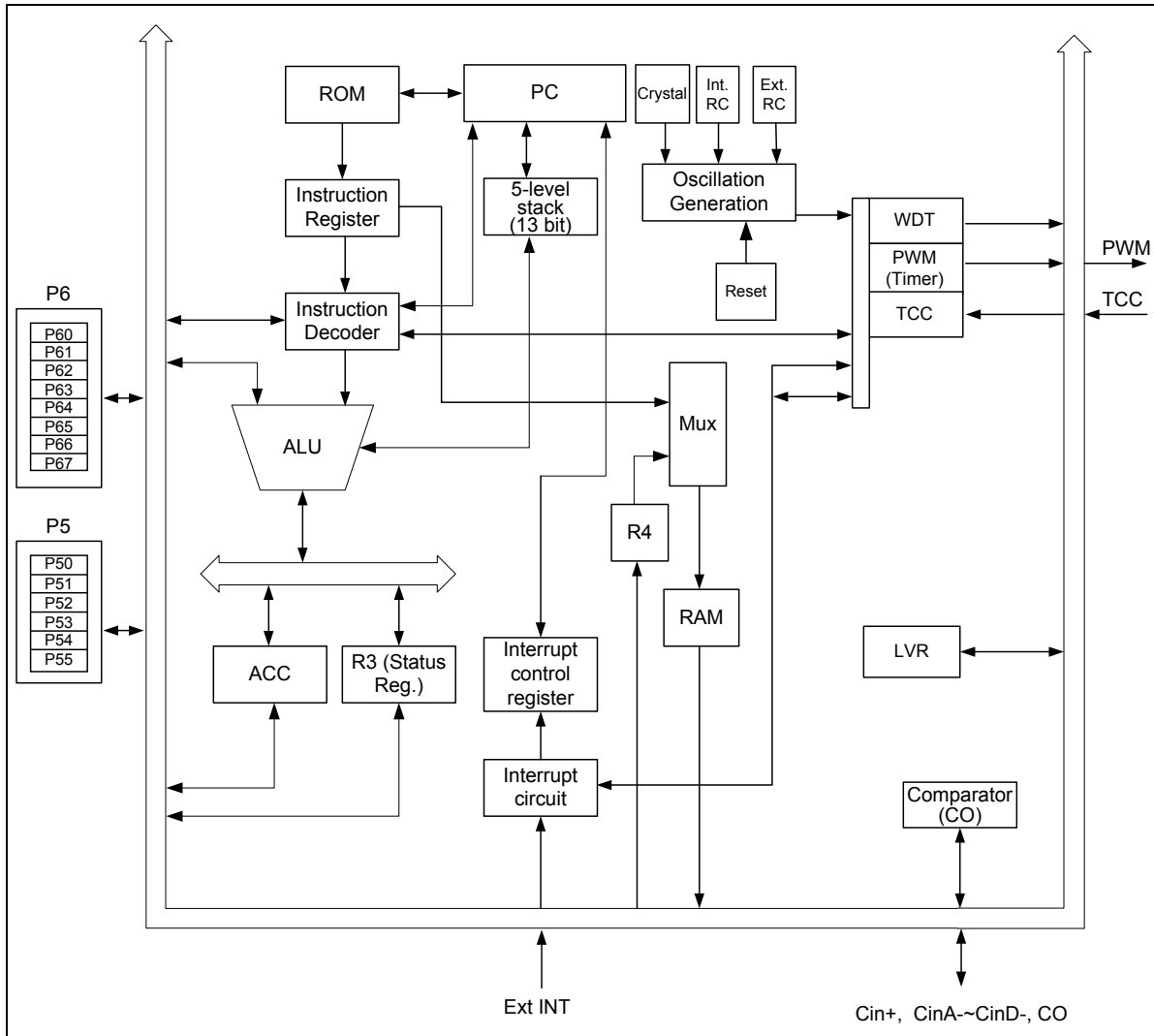

Figure 5-1 Functional Block Diagram

5.1 Operational Registers

5.1.1 R0 (Indirect Addressing Register)

R0 is not a physically implemented register. It is used as an indirect addressing pointer. Any instruction using R0 as a pointer actually accesses data pointed by the RAM Select Register (R4).

5.1.2 R1 (Timer Clock/Counter)

- Incremented by an external signal edge, through the TCC pin, or by the instruction cycle clock.
- External signal of TCC trigger pulse width must be greater than one instruction.
- The signals to increase the counter are determined by Bit 4 and Bit 5 of the CONT register.
- Writable and readable as any other registers.

5.1.3 R2 (Program Counter) and Stack

- Depending on the device type, R2 and hardware stack are 10-bit wide. The structure is depicted in the following figure.

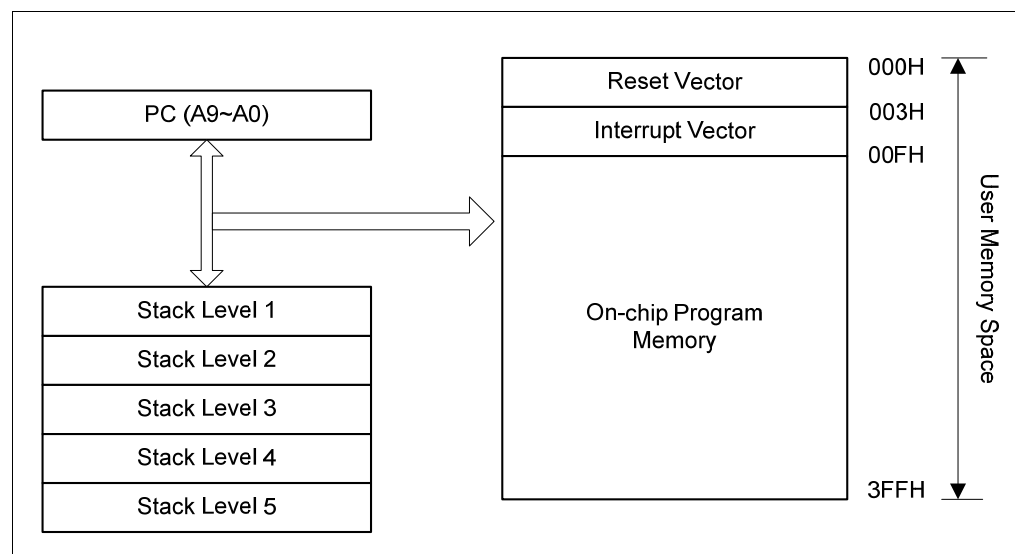

Figure 5-2 Program Counter Organization

- The configuration structure generates 1K×13 bits on-chip OTP ROM addresses to the relative programming instruction codes. One program page is 1024 words long.
- R2 is set as all "0" when under Reset condition.
- "JMP" instruction allows direct loading of the lower 10 program counter bits. Thus, "JMP" allows the PC to go to any location within a page.



- "CALL" instruction loads the lower 10 bits of the PC, and then PC+1 is pushed onto the stack. Thus, the subroutine entry address can be located anywhere within a page.
- "RET" ("RETL k", "RETI") instruction loads the program counter with the contents of the top-level stack.
- "ADD R2,A" allows the contents of 'A' to be added to the current PC, and the ninth and tenth bits of the PC will increase progressively.
- "MOV R2, A" allows loading of an address from the "A" register to the lower 8 bits of the PC, and the ninth and tenth bits of the PC will remain unchanged.
- Any instruction except "ADD R2,A" written to R2 (e.g. "MOV R2, A", "BC R2, 6", etc.) will cause the ninth bit and the tenth bit (A8 ~ A9) of the PC to remain unchanged.
- All instructions are single instruction cycle (fclk/2 or fclk/4) except for instructions that would change the contents of R2. Such instructions will need one more instruction cycle.
- The Data Memory Configuration is as follows:

Address	R PAGE Registers	IOC PAGE Registers
00	R0	
01	R1 (TCC)	CONT (Control Register)
02	R2 (PC)	
03	R3 (Status)	
04	R4 (RSR)	
05	R5 (Port 5)	IOC5 (I/O Port Control Register)
06	R6 (Port 6)	IOC6 (I/O Port Control Register)
07	R7 (TBLP: Table Pointer Register)	IOC7 (TMRH: PWM timer)
08	R8 (TBHP: Table Pointer Register)	IOC8 (TIMEL: PWM timer)
09	R9 (Option Control bits)	IOC9 (PRDL: PWM period)
0A	RA (PWM Control Register)	IOCA (DTL: Duty cycle of PWM)
0B	RB (Comparator Control Register I)	IOCB (Pull-down Register)
0C	RC (Comparator Control Register II)	IOCC (Open-drain Register)
0D	RD (System Control Register)	IOCD (Pull-high Register)
0E	RE (Wake-up Control Register)	IOCE (WDT Control Register)
0F	RF (Interrupt Status Register)	IOCF (Interrupt Mask Register)
10 : 3F	General Registers	

5.1.4 R3 (Status Register)

Bit 7	Bit 6	Bit 5	Bit 4	Bit 3	Bit 2	Bit 1	Bit 0
RST	GP1	GP0	T	P	Z	DC	C

Bit 7 (RST): Bit for reset type (read only)

0 : Set to 0 if the device wakes up from other reset type

1 : Set to 1 if the device wakes up from sleep mode on a pin change

Bits 6 ~ 5 (GP1 ~ GP0): General purpose read/write bits.

Bit 4 (T): Time-out bit

Set to 1 with the "SLEP" and "WDTC" command, or during power up and reset to 0 by WDT time-out.

Bit 3 (P): Power down bit

Set to 1 during power-on or by a "WDTC" command and reset to 0 by a "SLEP" command.

NOTE

Bit 4 and Bit 3 (T and P) are read only.

Bit 2 (Z): Zero flag.

Set to "1" if the result of an arithmetic or logic operation is zero.

Bit 1 (DC): Auxiliary carry flag

Bit 0 (C): Carry flag

5.1.5 R4 (RAM Select Register)

Bits 7 ~ 6 are general-purpose read/write bits. See the *Data Memory Configuration*.

Bits 5 ~ 0 are used to select registers (Address: 10~3F) in the indirect addressing mode.

5.1.6 R5 (Port 5)

Bit 7	Bit 6	Bit 5	Bit 4	Bit 3	Bit 2	Bit 1	Bit 0
0	0	P55	P54	P53	P52	P51	P50

Bits 7 ~ 6 (Unused): Unused bits. Set to 0 all the time.

Bits 5 ~ 0 (P55 ~ P50): I/O data registers. User can use the IOC5 to define each bit as input/output

5.1.7 R6 (Port 6)

Bit 7	Bit 6	Bit 5	Bit 4	Bit 3	Bit 2	Bit 1	Bit 0
P67	P66	P65	P64	P63	P62	P61	P60

Bits 7 ~ 0 (P67 ~ P60): I/O data registers. User can use the IOC6 to define each bit as input/output.

5.1.8 R7 (TBLP : Table Point Register)

Bit 7	Bit 6	Bit 5	Bit 4	Bit 3	Bit 2	Bit 1	Bit 0
TBA7	TBA6	TBA5	TBA4	TBA3	TBA2	TBA1	TBA0

Bits 7 ~ 0 (TBA7 ~ TBA0): Table Point Address Bits 7~0.

5.1.9 R8 (TBHP : Table Point Register)

Bit 7	Bit 6	Bit 5	Bit 4	Bit 3	Bit 2	Bit 1	Bit 0
HLB	0	0	0	0	0	TBA9	TBA8

Bit 7 (HLB): Take MSB or LSB of machine code.

0: LSB of machine code.

1: MSB of machine code.

Bits 6 ~ 2 (Unused): Unused bits. Set to 0 all the time.

Bits 1 ~ 0 (TBA9 ~ TBA8): Table Point Address Bits 9 ~ 8.

5.1.10 R9 (Unused)

5.1.11 RA (PWMCON: PWM Control Register)

Bit 7	Bit 6	Bit 5	Bit 4	Bit 3	Bit 2	Bit 1	Bit 0
0	0	0	PWME	TEN	TP2	TP1	TP0

Bits 7 ~ 5 (Unused): Unused bits. Set to 0 all the time.

Bit 4 (PWME): PWM enable bit

0 : PWM is off (default value), and its related pin carries out the P61 function.

1 : PWM is on, and its related pin is automatically set to output.

NOTE

The P61/PWM/Cin+ pin priority is as follows:

P61/CO/PWM Priority		
High	Medium	Low
Cin+	PWM	P61

Bit 3 (TEN): TMR enable bit
0 : TMR is off (default value)
1 : TMR is on

Bits 2 ~ 0 (TP2 ~ TP0): TMR clock prescaler bits

TP2	TP1	TP0	Prescale
0	0	0	1:1 (default)
0	0	1	1:2
0	1	0	1:4
0	1	1	1:8
1	0	0	1:16
1	0	1	1:64
1	1	0	1:128
1	1	1	1:256

5.1.12 RB (CMPCON I : Comparator Control Register I)

Bit 7	Bit 6	Bit 5	Bit 4	Bit 3	Bit 2	Bit 1	Bit 0
ACOS1	ACOS0	BCOS1	BCOS0	CCOS1	CCOS0	DCOS1	DCOS0

Bits 7 ~ 0 (XCOS1 ~ XCOS0): Comparator Select bits

XCOS1	XCOS0	Function Description
0	0	Comparator is not used. P50, P60, P61, P62, P66, and P67 functions as normal I/O pins.
1	1	
0	1	Used as Comparator and P60 functions as normal I/O pin *1
1	0	Used as Comparator and P60 functions as Comparator output pin (CO) *1

*1: For Cin+ and Cin- definition, refer to RC control register.

NOTE

The P60//INT/CO pin priority is as follows:

P61/PWM/Cin+ Priority		
High	Medium	Low
CO	/INT	P60

5.1.13 RC (CMPCON II: Comparator Control Register II)

Bit 7	Bit 6	Bit 5	Bit 4	Bit 3	Bit 2	Bit 1	Bit 0
CRS	CIRL2	CIRL1	CIRL0	CPOUT	COE	CRCS1	CRCS0

Bit 7 (CRS): Comparator reference voltage source select bit. When the comparator is disabled, this bit must also be set to 0.

0 : Disable internal voltage reference, CIN+ source external (default value). If the comparator is disabled, P61/PWM/CIN+ pin activates as I/O.

1 : Enable internal voltage reference. P61/PWM/CIN+ pin activates as I/O.

Bits 6 ~ 4 (CIRL2 ~ CIRL0): Comparator internal reference level

CIRL2	CIRL1	CIRL0	Voltage Level (V)
0	0	0	0.1VDD
0	0	1	0.15VDD
0	1	0	0.2VDD
0	1	1	0.3VDD
1	0	0	0.4VDD
1	0	1	0.45VDD
1	1	0	0.5VDD
1	1	1	0.6VDD

Bit 3 (CPOUT): Result of the comparator output.

Bit 2 (COE): Comparator enable bit (RB effect when this bit = 1)

0 : Comparator function is disabled (default value)

1 : Comparator function is enabled

Bits 1 ~ 0 (CRCS1 ~ CRCS0): Comparator CIN- channel switch

CRCS1	CRCS0	Prescale
0	0	P62/TCC/CinA- is set as CinA- pin (default)
0	1	P66/CinB- is set as CinB- pin
1	0	P67/CinC- is set as CinC- pin
1	1	P50/CinD- is set as CinD- pin

NOTE

The P62/TCC/CinA- Pin Priority is as follows:

P62/TCC/CinA- Priority		
High	Medium	Low
CinA-	TCC	P62

5.1.14 RD (System Control Register)

Bit 7	Bit 6	Bit 5	Bit 4	Bit 3	Bit 2	Bit 1	Bit 0
TIMERSC	CPUS	IDLE	0	0	0	0	0

Bit 7 (TIMERSC): TCC, TMR clock source select

0 : Fs, sub frequency for WDT internal RC time base

1 : Fm, main-oscillator clock

Bit 6 (CPUS): CPU Oscillator Source Select

0 : sub-oscillator (fs)

1 : main oscillator (fosc)

When CPUS=0, the CPU oscillator selects sub-oscillator and the main oscillator is stopped.

Bit 5 (IDLE): Idle mode enable bit.

0 : IDLE="0"+SLEP instruction → sleep mode

1 : IDLE="1"+SLEP instruction → idle mode

■ CPU Operation Mode

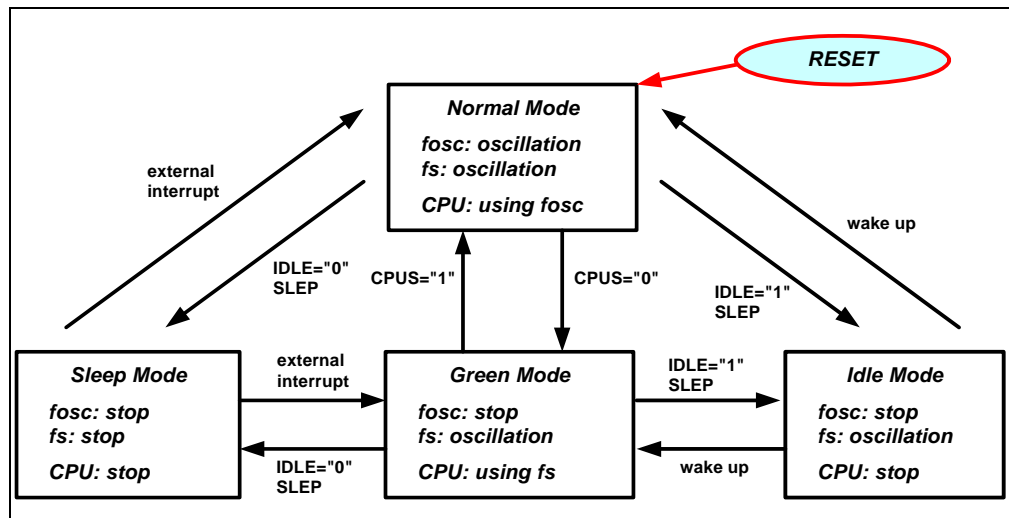

Figure 5-3 CPU Operation Mode

Bits 4 ~ 0 (Unused): Unused bits, set to 0 all the time.

5.1.15 RE (WUCR: Wake-up Control Register)

Bit 7	Bit 6	Bit 5	Bit 4	Bit 3	Bit 2	Bit 1	Bit 0
0	0	0	0	0	CMPWE	ICWE	0

Bits 7 ~ 3 (Unused): Unused bits. Set to 0 all the time.

Bit 2 (CMPWE): Comparator wake-up enable bit
0 : Disable Comparator wake up
1 : Enable Comparator wake up

When the Comparator output status change is used to enter an interrupt vector or to wake-up the EM78P163N from sleep mode, the CMPWE bit must be set to "Enable".

Bit 1 (ICWE): Port 6 input change to wake-up status enable bit
0 : Disable Port 6 input change to wake-up status
1 : Enable Port 6 input change wake-up status

When the Port 6 Input Status Change is used to enter an interrupt vector or to wake-up the EM78P163N from sleep mode, the ICWE bit must be set to "Enable".

Bit 0 (Unused): Unused bit, set to 0 all the time

5.1.16 RF (Interrupt Status Register)

Bit 7	Bit 6	Bit 5	Bit 4	Bit 3	Bit 2	Bit 1	Bit 0
0	0	0	PWMIF	CMPIF	EXIF	ICIF	TCIF

"1" means there is an interrupt request "0" means no interrupt occurs.

Bits 7 ~ 5 (unused): Unused bits. Set to 0 all the time.

Bit 4 (PWMIF): PWM (Pulse Width Modulation) interrupt flag. Set when a selected duration is reached. Reset by software.

Bit 3 (CMPIF): Comparator Interrupt flag. Set when a change occurs in the Comparator output. Reset by software.

Bit 2 (EXIF): External interrupt flag. Set by falling edge on /INT pin, reset by software.

Bit 1 (ICIF): Port 6 input status changed interrupt flag. Set when Port 6 input changes, reset by software.

Bit 0 (TCIF): TCC overflow interrupt flag. Set when TCC overflows, reset by software.

- RF can be cleared by instruction but cannot be set.
- IOCF is the interrupt mask register.
- Note that the result of reading RF is the "logic AND" of RF and IOCF.

5.1.17 R10 ~ R3F

- All of these are 8-bit general-purpose registers.

5.2 Special Purpose Registers

5.2.1 A (Accumulator)

Internal data transfer operation, or instruction operand holding usually involves the temporary storage function of the Accumulator, which is not an addressable register.

5.2.2 CONT (Control Register)

Bit 7	Bit 6	Bit 5	Bit 4	Bit 3	Bit 2	Bit 1	Bit 0
INTE	INT	TS	TE	PSTE	PST2	PST1	PST0

Bit 7 (INTE): INT signal edge

- 0 : interrupt occurs at a rising edge of the INT pin
- 1 : interrupt occurs at a falling edge of the INT pin

Bit 6 (INT): Interrupt enable flag

- 0 : masked by DISI or hardware interrupt
- 1 : enabled by ENI/RETI instructions

Bit 5 (TS): TCC signal source

- 0 : internal instruction cycle clock, P62 is a bidirectional I/O pin.
- 1 : transition on the TCC pin

NOTE

The P62/TCC/CinA- Pin Priority is as follows:

P62/TCC/CinA- Priority		
High	Medium	Low
CinA-	TCC	P62

Bit 4 (TE): TCC signal edge

- 0 : increment if a transition from low to high takes place on the TCC pin.
- 1 : increment if a transition from high to low takes place on the TCC pin.

Bit 3 (PSTE): Prescaler enable bit for TCC

- 0 : prescaler disable bit. TCC rate is 1:1.
- 1 : prescaler enable bit. TCC rate is set at Bit 2 ~ Bit 0.

Bits 2 ~ 0 (PST2 ~ PST0): TCC prescaler bits

PST2	PST1	PST0	TCC Rate
0	0	0	1:2
0	0	1	1:4
0	1	0	1:8
0	1	1	1:16
1	0	0	1:32
1	0	1	1:64
1	1	0	1:128
1	1	1	1:256

5.2.3 IOC5 (I/O Port Control Register)

Bit 7	Bit 6	Bit 5	Bit 4	Bit 3	Bit 2	Bit 1	Bit 0
-	-	IOC55	IOC54	IOC53	IOC52	IOC51	IOC50

Bits 7 ~ 6 (Unused): unused bits

Bits 5 ~ 0 (IOC55 ~ IOC50): I/O direction control register

0 : defines the relative I/O pin as output

1 : puts the relative I/O pin into high impedance

5.2.4 IOC6 (I/O Port Control Register)

Bit 7	Bit 6	Bit 5	Bit 4	Bit 3	Bit 2	Bit 1	Bit 0
IOC67	IOC66	IOC65	IOC64	IOC63	IOC62	IOC61	IOC60

Bits 7~0 (IOC67 ~ IOC60): I/O direction control register

0 : defines the relative I/O pin as output

1 : puts the relative I/O pin into high impedance

5.2.5 IOC7 (TMRH: Most Significant Bits of the PWM Timer)

Bit 7	Bit 6	Bit 5	Bit 4	Bit 3	Bit 2	Bit 1	Bit 0
0	0	TMR[9]	TMR[8]	PRD[9]	PRD[8]	DT[9]	DT[8]

Bits 7 ~ 6 (unused): unused bits. Set to 0 all the time.

Bits 5 ~ 4 (TMR[9]~TMR[8]): Most significant bits of the PWM timer, read-only bit.

Bits 3 ~ 2 (PRD[9]~PRD[8]): Most significant bits of the PWM time period.

Bits 1 ~ 0 (DT[9]~DT[8]): Most significant bits of the PWM duty cycle.

5.2.6 IOC8 (TMRL: Least Significant Byte of the PWM Timer)

Bit 7	Bit 6	Bit 5	Bit 4	Bit 3	Bit 2	Bit 1	Bit 0
TMR[7]	TMR[6]	TMR[5]	TMR[4]	TMR[3]	TMR[2]	TMR[1]	TMR[0]

The content of IOC8 is read-only.

5.2.7 IOC9 (PRDL: Least Significant Byte of the PWM Time Period)

Bit 7	Bit 6	Bit 5	Bit 4	Bit 3	Bit 2	Bit 1	Bit 0
PRD[7]	PRD[6]	PRD[5]	PRD[4]	PRD[3]	PRD[2]	PRD[1]	PRD[0]

The content of IOC9 is the time period (time base) of PWM. The PWM frequency is the reverse of the period. Most Significant Bits (Bits 9, 8) of the PWM Period Cycle are located in IOC7<3, 2>.

5.2.8 IOCA (DTL: Least Significant Byte of the PWM Duty Cycle)

Bit 7	Bit 6	Bit 5	Bit 4	Bit 3	Bit 2	Bit 1	Bit 0
DT[7]	DT[6]	DT[5]	DT[4]	DT[3]	DT[2]	DT[1]	DT[0]

A specified value keeps the PWM output to remain high until the value matches with TMR.

5.2.9 IOCB (Pull-down Control Register)

Bit 7	Bit 6	Bit 5	Bit 4	Bit 3	Bit 2	Bit 1	Bit 0
0	/PD62	/PD61	/PD60	/PD53	/PD52	/PD51	/PD50

Bit 7 (Unused): Unused bit, set to 0 all the time

Bit 6 (/PD62): Control bit used to enable pull-down of P62 pin.

0 : Enable internal pull-down

1 : Disable internal pull-down

Bit 5 (/PD61): Control bit used to enable pull-down of the P61 pin.

Bit 4 (/PD60): Control bit used to enable pull-down of the P60 pin.

Bit 3 (/PD53): Control bit used to enable pull-down of the P53 pin.

Bit 2 (/PD52): Control bit used to enable pull-down of the P52 pin.

Bit 1 (/PD51): Control bit used to enable pull-down of the P51 pin.

Bit 0 (/PD50): Control bit used to enable pull-down of the P50 pin.

The IOCB Register is both readable and writable.

5.2.10 IOCC (Open-drain Control Register)

Bit 7	Bit 6	Bit 5	Bit 4	Bit 3	Bit 2	Bit 1	Bit 0
OD67	OD66	OD65	OD64	0	OD62	OD61	OD60

Bit 7 (OD67): Control bit used to enable open-drain of the P67 pin.

0 : Disable open-drain output

1 : Enable open-drain output

Bit 6 (OD66): Control bit used to enable open-drain of the P66 pin.

Bit 5 (OD65): Control bit used to enable open-drain of the P65 pin.

Bit 4 (OD64): Control bit used to enable open-drain of the P64 pin.

Bit 3 (unused): Unused bit. Set to 0 all the time.

Bit 2 (OD62): Control bit used to enable open-drain of the P62 pin.

Bit 1 (OD61): Control bit used to enable open-drain of the P61 pin.

Bit 0 (OD60): Control bit used to enable open-drain of the P60 pin.

The IOCC Register is both readable and writable.

5.2.11 IOCD (Pull-high Control Register)

Bit 7	Bit 6	Bit 5	Bit 4	Bit 3	Bit 2	Bit 1	Bit 0
/PH67	/PH66	/PH65	/PH64	0	/PH62	/PH61	/PH60

Bit 7 (/PH67): Control bit used to enable pull-high of the P67 pin.

0 : Enable internal pull-high

1 : Disable internal pull-high

Bit 6 (/PH66): Control bit used to enable pull-high of the P66 pin.

Bit 5 (/PH65): Control bit used to enable pull-high of the P65 pin.

Bit 4 (/PH64): Control bit used to enable pull-high of the P64 pin.

Bit 3 (unused): Unused bit. Set to 0 all the time.

Bit 2 (/PH62): Control bit used to enable pull-high of the P62 pin.

Bit 1 (/PH61): Control bit used to enable pull-high of the P61 pin.

Bit 0 (/PH60): Control bit used to enable pull-high of the P60 pin.

The IOCD Register is both readable and writable.

5.2.12 IOCE (WDT Control Register)

Bit 7	Bit 6	Bit 5	Bit 4	Bit 3	Bit 2	Bit 1	Bit 0
WDTE	EIS	PSWE	PSW2	PSW1	PSW0	0	0

Bit 7 (WDTE): Control bit used to enable the Watchdog Timer

- 0 : Disable WDT
- 1 : Enable WDT

WDTE is both readable and writable.

Bit 6 (EIS): Control bit used to define the function of the P60 (/INT) pin

- 0 : P60, normal I/O pin
- 1: /INT, external interrupt pin. In this case, the I/O control bit of P60 (Bit 0 of IOC6) must be set to "1"

NOTE

- When EIS is "0," the path of /INT is masked. When EIS is "1," the status of the /INT pin can also be read by way of reading Port 6 (R6). Refer to Figure 6-5 (I/O Port and I/O Control Register Circuit for P60 (/INT)) under Section 6.4 (I/O Ports).
- The EIS is both readable and writable.

Bit 5 (PSWE): prescaler enable bit for WDT

- 0 : prescaler disable bit. WDT rate is 1:1
- 1 : prescaler enable bit. WDT rate is set at Bit 4~Bit 2

Bits 4 ~ 2 (PSW2 ~ PSW0): WDT prescaler bits.

PSW2	PSW1	PSW0	WDT Rate
0	0	0	1:2
0	0	1	1:4
0	1	0	1:8
0	1	1	1:16
1	0	0	1:32
1	0	1	1:64
1	1	0	1:128
1	1	1	1:256

Bits 1 ~ 0: Unused bits. Set to 0 all the time.

5.2.13 IOCF (Interrupt Mask Register)

Bit 7	Bit 6	Bit 5	Bit 4	Bit 3	Bit 2	Bit 1	Bit 0
0	0	0	PWMIE	CMPIE	EXIE	ICIE	TCIE

Bits 7 ~ 5: Unused bits. Set to 0 all the time.

Bit 4 (PWMIE): PWMIF interrupt enable bit

0 : Disable PWM interrupt

1 : Enable PWM interrupt

Bit 3 (CMPIE): CMPIF interrupt enable bit

0 : Disable CMPIF interrupt

1 : Enable CMPIF interrupt

When the Comparator output status change is used to enter an interrupt vector or to enter the next instruction, the CMPIE bit must be set to "Enable".

Bit 2 (EXIE): EXIF interrupt enable bit

0 : disable EXIF interrupt

1 : enable EXIF interrupt

Bit 1 (ICIE): ICIF interrupt enable bit.

0 : Disable ICIF interrupt

1 : Enable ICIF interrupt

Bit 0 (TCIE): TCIF interrupt enable bit.

0 : Disable TCIF interrupt

1 : Enable TCIF interrupt

The IOCF register is both readable and writable.

5.3 TCC/WDT and Prescaler

There are two 8-bit counters available as prescalers for the TCC and WDT respectively. The PST0 ~ PST2 bits of the CONT register are used to determine the ratio of the TCC prescaler, and the PSW0 ~ PSW2 bits of the IOCE0 register are used to determine the WDT prescaler. The prescaler counter is cleared by the instructions each time such instructions are written into the TCC. The WDT and prescaler will be cleared by the “WDTC” and “SLEP” instructions. Figure 5-4 depicts the block diagram of TCC/WDT.

TCC (R1) is an 8-bit timer/counter. The TCC clock source can be an internal clock or external signal input (edge selectable from the TCC pin). If the TCC signal source is from an internal clock, TCC will be incremented by 1 at every 1/Fc clock (without prescaler). If TCC signal source is from the external clock input, TCC will be incremented by 1 at every falling edge or rising edge of the TCC pin. The TCC pin input time length (kept at High or Low level) must be greater than 1CLK.

The watchdog timer is a free running on-chip RC oscillator. The WDT will keep on running even when the oscillator driver has been turned off (i.e., in sleep mode). During normal operation or sleep mode, a WDT time-out (if enabled) will cause the device to reset. The WDT can be enabled or disabled any time during normal mode through software programming. Refer to WDTE bit of the IOCE0 register. Without prescaler, the WDT time-out duration is approximately 18ms.¹

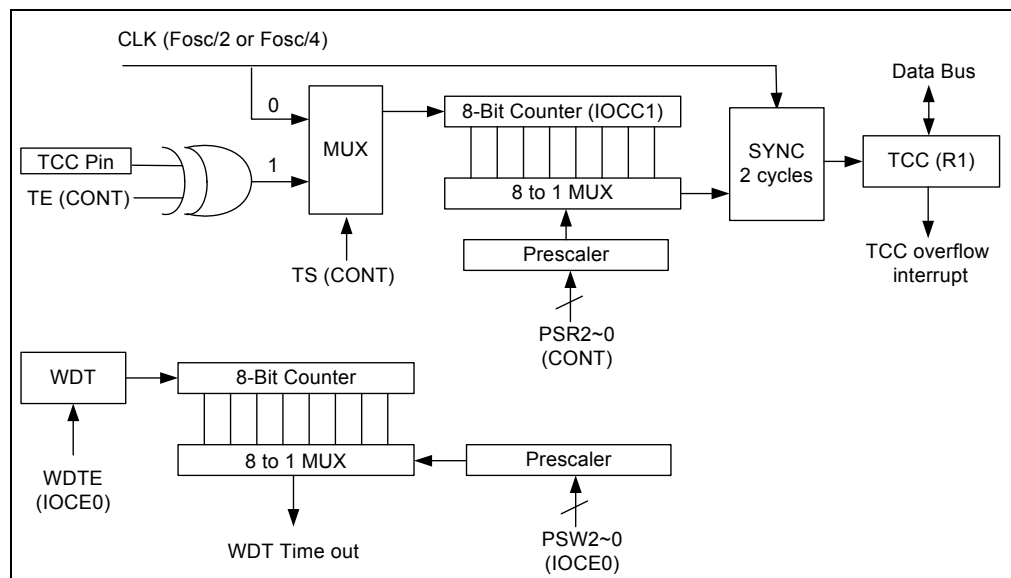
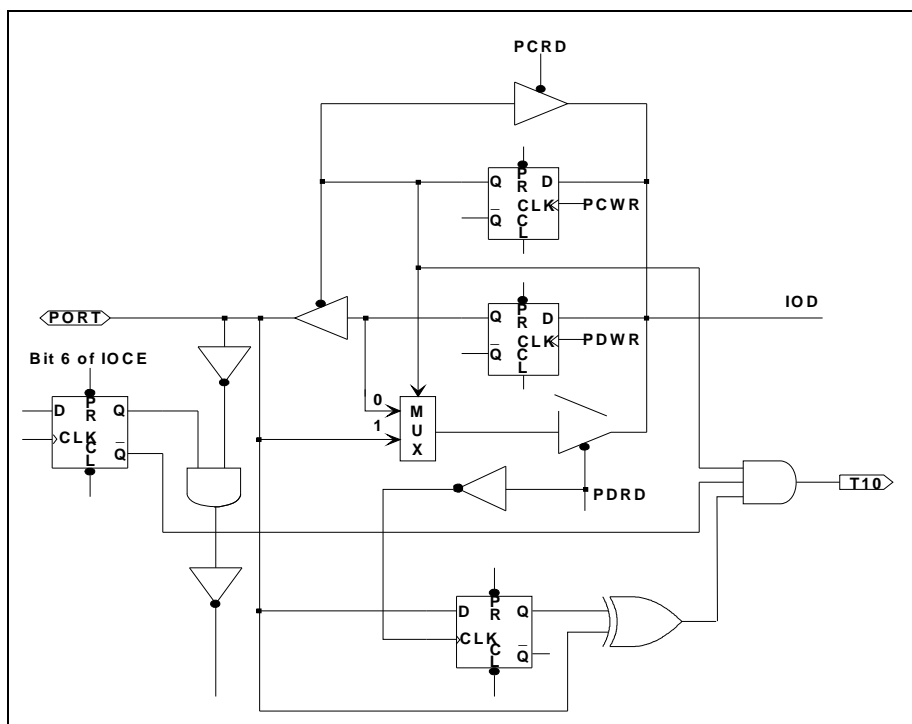

Figure 5-4 TCC and WDT Block Diagram

¹VDD=5V, Setup time period = 16.5ms ± 30%.

VDD=3V, Setup time period = 18ms ± 30%.



Note: Pull-high (down), open-drain is not shown in the figure.

Figure 5-6 Circuit of I/O Port and I/O Control Register for P60 (/INT)

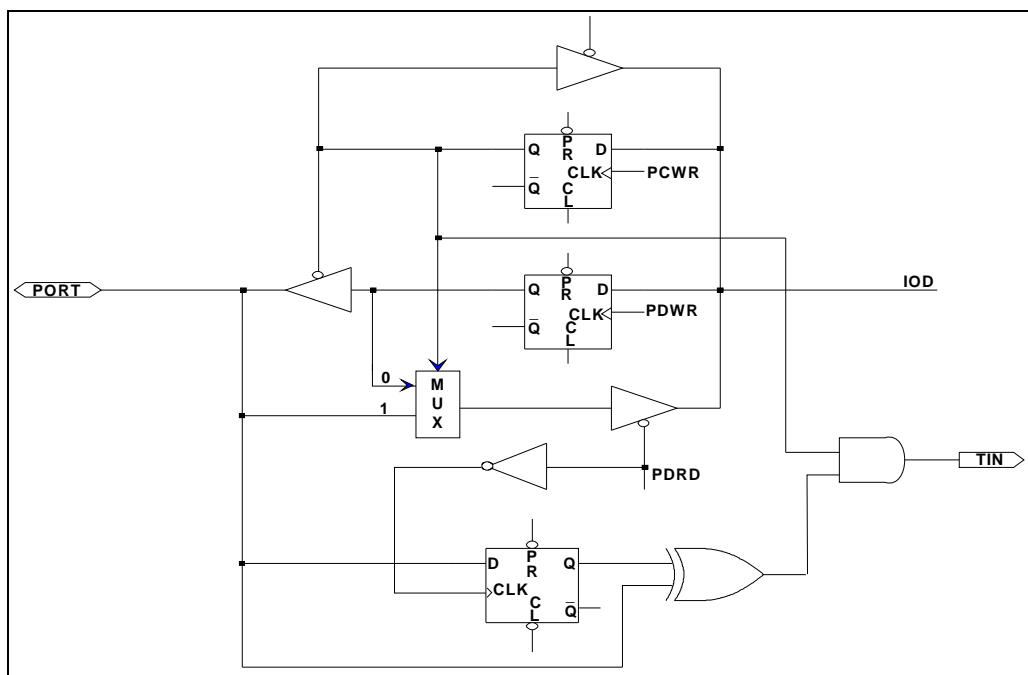

Note: Pull-high (down), open-drain is not shown in the figure.

Figure 5-7 Circuit of I/O Port and I/O Control Register for P61~P67

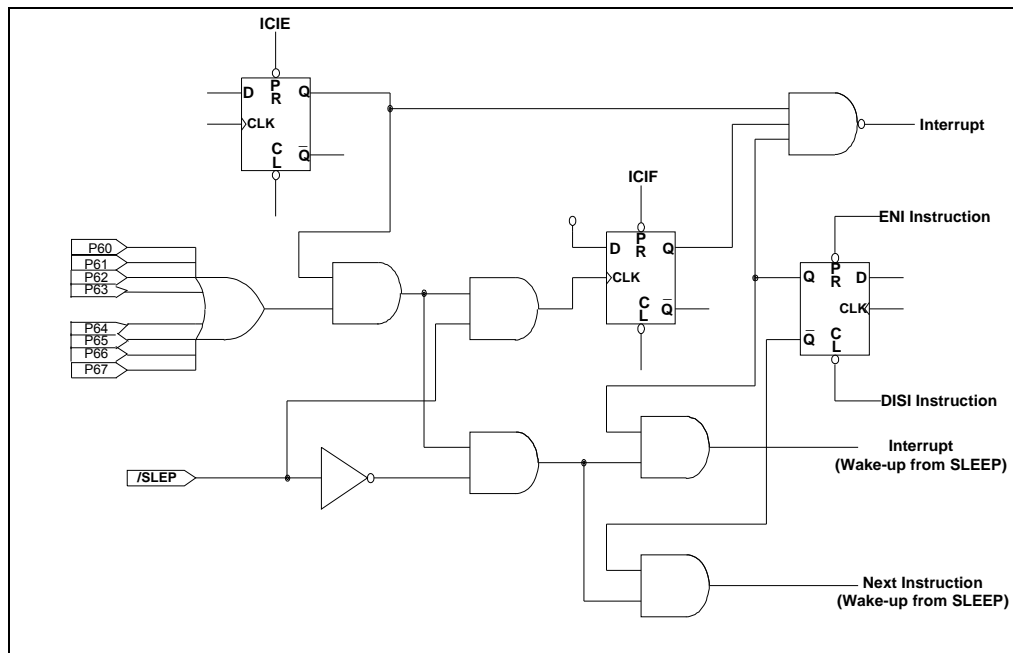

Figure 5-8 Block Diagram of I/O Port 6 with input Change Interrupt/Wake-up

Table 5-1 Usage of Port 6 input change wake-up/interrupt function

Usage of Port 6 Input Status Change Wake-up/Interrupt	
<p>(I) Wake-up from Port 6 Input Status Change</p> <p>(a) Before Sleep</p> <ol style="list-style-type: none"> 1. Disable WDT 2. Read I/O Port 6 (MOV R6,R6) 3. Execute "ENI" or "DISI" 4. Enable interrupt (Set IOCF.1) 5. Execute "SLEP" instruction <p>(b) After Wake-up</p> <ol style="list-style-type: none"> 1. IF "ENI" → Interrupt vector (006H) 2. IF "DISI" → Next instruction 	<p>(II) Port 6 Input Status Change Interrupt</p> <ol style="list-style-type: none"> 1. Read I/O Port 6 (MOV R6,R6) 2. Execute "ENI" 3. Enable interrupt (Set IOCF.1) 4. IF Port 6 change (interrupt) → Interrupt Vector (006H)

5.5 Reset and Wake-up

5.5.1 Reset

Input Status Change

- (1) Power-on reset
- (2) /RESET pin input "low"
- (3) WDT time-out (if enabled)

The device is kept in a reset condition for a period of approx. 18ms² (one oscillator start-up timer period) after a reset is detected. Once a reset occurs, the following functions are performed.

- The oscillator is running, or will be started.
- The Program Counter (R2) is set to all "0".
- All I/O port pins are configured as input mode (high-impedance state).
- The Watchdog timer and prescaler are cleared.
- When power is switched on, the upper 3 bits of R3 are cleared.
- The bits of the CONT register are set to all "1" except for Bit 6 (INT flag).
- The bits of the IOCB register are set to all "1".
- The IOCC register is cleared.
- The bits of the IOCD register are set to all "1".
- Bit 7 of the IOCE register is set to "1", and Bits 6~0 are cleared
- Bits 0~4 of RF and bits 0~4 of IOCF register are cleared.

Sleep (power down) mode is attained by executing the "SLEP" instruction. While entering sleep mode, WDT (if enabled) is cleared but keeps on running. The controller can be awakened by:

- (1) External reset input on the /RESET pin,
- (2) WDT time-out (if enabled), or
- (3) Port 6 input status changes (if enabled).

The first two cases will cause the EM78P163N to reset. The T and P flags of R3 can be used to determine the source of the reset (wake-up). The last case is considered a continuation of program execution and the global interrupt ("ENI" or "DISI" being executed) determines whether or not the controller branches to the interrupt vector following a wake-up. If ENI is executed before SLEP, the instruction will begin to execute from the interrupt vector address after a wake-up. If DISI is executed before SLEP, the operation will restart from the instruction right next to SLEP after a wake-up.

²Vdd = 5V, Setup time period = 16.5ms ± 30%
Vdd = 3V, Setup time period = 18ms ± 30%

Only one of Cases 2 and 3 can be enabled before entering sleep mode. That is,

[a] if Port 6 input status changed interrupt is enabled before SLEP, WDT must be disabled by software. However, the WDT bit in the option register remains enabled. Hence, the EM78P163N can be awakened only by Case 1 or 3.

[b] if WDT is enabled before SLEP, Port 6 Input Status Change Interrupt must be disabled. Hence, the EM78P163N can be awakened only by Case 1 or 2. Refer to the section on *Interrupt*.

If Port 6 Input Status Changed Interrupt is used to wake-up the EM78P163N (Case [a] above), the following instructions must be executed before SLEP:

```
MOV          A, @xxxx1110b    ; Select WDT prescaler,  
                                     ; the prescaler must be set over  
                                     ; 1:1  
  
CONTW  
WDTC                    ; Clear WDT and prescaler  
MOV          A, @xxxxxxxxb    ; Disable WDT  
IOW          RE  
MOV          R6, R6          ; Read Port 6  
MOV          A, @00000x1xb    ; Enable Port 6 input change  
                                     ; interrupt  
  
IOW          RF  
ENI (or DISI)          ; Enable (or disable) global  
                                     ; interrupt  
  
SLEP                    ; Sleep
```

NOTE

1. After waking up from sleep mode, the WDT is automatically enabled. The WDT enable/disable operation after waking up from sleep mode should be properly defined in the software.
2. To avoid a reset from occurring when the Port 6 Input Status Changed Interrupt enters into an interrupt vector or when it is used to wake-up the MCU, the WDT prescaler must be set above the 1:1 ratio.

5.5.2 Wake-up and Interrupt Modes Operation Summary

All categories under Wake-up and Interrupt modes are summarized below.

The controller can be awakened from sleep mode and idle mode. The wake-up signals are listed as follows:

After wake up:

Wake-up Signal	Sleep Mode	Idle Mode	Green Mode	Normal Mode
External interrupt	×	Wake-up + interrupt (if interrupt is enabled) + next instruction	Interrupt (if interrupt is enabled) or next instruction	Interrupt (if interrupt is enabled) or next instruction
Port 6 pin change	If ICWE bit is enabled Wake-up + interrupt (if interrupt is enabled) + next instruction	If ICWE bit is enabled Wake-up + interrupt (if interrupt is enabled) + next instruction	Interrupt (if interrupt is enabled) or next instruction	Interrupt (if interrupt is enabled) or next instruction
TCC overflow interrupt	×	Wake-up + interrupt (if interrupt is enabled) + next instruction	Interrupt (if interrupt is enabled) or next instruction	Interrupt (if interrupt is enabled) or next instruction
Comparator interrupt	If CMPWE bit is enabled Wake-up + interrupt (if interrupt is enabled) + next instruction	If CMPWE bit is enabled Wake-up + interrupt (if interrupt is enabled) + next instruction	Interrupt (if interrupt is enabled) or next instruction	Interrupt (if interrupt is enabled) or next instruction
PWM (When TMR matches PRD)	×	Wake-up + interrupt (if interrupt is enabled) + next instruction	Interrupt (if interrupt is enabled) or next instruction	Interrupt (if interrupt is enabled) or next instruction
WDT Time out	RESET	RESET	RESET	RESET
Low Voltage Reset	RESET	RESET	RESET	RESET

Note: 1. If interrupt is enabled → interrupt+ next instruction

2. If interrupt is disabled → next instruction



Signal	Sleep Mode	Normal Mode
TCC Overflow	N/A	DISI + IOCF0 (TCIE) Bit 0 = 1
		Next Instruction+ Set RF (TCIF) = 1
		ENI + IOCF0 (TCIE) Bit 0 = 1
		Interrupt Vector (0x09)+ Set RF (TCIF) = 1
Port 6 Input Status Change	RE (ICWE) Bit 1 = 0, IOCF0 (ICIE) Bit 1 = 0	IOCF0 (ICIE) Bit 1 = 0
	Oscillator, TCC and TIMERX are stopped. Port 6 input status change wake up is invalid.	Port 6 input status change interrupt is invalid
	RE (ICWE) Bit 1 = 0, IOCF0 (ICIE) Bit 1 = 1	–
	Set RF (ICIF) = 1, Oscillator, TCC and TIMERX are stopped. Port 6 input status change wake up is invalid.	–
	RE (ICWE) Bit 1 = 1, IOCF0 (ICIE) Bit 1 = 0	–
	Wake-up+ Next Instruction Oscillator, TCC and TIMERX are stopped.	–
	RE (ICWE) Bit 1 = 1, DISI + IOCF0 (ICIE) Bit 1 = 1	DISI + IOCF0 (ICIE) Bit 1 = 1
	Wake-up+ Next Instruction+ Set RF (ICIF) = 1 Oscillator, TCC and TIMERX are stopped.	Next Instruction+ Set RF (ICIF) = 1
INT Pin	N/A	DISI + IOCF0 (EXIE) Bit 3 = 1
		Next Instruction+ Set RF (EXIF) = 1
		ENI + IOCF0 (EXIE) Bit 3 = 1
		Interrupt Vector (0x03)+ Set RF (EXIF)=1
PWM (When TMR matches PRD)	N/A	DISI + IOCF0 (PWMIE)=1
		Next Instruction+ Set RF (PWMIF) = 1
		ENI + IOCF0 (PWMIE)=1
		Interrupt Vector (0x0F)+ Set RF (PWMIF) = 1
Comparator (Comparator Output Status Change)	RE (CMPWE) Bit 2 = 0, IOCF0 (CMPIE) Bit 2 = 0	IOCF0 (CMPIE) Bit 7 = 0
	Comparator output status change wake-up is invalid. Oscillator, TCC and TMR are stopped.	Comparator output status change interrupt is invalid.
	RE (CMPWE) Bit 2 = 0, IOCF0 (CMPIE) Bit 2 = 1	
	Set RF (CMPIF) = 1, Comparator output status change wake up is invalid. Oscillator, TCC and TMR are stopped.	
	RE (CMPWE) Bit 2 = 1, IOCF0 (CMPIE) Bit 2 = 0	
	Wake-up+ Next Instruction, Oscillator, TCC and TMR are stopped.	
	RE (CMPWE) Bit 2=1, DISI + IOCF0 (CMPIE) Bit 2 = 1	DISI + IOCF0 (CMPIE) Bit 7 = 1
	Wake-up+ Next Instruction+ Set RF (CMPIF) = 1, Oscillator, TCC and TMR are stopped.	Next Instruction+ Set RF (CMPIF) = 1
RE (CMPWE) Bit 2 = 1, ENI + IOCF0 (CMPIE) Bit 2 = 1	ENI + IOCF0 (CMPIE) Bit 7 = 1	
Wake-up+ Interrupt Vector (0x0C)+ Set RF (CMPIF)=1 Oscillator, TCC and TMR are stopped.	Interrupt Vector (0x0C)+ Set RF (CMPIF) = 1	
WDT Time Out IOCE (WDTE) Bit 7 = 1	Wake-up+ Reset (Address 0x00)	Reset (Address 0x00)



Table 5-2 Summary of the Initialized Register Values

Address	Name	Reset Type	Bit 7	Bit 6	Bit 5	Bit 4	Bit 3	Bit 2	Bit 1	Bit 0
N/A	IOC5	Bit Name	×	×	C55	C54	C53	C52	C51	C50
		Power-on	0	0	1	1	1	1	1	1
		/RESET and WDT	0	0	1	1	1	1	1	1
		Wake-up from Pin Change	0	0	P	P	P	P	P	P
N/A	IOC6	Bit Name	C67	C66	C65	C64	C63	C62	C61	C60
		Power-on	1	1	1	1	1	1	1	1
		/RESET and WDT	1	1	1	1	1	1	1	1
		Wake-up from Pin Change	P	P	P	P	P	P	P	P
0x05	P5	Bit Name	×	×	P55	P54	P53	P52	P51	P50
		Power-on	1	1	1	1	1	1	1	1
		/RESET and WDT	P	P	P	P	P	P	P	P
		Wake-up from Pin Change	P	P	P	P	P	P	P	P
0x06	P6	Bit Name	P67	P66	P65	P64	P63	P62	P61	P60
		Power-on	1	1	1	1	1	1	1	1
		/RESET and WDT	P	P	P	P	P	P	P	P
		Wake-up from Pin Change	P	P	P	P	P	P	P	P
0x07	R7 (TBLP)	Bit Name	–	–	–	–	–	–	–	–
		Power-on	U	U	U	U	U	U	U	U
		/RESET and WDT	P	P	P	P	P	P	P	P
		Wake-up from Pin Change	P	P	P	P	P	P	P	P
N/A	CONT	Bit Name	INTE	INT	TS	TE	PSTE	PST2	PST1	PST0
		Power-on	0	0	0	0	0	0	0	0
		/RESET and WDT	0	0	0	0	0	0	0	0
		Wake-up from Pin Change	P	0	P	P	P	P	P	P
0x00	R0 (IAR)	Bit Name	–	–	–	–	–	–	–	–
		Power-on	U	U	U	U	U	U	U	U
		/RESET and WDT	P	P	P	P	P	P	P	P
		Wake-up from Pin Change	P	P	P	P	P	P	P	P



Address	Name	Reset Type	Bit 7	Bit 6	Bit 5	Bit 4	Bit 3	Bit 2	Bit 1	Bit 0
0x01	R1 (TCC)	Bit Name	–	–	–	–	–	–	–	–
		Power-on	0	0	0	0	0	0	0	0
		/RESET and WDT	0	0	0	0	0	0	0	0
		Wake-up from Pin Change	P	P	P	P	P	P	P	P
0x02	R2 (PC)	Bit Name	–	–	–	–	–	–	–	–
		Power-on	0	0	0	0	0	0	0	0
		/RESET and WDT	0	0	0	0	0	0	0	0
		Wake-up from Pin Change	P	P	P	P	N	P	P	P
0x03	R3 (SR)	Bit Name	RST	GP1	GP0	T	P	Z	DC	C
		Power-on	0	0	0	1	1	U	U	U
		/RESET and WDT	0	0	0	t	t	P	P	P
		Wake-up from Pin Change	1	P	P	t	t	P	P	P
0x04	R4 (RSR)	Bit Name	GP1	GP0	–	–	–	–	–	–
		Power-on	U	U	U	U	U	U	U	U
		/RESET and WDT	P	P	P	P	P	P	P	P
		Wake-up from Pin Change	P	P	P	P	P	P	P	P
~0x09	R9	Bit Name	–	–	–	–	–	–	–	–
		Power-on	U	U	U	U	U	U	U	U
		/RESET and WDT	P	P	P	P	P	P	P	P
		Wake-up from Pin Change	P	P	P	P	P	P	P	P
0x0A	RA (PWMC0N)	Bit Name	–	–	–	PWME	TEN	TP2	TP1	TP0
		Power-on	–	–	–	0	0	0	0	0
		/RESET and WDT	–	–	–	0	0	0	0	0
		Wake-up from Pin Change	–	–	–	P	P	P	P	P
0x0B	RB (CMPCON1)	Bit Name	ACOS1	ACOS0	BCOS1	BCOS0	CCOS1	CCOS0	DCOS1	DCOS0
		Power-on	0	0	0	0	0	0	0	0
		/RESET and WDT	0	0	0	0	0	0	0	0
		Wake-up from Pin Change	P	P	P	P	P	P	P	P



Address	Name	Reset Type	Bit 7	Bit 6	Bit 5	Bit 4	Bit 3	Bit 2	Bit 1	Bit 0
0x0C	RC (CMPCON II)	Bit Name	CRS	CIRL2	CIRL1	CIRL0	CPOUT	COE	CRCS1	CRCS0
		Power-on	0	0	0	0	0	0	0	0
		/RESET and WDT	0	0	0	0	0	0	0	0
		Wake-up from Pin Change	P	P	P	P	P	P	P	P
0x0D	RD (SCR)	Bit Name	TIMERSC	CPUS	IDLE	–	–	–	–	–
		Power-on	0	1	1	0	0	0	0	0
		/RESET and WDT	0	1	1	0	0	0	0	0
		Wake-up from Pin Change	P	P	P	P	P	P	P	P
0x0E	RE (WUCR)	Bit Name	–	–	–	–	–	CMPWE	ICWE	–
		Power-on	0	0	0	0	0	0	0	0
		/RESET and WDT	0	0	0	0	0	0	0	0
		Wake-up from Pin Change	P	P	P	P	P	P	P	P
0x0F	RF (ISR)	Bit Name	–	–	–	PWMIF	EXIF	CMPIF	ICIF	TCIF
		Power-on	0	0	0	0	0	0	0	0
		/RESET and WDT	0	0	0	0	0	0	0	0
		Wake-up from Pin Change	P	P	P	P	P	P	P	P
N/A	IOC7 (TMRH)	Bit Name	–	–	TMR[9]	TMR[8]	PRD[9]	PRD[8]	DT[9]	DT[8]
		Power-on	0	0	0	0	0	0	0	0
		/RESET and WDT	0	0	0	0	0	0	0	0
		Wake-up from Pin Change	P	P	P	P	P	P	P	P
N/A	IOC8 (TMRL)	Bit Name	TMR[7]	TMR[6]	TMR[5]	TMR[4]	TMR[3]	TMR[2]	TMR[1]	TMR[0]
		Power-on	0	0	0	0	0	0	0	0
		/RESET and WDT	0	0	0	0	0	0	0	0
		Wake-up from Pin Change	P	P	P	P	P	P	P	P
N/A	IOC9 (PRDL)	Bit Name	PRD[7]	PRD[6]	PRD[5]	PRD[4]	PRD[3]	PRD[2]	PRD[1]	PRD[0]
		Power-on	0	0	0	0	0	0	0	0
		/RESET and WDT	0	0	0	0	0	0	0	0
		Wake-up from Pin Change	P	P	P	P	P	P	P	P



Address	Name	Reset Type	Bit 7	Bit 6	Bit 5	Bit 4	Bit 3	Bit 2	Bit 1	Bit 0
N/A	IOCA (DTL)	Bit Name	DT[7]	DT[6]	DT[5]	DT[4]	DT[3]	DT[2]	DT[1]	DT[0]
		Power-on	0	0	0	0	0	0	0	0
		/RESET and WDT	0	0	0	0	0	0	0	0
		Wake-up from Pin Change	P	P	P	P	P	P	P	P
N/A	IOCB	Bit Name	×	/PD62	/PD61	/PD60	/PD53	/PD52	/PD51	/PD50
		Power-on	1	1	1	1	1	1	1	1
		/RESET and WDT	1	1	1	1	1	1	1	1
		Wake-up from Pin Change	P	P	P	P	P	P	P	P
N/A	IOCC (ODCR)	Bit Name	OD67	OD66	OD65	OD64	×	OD62	OD61	OD60
		Power-on	0	0	0	0	0	0	0	0
		/RESET and WDT	0	0	0	0	0	0	0	0
		Wake-up from Pin Change	P	P	P	P	P	P	P	P
N/A	IOCD (PHCR)	Bit Name	/PH67	/PH66	/PH65	/PH64	×	/PH62	/PH61	/PH60
		Power-on	1	1	1	1	1	1	1	1
		/RESET and WDT	1	1	1	1	1	1	1	1
		Wake-up from Pin Change	P	P	P	P	P	P	P	P
N/A	IOCE (WDTCR)	Bit Name	WDTE	EIS	PSWE	PSW2	PSW1	PSW0	–	–
		Power-on	0	0	0	0	0	0	0	0
		/RESET and WDT	0	0	0	0	0	0	0	0
		Wake-up from Pin Change	P	P	P	P	P	P	P	P
N/A	IOCF (IMR)	Bit Name	–	–	–	PWMIE	EXIE	CMPIE	ICIE	TCIE
		Power-on	0	0	0	0	0	0	0	0
		/RESET and WDT	0	0	0	0	0	0	0	0
		Wake-up from Pin Change	P	P	P	P	P	P	P	P
0×10 ~0×3F	R10~R3F	Bit Name	–	–	–	–	–	–	–	–
		Power-on	U	U	U	U	U	U	U	U
		/RESET and WDT	P	P	P	P	P	P	P	P
		Wake-up from Pin Change	P	P	P	P	P	P	P	P

Legend : *x* : Not used *U* : Unknown or don't care *P* : Previous value before reset *–* : not defined

5.5.3 /RESET Configure

Refer to Figure 5-8 when the reset bit in the Option word is programmed to 0, the external /RESET is enabled. When programmed to 1, the internal /RESET is enabled, tied to the internal Vdd and the pin is defined as P63.

5.5.4 Status of RST, T, and P of the Status Register

A reset condition is initiated by the following events:

1. Power-on condition
2. High-low-high pulse on /RESET pin
3. Watchdog timer time-out

The values of RST, T and P, listed in Table 5-2 are used to check how the processor wakes up.

Table 5-4 shows the events which may affect the status of RST, T and P.

Table 5-3 Values of RST, T and P after Reset

Reset Type	RST	T	P
Power on	0	1	1
/RESET during Operating mode	0	*P	*P
/RESET wake-up during Sleep mode	0	1	0
WDT during Operating mode	0	0	P
WDT wake-up during Sleep mode	0	0	0
Wake-up on pin change during Sleep mode	1	1	0

*P: Previous status before reset

Table 5-4 Status of RST, T and P being Affected by Events

Event	RST	T	P
Power on	0	1	1
WDTC instruction	*P	1	1
WDT time-out	0	0	*P
SLEP instruction	*P	1	0
Wake-up on pin change during Sleep mode	1	1	0

*P: Previous value before reset

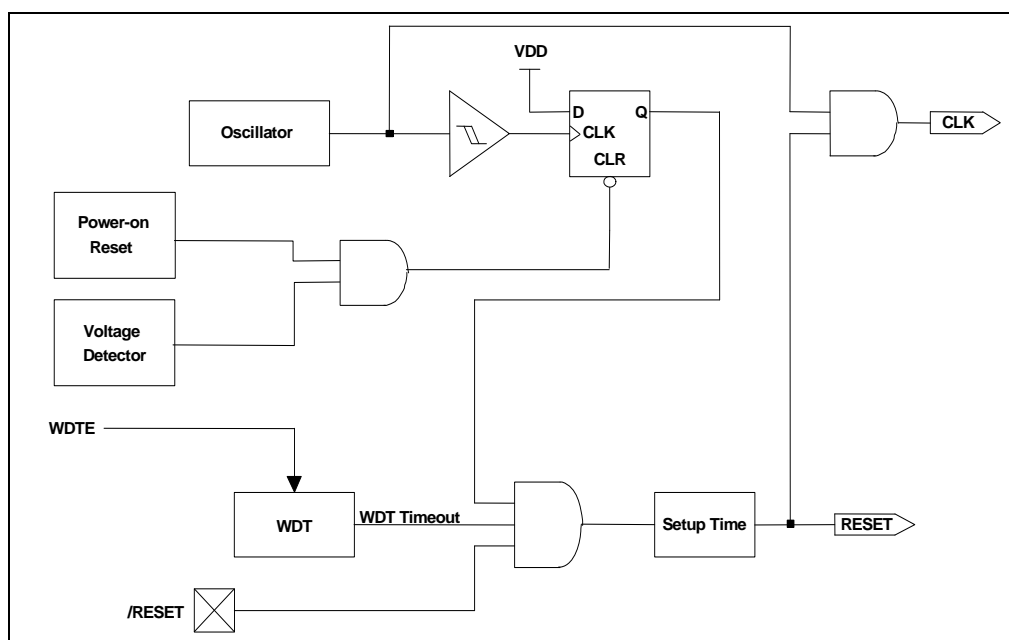

Figure 5-9 Controller Reset Block Diagram

5.6 Interrupt

The EM78P163N has five interrupts as listed below:

- (1) TCC overflow interrupt
- (2) Port 6 Input Status Change Interrupt
- (3) External interrupt [(P60, /INT) pin]
- (4) When TMR matches with PRD respectively in PWM
- (5) When the comparators output changes

Before the Port 6 Input Status Changed Interrupt is enabled, reading Port 6 (e.g. "MOV R6, R6") is necessary. Each pin of Port 6 will have this feature if its status changes. Any pin configured as output or P60 pin configured as /INT, is excluded from this function. The Port 6 Input Status Changed Interrupt can wake up the EM78P163N from sleep mode if Port 6 is enabled prior to going into sleep mode by executing SLEP instruction. When the device wakes-up, the controller will continue to execute the program in-line if the global interrupt is disabled. If the global interrupt is enabled, it will branch to the interrupt Vector 006H.

RF is the interrupt status register that records the interrupt requests in the relative flags/bits. IOCF is an interrupt mask register. The global interrupt is enabled by the ENI instruction and is disabled by the DISI instruction. When one of the interrupts (enabled) occurs, the next instruction will be fetched from interrupt vector address. Once in the interrupt service routine, the source of an interrupt can be determined by polling the flag bits in RF. The interrupt flag bit must be cleared by instructions before leaving the interrupt service routine and before interrupts are enabled to avoid recursive interrupts.

The flag (except ICIF bit) in the Interrupt Status Register (RF) is set regardless of the status of its mask bit or the execution of ENI. Note that the outcome of RF will be the logic AND of RF and IOCF (refer to Figure 5-9). The RETI instruction ends the interrupt routine and enables the global interrupt (execution of ENI).

When an interrupt is generated by the Timer clock / counter (if enabled), the next instruction will be fetched from Address 009H, and 00FH (TCC, Timer 1 respectively).

Before an interrupt subroutine is executed, the contents of ACC and the R3 and R4 registers will be saved by the hardware. If another interrupt occurs, the ACC, R3, and R4 will be replaced by the new interrupt. After the interrupt service routine is completed, the ACC, R3, and R4 registers are restored.

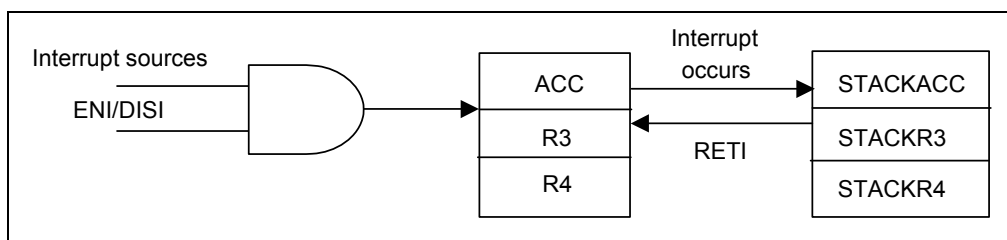

Figure 5-10 Interrupt Backup Diagram

In EM78P163N, each individual interrupt source has its own interrupt vector as depicted in the table below.

Interrupt Vector	Interrupt Status	Priority*
003H	External interrupt	1
006H	Port 6 pin change	2
009H	TCC overflow interrupt	3
00CH	Comparator interrupt	4
00FH	Timer 1 (PWM) overflow interrupt	5

*Priority : 1 = highest ; 5 = lowest priority

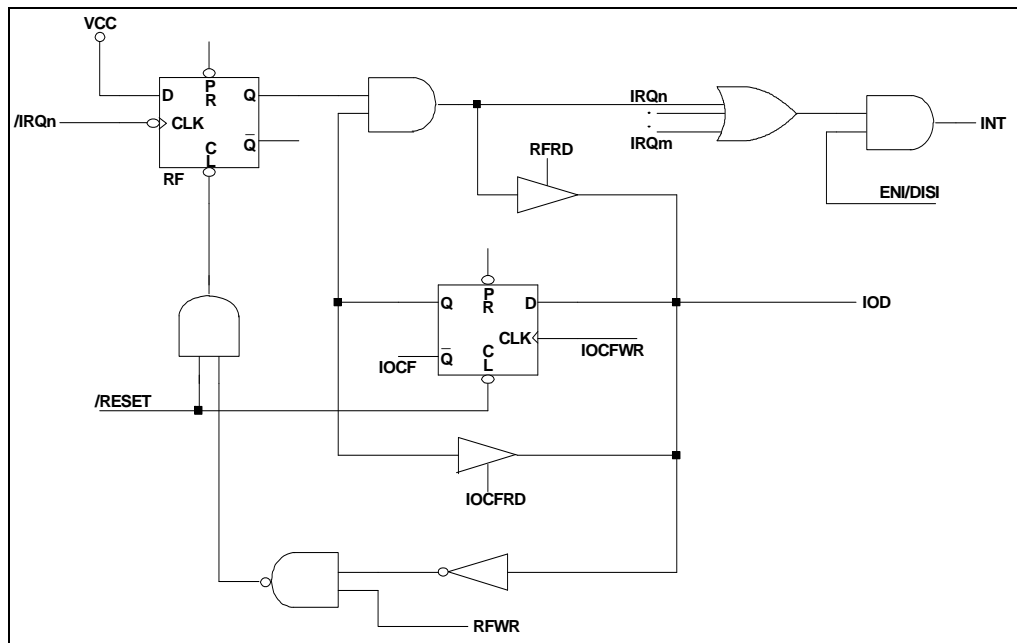

Figure 5-11 Interrupt input Circuit

5.7 PWM (Pulse Width Modulation)

5.7.1 Overview

In PWM mode, PWM pins produce up to a 10-bit resolution PWM output (see the functional block diagram below). A PWM output consists of a time period and a duty cycle, and it keeps the output high. The baud rate of the PWM is the inverse of the time period. Figure 5-13 *PWM Output Timing* depicts the relationships between a time period and a duty cycle.

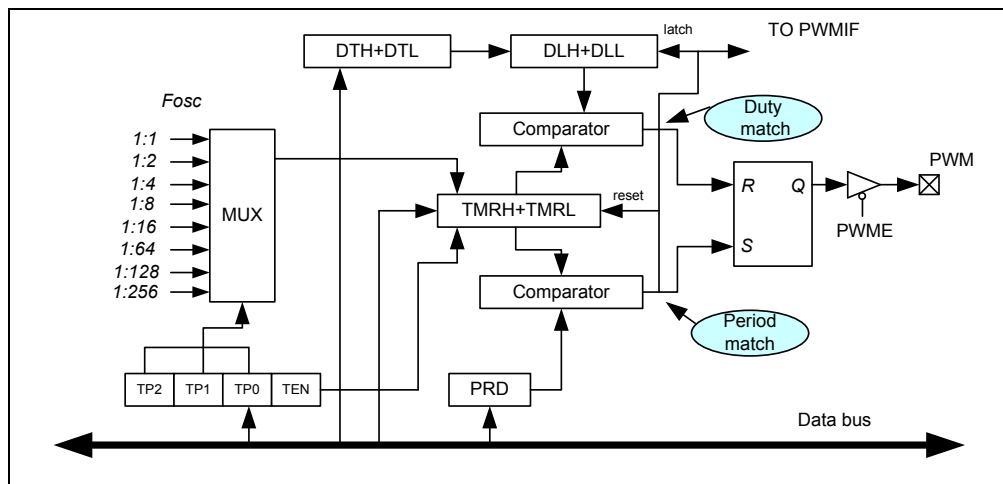

Figure 5-12 PWM Functional Block Diagram

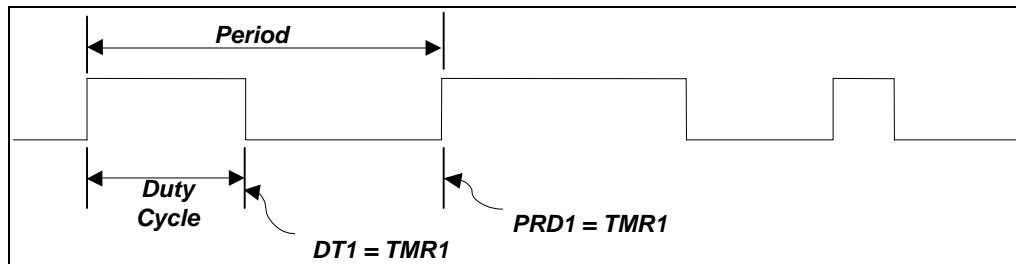

Figure 5-13 PWM Output Timing

5.7.2 Increment Timer Counter (TMRX: TMRH/TMRL)

TMRX are 10-bit clock counters with programmable prescalers. They are designed for the PWM module as baud rate clock generators. TMRX can be read only. If employed, they can be turned off for power saving by setting the T1EN Bit [RB<3>] to 0.

5.7.3 PWM Time Period (PRDX: TMRH/PRDL)

The PWM time period is defined by writing to the PRDL register. When TMRX is equal to PRDX, the following events occur on the next increment cycle:

- TMRX is cleared
- The PWMX pin is set to 1
- The PWM duty cycle is latched from DT to DTL

NOTE

The PWM output will not be set if the duty cycle is 0.

- The PWMIF pin is set to 1

The following formula describes how to calculate the PWM Time Period:

$$Period = (PRDX + 1) \times \left(\frac{1}{F_{osc}} \right) \times (TMRX \text{ prescale value})$$

Example:

PRDX = 49; Fosc = 4 MHz; TMRX (0, 0, 0) = 1 : 1,

Then

$$Period = (49 + 1) \times \left(\frac{1}{4M} \right) \times = 12.5 \mu s$$

5.7.4 PWM Duty Cycle (DTX: TMRH/DTL)

The PWM duty cycle is defined by writing to the DTX register, and is latched from DTX to DLX while TMRX is cleared. When DLX is equal to TMRX, the PWMX pin is cleared. DTX can be loaded anytime. However, it cannot be latched into DLX until the current value of DLX is equal to TMRX.

The following formula describes how to calculate the PWM duty cycle:

$$\text{Duty cycle} = (DTX) \times \left(\frac{1}{F_{osc}} \right) \times (TMRX \text{ prescale value})$$

Example:

DTX = 10; Fosc = 4 MHz; TMRX (0, 0, 0) = 1 : 1,

Then

$$\text{Duty cycle} = (10) \times \left(\frac{1}{4M} \right) \times = 2.5 \mu\text{s}$$

5.7.5 Comparator

Changing the output status while a match occurs will set the TMRIF flag at the same time.

5.7.6 PWM Programming Process/Steps

Load PRD with the PWM time period.

1. Load DT with the PWM Duty Cycle.
2. Enable interrupt function by writing IOCF0, if required.
3. Set PWMX pin to be output by writing a desired value to RB.
4. Load a desired value to IOC9 with TMR prescaler value and enable both PWM and TMR.

5.8 Timer

5.8.1 Overview

The Timer (TMRX) is a 10-bit clock counter with programmable prescalers. It is designed for the PWM module as baud rate clock generator. TMRX can be read only. The Timer will stop running when sleep mode occurs.

5.8.2 Function Description

The following figure shows the TMRX block diagram followed by descriptions of its signals and blocks:

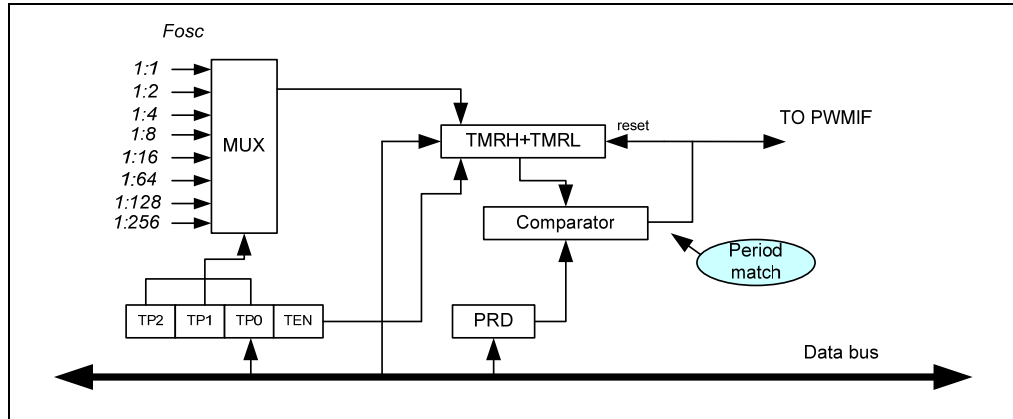

Figure 5-14 TMRX Block Diagram

Fosc: Input clock.

Prescaler (TP2, TP1 and TP0): The Options 1:1, 1:2, 1:4, 1:8, 1:16, 1:64, 1:128, and 1:256 are defined by TMR. It is cleared when any type of reset occurs.

TMR (TMRH/TMRL): Timer register; TMR is increased until it matches with PRD, and then it is reset to 1 (default value).

PRD: PWM time period register.

Comparator: Reset TMR while a match occurs. The TMRIF flag is set at the same time.

5.8.3 Programming the Related Registers

When defining TMR, refer to the operation of its related registers as shown in the table below. It must be noted that the PWM bits must be disabled if their related TMR are employed. That is, Bit 4 of the PWMCON register must be set to '0'.

5.8.3.1 TMR Related Control Registers

Addr.	Name	Bit 7	Bit 6	Bit 5	Bit 4	Bit 3	Bit 2	Bit 1	Bit 0
0x0B	PWMCON/RB	CPOUT	COS1	COS0	PWME	TEN	TP2	TP1	TP0

5.8.4 Timer Programming Process/Steps

1. Load PRD with the Timer duration
2. Enable interrupt function by writing IOCF0, if required
3. Load a desired TMR prescaler value to PWMCON, enable TMR and disable PWM

5.9 Comparator

The EM78P163N has one comparator comprising of five analog inputs and one output. The comparator can be utilized to wake up the EM78P163N from sleep mode. The comparator circuit diagram is depicted in the figure below.

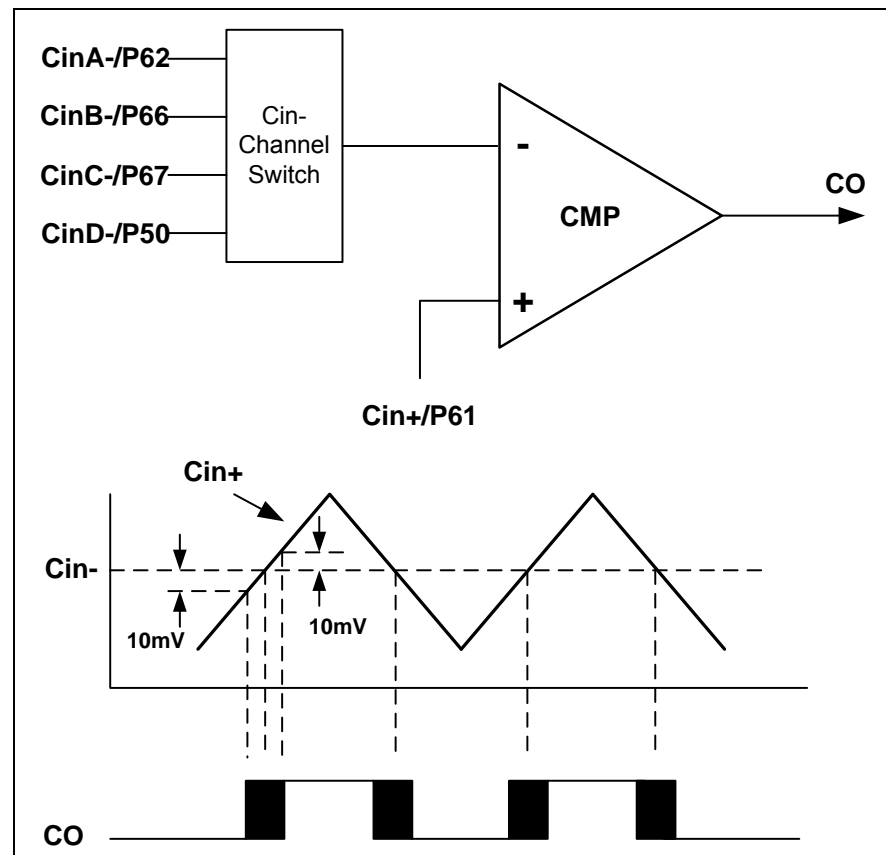

Figure 5-15 Comparator Circuit Diagram and Operating Mode

5.9.1 External Reference Signal

The analog signal that is presented at CinX– compares to the signal at Cin+, and the digital output (CO) of the comparator is adjusted accordingly by taking the following notes into considerations:

NOTE

- The reference signal must be between V_{ss} and V_{dd} .
- The reference voltage can be applied to either pin or comparator.
- Threshold detector applications may be of the same reference.
- The comparator can operate from the same or different reference sources.

5.9.2 Comparator Outputs

- The compared result is stored in the CPOUT of RB.
- The comparator outputs are sent to CO (P60) by programming Bit 1, Bit 0 <COS1, COS0> of the RB register to <1, x>. See Section 6.2.6, RB for Comparator select bits function description.

NOTE

- The CO and PWM of the P60/INT/CO pins cannot be used at the same time.
- The P60/INT/CO pin priority is as follows:

P60/INT/CO Priority		
High	Medium	Low
CO	INT	P60

The following figure shows the Comparator Output block diagram.

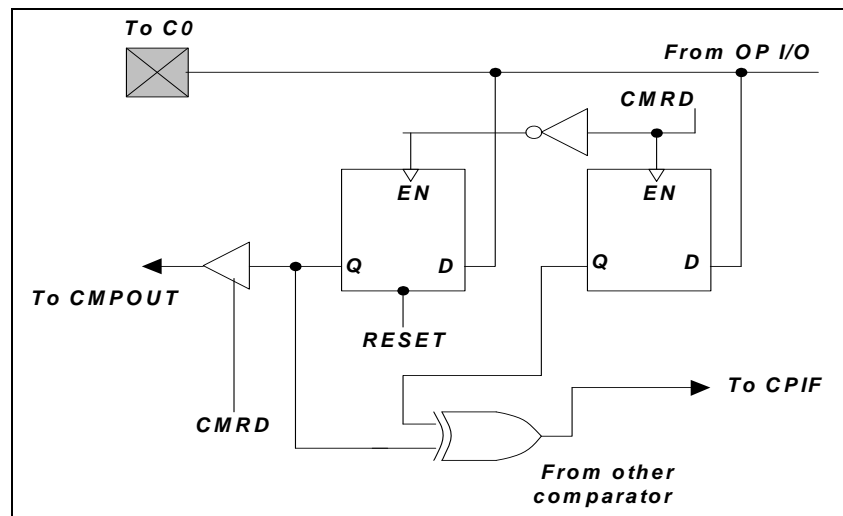

Figure 5-16 Comparator Output Configuration

5.9.3 Comparator Interrupt

- CMPIE (IOCF0.3) must be enabled for the “ENI” instruction to take effect.
- Interrupt is triggered whenever a change occurs on the comparator output pin.
- The actual change on the pin can be determined by reading the Bit CPOUT, RB<2>.
- CMPIF (RF.3), the comparator interrupt flag, can only be cleared by software.



5.9.4 Wake-up from Sleep Mode

- If enabled, the comparator remains active and the interrupt remains functional, even in Sleep mode.
- If a mismatch occurs, the interrupt will wake up the device from Sleep mode.
- Power consumption should be taken into consideration for the benefit of energy conservation.
- If the function is not implemented during Sleep mode, turn off the comparator before entering into sleep mode.

5.10 Oscillator

5.10.1 Oscillator Modes

The EM78P163N can be operated in four different oscillator modes, such as High Crystal oscillator mode (HXT), Low Crystal oscillator mode (LXT), External RC oscillator mode (ERC), and RC oscillator mode with Internal RC oscillator mode (IRC). One of the four modes can be selected by programming the OSC3, OSC2, OCS1, and OSC0 in the Code Option register.

The Oscillator modes defined by OSC3, OSC2, OCS1, and OSC0 are described below.

Oscillator Modes	OSC3	OSC2	OSC1	OSC0
ERC ¹ (External RC oscillator mode); P64/OSCO functions as P64	0	0	0	0
ERC ¹ (External RC oscillator mode); P64/OSCO functions as OSC0	0	0	0	1
IRC ² (Internal RC oscillator mode); P64/OSCO functions as P64	0	0	1	0
IRC ² (Internal RC oscillator mode); P64/OSCO functions as OSC0	0	0	1	1
LXT1 (Frequency range of LXT1 mode is 100kHz ~ 1 MHz)	0	1	0	0
HXT1 (Frequency range of HXT mode is 12 MHz ~ 20 MHz)	0	1	0	1
LXT2 (Frequency range of XT mode is 32kHz)	0	1	1	0
HXT2 (Frequency range of XT mode is 6 MHz ~ 12 MHz)	0	1	1	1
XT (Frequency range of XT mode is 1 MHz ~ 6 MHz) (default)	1	1	1	1

¹ In ERC mode, OSC1 is used as oscillator pin. OSC0/P64 is defined by Code Option Word 0 Bit 9 ~ Bit 6.

² In IRC mode, P65 is normal I/O pin. OSC0/P64 is defined by Code Option Word 0 Bit 9 ~ Bit 6.

The maximum operating frequency limit of the crystal/resonator at different VDDs, are as follows:

Conditions	VDD	Max. Freq. (MHz)
Two clocks	2.3	4
	4.5	16

5.10.2 Crystal Oscillator/Ceramic Resonator (Crystal)

The EM78P163N can be driven by an external clock signal through the OSCO pin as illustrated below.

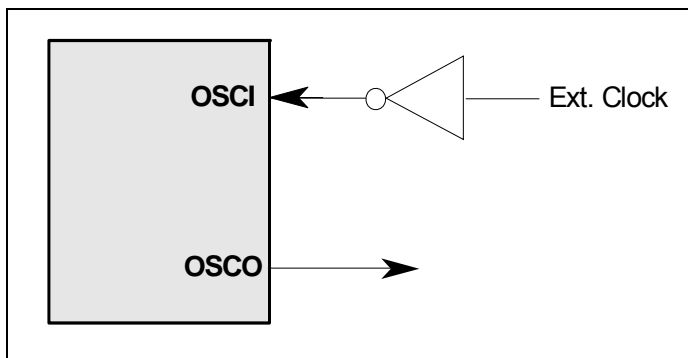

Figure 5-17 External Clock Input Circuit

In most applications, Pin OSCI and Pin OSCO can be connected with a crystal or ceramic resonator to generate oscillation. Figure 5-18 depicts such a circuit. The same applies to the HXT mode and the LXT mode.

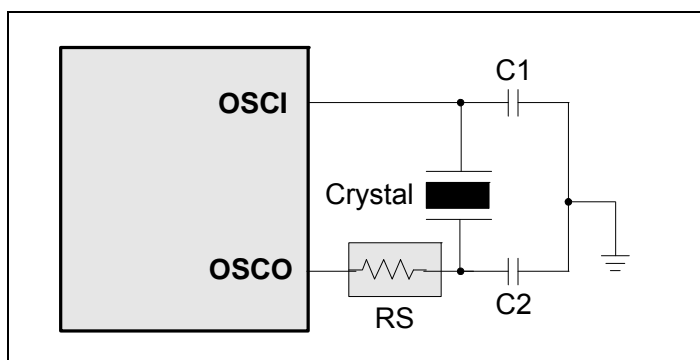

Figure 5-18 Crystal/Resonator Circuit

The following table provides the recommended values for C1 and C2. Since each resonator has its own attribute, refer to the resonator specifications for appropriate values of C1 and C2. RS, a serial resistor, may be required for AT strip cut crystal or low frequency mode.

Capacitor selection guide for crystal oscillator or ceramic resonators:

Oscillator Type	Frequency Mode	Frequency	C1 (pF)	C2 (pF)
Ceramic Resonators	HXT	455kHz	100~150	100~150
		2.0 MHz	20~40	20~40
		4.0 MHz	10~30	10~30
Crystal Oscillator	LXT	32.768kHz	25	15
		100kHz	25	25
		200kHz	25	25
	HXT	455kHz	20~40	20~150
		1.0 MHz	15~30	15~30
		2.0 MHz	15	15
		4.0 MHz	15	15

5.10.3 External RC Oscillator Mode

For some applications that do not require precise timing calculation, the RC oscillator (Figure 5-19) offers an effective cost savings. Nevertheless, it should be noted that the frequency of the RC oscillator is influenced by the supply voltage, the values of the resistor (R_{ext}), the capacitor (C_{ext}), and even by the operation temperature. Moreover, the frequency also changes slightly from one chip to another due to manufacturing process variations.

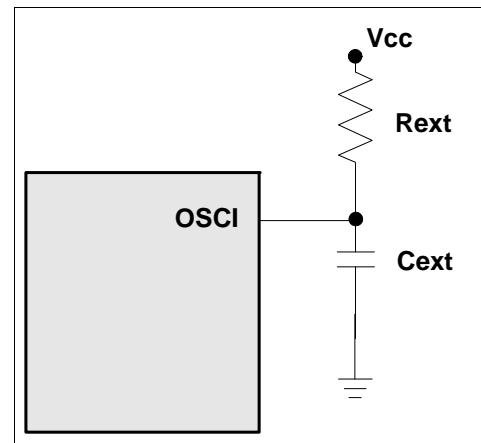

Figure 5-19 External RC Oscillator Mode Circuit

In order to maintain a stable system frequency, the values of the C_{ext} should be no less than 20pF, and the value of R_{ext} should not be greater than 1 M Ω . If the frequency cannot be kept within this range, it can be affected easily by noise, humidity, and leakage.

The smaller the R_{ext} in the RC oscillator is, the faster its frequency will be. On the contrary, for very low R_{ext} values, for instance, 1 K Ω , the oscillator will become unstable because the NMOS cannot discharge the capacitance current correctly.

Based on the above reasons, it must be kept in mind that all supply voltage, operation temperature, components of the RC oscillator, package type, and PCB layout, have certain effect on the system frequency.

The RC Oscillator frequencies:

Cext	Rext	Average Fosc 5V, 25°C	Average Fosc 3V, 25°C
20 Pf	3.3k	3.5 MHz	3.0 MHz
	5.1k	2.4 MHz	2.2 MHz
	10k	1.27 MHz	1.24 MHz
	100k	140kHz	143kHz
100 Pf	3.3k	1.21 MHz	1.18 MHz
	5.1k	805kHz	790kHz
	10k	420kHz	418kHz
	100k	45kHz	46kHz
300 Pf	3.3k	550kHz	526kHz
	5.1k	364kHz	350kHz
	10k	188kHz	185kHz
	100k	20kHz	20kHz

Note: ¹: Measured based on DIP packages.
²: The values are for design reference only.
³: The frequency drift is $\pm 30\%$

5.10.4 Internal RC Oscillator Mode

The EM78P163N offers a versatile internal RC mode with default frequency value of 4 MHz. Internal RC oscillator mode has other frequencies (16 MHz, 8 MHz, and 455kHz) that can be set by Code Option (Word 1), RCM1, and RCM0. The Table below describes the EM78P163N internal RC drift with voltage, temperature, and process variations.

Internal RC Drift Rate ($T_a=25^\circ\text{C}$, $V_{DD}=5V\pm 5\%$, $V_{SS}=0V$)

Internal RC Frequency	Drift Rate			
	Temperature (-40°C ~ +85°C)	Voltage (2.3V~5.5V)	Process	Total
16 MHz	$\pm 6\%$	$\pm 5\%$	$\pm 3\%$	$\pm 14\%$
8 MHz	$\pm 5\%$	$\pm 5\%$	$\pm 3\%$	$\pm 13\%$
4 MHz	$\pm 5\%$	$\pm 5\%$	$\pm 3\%$	$\pm 13\%$
455kHz	$\pm 5\%$	$\pm 5\%$	$\pm 3\%$	$\pm 13\%$

Note : These are theoretical values which are provided for reference only. Actual values may vary depending on the actual process.



Table 5-5 Calibration Selection for Internal RC Mode

C4	C3	C2	C1	C0	*Frequency (MHz)
0	0	0	0	0	(1-24.2%) x F
0	0	0	0	1	(1-23.1%) x F
0	0	0	1	0	(1-21.9%) x F
0	0	0	1	1	(1-20.6%) x F
0	0	1	0	0	(1-19.4%) x F
0	0	1	0	1	(1-18%) x F
0	0	1	1	0	(1-16.7%) x F
0	0	1	1	1	(1-15.3%) x F
0	1	0	0	0	(1-13.8%) x F
0	1	0	0	1	(1-12.3%) x F
0	1	0	1	0	(1-10.7%) x F
0	1	0	1	1	(1-9.1%) x F
0	1	1	0	0	(1-7.4%) x F
0	1	1	0	1	(1-5.7%) x F
0	1	1	1	0	(1-3.8%) x F
0	1	1	1	1	(1-2%) x F
1	1	1	1	1	F (default)
1	1	1	1	0	(1+2%) x F
1	1	1	0	1	(1+4.2%) x F
1	1	1	0	0	(1+6.4%) x F
1	1	0	1	1	(1+8.7%) x F
1	1	0	1	0	(1+11.1%) x F
1	1	0	0	1	(1+13.6%) x F
1	1	0	0	0	(1+16.3%) x F
1	0	1	1	1	(1+19%) x F
1	0	1	1	0	(1+22%) x F
1	0	1	0	1	(1+25%) x F
1	0	1	0	0	(1+28.2%) x F
1	0	0	1	1	(1+31.6%) x F
1	0	0	1	0	(1+35.1%) x F
1	0	0	0	1	(1+38.9%) x F
1	0	0	0	0	(1+42.9%) x F

* These are theoretical values which are provided for reference only. Actual values may vary depending on the actual process.

5.11 Power-on Considerations

Any microcontroller is not warranted to start operating properly before the power supply has stabilized to a steady state. The EM78P163N has a built-in Power-on Reset (POR) with reset level range of 1.7V to 1.9V. The circuitry eliminates the extra external reset circuit. It will work well if Vdd rises quickly enough (50 ms or less). However, under critical applications, extra devices are still required to assist in solving power-on problems.

5.11.1 External Power-on Reset Circuit

The circuits shown in the figure implement an external RC to produce a reset pulse. The pulse width (time constant) should be kept long enough to allow Vdd to reach the minimum operating voltage. This circuit is used when the power supply has a slow power rise time. Because

the current leakage from the /RESET pin is $\pm 5 \mu\text{A}$, it is recommended that R should not be greater than 40K. This way, the voltage at Pin /RESET is held below 0.2V. The diode (D) functions as a short circuit at power-down. The "C" capacitor is discharged rapidly and fully. Rin, the current-limited resistor, prevents high current discharge or ESD (electrostatic discharge) from flowing into Pin /RESET.

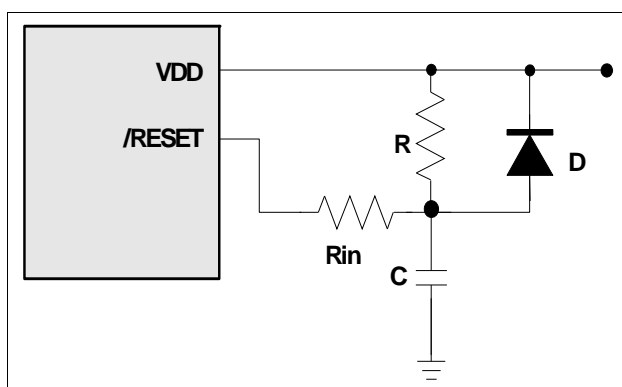

Figure 5-20 External Power-on Reset Circuit

5.11.2 Residual Voltage Protection

When the battery is replaced, device power (V_{dd}) is removed but residual voltage remains. The residual voltage may trip below V_{dd} minimum, but not to zero. This condition may cause a poor power-on reset. Figure 5-21 and Figure 5-22 show how to create a protection circuit against residual voltage.

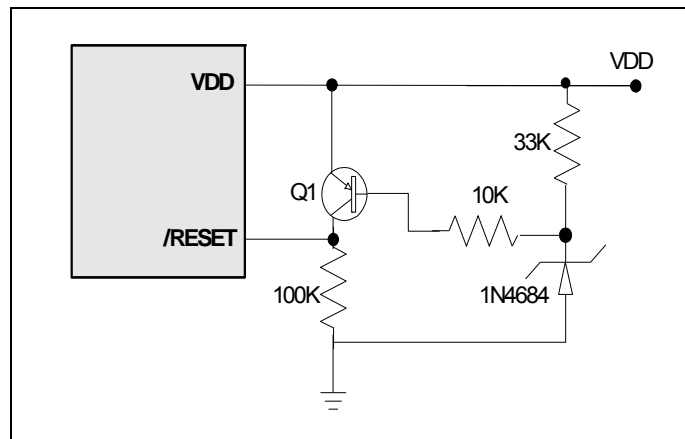

Figure 5-21 Residual Voltage Protection Circuit 1

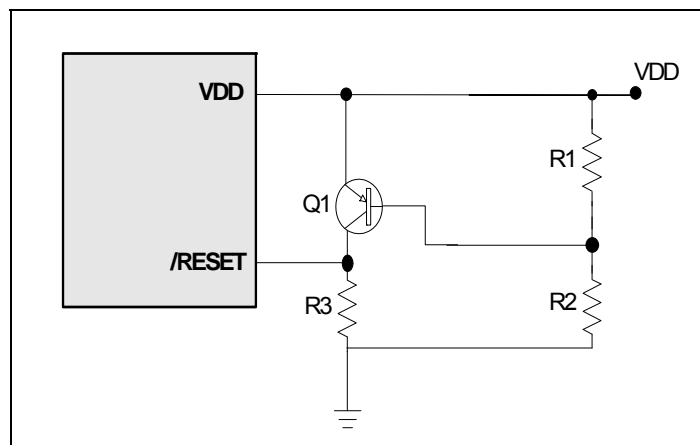

Figure 5-22 Residual Voltage Protection Circuit 2

5.12 Code Option Register

The EM78P163N has Code Option words that are not part of the normal program memory. The option bits cannot be accessed during normal program execution.

Code Option Register and Customer ID Register arrangement distribution:

Word 0	Word 1	Word 2
Bit 12~Bit 0	Bit 12~Bit 0	Bit 12~Bit 0

5.12.1 Code Option Register (Word 0)

Word 0													
Bit	Bit 12	Bit 11	Bit 10	Bit 9	Bit 8	Bit 7	Bit 6	Bit 5	Bit 4	Bit 3	Bit 2	Bit 1	Bit 0
Mnemonic	0	CLKS	TYPE1	TYPE0	LVR1	LVR0	RESETDG	ENWDT	NRHL	NRE	PR2	PR1	PR0
1	-	4CLKS	High	High	High	High	Disable	Disable	32/fc	Disable	Disable		
0	-	2LCKS	Low	Low	Low	Low	Enable	Enable	8/fc	Enable	Enable		

Bit 12: Unused bit, set to 0 all the time

Bit 11 (CLKS): Instruction period selection bit

0 : Two oscillator periods

1 : Four oscillator periods

Refer to the Instruction Set section.

Bits 10 ~ 9 (TYPE1 ~ TYPE0): Type selection for EM78P163N

TYPE1, TYPE0	Selection No.
1X	EM78P163N-16pin
01	EM78P163N-14pin
00	Reserved

Bits 8 ~ 7 (LVR1 ~ LVR0): Low Voltage Reset enable bits

LVR1, LVR0	VDD Reset Level	VDD Release Level
11	NA (Power-on Reset)	
10	2.4V	2.6V
01	3.3V	3.5V
00	4.0V	4.2V

Bit 6 (RESETDG): Reset pin delete glitch function

0: Enable

1: Disable

Bit 5 (ENWDT): Watchdog timer enable bit.

0: Enable Watchdog timer

1: Disable Watchdog timer

NOTE

This bit must enable the WDTE reg. (IOCE reg). Bit 7 must be disabled when Port 6 pin change wake-up function is used.

Bit 4 (NRHL): Noise rejection high/low pulse defined bit

0 : Pulses equal to 8/fc [s] is regarded as signal

1 : Pulses equal to 32/fc [s] is regarded as signal



Bit 3 (NRE): Noise rejection enable bit
0 : Disable noise rejection
1 : Enable noise rejection

Bits 2 ~ 0 (PR2 ~ PR0): Protect Bits

5.12.2 Code Option Register (Word 1)

Word 1													
Bit	Bit 12	Bit 11	Bit 10	Bit 9	Bit 8	Bit 7	Bit 6	Bit 5	Bit 4	Bit 3	Bit 2	Bit 1	Bit 0
Mnemonic	HLP	C4	C3	C2	C1	C0	RCM1	RCM0	OSC3	OSC2	OSC1	OSC0	RCOUT
1	Low	High	High	High	High	High	High	High	High	High	High	High	System clock
0	High	Low	Low	Low	Low	Low	Low	Low	Low	Low	Low	Low	Open drain

Bit 12 (HLP): High/Low power mode
0 : Low power mode
1 : High power mode (default)

Bits 11 ~ 7 (C4 ~ C0): Calibrator of internal RC mode. These bits must always be set to "1" only (auto calibration)

Bits 6 ~ 5 (RCM1 ~ RCM0): RC mode select bits

RCM 1	RCM 0	Frequency (MHz)
1	1	4
1	0	16
0	1	8
0	0	455kHz

Bits 4~1 (OSC3 ~ OSC0): Oscillator mode select bits

Oscillator Modes	OSC3	OSC2	OSC1	OSC0
ERC ¹ (External RC oscillator mode); P64/OSCO functions as P64	0	0	0	0
ERC ¹ (External RC oscillator mode); P64/OSCO functions as OSC0	0	0	0	1
IRC ² (Internal RC oscillator mode); P64/OSCO functions as P64	0	0	1	0
IRC ² (Internal RC oscillator mode); P64/OSCO functions as OSC0	0	0	1	1
LXT1 (Frequency range of LXT1 mode is 100kHz ~ 1 MHz)	0	1	0	0
HXT1 (Frequency range of HXT mode is 12 MHz ~ 20 MHz)	0	1	0	1
LXT2 (Frequency range of XT mode is 32kHz)	0	1	1	0
HXT2 (Frequency range of XT mode is 6 MHz ~ 12 MHz.)	0	1	1	1
XT (Frequency range of XT mode is 1 MHz ~ 6 MHz) (default)	1	1	1	1

Bit 0 (RCOUT): Select bit of Oscillator output or I/O port.

RCOUT	Pin Function
0	OSCO pin is open drain
1	OSCO output system clock (default)

5.12.3 Customer ID Register (Word 2)

Word 2													
Bit	Bit 12	Bit 11	Bit 10	Bit 9	Bit 8	Bit 7	Bit 6	Bit 5	Bit 4	Bit 3	Bit 2	Bit 1	Bit 0
Mnemonic	1	1	CMP_DE	1	RESETEN	EFT_SEL	SUT0	1	1	1	1	1	1
1	-	-	High	-	P63	Long	18ms	-	-	-	-	-	-
0	-	-	Low	-	/RST	Short	4.5ms	-	-	-	-	-	-

Bit 12 (Unused): Unused bit, set to 1 all the time

Bit 11 (Unused): Unused bit, set to 1 all the time

Bit 10 (CMP_DE): Comparator de-glitch enable bit

0 : Disable

1 : Enable

Bit 9 (Unused): Unused bit, set to 1 all the time

Bit 8 (RESETEN): P63//RST pin select bit

0 : P63//RST set to /RST pin

1 : P63//RST set to P63 pin

Bit 7 (EFT_SEL): EFT hold time selection

0 : Short hold time $8 \mu\text{s} \times 16$

1 : Long hold time $8 \mu\text{s} \times 64$

Bit 6 (SUT0): Set up time select bit

0 : 4.5 ms

1 : 18 ms

Bit 5 ~ Bit 0: Unused bit, set to 1 all the time

5.13 Instruction Set

Each instruction in the instruction set is a 13-bit word divided into an OP code and one or more operands. Normally, all instructions are executed within one single instruction cycle (one instruction consists of 2 oscillator periods), unless the program counter is changed by instruction "MOV R2,A", "ADD R2,A", or by instructions of arithmetic or logic operation on R2 (e.g. "SUB R2,A", "BS(C) R2,6", "CLR R2", etc.). In this case, the execution takes two instruction cycles.

If for some reasons, the specification of the instruction cycle is not suitable for certain applications, try modifying the instruction as follows:

- (A) Modify one instruction cycle to consist of 4 oscillator periods.
- (B) Execute within two instruction cycles the "JMP", "CALL", "RET", "RETL", "RETI" commands, or the conditional skip ("JBS", "JBC", "JZ", "JZA", "DJZ", "DJZA") which were tested to be true. The instructions that are written to the program counter, should also take two instruction cycles.

Case (A) is selected by the Code Option bit, called CLKS. One instruction cycle will consist of two oscillator clocks if CLKS is Low, and four oscillator clocks if CLKS is high.

Note that once the 4 oscillator periods within one instruction cycle is selected under Case (A), the internal clock source to TCC should be $CLK = Fosc/4$, instead of $Fosc/2$ as illustrated in Figure 5-3.

In addition, the instruction set has the following features:

- (1) Every bit of any register can be set, cleared, or tested directly.
- (2) The I/O register can be regarded as general register. That is, the same instruction can operate on the I/O register.



Convention:

R = Register designator that specifies which one of the registers (including operation and general purpose registers) is to be utilized by the instruction.

b = Bit field designator that selects the value for the bit located in the register *R* and which affects the operation.

k = 8 or 10-bit constant or literal value

Binary Instruction	Hex	Mnemonic	Operation	Status Affected
0 0000 0000 0000	0000	NOP	No Operation	None
0 0000 0000 0001	0001	DAA	Decimal Adjust A	C
0 0000 0000 0010	0002	CONTW	A → CONT	None
0 0000 0000 0011	0003	SLEP	0 → WDT, Stop oscillator	T, P
0 0000 0000 0100	0004	WDTC	0 → WDT	T, P
0 0000 0000 rrrr	000r	IOW R	A → IOCR	None ¹
0 0000 0001 0000	0010	ENI	Enable Interrupt	None
0 0000 0001 0001	0011	DISI	Disable Interrupt	None
0 0000 0001 0010	0012	RET	[Top of Stack] → PC	None
0 0000 0001 0011	0013	RETI	[Top of Stack] → PC, Enable Interrupt	None
0 0000 0001 0100	0014	CONTR	CONT → A	None
0 0000 0001 rrrr	001r	IOR R	IOCR → A	None ¹
0 0000 01rr rrrr	00rr	MOV R,A	A → R	None
0 0000 1000 0000	0080	CLRA	0 → A	Z
0 0000 11rr rrrr	00rr	CLR R	0 → R	Z
0 0001 00rr rrrr	01rr	SUB A,R	R-A → A	Z, C, DC
0 0001 01rr rrrr	01rr	SUB R,A	R-A → R	Z, C, DC
0 0001 10rr rrrr	01rr	DECA R	R-1 → A	Z
0 0001 11rr rrrr	01rr	DEC R	R-1 → R	Z
0 0010 00rr rrrr	02rr	OR A,R	A ∨ VR → A	Z
0 0010 01rr rrrr	02rr	OR R,A	A ∨ VR → R	Z
0 0010 10rr rrrr	02rr	AND A,R	A & R → A	Z
0 0010 11rr rrrr	02rr	AND R,A	A & R → R	Z
0 0011 00rr rrrr	03rr	XOR A,R	A ⊕ R → A	Z
0 0011 01rr rrrr	03rr	XOR R,A	A ⊕ R → R	Z
0 0011 10rr rrrr	03rr	ADD A,R	A + R → A	Z, C, DC
0 0011 11rr rrrr	03rr	ADD R,A	A + R → R	Z, C, DC

Binary Instruction	Hex	Mnemonic	Operation	Status Affected
0 0100 00rr rrrr	04rr	MOV A,R	$R \rightarrow A$	Z
0 0100 01rr rrrr	04rr	MOV R,R	$R \rightarrow R$	Z
0 0100 10rr rrrr	04rr	COMA R	$\neg R \rightarrow A$	Z
0 0100 11rr rrrr	04rr	COM R	$\neg R \rightarrow R$	Z
0 0101 00rr rrrr	05rr	INCA R	$R+1 \rightarrow A$	Z
0 0101 01rr rrrr	05rr	INC R	$R+1 \rightarrow R$	Z
0 0101 10rr rrrr	05rr	DJZA R	$R-1 \rightarrow A$, skip if zero	None
0 0101 11rr rrrr	05rr	DJZ R	$R-1 \rightarrow R$, skip if zero	None
0 0110 00rr rrrr	06rr	RRCA R	$R(n) \rightarrow A(n-1)$, $R(0) \rightarrow C$, $C \rightarrow A(7)$	C
0 0110 01rr rrrr	06rr	RRC R	$R(n) \rightarrow R(n-1)$, $R(0) \rightarrow C$, $C \rightarrow R(7)$	C
0 0110 10rr rrrr	06rr	RLCA R	$R(n) \rightarrow A(n+1)$, $R(7) \rightarrow C$, $C \rightarrow A(0)$	C
0 0110 11rr rrrr	06rr	RLC R	$R(n) \rightarrow R(n+1)$, $R(7) \rightarrow C$, $C \rightarrow R(0)$	C
0 0111 00rr rrrr	07rr	SWAPA R	$R(0-3) \rightarrow A(4-7)$, $R(4-7) \rightarrow A(0-3)$	None
0 0111 01rr rrrr	07rr	SWAP R	$R(0-3) \leftrightarrow R(4-7)$	None
0 0111 10rr rrrr	07rr	JZA R	$R+1 \rightarrow A$, skip if zero	None
0 0111 11rr rrrr	07rr	JZ R	$R+1 \rightarrow R$, skip if zero	None
0 100b brrr rrrr	0xxx	BC R,b	$0 \rightarrow R(b)$	None ²
0 101b brrr rrrr	0xxx	BS R,b	$1 \rightarrow R(b)$	None ³
0 110b brrr rrrr	0xxx	JBC R,b	if $R(b)=0$, skip	None
0 111b brrr rrrr	0xxx	JBS R,b	if $R(b)=1$, skip	None
1 00kk kkkk kkkk	1kkk	CALL k	$PC+1 \rightarrow [SP]$, (Page, k) $\rightarrow PC$	None
1 01kk kkkk kkkk	1kkk	JMP k	(Page, k) $\rightarrow PC$	None
1 1000 kkkk kkkk	18kk	MOV A,k	$k \rightarrow A$	None
1 1001 kkkk kkkk	19kk	OR A,k	$A \vee k \rightarrow A$	Z
1 1010 kkkk kkkk	1Akk	AND A,k	$A \& k \rightarrow A$	Z
1 1011 kkkk kkkk	1Bkk	XOR A,k	$A \oplus k \rightarrow A$	Z
1 1100 kkkk kkkk	1Ckk	RETL k	$k \rightarrow A$, [Top of Stack] $\rightarrow PC$	None
1 1101 kkkk kkkk	1Dkk	SUB A,k	$k-A \rightarrow A$	Z, C, DC
1 1110 0000 0001	1E01	INT	$PC+1 \rightarrow [SP]$, 001H $\rightarrow PC$	None
1 1111 kkkk kkkk	1Fkk	ADD A,k	$k+A \rightarrow A$	Z, C, DC
1 1110 11rr rrrr	1Err	TBRD R	If R8 Bit 7=0, Machine code (7:0) $\rightarrow R$ Else machine code (12:8) $\rightarrow R$	None

Note: ¹ This instruction is applicable to IOC5~IOCF only.

² This instruction is not recommended for RF operation.

³ This instruction cannot operate under RF.

6 Absolute Maximum Ratings

Items	Rating		
Temperature under bias	-40°C	to	85°C
Storage temperature	-65°C	to	150°C
Input voltage	-0.3V	to	+ 6.0V
Output voltage	-0.3V	to	+ 6.0V
Working Voltage	2.5V	to	5.5V
Working Frequency	DC	to	20 MHz

7 Electrical Characteristics

7.1 DC Electrical Characteristics

Ta= 25°C, VDD= 5.0V ± 5%, VSS= 0V

Symbol	Parameter	Condition	Min.	Typ.	Max.	Unit
Fxt	Crystal: VDD to 2.3V	Two cycles with two clocks	DC	–	4.0	MHz
Fxt	Crystal: VDD to 3V	Two cycles with two clocks	DC	–	8.0	MHz
Fxt	Crystal: VDD to 5V	Two cycles with two clocks	DC	–	20.0	MHz
ERC	RC: VDD to 5V	R: 5 KΩ, C: 39 pF	F-30%	1500	F+30%	kHz
IIL	Input Leakage Current for input pins	VIN = VDD, VSS	–	–	±1	μA
VIH1	Input High Voltage (Schmitt Trigger)	Ports 5, 6	0.7Vdd	–	Vdd+0.3V	V
VIL1	Input Low Voltage (Schmitt Trigger)	Ports 5, 6	-0.3V	–	0.3Vdd	V
VIHT1	Input High Threshold Voltage (VDD=5.0V)	/RESET, TCC (Schmitt Trigger)	0.7Vdd	–	Vdd+0.3V	V
VILT1	Input Low Threshold Voltage (VDD=5.0V)	/RESET, TCC (Schmitt Trigger)	-0.3V	–	0.3Vdd	V
VIHX1	Clock Input High Voltage (VDD=5.0V)	OSCI	2.9	3.0	3.1	V
VILX1	Clock Input Low Voltage (VDD=5.0V)	OSCI	1.7	1.8	1.9	V
VIHT2	Input High Threshold Voltage (VDD=3.0V)	/RESET, TCC (Schmitt Trigger)	0.7Vdd	–	Vdd+0.3V	V
VILT2	Input Low Threshold Voltage (VDD=3.0V)	/RESET, TCC (Schmitt Trigger)	-0.3V	–	0.3Vdd	V
IOH1	Output High Voltage (P50, P55, Port 6)	VOH = 0.9VDD	-9	-12	–	mA
	Output High Voltage (P51~P54)		-6.5	-8	–	
IOL1	Output Low Voltage (Ports 5, 6)	VOL = 0.1VDD	22	28	–	mA
LVR1	Low voltage reset level	Ta= 25°C	2.11	2.4	2.69	V
		Ta= -40~85°C	1.84	2.4	2.95	V
LVR2	Low voltage reset level	Ta= 25°C	2.9	3.3	3.72	V
		Ta= -40~85°C	2.53	3.3	4.05	V
LVR3	Low voltage reset level	Ta= 25°C	3.56	4.0	4.43	V
		Ta= -40~85°C	3.16	4.0	4.81	V

Symbol	Parameter	Condition	Min.	Typ.	Max.	Unit
IPH	Pull-high current	Pull-high active, input pin at VSS	-70	-75	-80	μA
IPL	Pull-low current	Pull-low active, input pin at V _{dd}	35	40	45	μA
ISB1	Power down current	All input and I/O pins at VDD, Output pin floating, WDT disabled	0.6	2.0	2.5	μA
ISB2	Power down current	All input and I/O pins at VDD, Output pin floating, WDT enabled	6	7	8	μA
ICC1	Operating supply current at two clocks	/RESET= 'High', Fosc=32kHz (Crystal type, CLKS="0") Output pin floating, WDT enabled	25	27	29	μA
ICC2	Operating supply current at two clocks	/RESET= 'High', Fosc=4MHz (IRC type, CLKS="0"), Output pin floating, WDT enabled	1.2	1.4	1.6	mA
ICC3	Operating supply current at two clocks	/RESET= 'High', Fosc = 4 MHz (Crystal type, CLKS="0"), Output pin floating, WDT enabled	2.4	2.6	3	mA
ICC4	Operating supply current at two clocks	/RESET= 'High', Fosc = 10 MHz (Crystal type, CLKS="0"), Output pin floating, WDT enabled	2.4	2.6	3	mA

Internal RC Electrical Characteristics (Ta=25°C, VDD=5V, VSS=0V)

Internal RC	Drift Rate				
	Temperature	Voltage	Min.	Typ.	Max.
4 MHz	25°C	5V	3.88 MHz	4 MHz	4.12 MHz
8 MHz	25°C	5V	7.76 MHz	8 MHz	8.24 MHz
16 MHz	25°C	5V	15.52 MHz	16 MHz	16.48 MHz
455kHz	25°C	5V	441.3kHz	455kHz	468.7kHz

Internal RC Electrical Characteristics (Ta=-40 ~85°C, VDD=2.2~5.5 V, VSS=0V)

Internal RC	Drift Rate				
	Temperature	Voltage	Min.	Typ.	Max.
4 MHz	-40 ~85°C	2.2V~5.5V	3.48 MHz	4 MHz	4.52 MHz
8 MHz	-40 ~85°C	2.2V~5.5V	6.96 MHz	8 MHz	9.04 MHz
16 MHz	-40 ~85°C	2.2V~5.5V	13.92 MHz	16 MHz	18.08 MHz
455kHz	-40 ~85°C	2.2V~5.5V	395.85kHz	455kHz	514.15kHz

7.2 Comparator Characteristics

V_{dd} = 5.0V, V_{ss}=0V, T_a=-40 to 85°C

Symbol	Parameter	Condition	Min.	Typ.	Max.	Unit
SR	Slew rate	–	0.1	0.2	–	V/μs
V _{os}	Input offset voltage	R _L =5.1K, (Note 1)	1	10	15	mV
IVR	Input voltage range	V _{dd} =5.0V, V _{ss} = 0.0V	0.5	–	4.5	V
OVS	Output voltage swing	V _d =5.0V, V _{ss} = 0.0V, R _L =10 KΩ	0	0.2	0.3	V
			4.7	4.8	5	
I _{co}	Supply current of Comparator	–	–	300	–	μA
V _s	Operating range	–	2.5	–	5.5	V

Note: 1. These parameters are hypothetical (not tested), provided here for design reference use only.

2. These parameters are subject to change without prior notice.

7.3 AC Electrical Characteristics

Ta=-40°C ~ 85°C, VDD=5V±5%, VSS=0V

Symbol	Parameter	Conditions	Min	Typ	Max	Unit
Dclk	Input CLK duty cycle	–	45	50	55	%
Tins	Instruction cycle time (CLKS="0")	Crystal type	100	–	DC	ns
		RC type	500	–	DC	ns
Ttcc	TCC input period	–	(Tins+20)/N*	–	–	ns
Tdrh	Device reset hold time	Ta = 25°C TXAL, SUT1, SUT0=1,1	17.6-30%	17.6	17.6+30%	ms
Trst	/RESET pulse width	Ta = 25°C	2000	–	–	ns
Twdt1*	Watchdog timer period	Ta = 25°C SUT0=1	17.6-30%	17.6	17.6+30%	ms
Twdt2*	Watchdog timer period	Ta = 25°C SUT0=0	4.5-30%	4.5	4.5+30%	ms
Tset	Input pin setup time	–	–	0	–	ns
Thold	Input pin hold time	–	–	20	–	ns
Tdelay	Output pin delay time	Cload=20pF	–	50	–	ns

Note: 1. N = selected prescaler ratio

2. Twdt1: The Option Word 1 (SUT1, SUT0) is used to define the oscillator set-up time. In Crystal mode, the WDT timeout length is the same as the set-up time (18ms).
3. Twdt2: The Option Word 1 (SUT1, SUT0) is used to define the oscillator set-up time. In Crystal mode, the WDT timeout length is the same as set-up time (4.5ms).
4. These parameters are hypothetical (not tested) and are provided for design reference only.
5. Data under Minimum, Typical, and Maximum (Min, Typ, and Max) columns are based on hypothetical results at 25°C. These data are for design reference use only.
6. The Watchdog timer duration is determined by Code Option Word 1 (Bit 6, Bit 5).

7.4 Device Characteristics

The graphs provided in the following pages were derived based on a limited number of samples and are shown here for reference only. The device characteristics illustrated herein are not guaranteed for its accuracy. In some graphs, the data may be out of the specified warranted operating range.

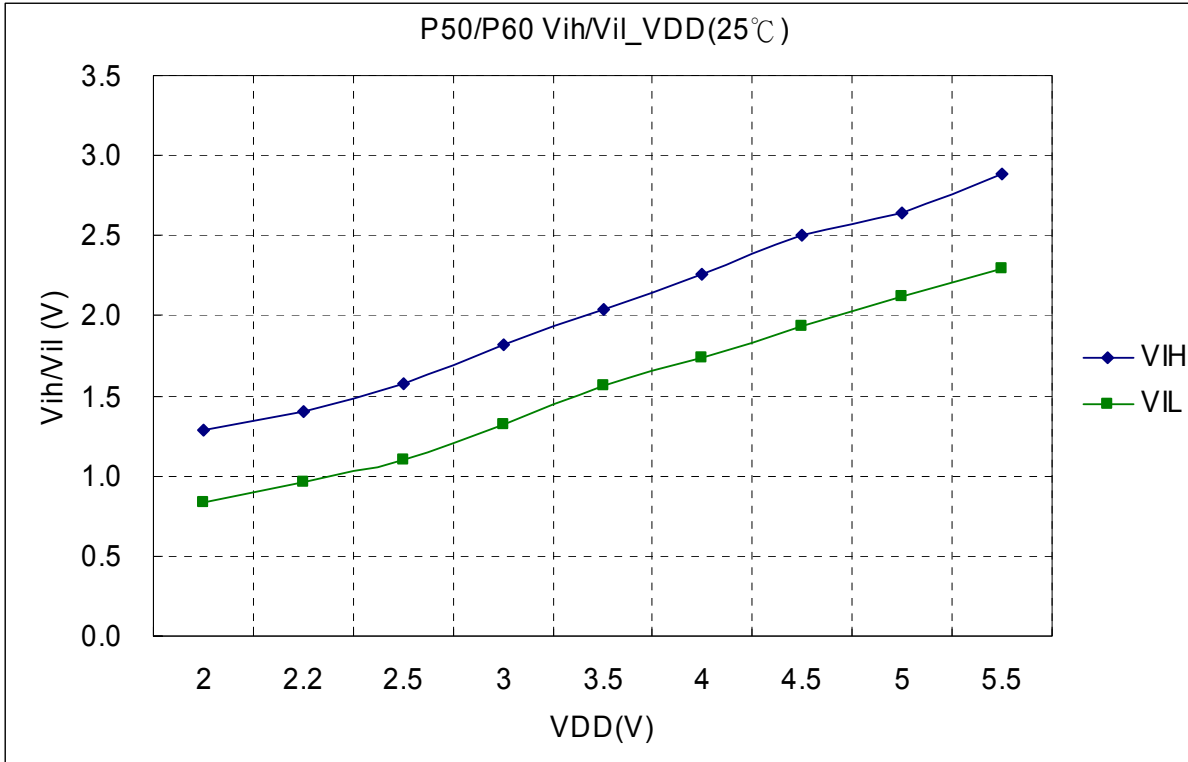

Figure 7-1 Vih, Vil vs. VDD (25°C)

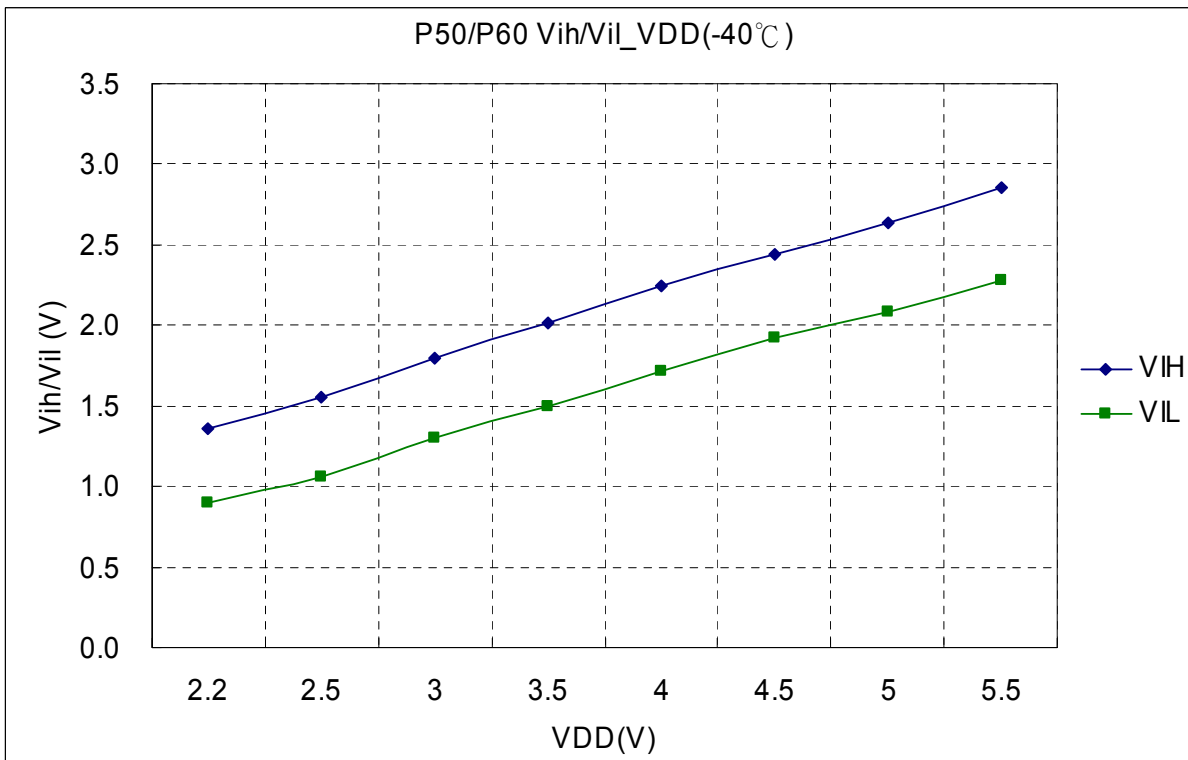

Figure 7-2 Vih, Vil vs. VDD (-40 °C)

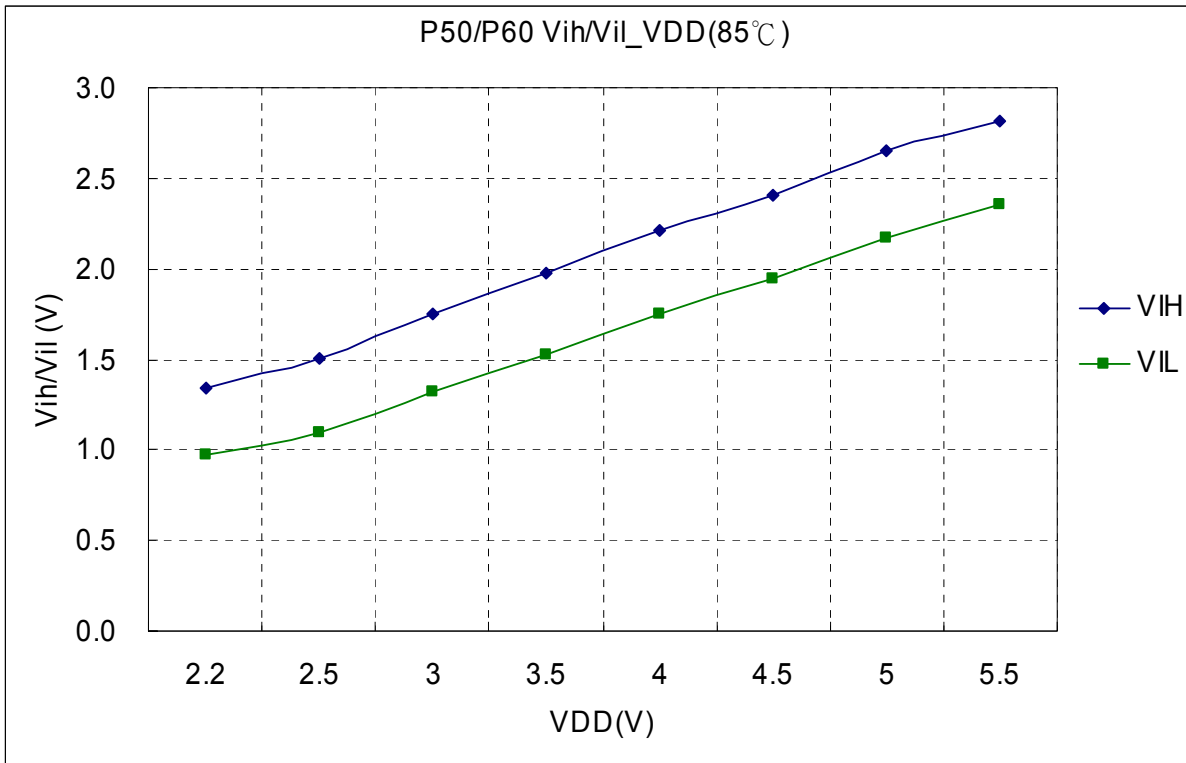

Figure 7-3 Vih, Vil vs. VDD (85°C)

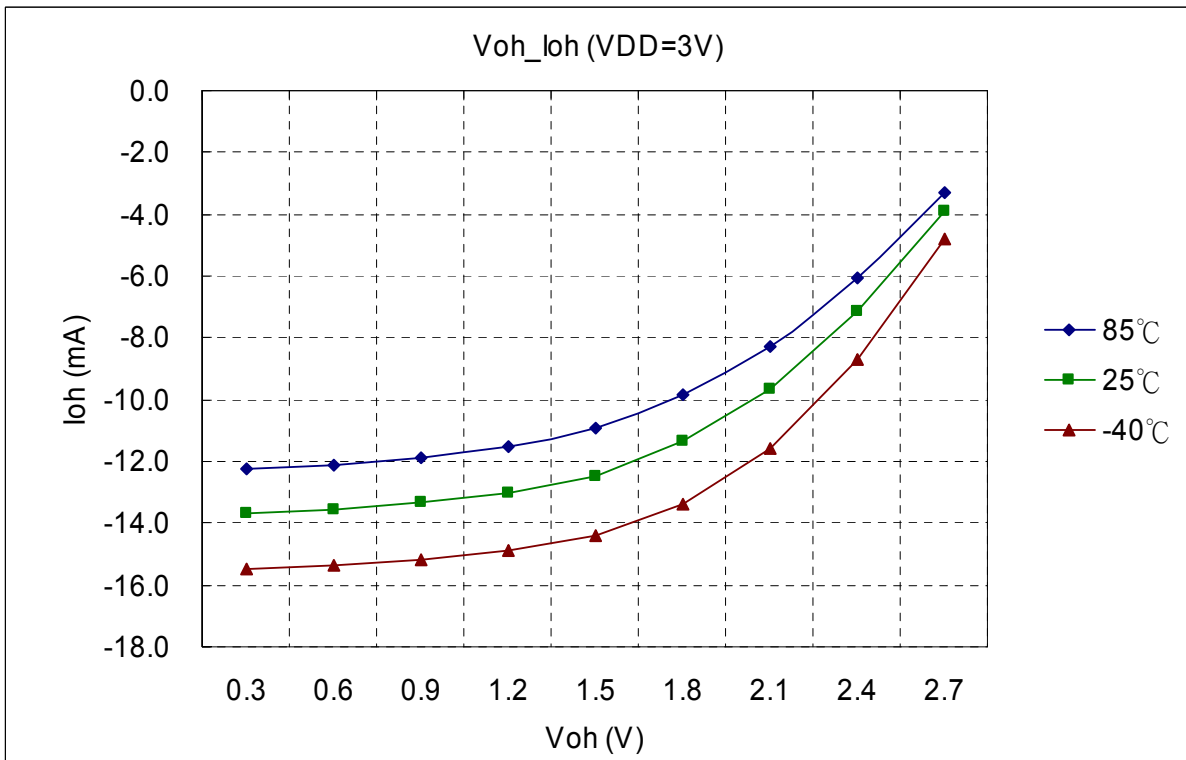

Figure 7-4 Voh vs. loh at VDD=3V

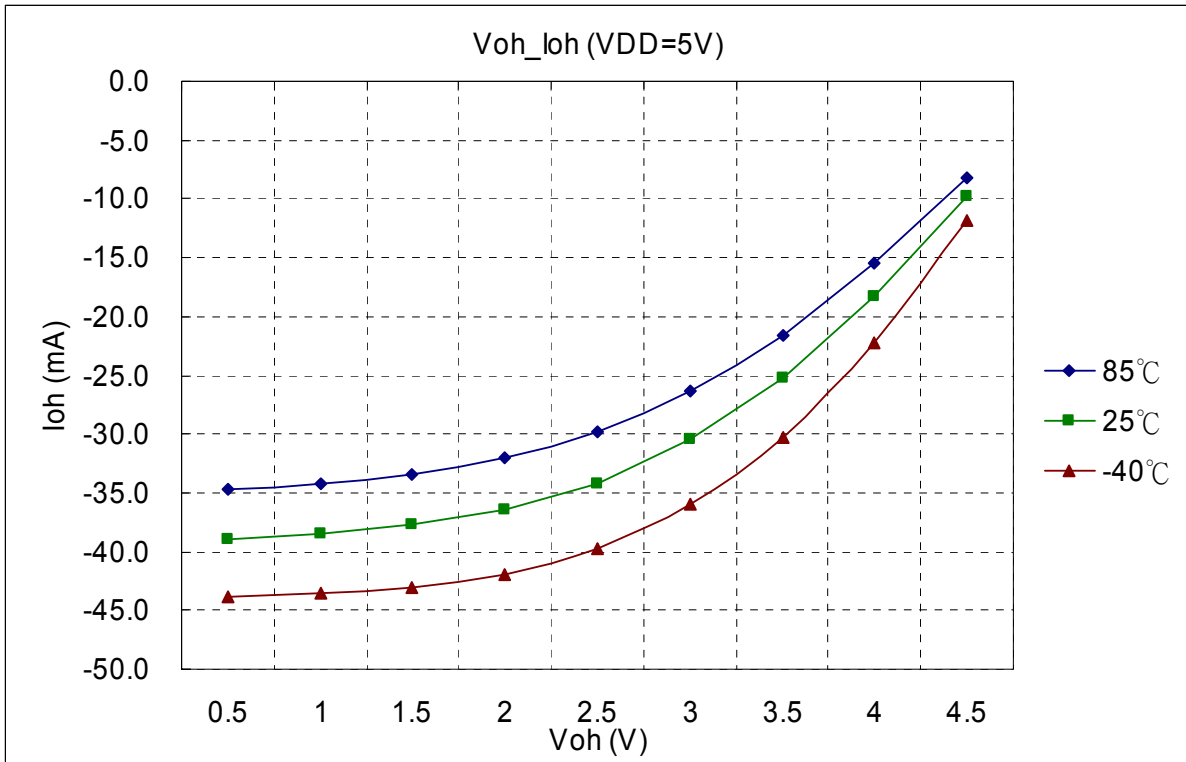

Figure 7-5 Voh vs. Ioh at VDD=5V

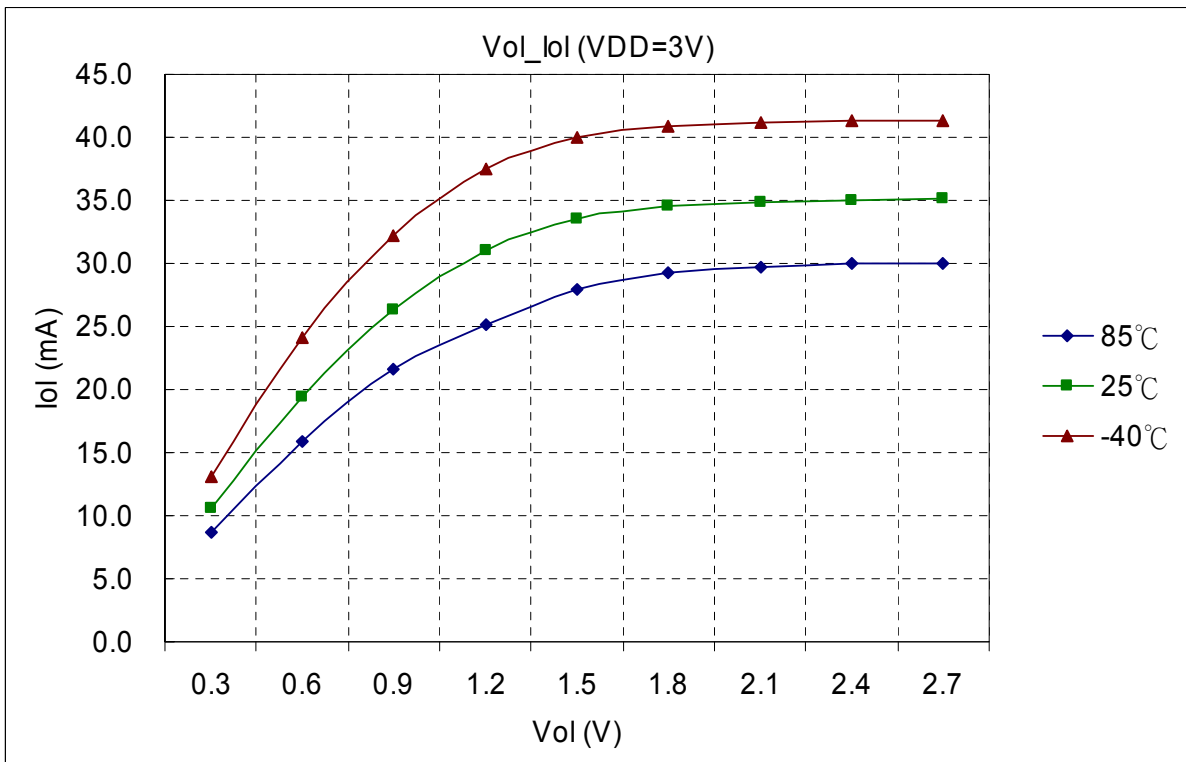

Figure 7-6 Vol vs. Iol at VDD=3V

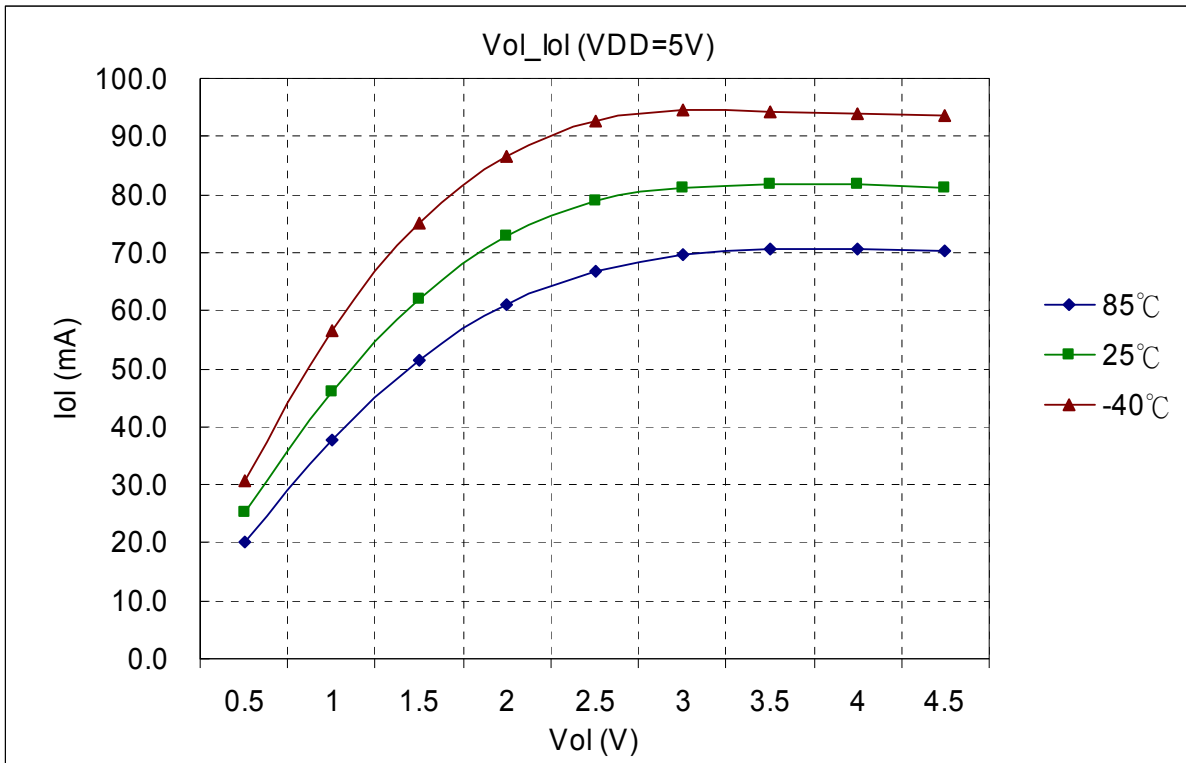

Figure 7-7 Vol vs. Iol at VDD=5V

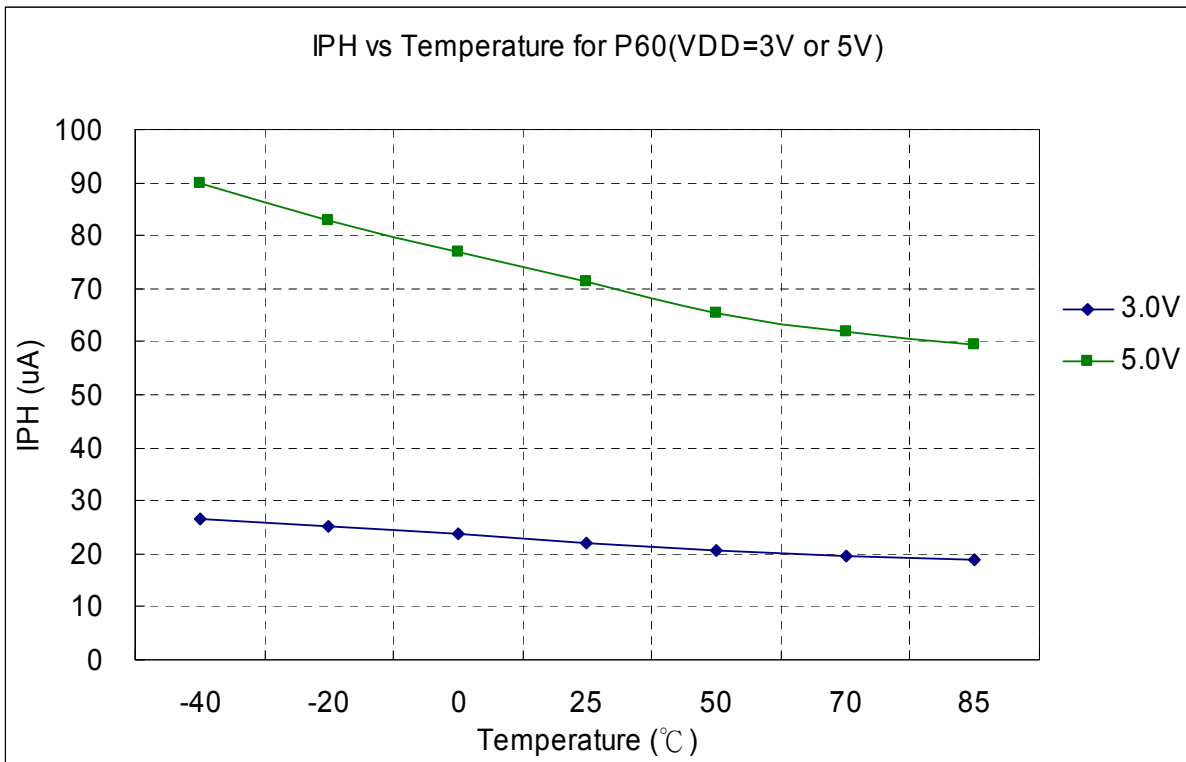

Figure 7-8 IPH vs. Temperature

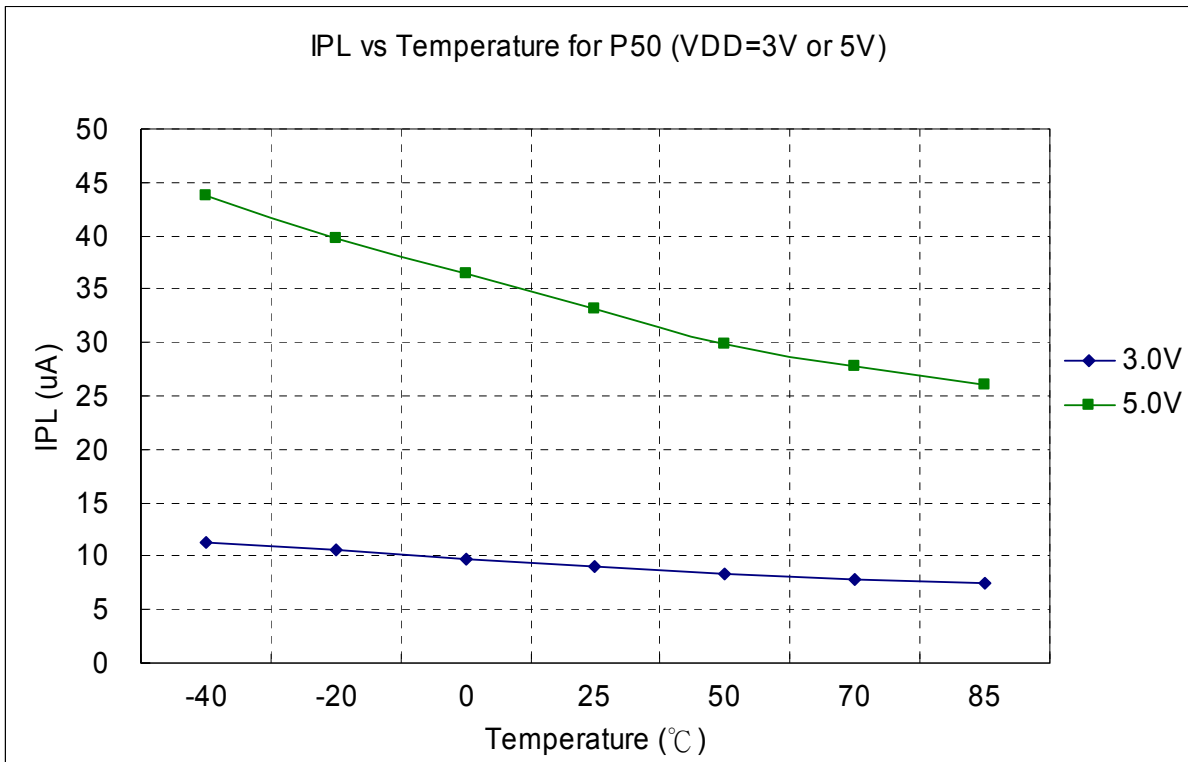

Figure 7-9 IPL vs. Temperature

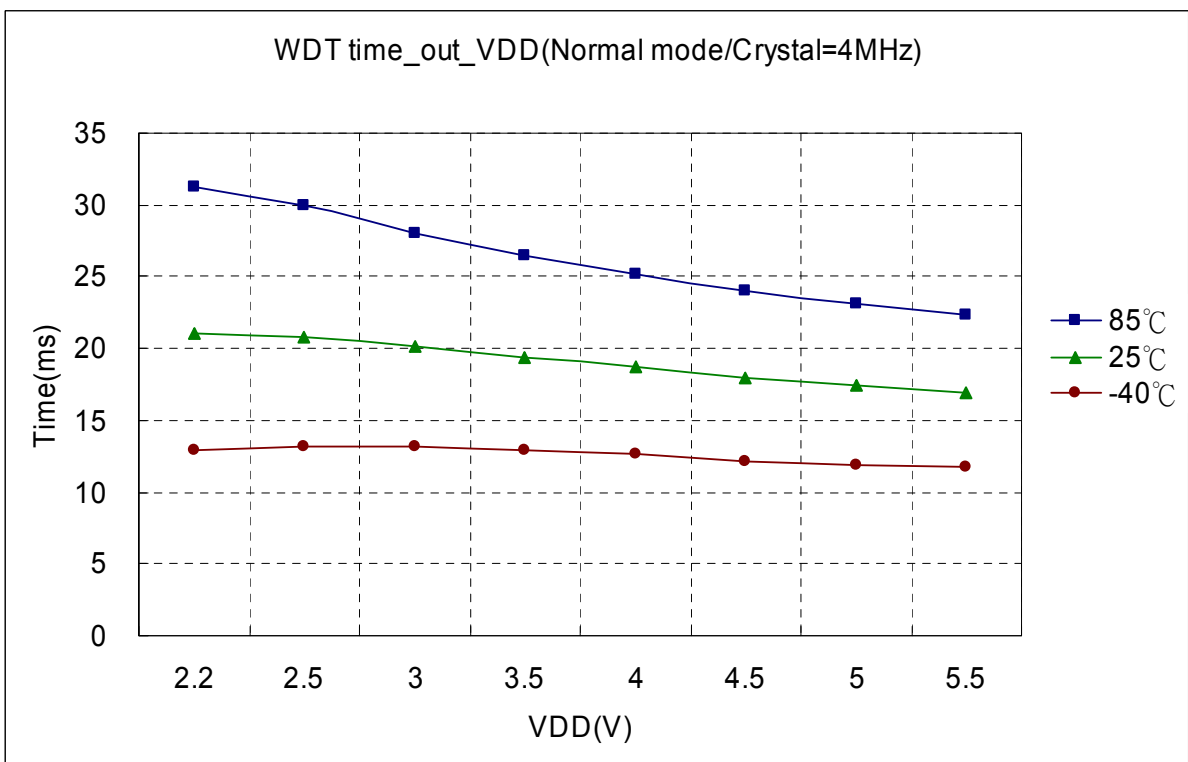

Figure 7-10 WDT time out vs. VDD, with prescaler set to 1:1

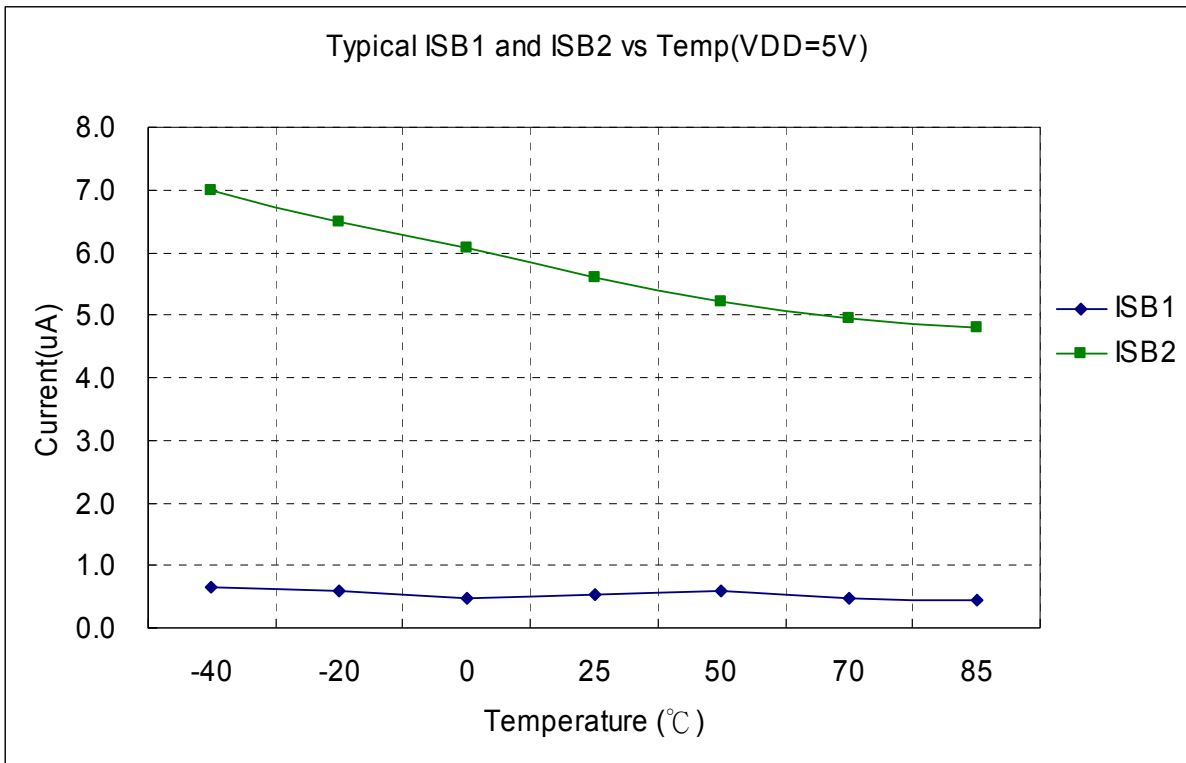

Figure 7-11 Typical Standby Current (VDD=5V) vs. Temperature

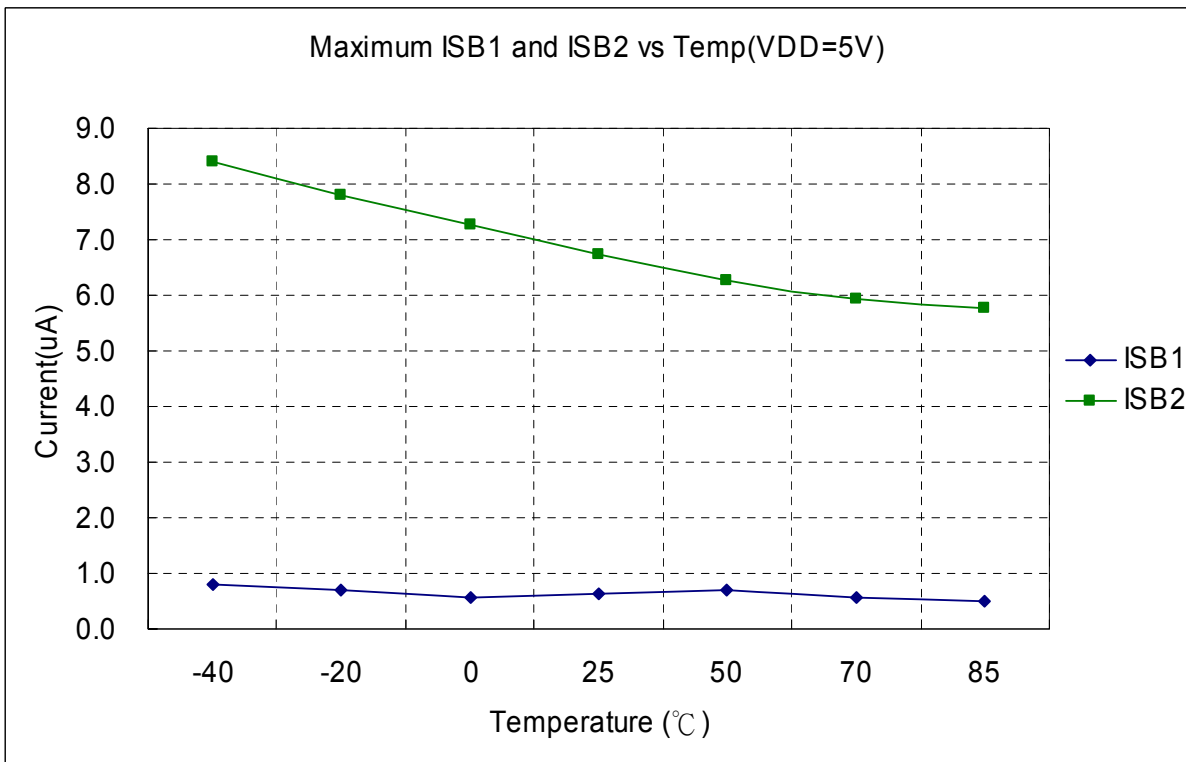

Figure 7-12 Maximum Standby Current (VDD=5V) vs. Temperature

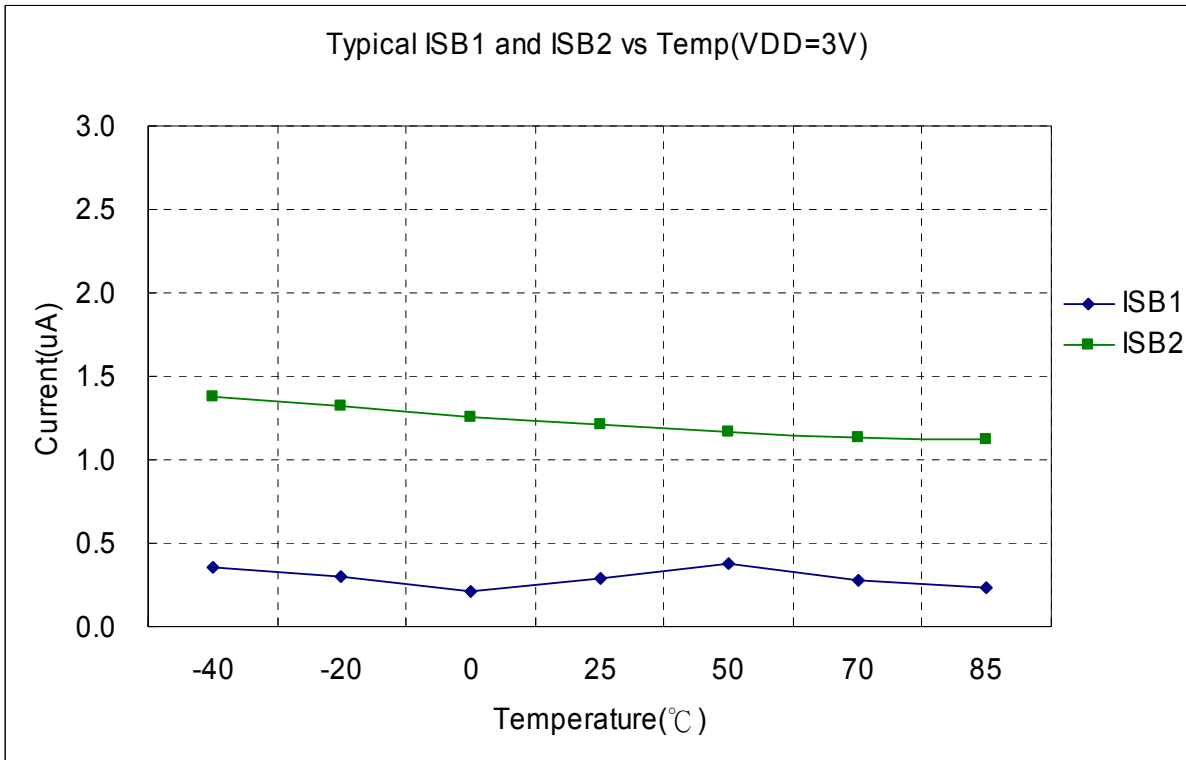

Figure 7-13 Typical Standby Current (VDD=3V) vs. Temperature

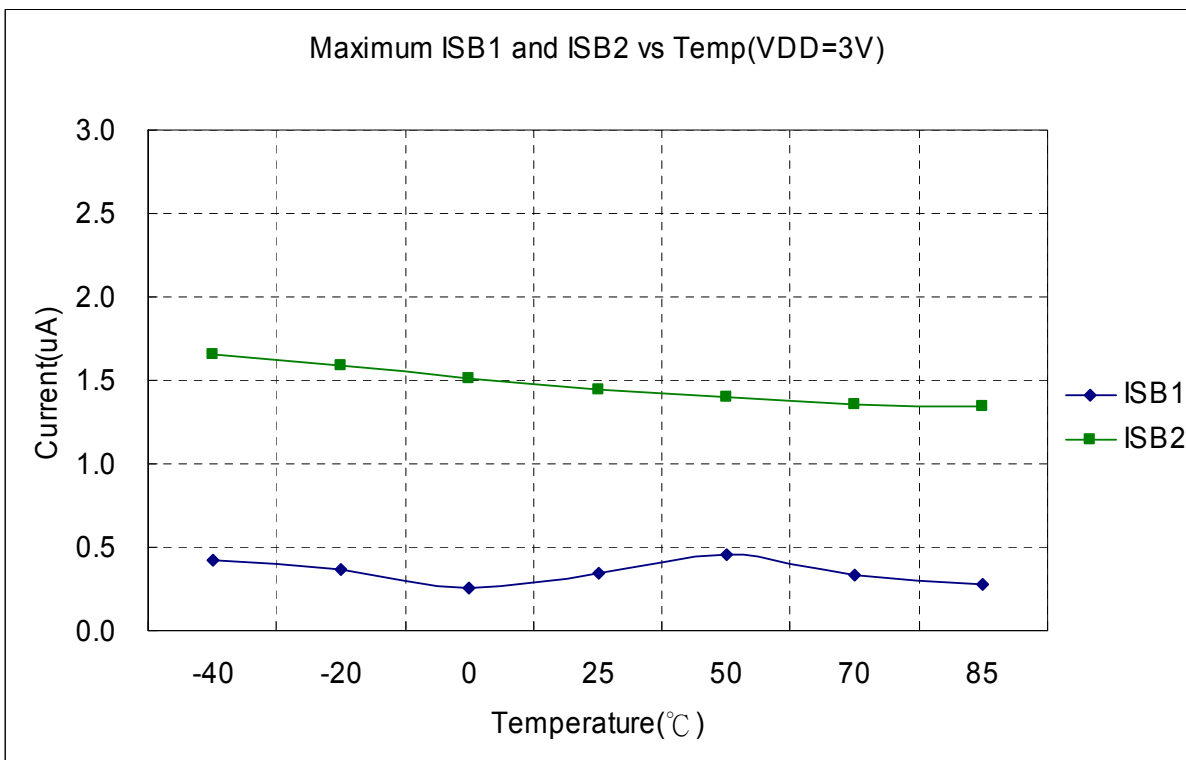

Figure 7-14 Maximum Standby Current (VDD=3V) vs. Temperature

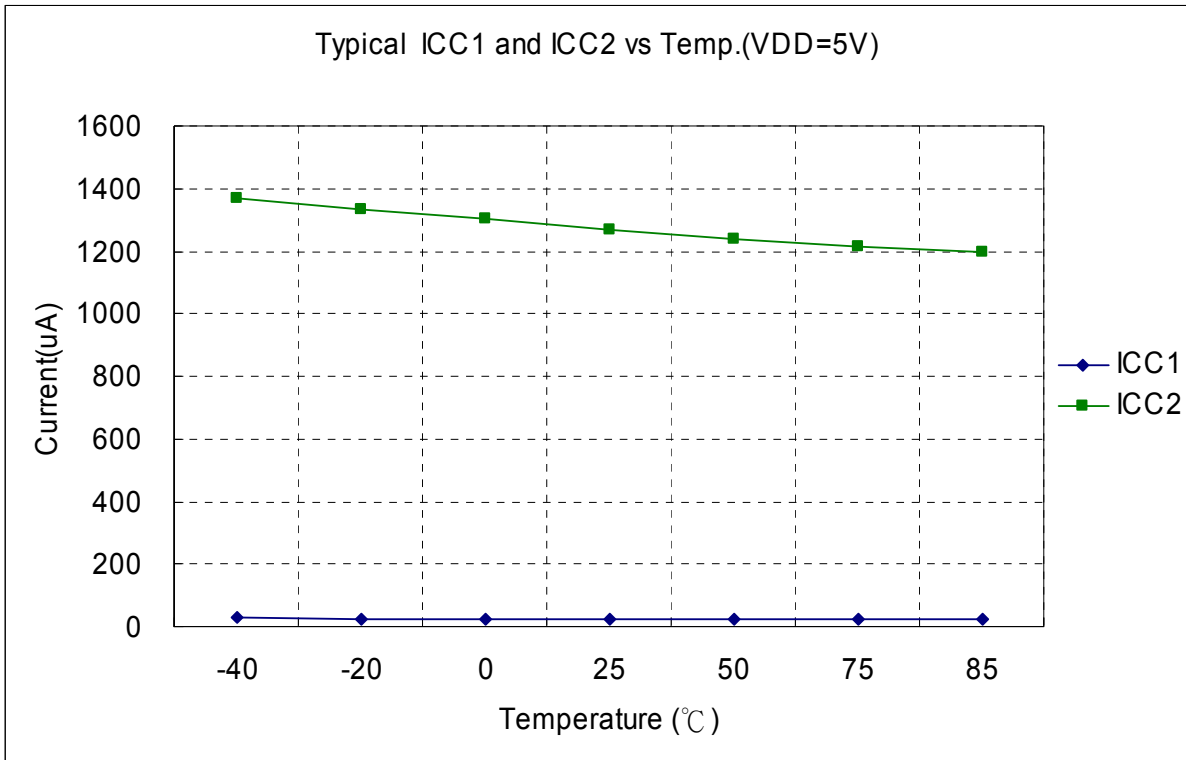

Figure 7-15 Typical Operating Current (VDD=5V) vs. Temperature

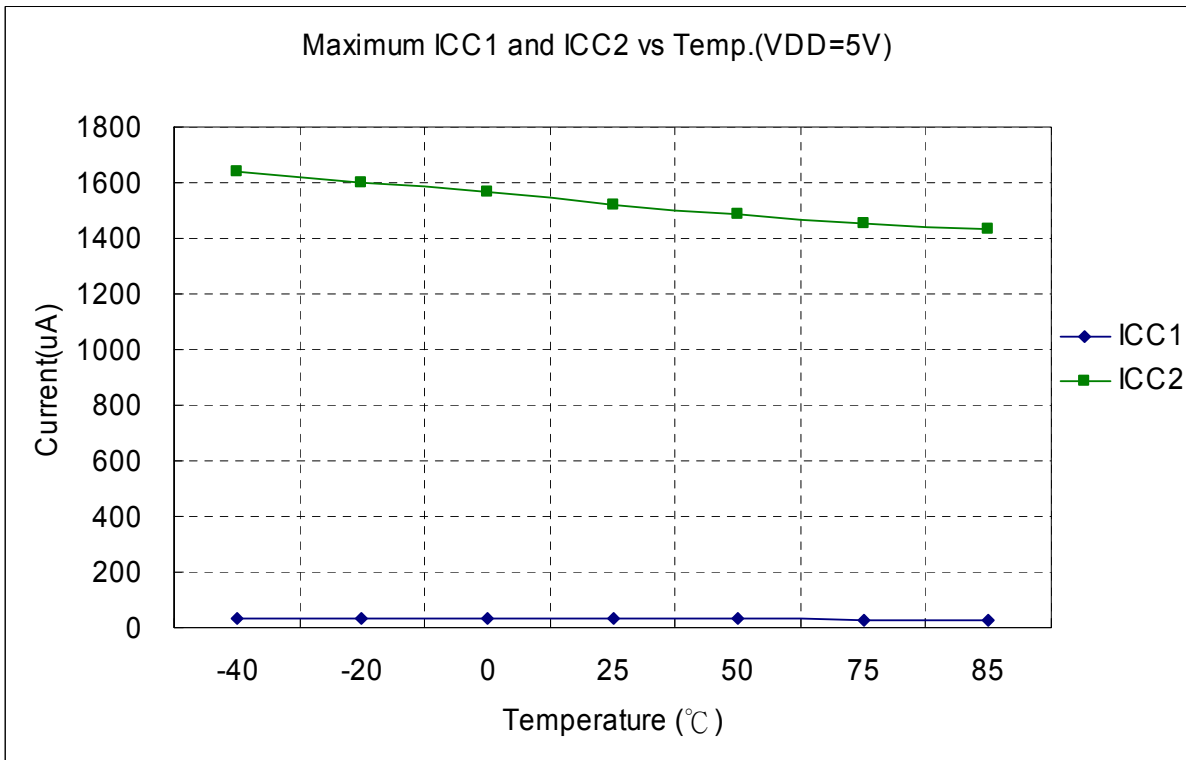

Figure 7-16 Maximum Operating Current (VDD=5V) vs. Temperature

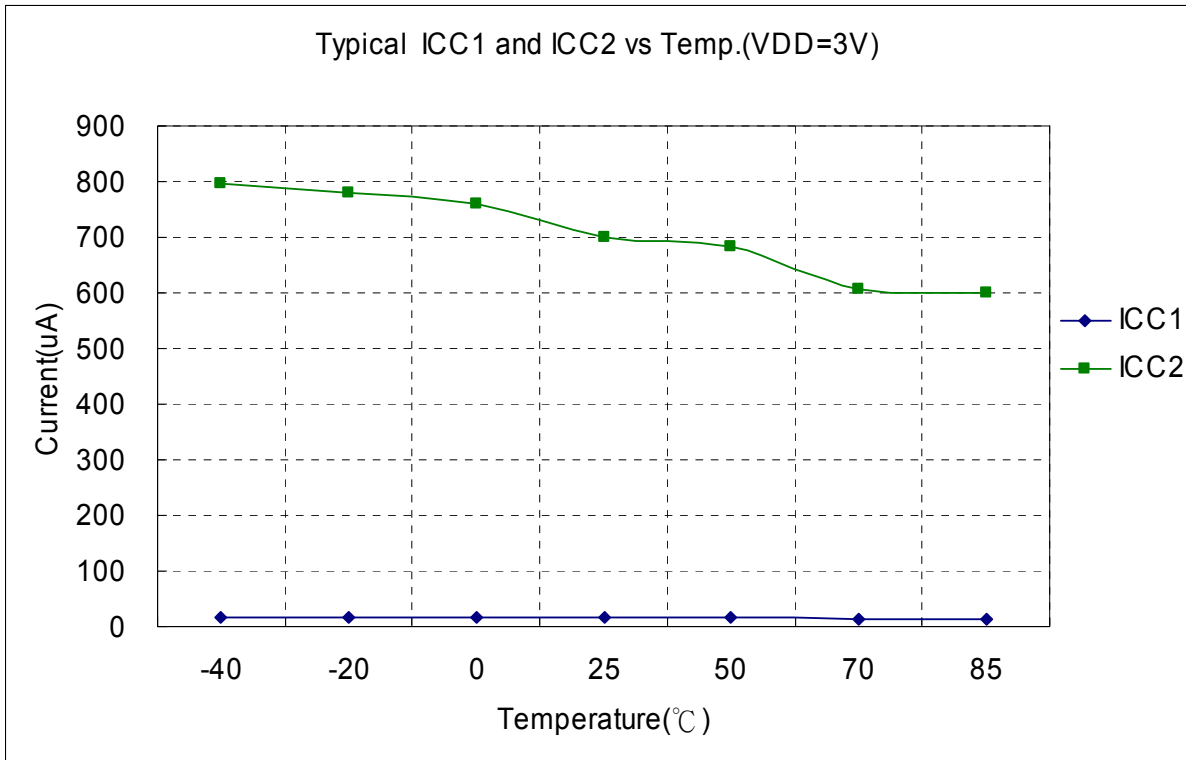

Figure 7-17 Typical Operating Current (VDD=3V) vs. Temperature

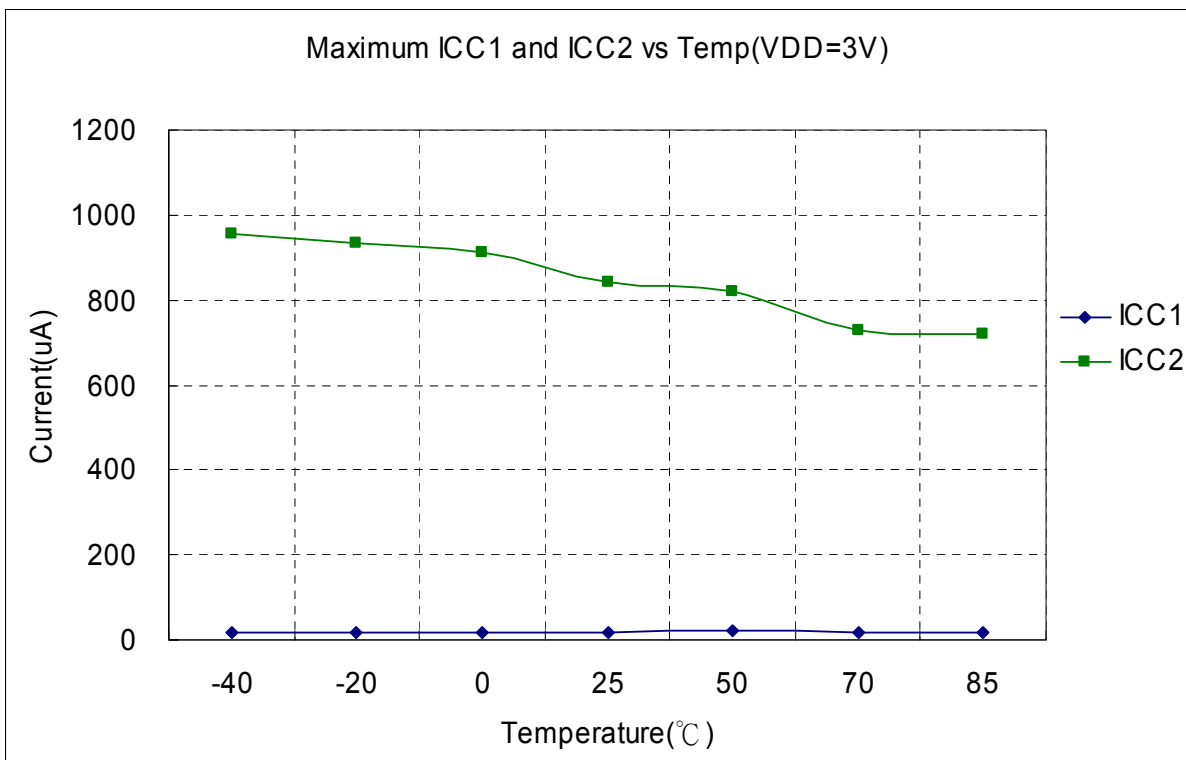

Figure 7-18 Maximum Operating Current (VDD=3V) vs. Temperature

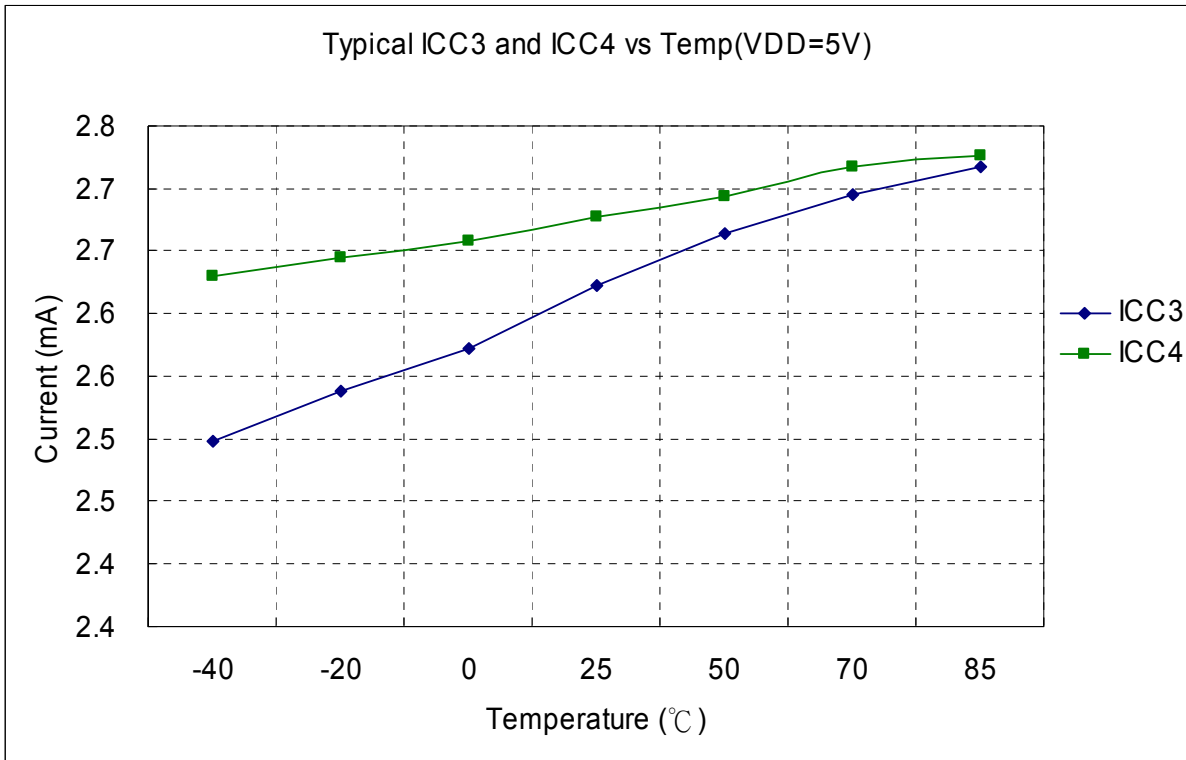

Figure 7-19 Typical Operating Current (VDD=5V) vs. Temperature

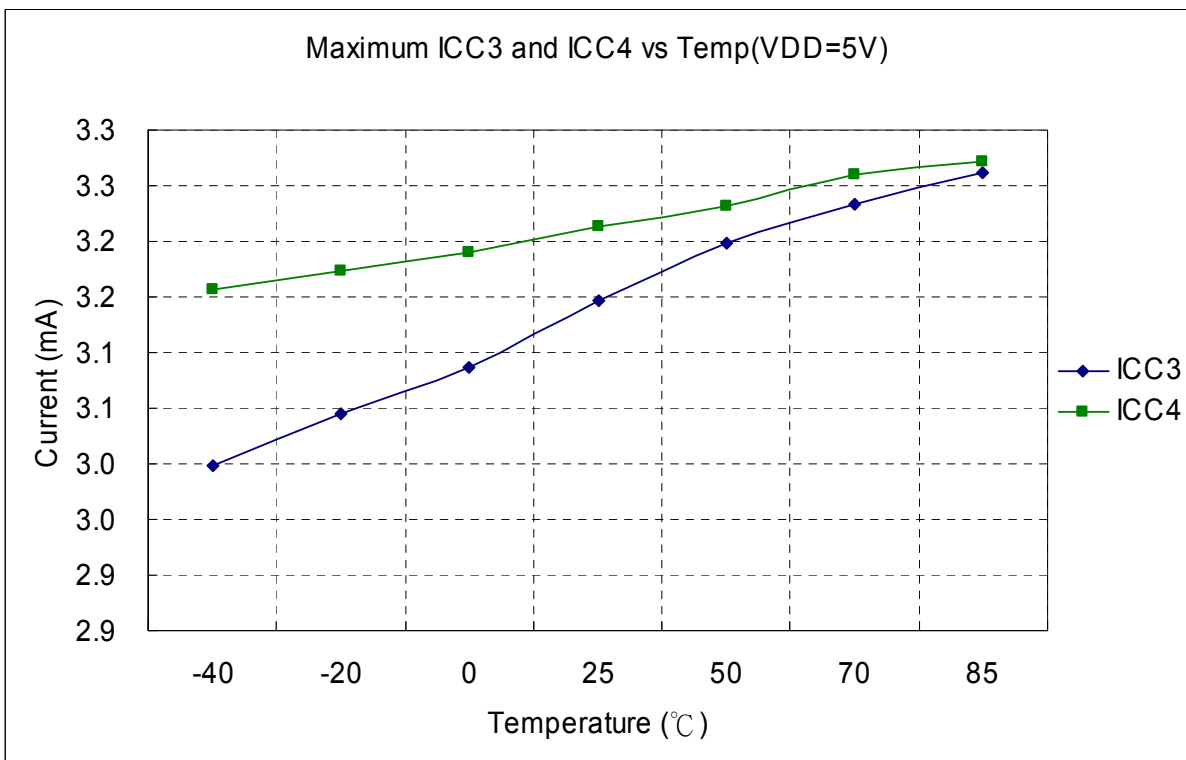

Figure 7-20 Maximum Operating Current (VDD=5V) vs. Temperature

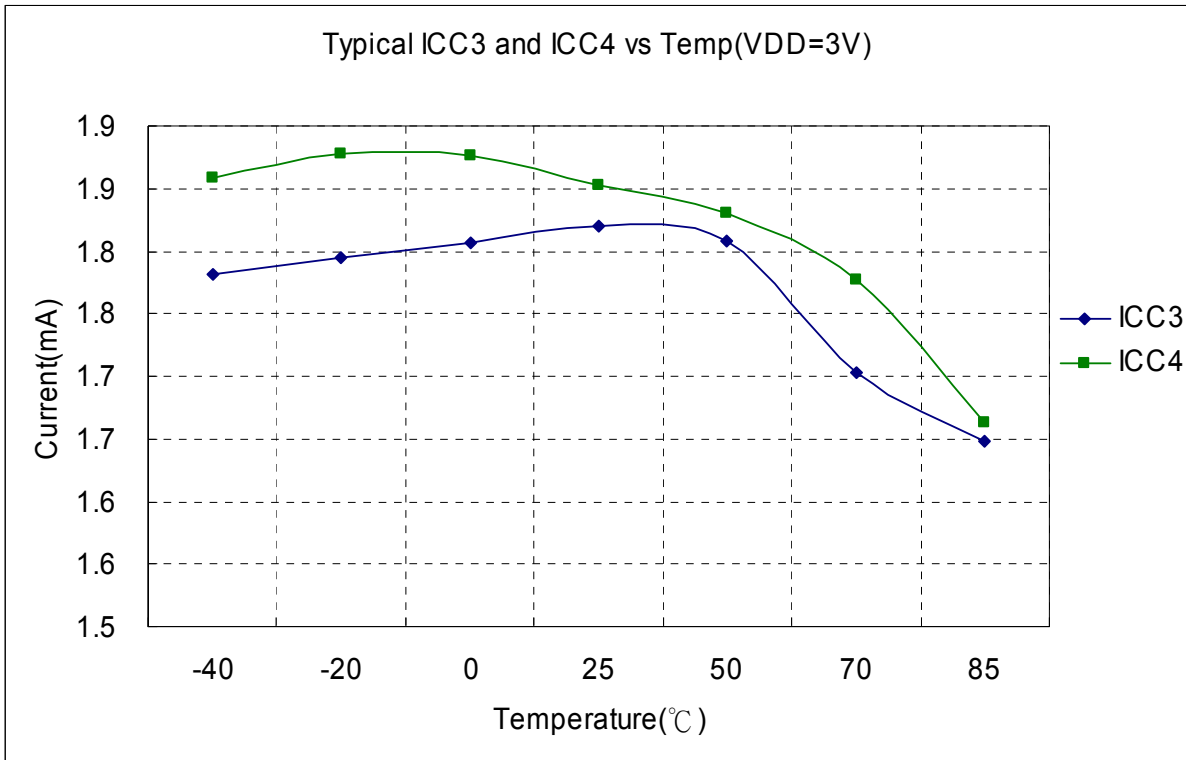

Figure 7-21 Typical Operating Current (VDD=3V) vs. Temperature

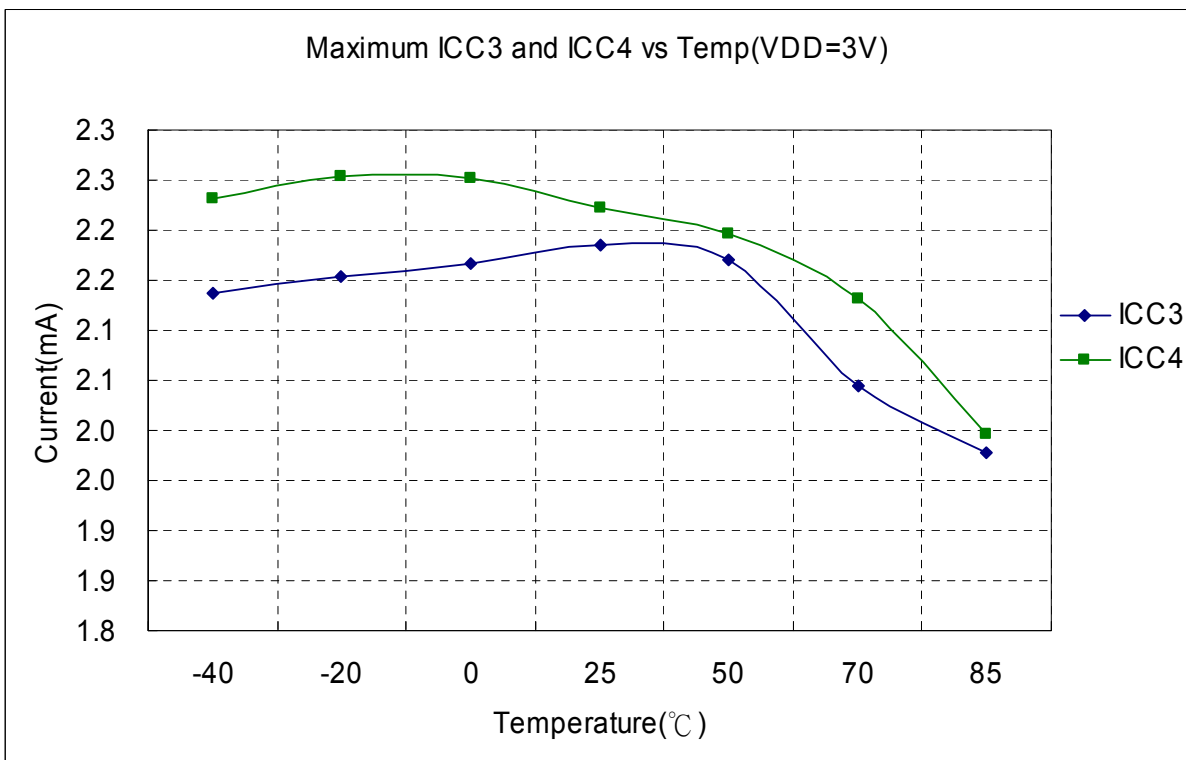
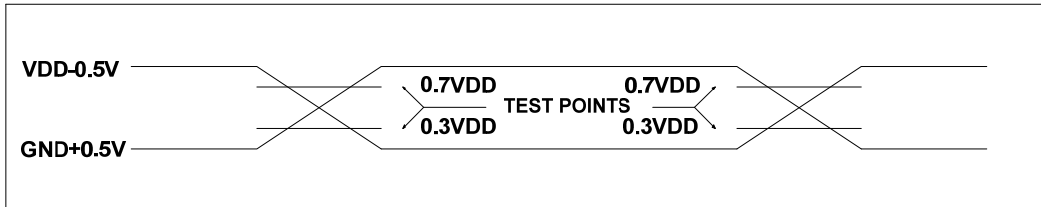

Figure 7-22 Maximum Operating Current (VDD=3V) vs. Temperature

8 Timing Diagram

AC Test Input/Output Waveform



AC Testing: Input is driven at VDD-0.5V for logic "1" and GND+0.5V for logic "0". Timing measurements are made at 0.7VDD for logic "1" and 0.3VDD for logic "0"

RESET Timing (CLK="0")

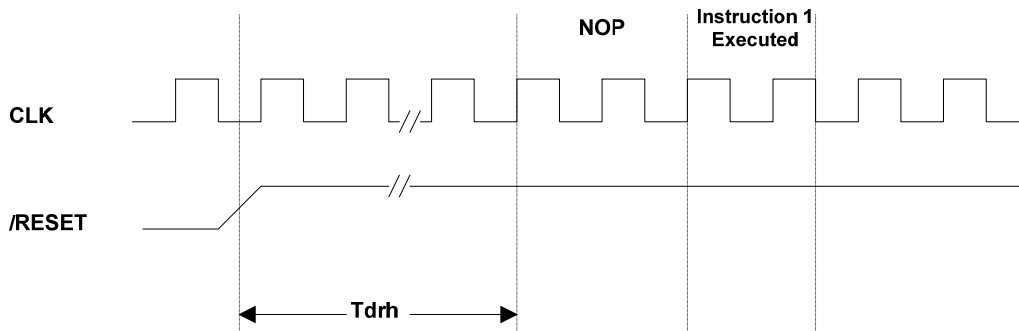

TCC Input Timing (CLKS="0")

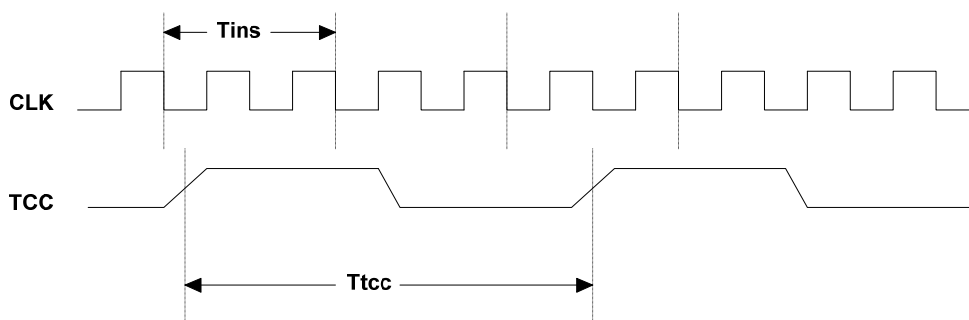

APPENDIX

A Package Type

OTP MCU	Package Type	Pin Count	Package Size
EM78P163ND14J	DIP	14	300 mil
EM78P163NSO14J	SOP	14	150 mil
EM78P163ND16J	DIP	16	300 mil
EM78P163NSO16AJ	SOP	16	150 mil

These are Green products which do not contain hazardous substances and comply with the third edition of Sony SS-00259 standard.

Pb content is less than 100ppm and complies with Sony specifications.

Part No.	EM78P163N/J
Electroplate type	Pure Tin
Ingredient (%)	Sn: 100%
Melting point (°C)	232°C
Electrical resistivity ($\mu\Omega$ -cm)	11.4
Hardness (hv)	8~10
Elongation (%)	>50%

B Package Information

- 14-Lead Plastic Dual in line (PDIP) — 300 mil

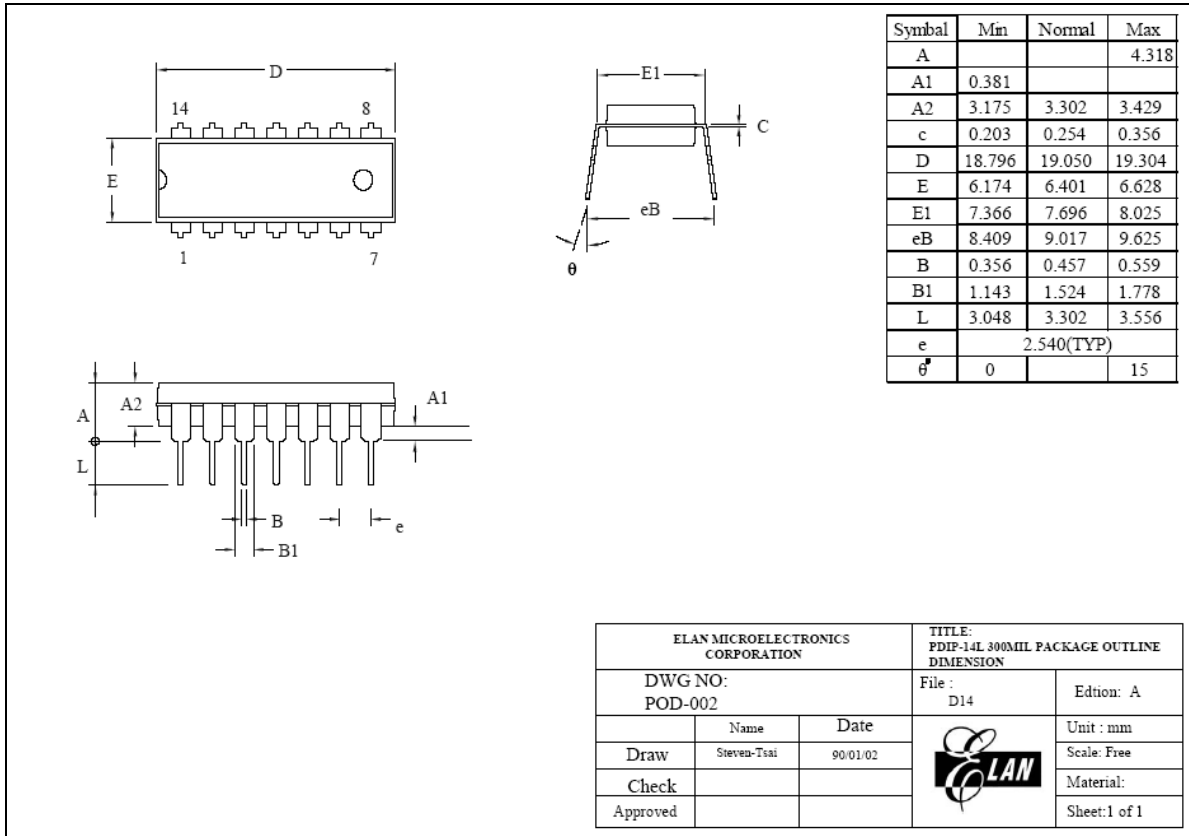

■ **14-Lead Plastic Small Outline (SOP) — 150 mil**

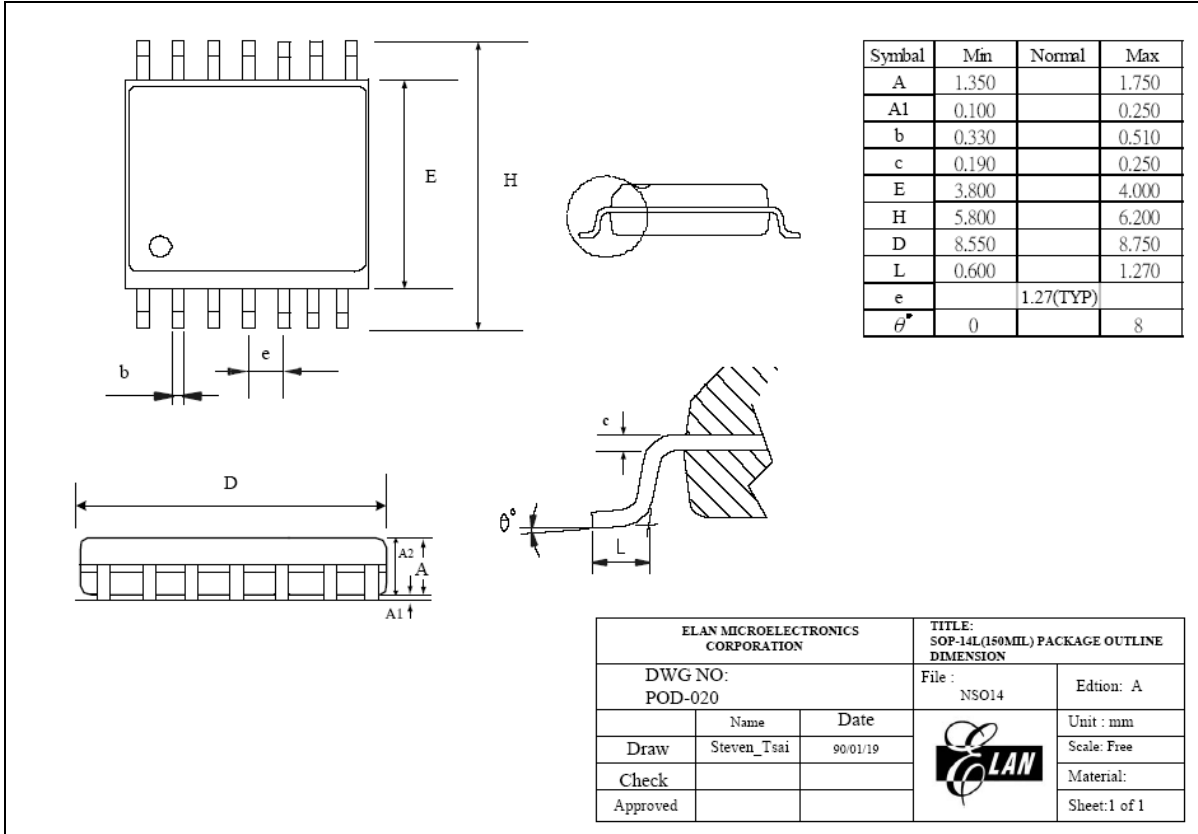

■ **16-Lead Plastic Dual in line (PDIP) — 300 mil**

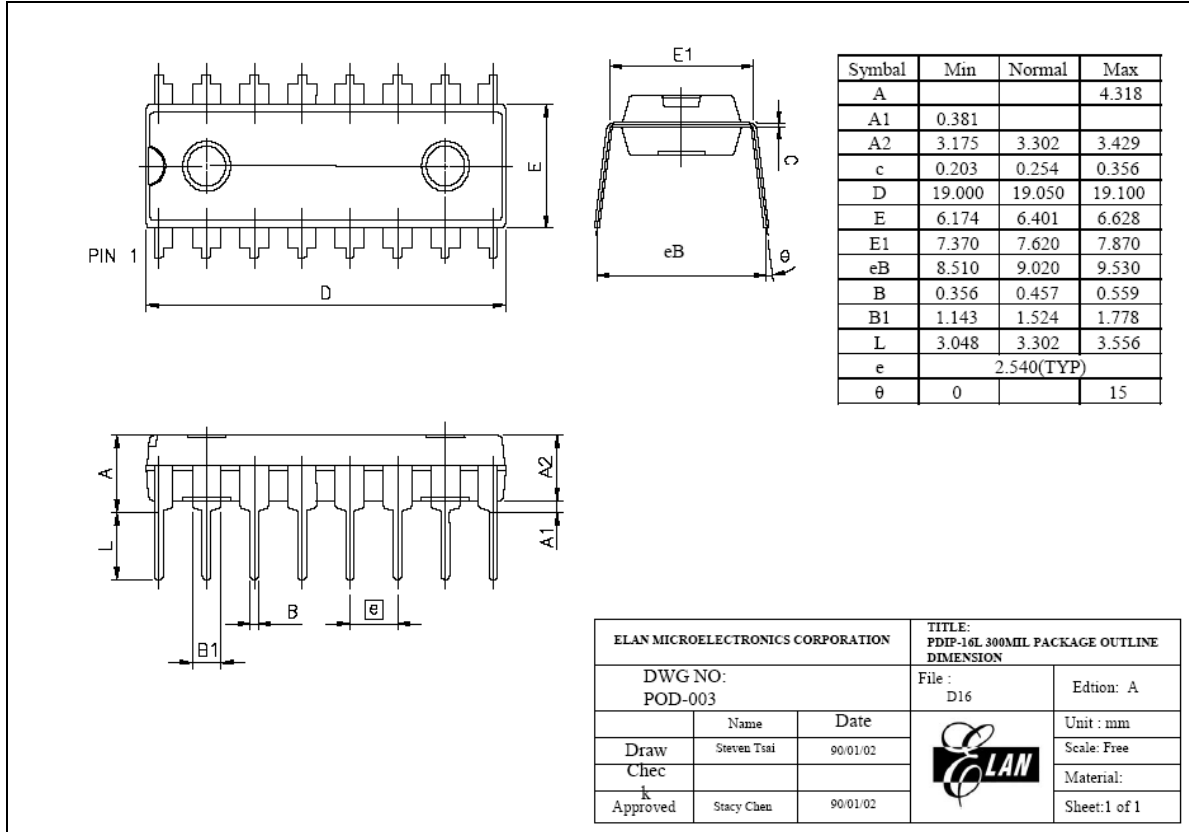

■ **16-Lead Plastic Small Outline (SOP) — 150 mil**

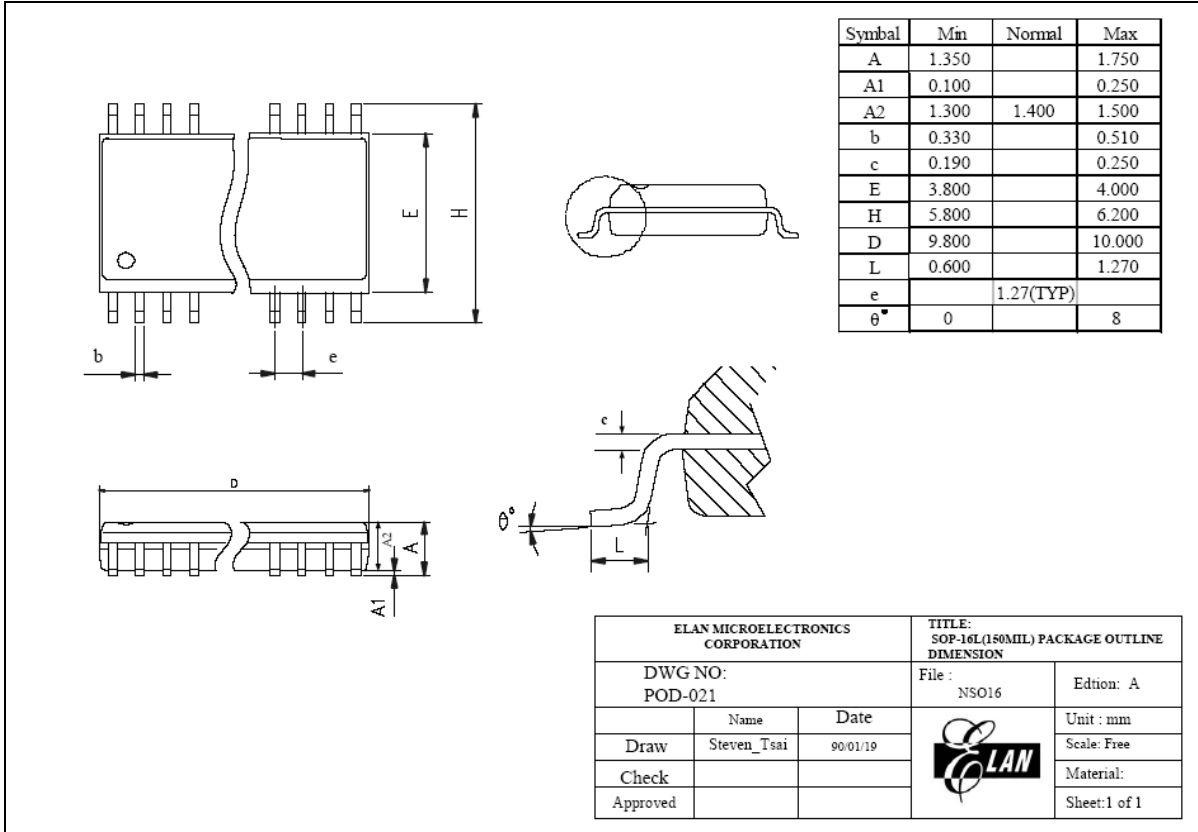

C Quality Assurance and Reliability

Test Category	Test Conditions	Remarks
Solderability	Solder temperature= $245 \pm 5^{\circ}\text{C}$, for 5 seconds up to the stopper using a rosin-type flux	-
Pre-condition	Step 1: TCT, 65°C (15 min)~ 150°C (15mins), 10 cycles	For SMD IC (such as SOP, QFP, SOJ, etc)
	Step 2: Bake at 125°C , TD (endurance)=24 hrs	
	Step 3: Soak at $30^{\circ}\text{C}/60\%$, TD (endurance)=192 hrs	
	Step 4: IR flow 3 cycles (Pkg thickness ≥ 2.5 mm or Pkg volume ≥ 350 mm ³ ---- $225 \pm 5^{\circ}\text{C}$) (Pkg thickness ≤ 2.5 mm or Pkg volume ≤ 350 mm ³ ---- $240 \pm 5^{\circ}\text{C}$)	
Temperature cycle test	-65°C (15mins)~ 150°C (15 min), 200 cycles	-
Pressure cooker test	TA = 121°C , RH=100%, pressure=2 atm, TD (endurance)= 96 hrs	-
High temperature / High humidity test	TA= 85°C , RH=85% , TD (endurance) = 168 , 500 hrs	-
High-temperature storage life	TA= 150°C , TD (endurance) = 500, 1000 hrs	-
High-temperature operating life	TA= 125°C , VCC = Max. operating voltage, TD (endurance) = 168, 500, 1000 hrs	-
Latch-up	TA= 25°C , VCC = Max. operating voltage, 150mA/20V	-
ESD (HBM)	TA= 25°C , $\geq \pm 3\text{KV} $	IP_ND,OP_ND,IO_ND IP_NS,OP_NS,IO_NS IP_PD,OP_PD,IO_PD, IP_PS,OP_PS,IO_PS, VDD-VSS(+),VDD_VSS (-) mode
ESD (MM)	TA= 25°C , $\geq \pm 300\text{V} $	

C.1 Address Trap Detect

An address trap detect is one of the MCU embedded fail-safe functions that detects MCU malfunction caused by noise or the like. Whenever the MCU attempts to fetch an instruction from a certain section of ROM, an internal recovery circuit is auto started. If a noise-caused address error is detected, the MCU will repeat execution of the program until the noise is eliminated. The MCU will then continue to execute the next program.

D Ordering and Manufacture Information

EM78P163NSO14J

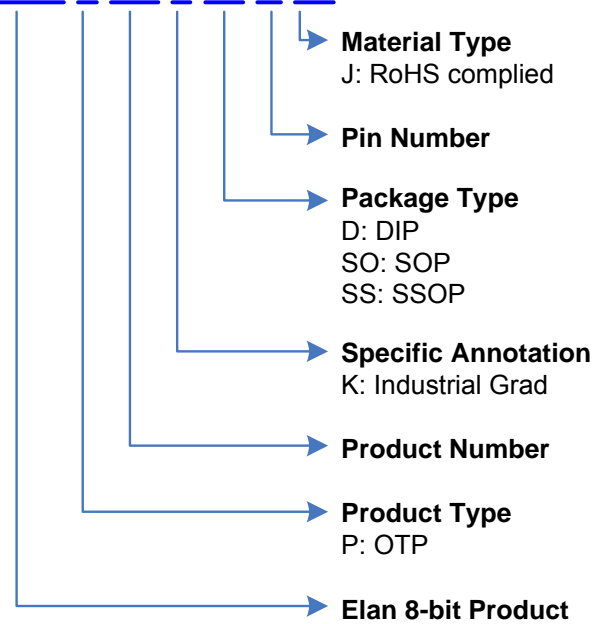

For example:

EM78P163NSO14J

is EM78P163N with OTP program memory, industrial grade product, in 14-pin SOP package with RoHS complied

