EM78F 648/644/642/641N
548/544/542/541N

**Flash Series 8-Bit
Microcontroller**

Product Specification

Doc. VERSION 1.2

ELAN MICROELECTRONICS CORP.

March 2013



Trademark Acknowledgments:

IBM is a registered trademark and PS/2 is a trademark of IBM.

Windows is a trademark of Microsoft Corporation.

ELAN and ELAN logo  are trademarks of ELAN Microelectronics Corporation.

Copyright © 2010~2013 by **ELAN Microelectronics Corporation**

All Rights Reserved

Printed in Taiwan

The contents of this specification are subject to change without further notice. ELAN Microelectronics assumes no responsibility concerning the accuracy, adequacy, or completeness of this specification. ELAN Microelectronics makes no commitment to update, or to keep current the information and material contained in this specification. Such information and material may change to conform to each confirmed order.

In no event shall ELAN Microelectronics be made responsible for any claims attributed to errors, omissions, or other inaccuracies in the information or material contained in this specification. ELAN Microelectronics shall not be liable for direct, indirect, special incidental, or consequential damages arising from the use of such information or material.

The software (if any) described in this specification is furnished under a license or nondisclosure agreement, and may be used or copied only in accordance with the terms of such agreement.

ELAN Microelectronics products are not intended for use in life support appliances, devices, or systems. Use of ELAN Microelectronics product in such applications is not supported and is prohibited.

NO PART OF THIS SPECIFICATION MAY BE REPRODUCED OR TRANSMITTED IN ANY FORM OR BY ANY MEANS WITHOUT THE EXPRESSED WRITTEN PERMISSION OF ELAN MICROELECTRONICS.



ELAN MICROELECTRONICS CORPORATION

Headquarters:

No. 12, Innovation 1st Road
Hsinchu Science Park
Hsinchu, TAIWAN 30076
Tel: +886 3 563-9977
Fax: +886 3 563-9966
webmaster@emc.com.tw
<http://www.emc.com.tw>

Hong Kong:

Elan (HK) Microelectronics Corporation, Ltd.
Flat A, 19F., World Tech Centre
95 How Ming Street, Kwun Tong
Kowloon, HONG KONG
Tel: +852 2723-3376
Fax: +852 2723-7780

USA:

Elan Information Technology Group (U.S.A.)
PO Box 601
Cupertino, CA 95015
U.S.A.
Tel: +1 408 366-8225
Fax: +1 408 366-8225

Korea:**Elan Korea Electronics Company, Ltd.**

301 Dong-A Building
632 Kojan-Dong, Namdong-ku
Incheon City, KOREA
Tel: +82 32 814-7730
Fax: +82 32 813-7730

Shenzhen:**Elan Microelectronics Shenzhen, Ltd.**

8A Floor, Microprofit Building
Gaoxin South Road 6
Shenzhen Hi-tech Industrial Park
South Area, Shenzhen
CHINA 518057
Tel: +86 755 2601-0565
Fax: +86 755 2601-0500
elan-sz@elanic.com.cn

Shanghai:**Elan Microelectronics Shanghai, Ltd.**

6F, Ke Yuan Building
No. 5, Bibo Road
Zhangjiang Hi-Tech Park
Shanghai, CHINA 201203
Tel: +86 21 5080-3866
Fax: +86 21 5080-0273
elan-sh@elanic.com.cn

Contents

1	General Description	1
2	Features	1
2.1	Features Selection Guide	2
3	Pin Assignment	3
3.1	EM78F648N / 548N Pin Assignment	3
3.2	EM78F644N / 544N Pin Assignment	4
3.3	EM78F642N / 542N Pin Assignment	4
3.4	EM78F641N / 541N Pin Assignment	5
4	Pin Description	5
4.1	EM78F648N / 548N Pin Description	5
4.2	EM78F644N / 544N Pin Description	8
4.3	EM78F642N / 542N Pin Description	10
4.4	EM78F641N / 541N Pin Description	11
5	Block Diagram	12
6	Functional Description	13
6.1	Operational Registers (for EM78F644/642/641/544/542/541N Series only)	13
6.1.1	R0 (Indirect Addressing Register)	13
6.1.2	R1 (Timer Clock/Counter)	13
6.1.3	R2 (Program Counter and Stack)	13
6.1.4	R3 (Status Register)	16
6.1.5	R4 (RAM Select Register)	16
6.1.6	Bank 0 R5 (Port 5)	16
6.1.7	Bank 0 R6 (Port 6)	17
6.1.8	Bank 0 R7 (Port 7)	17
6.1.9	Bank 0 R8 (Port 8)	17
6.1.10	Bank 0 R9 (TBLP: Table Point Register for Instruction TBRD)	17
6.1.11	Bank 0 RA (Wake-up Control Register)	18
6.1.12	Bank 0 RB (EEPROM Control Register)	18
6.1.13	Bank 0 RC (256 Bytes EEPROM Address)	19
6.1.14	Bank 0 RD (256 Bytes EEPROM Data)	19
6.1.15	Bank 0 RE (Mode Select Register)	20
6.1.16	Bank 0 RF (Interrupt Status Register 1)	21
6.1.17	R10 ~ R3F	22
6.1.18	Bank 1 R5 TC1CR (Timer 1 Control)	22
6.1.19	Bank 1 R6 TCR1DA (Timer 1 Data Buffer A)	24
6.1.20	Bank 1 R7 TCR1DB (Timer 1 Data Buffer B)	24

6.1.21	Bank 1 R8 TC2CR (Timer 2 Control)	25
6.1.22	Bank 1 R9 TC2DH (Timer 2 High Byte Data Buffer)	29
6.1.23	Bank 1 RA TC2DL (Timer 2 Low Byte Data Buffer)	29
6.1.24	Bank 1 RB SPIS (SPI Status Register)	29
6.1.25	Bank 1 RC SPIC (SPI Control Register)	30
6.1.26	Bank 1 RD SPIRB (SPI Read Buffer)	31
6.1.27	Bank 1 RE SPIWB (SPI Write Data Buffer)	32
6.1.28	Bank 1 RF (Interrupt Status Register 2)	32
6.1.29	Bank 2 RA URC1 (UART Control 1)	32
6.1.30	Bank 2 RB URC2 (UART Control 2)	33
6.1.31	Bank 2 RC URS (UART Status)	34
6.1.32	Bank 2 RD URRD (UART_RD Data Buffer)	35
6.1.33	Bank 2 RE URTD (UART_TD Data Buffer)	35
6.1.34	Bank 2 RF (Pull-high Control Register 1)	35
6.1.35	Bank 3 R5 (TMRCON: Timer A and Timer B Control Register)	36
6.1.36	Bank 3 R6 (TBHP: Table Pointer Register for Instruction TBRD)	36
6.1.37	Bank 3 R7 (CMPCON: Comparator 2 Control Register and PWMA/B Control Register)	37
6.1.38	Bank 3 R8 (PWMCON: PWMA/B Lower 2 Bits of the Period and Duty Control Register)	37
6.1.39	Bank 3 R9 (PRDAH: Most Significant Byte of PWMA)	38
6.1.40	Bank 3 RA (DTAH: Most Significant Byte of PWMA Duty Cycle)	38
6.1.41	Bank 3 RB (PRDBH: Most Significant Byte of PWMB)	38
6.1.42	Bank 3 RC (DTBH: Least Significant Byte of PWMB Duty Cycle)	38
6.1.43	Bank 3 RD TC3CR (Timer 3 Control)	39
6.1.44	Bank 3 RE TC3D (Timer 3 Data Buffer)	41
6.1.45	Bank 3 RF (Pull-Down Control Register 1)	41
6.2	Special Function Registers (EM78F644/642/641/544/542/541N Series only)	42
6.2.1	A (Accumulator)	42
6.2.2	CONT (Control Register)	42
6.2.3	IOC5 (I/O Port 5 Control Register)	43
6.2.4	IOC6 (I/O Port 6 Control Register)	43
6.2.5	IOC7 (I/O Port 7 Control Register)	44
6.2.6	IOC8 (I/O Port 8 Control Register)	44
6.2.7	IOC9	44
6.2.8	IOCA (WDT Control Register)	44
6.2.9	IOCB (Pull-Down Control Register 2)	45
6.2.10	IOCC (Open-Drain Control Register)	46
6.2.11	IOCD (Pull-High Control Register 2)	46
6.2.12	IOCE (Interrupt Mask Register 2)	47
6.2.13	IOCF (Interrupt Mask Register 1)	48

6.3	Operational Registers for EM78F648/548N	49
6.3.1	R0: IAR (Indirect Addressing Register)	49
6.3.2	R1: BSR (Bank Selection Control Register)	49
6.3.3	R2: PC (Program Counter)	49
6.3.4	R3: SR (Status Register).....	53
6.3.5	R4: RSR (RAM Select Register).....	54
6.3.6	Bank 0 R5 ~ R9 (Port 5 ~ Port 9).....	54
6.3.7	Bank 0 RA (Not Used).....	54
6.3.8	Bank 0 RB OMCR (Operating Mode Control Register)	54
6.3.9	Bank 0 RC: ISR1 (Interrupt Status Register 1)	56
6.3.10	Bank 0 RD: ISR2 (Interrupt Status Register 2)	57
6.3.11	Bank 0 RE: ISR3 (Interrupt Status Register 3)	57
6.3.12	Bank 0 RF	58
6.3.13	Bank 0 R10: EIESCR (External Interrupt Edge Select Control Register)	58
6.3.14	Bank 0 R11: WDTCR	58
6.3.15	Bank 0 R12: LVDCR (Low Voltage Detector Control Register)	59
6.3.16	Bank 0 R13: TCCCR (TCC Control Register).....	59
6.3.17	Bank 0 R14: TCCDATA (TCC Data Register)	60
6.3.18	Bank 0 R15~R19 (IOCR5~IOCR9).....	60
6.3.19	Bank 0 R1A~R1B	60
6.3.20	Bank 0 R1C: IMR1 (Interrupt Mask Register 1)	60
6.3.21	Bank 0 R1D: IMR2 (Interrupt Mask Register 2)	61
6.3.22	Bank 0 R1E: IMR3 (Interrupt Mask Register 3)	62
6.3.23	Bank 0 R1F	62
6.3.24	Bank 0 R20: P5WUCR (Port 5 Wake Up Control Register).....	63
6.3.25	Bank 0 R21: P5WUECR (Port 5 Wake-up Edge Control Register)	63
6.3.26	Bank 0 R22: P7WUCR (Port 7 Wake-up Control Register)	63
6.3.27	Bank 0 R23: P7WUECR (Port 7 Wake-up Edge Control Register)	63
6.3.28	Bank 0 R24~R2A	63
6.3.29	Bank 0 R2B: SPICR (SPI Control Register)	64
6.3.30	Bank0 R2C: SPIS (SPI Status Register).....	65
6.3.31	Bank 0 R2D: SPIR (SPI Read Buffer Register)	65
6.3.32	Bank 0 R2E: SPIR (SPI Write Buffer Register).....	65
6.3.33	Bank 0 R2F: WUCR1 (Wake-up Control Register 1).....	66
6.3.34	Bank 0 R30~R31.....	66
6.3.35	Bank 0 R32: URCCR1 (UART Control Register 1).....	67
6.3.36	Bank 0 R33: URCCR2 (UART Control Register 2).....	67
6.3.37	Bank 0 R34: URS (UART Status Register)	68
6.3.38	Bank 0 R35: URRD (UART Receive Data Buffer Register)	69
6.3.39	Bank 0 R36: URTD (UART Transmit Data Buffer Register).....	69
6.3.40	Bank 0 R37: TBPTL (Table Pointer Low Register).....	69
6.3.41	Bank 0 R38: TBPTH (Table Pointer High Register)	69

6.3.42	Bank 0 R39: CMP1CR (Comparator 1 Control Register)	69
6.3.43	Bank 0 R3A~R3B	70
6.3.44	Bank 0 R3C: CMP2CR (Comparator 2 Control Register)	71
6.3.45	Bank 0 R3D~R42	72
6.3.46	Bank 0 R43: CPIRLCON (Comparator Internal Reference Level Control Register)	72
6.3.47	Bank 0 R44~R47	72
6.3.48	Bank 0 R48: TC1CR (Timer 1 Control Register)	72
6.3.49	Bank 0 R49: TCR1DA (Timer 1 Data Buffer A)	75
6.3.50	Bank 0 R4A: TCR1DB (Timer 1 Data Buffer B)	75
6.3.51	Bank 0 R4B: TC2CR (Timer 2 Control Register)	75
6.3.52	Bank 0 R4C: TCR2DH (Timer 2 High Byte Data Buffer Register)	77
6.3.53	Bank 0 R4D: TCR2DL (Timer 2 Low Byte Data Buffer Register)	78
6.3.54	Bank 0 R4E: TC3CR (Timer 3 Control Register)	78
6.3.55	Bank 0 R4F: TCR3D (Timer 3 Duty Buffer Register)	80
6.3.56	Bank 1 R5: P5PHCR (Port 5 Pull High Control Register)	80
6.3.57	Bank 1 R6: P6PHCR (Port 6 Pull High Control Register)	81
6.3.58	Bank 1 R7: P7PHCR (Port 7 Pull High Control Register)	81
6.3.59	Bank 1 R8: P8PHCR (Port 8 Pull High Control Register)	81
6.3.60	Bank 1 R9: P9PHCR (Port 9 Pull High Control Register)	82
6.3.61	Bank 1 RA	82
6.3.62	Bank 1 RB: P5PLCR (Port 5 Pull Low Control Register)	82
6.3.63	Bank 1 RC: P6PLCR (Port 6 Pull Low Control Register)	83
6.3.64	Bank 1 RD: P7PLCR (Port 7 Pull Low Control Register)	83
6.3.65	Bank 1 RE: P8PLCR (Port 8 Pull Low Control Register)	84
6.3.66	Bank 1 RF: P9PLCR (Port 9 Pull Low Control Register)	84
6.3.67	Bank 1 R10	84
6.3.68	Bank 1 R11: P5HD/SCR (Port 5 High Drive/Sink Control Register)	84
6.3.69	Bank 1 R12: P6HD/SCR (Port 6 High Drive/Sink Control Register)	85
6.3.70	Bank 1 R13: P7HD/SCR (Port 7 High Drive/Sink Control Register)	85
6.3.71	Bank 1 R14: P8HD/SCR (Port 8 High Drive/Sink Control Register)	85
6.3.72	Bank 1 R15: P9HD/SCR (Port 9 High Drive/Sink Control Register)	85
6.3.73	Bank 1 R16	85
6.3.74	Bank 1 R17: P5ODCR (Port 5 Open Drain Control Register)	86
6.3.75	Bank 1 R18: P6ODCR (Port 6 Open Drain Control Register)	86
6.3.76	Bank 1 R19: P7ODCR (Port 7 Open Drain Control Register)	86
6.3.77	Bank 1 R1A: P8ODCR (Port 8 Open Drain Control Register)	86
6.3.78	Bank 1 R1B: P9ODCR (Port 9 Open Drain Control Register)	86
6.3.79	Bank 1 R1C	87
6.3.80	Bank 1 R1D: IRCS (IRC Frequency Selection Register)	87
6.3.81	Bank 1 R1E	87
6.3.82	Bank 1 R1F: EEPROM Control	87

6.3.83	Bank 1 R20: EEPROM ADDR.....	88
6.3.84	Bank 1 R21: EEPROM DATA.....	88
6.3.85	Bank1 R22.....	88
6.3.86	Bank1 R23: I2CCR1 (I2C Status and Control Register 1)	88
6.3.87	Bank 1 R24: I2CCR2 (I2C Status and Control Register2)	89
6.3.88	Bank 1 R25: I2CSA (I2C Slave Address Register).....	90
6.3.89	Bank 1 R26: I2CDA (I2C Device Address Register)	90
6.3.90	Bank 1 R27: I2CDB (I2C Data Buffer Register)	91
6.3.91	Bank 1 R28: I2CA (I2C Data Buffer Register)	91
6.3.92	Bank 1 R29.....	91
6.3.93	Bank 1 R2A: PWMER (PWM Enable Control Register).....	91
6.3.94	Bank 1 R2B: TIMEN (Timer/PWM Enable Control Register)	91
6.3.95	Bank 1 R2C~R2E.....	92
6.3.96	Bank 1 R2F: PWMACR (PWM A Control Register)	92
6.3.97	Bank 1 R30: PWMBCR (PWM B Control Register)	92
6.3.98	Bank 1 R31.....	92
6.3.99	Bank 1 R32: TACR (Timer A Control Register)	92
6.3.100	Bank1 R33: TBCR (Timer B Control Register).....	93
6.3.101	Bank 1 R34.....	93
6.3.102	Bank 1 R35: TAPRDH (Timer A Period Buffer Register).....	93
6.3.103	Bank 1 R36: TBPRDH (Timer B Period Buffer Register)	93
6.3.104	Bank 1 R37.....	93
6.3.105	Bank 1 R38: TADTH (Timer A Duty Buffer Register).....	93
6.3.106	Bank 1 R39: TBDTH (Timer B Duty Buffer Register)	93
6.3.107	Bank1 R3A	93
6.3.108	Bank 1 R3B: PRDxL (PWM A/B/C Period Buffer Low Bits Register)	94
6.3.109	Bank 1 R3C: DTxL (PWM1/2 Duty Buffer Low Bits Register).....	94
6.3.110	Bank 1 R3D~R4F	94
6.3.111	Bank 0 R50~R7F, Bank0~1 R80~RFF	94
6.4	TCC/WDT and Prescaler.....	94
6.5	I/O Ports	95
6.5.1	I/O for EM78F644N/642/641/544/542/541N	95
6.5.2	I/O for EM78F648/548N	96
6.6	UART (Universal Asynchronous Receiver/Transmitter).....	97
6.6.1	UART Mode.....	98
6.6.2	Transmitting.....	98
6.6.3	Receiving	99
6.6.4	Baud Rate Generator	99
6.6.5	UART Timing.....	99

6.7	SPI Function.....	100
6.7.1	Overview and Features.....	100
6.7.1.1	Overview.....	100
6.7.1.2	Features.....	100
6.7.2	SPI Function Description.....	102
6.7.3	SPI Signal and Pin Description.....	103
6.7.4	SPI Mode Timing.....	105
6.8	I2C Function.....	106
6.8.1	7-Bit Slave Address.....	108
6.8.2	10-Bit Slave Address.....	108
6.8.2.1	Master-Transmitter Transmits to Slave-Receiver with a 10-bit Slave Address.....	109
6.8.2.2	Master-Receiver Reads from Slave-Transmitter with a 10-bit Slave Address.....	109
6.8.2.3	Master Transmits and Receives Data to and from the Same Slave Device with 10-Bit Addresses.....	110
6.8.2.4	Master Device Transmits Data to Two or More Slave Devices with 10 and 7 Bits Slave Address.....	110
6.8.3	Master Mode I2C Transmit.....	112
6.8.2	Slave Mode I2C Transmit.....	112
6.9	Dual Set of PWM (Pulse Width Modulation).....	112
6.9.1	Overview.....	112
6.9.2	Increment Timer Counter (TMRX: TMRAH/L or TMRBH/L).....	113
6.9.3	PWM Period (PRDX: PRDA or PRDB).....	114
6.9.4	PWM Duty Cycle (DTX: DTA or DTB).....	114
6.10	Comparator.....	115
6.10.1	External Reference Signal.....	115
6.10.2	Internal Reference Signal.....	115
6.10.3	Comparator Outputs.....	116
6.10.4	Interrupt.....	116
6.10.5	Wake-up from Sleep Mode.....	117
6.11	Reset and Wake-up.....	117
6.11.1	Reset and Wake-up for EM78F644/642/641/544/542/541N.....	117
6.11.2	Reset and Wake-up for EM78F648/548N.....	128
6.11.3	The Status of RST, T, and P of STATUS Register.....	143
6.12	Interrupt.....	144
6.12.1	Interrupt for EM78F644/642/641/544/542/541N.....	144
6.12.2	Interrupt for EM78F648/548N.....	146
6.13	LVD (Low Voltage Detector) for EM78F648/548N.....	147
6.13.1	LVD Level Control.....	147
6.13.2	LVD Interrupt.....	148
6.13.3	LVD Function Setup.....	148

6.14	Data EEPROM	150
6.15	Oscillator	150
6.15.1	Oscillator Modes	150
6.15.2	Crystal Oscillator/Ceramic Resonators (XTAL).....	151
6.15.3	External RC Oscillator Mode.....	152
6.15.4	Internal RC Oscillator Mode.....	153
6.16	Power-on Considerations	154
6.17	External Power-on Reset Circuit	154
6.18	Residue-Voltage Protection	155
6.19	Code Option Register.....	156
6.19.1	Code Option Register (Word 0)	156
6.19.1.1	EM78F644/642/641/544/542/541N Code Option Word 0.....	156
6.19.1.1	EM78F648/548 Code Option Word 0	158
6.19.2	Code Option Register (Word 1)	159
6.19.2.1	EM78F644/642/641/544/542/541N Code Option Word 1.....	159
6.19.2.2	EM78F648/548N Code Option Word 1	160
6.19.3	Customer ID Register (Word 2)	161
6.19.3.1	EM78F644/642/641/544/542/541N Code Option Word 2.....	161
6.19.3.2	EM78F648/548N Code Option Word 2	161
6.20	Instruction Set	161
6.20.1	Instruction Set Table.....	162
7	Timing Diagram	166
7.1	AC Test Input/Output Waveform.....	166
7.2	Reset Timing (CLK1:0 = "01")	166
8	Absolute Maximum Ratings	167
8.1	For EM78F648/548N.....	167
9	DC Electrical Characteristics	167
9.1	For EM78F648/548N.....	167
9.1.1	Program Flash Memory Electrical Characteristics.....	169
9.1.2	Data EEPROM Electrical Characteristics (for EM78F648N only).....	169
9.1.3	Comparator Electrical Characteristics.....	169
9.2	For EM78F644/544N.....	170
9.2.1	Program Flash Memory Electrical Characteristics.....	172
9.2.2	Data EEPROM Electrical Characteristics (for EM78F644N only).....	172
9.2.3	Comparator Electrical Characteristics.....	172
9.3	EM78F642/542N	173
9.3.1	Program Flash Memory Electrical Characteristics.....	175
9.3.2	Data EEPROM Electrical Characteristics (for EM78F642N only).....	175
9.3.3	Comparator Electrical Characteristics.....	175



9.4	EM78F641/541N	176
9.4.1	Program Flash Memory Electrical Characteristics	178
9.4.2	Data EEPROM Electrical Characteristics (for EM78F641N only)	178
9.4.3	Comparator Electrical Characteristics	178
10	AC Electrical Characteristics	179
10.1	EM78F648/548N	179
10.2	EM78F644/642/641/544/542/541N	179

APPENDIX

A	Package Type	180
A.1	Green Products Compliance	180
B	Packaging Configuration	181
B.1	EM78F648/548N	181
B.1.1	44-Pin QFP Package	181
B.1.2	40-Pin DIP Package	182
B.1.3	28-Pin Skinny DIP Package	183
B.1.4	28-Pin DIP Package	184
B.1.5	28-Pin SOP Package	185
B.2	EM78F644/544N	186
B.2.1	28-Pin Skinny DIP Package	186
B.2.2	28-Pin SOP Package	187
B.2.3	24-Pin Skinny DIP Package	188
B.2.4	24-Pin SOP Package	189
B.3	EM78F642/542N	190
B.3.1	20-Pin DIP Package	190
B.3.2	20-Pin SOP Package	191
B.3.3	20-Pin SSOP Package	192
B.3.4	18-Pin DIP Package	193
B.3.5	18-Pin SOP Package	194
B.4	EM78F641/541N	195
B.4.1	16-Pin DIP Package	195
B.4.2	16-Pin SOP Package	196
B.4.3	10-Pin MSOP Package	197
C	Quality Assurance and Reliability	198
C.1	Address Trap Detect	198

Specification Revision History

Doc. Version	Revision Description	Date
1.0	Initial release version	2010/05/05
1.1	<ol style="list-style-type: none">1. Modified the contents of the Operating Frequency Range vs. Operating Voltage in Section 2 <i>Features</i>2. Modified the description of the Control-bit TS.3. Modified the descriptions in the Section <i>TCC/WDT and Prescaler</i>.4. Modified Figure 6-11 <i>TCC and WDT Block Diagram</i>.5. Modified the maximum supportable baud rate of the SPI function.	2012/07/17
1.2	<ol style="list-style-type: none">1. Modified the pin number of EM78F641/541N in Figure 3-42. Added LVR specification in the DC Electrical Characteristics section.	2013/03/15



1 General Description

The EM78F64xN/54xN Series are 8-bit microprocessors designed and developed with low-power, high-speed CMOS technology, and high noise immunity. Each of these MUCs are equipped with on-chip 1/2/4K×13-bit and 8K×15-bit Electrical Flash Memory, but only the EM78F64xN are embedded with 256 or 128×8-bit in-system programmable EEPROM. Each provides three protection bits to prevent intrusion of user's Flash memory code. Twelve Code option bits are also available to meet user's requirements.

With its enhanced Flash-ROM features, the EM78F64xN/54xN MUCs provide a convenient way of developing and verifying user's programs. Moreover, the Flash-ROM device offers the advantages of easy and effective program updates with development and programming tools. Users can take advantage of ELAN's Writer to easily program their development codes.

2 Features

■ CPU Configuration

CPU	EM78F648N	EM78F644N	EM78F642N	EM78F641N
	EM78F548N	EM78F544N	EM78F542N	EM78F541N
ROM	8K × 15 bits	4K × 13 bits	2K × 13 bits	1K × 13 bits
SRAM	304 × 8 bits	144 × 8 bits	80 × 8 bits	48 × 8 bits
EEPROM	256 bytes (648N only)	256 bytes (644N only)	128 bytes (642N only)	128 bytes (641N only)
STACK	8-Level	8-Level	8-Level	8-Level
LVR	4.2, 3.7, 2.7V	4.0, 3.5, 2.7V	4.0, 3.5, 2.7V	4.0, 3.5, 2.7V
LVD	2.3 / 3.3 / 4.0 / 4.5 V	x	x	x

- In-system programmable EEPROM
Endurance: 1,000,000 write/erase cycles
- More than 10 years data retention
- Less than 1.5 mA at 5V / 4 MHz
- Typically 20 μA, at 3V / 32kHz
- Typically 1.5 μA, during Sleep mode

■ I/O Port Configuration

I/O Port	EM78F648N	EM78F644N	EM78F642N	EM78F641N
	EM78F548N	EM78F544N	EM78F542N	EM78F541N
I/O	P5, P6, P7, P8, P9	P5, P6, P7, P8	P5, P6, P7, P8	P5, P6, P8
Pull-High	40	14	10	6
Pull-Down	40	14	7	5
Open-drain	40	8	8	6
High Sink	40	x	x	x
High Sink	40	x	x	x

- Wake-up port: P6
- External interrupt with Wake-up: P60

■ Operating Frequency Range (Base On Two Clocks)

Operating Frequency	EM78F648N	EM78F644N	EM78F642N	EM78F641N
	EM78F548N	EM78F544N	EM78F542N	EM78F541N
Crystal Mode	DC ~ 4 MHz 2.4 ~ 5.5V	DC ~ 4 MHz 2.3 ~ 5.5V	DC ~ 4 MHz 2.2 ~ 5.5V	DC ~ 4 MHz 2.2 ~ 5.5V
ERC Mode	DC ~ 8 MHz 3 ~ 5.5V	DC ~ 8 MHz 3 ~ 5.5V	DC ~ 8 MHz 3 ~ 5.5V	DC ~ 8 MHz 3 ~ 5.5V
IRC Mode	DC ~ 20 MHz 5 ~ 5.5V	DC ~ 16 MHz 4.5 ~ 5.5V	DC ~ 16 MHz 4.5 ~ 5.5V	DC ~ 16 MHz 4.5 ~ 5.5V

■ Available Interrupts

Interrupt	EM78F648N	EM78F644N	EM78F642N	EM78F641N
	EM78F548N	EM78F544N	EM78F542N	EM78F541N
Internal	15	10	4	2
External	4	3	3	3

■ Peripheral Configuration

Function	EM78F648N	EM78F644N	EM78F642N	EM78F641N
	EM78F548N	EM78F544N	EM78F542N	EM78F541N
Two channel PWM	10-bit resolution	10-bit resolution	x	x
One 8-bit Timer/counter (TC1)	Timer Counter Capture	Timer Counter Capture	Timer Counter Capture	x
One 16-bit Timer/counter (TC2)	Timer Counter Window	Timer Counter Window	Timer only	x
One 8-bit Timer/counter (TC3)	Timer Counter PWM / PDO	Timer Counter PWM / PDO	Timer Counter PWM / PDO	Timer Counter PWM / PDO
One-set Comparator	10mv offset voltage	10mv offset voltage	5mv offset voltage	5mv offset voltage

- 8-bit real time clock/counter (TCC) with selective signal sources, trigger edges, and overflow interrupt
- External interrupt input pin
- 2-/4-/8-/16 clocks per instruction cycle selected by code option

EM78F648/644/642/641/548/544/542/541N

8-Bit Microcontroller



Operating Voltage Range

Operating Voltage	EM78F648N	EM78F644N	EM78F642N	EM78F641N
	EM78F548N	EM78F544N	EM78F542N	EM78F541N
Commercial 0°C~70°C	2.4 ~ 5.5V	2.2 ~ 5.5V	2.2 ~ 5.5V	2.2 ~ 5.5V
Industrial -40°C~85°C	2.6 ~ 5.5V	2.4 ~ 5.5V	2.4 ~ 5.5V	2.4 ~ 5.5V

Communication Peripheral Configuration

Function	EM78F648N	EM78F644N	EM78F642N	EM78F641N
	EM78F548N	EM78F544N	EM78F542N	EM78F541N
SPI	Three wire synchronous communication	Three wire synchronous communication	x	x
UART	Two wire Asynchronous communication	Two wire Asynchronous communication	x	x
I2C	7 / 10 bits Address & 8 bits data	x	x	x

Internal RC Drift Rate

Internal RC Frequency	Drift Rate			
	Temperature (-40°C~85°C)	Voltage (2.2V~5.5V)	Process	Total
4 MHz	± 3%	± 5%	± 2.5%	± 10.5%
16 MHz	± 3%	± 5%	± 2.5%	± 10.5%
8 MHz	± 3%	± 5%	± 2.5%	± 10.5%
*455kHz	± 3%	± 5%	± 2.5%	± 10.5%

*NOT applicable to EM78F541N and EM78F641N

- Power down (Sleep) mode
- High EFT immunity

Special Features

- Programmable free running Watchdog Timer
- Power-on voltage detector available (2.0V ~ 2.1V)

EM78F648N/548N Package Types

- 44-pin QFP 10x10 mm : EM78Fx48NQ44J/S
- 40-pin DIP 600 mil : EM78Fx48ND40J/S
- 28-pin SKDIP 300 mil : EM78Fx48NK28J/S
- 28-pin SOP 300 mil : EM78Fx48NSO28J/S

EM78F644N/544N Package Types

- 28-pin SKDIP 300 mil : EM78Fx44NK28J/S
- 28-pin SOP 300 mil : EM78Fx44NSO28J/S
- 24-pin SKDIP 300 mil : EM78Fx44NK24J/S
- 24-pin SOP 300 mil : EM78Fx44NSO24J/S

EM78F642N/542N Package Types

- 20-pin DIP 300 mil : EM78Fx42ND20J/S
- 20-pin SOP 300 mil : EM78Fx42NSO20J/S
- 20-pin SSOP 209 mil : EM78Fx42NSS20J/S
- 18-pin DIP 300 mil : EM78Fx42ND18J/S
- 18-pin SOP 300 mil : EM78Fx42NSO20J/S

EM78F641N/541N Package Types

- 16-pin DIP 300 mil : EM78Fx41NAD16J/S
- 16-pin SOP 150 mil : EM78Fx41NASO16J/S
- 10-pin MSOP 118 mil : EM78Fx41NMS10J/S

NOTE

These are Green Products which do not contain hazardous substances.

2.1 Features Selection Guide

Part No.	VDD	Program Memory	Data Memory	I/O	Timer		PWM	UART	SPI	I2C	Package Type
					8-bit	16-bit					
EM78Fx48N	2.4 ~ 5.5V	8K x 15 bits	304 x 8 bits	40	2	1	2 ch x 10 bits	Two wire synchronous communication	Three wire Asynchronous communication	7 / 10 bits Address & 8 bits data	44 QFP 40 DIP 28 SKDIP/SOP
EM78Fx44N	2.2 ~ 5.5V	4K x 13 bits	144 x 8 bits	25	2	1	2 ch x 10 bits	Two wire synchronous communication	Three wire Asynchronous communication	x	28 SKDIP/SOP 24 SKDIP/SOP
EM78Fx42N	2.2 ~ 5.5V	2K x 13 bits	80 x 8 bits	18	2	1	x	x	x	x	20 DIP/SOP 18 DIP/SOP
EM78Fx41N	2.2 ~ 5.5V	1K x 13 bits	48 x 8 bits	14	1	0	x	x	x	x	16 DIP/SOP 10 MSOP

3 Pin Assignment

3.1 EM78F648N / 548N Pin Assignment

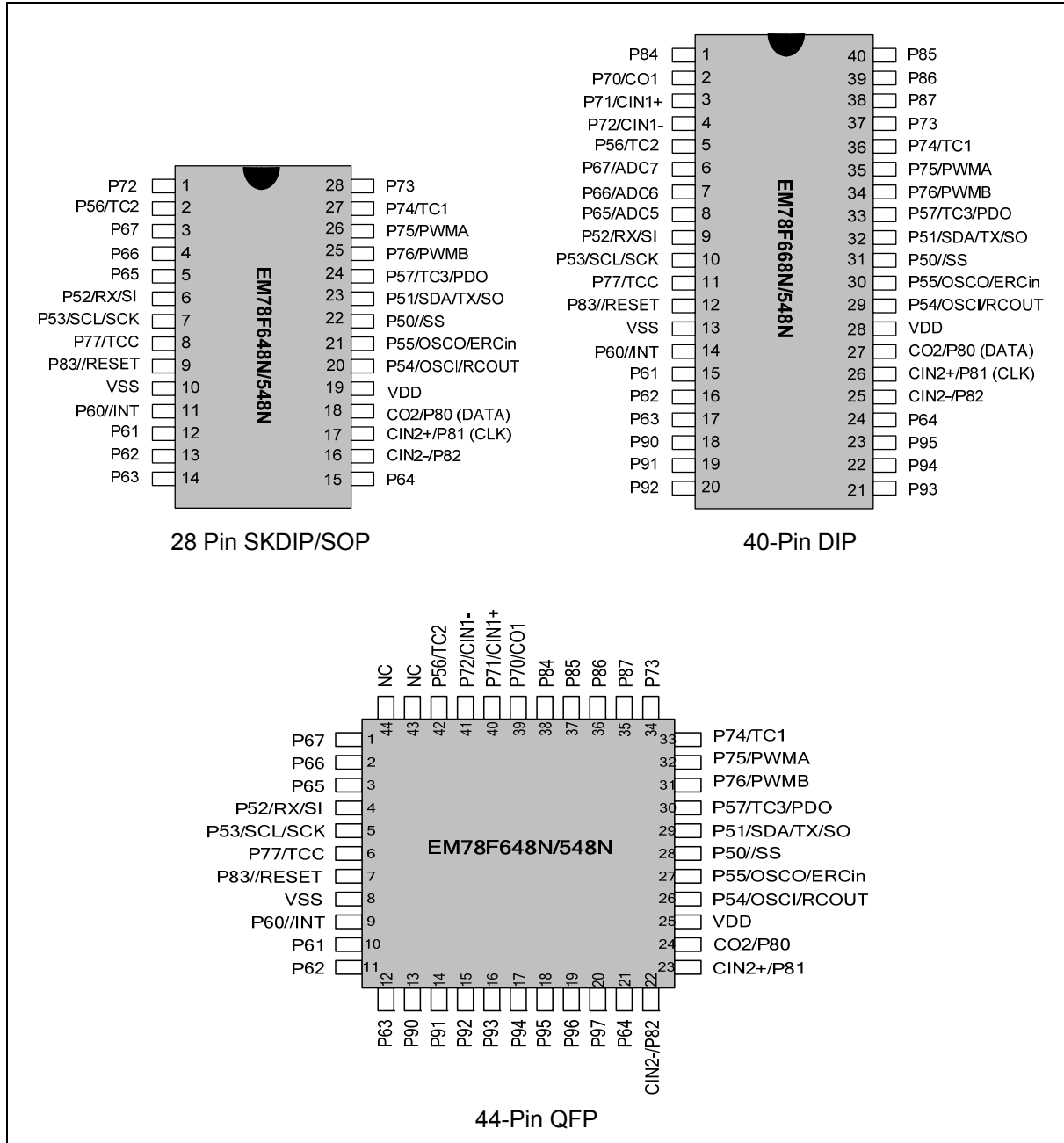

Figure 3-1 EM78F648N / 548N Pin Assignment

3.2 EM78F644N / 544N Pin Assignment

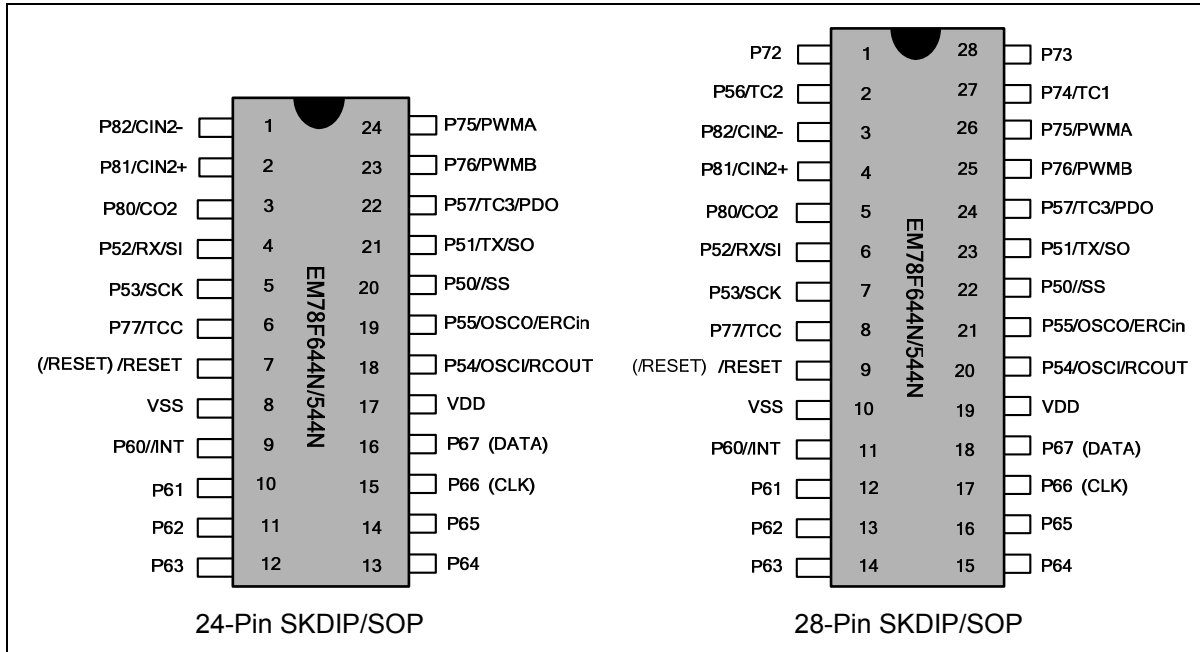

Figure 3-2 EM78F644N / 544N Pin Assignment

3.3 EM78F642N / 542N Pin Assignment

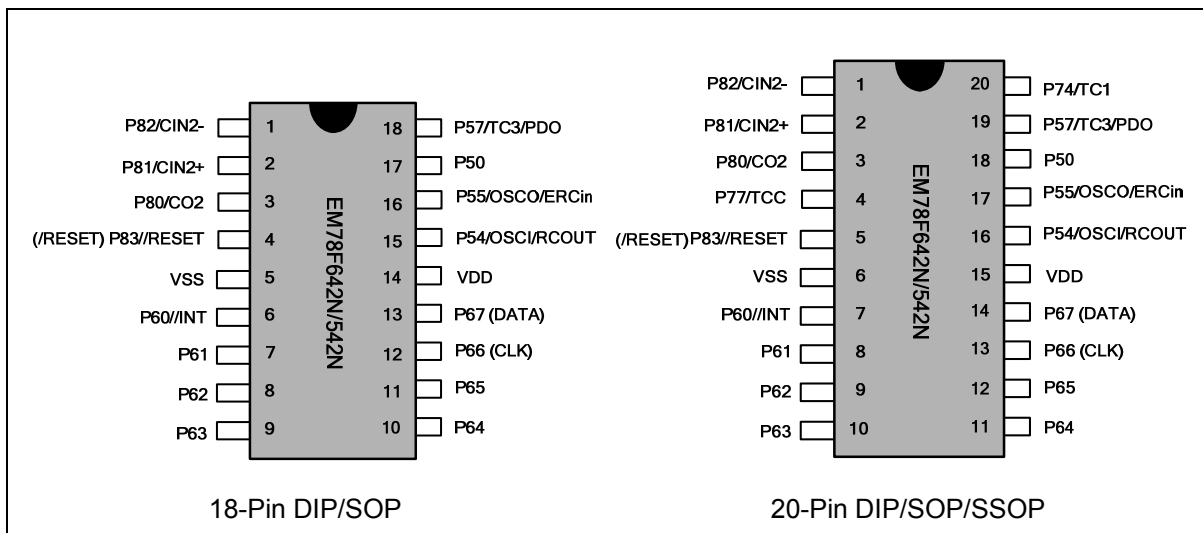

Figure 3-3 EM78F642N / 542N Pin Assignment

3.4 EM78F641N / 541N Pin Assignment

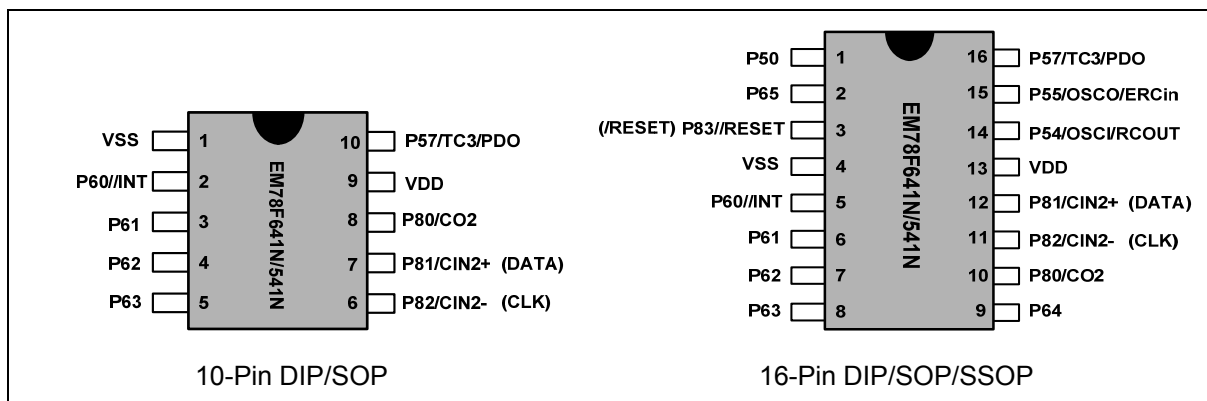

Figure 3-4 EM78F641N / 541N Pin Assignment

4 Pin Description

4.1 EM78F648N / 548N Pin Description

Name	Function	Input Type	Output Type	Description
P50//SS	P50	ST	CMOS	Bidirectional I/O pin with programmable pull-down, open-drain, pull-high, high sink and high drive.
	/SS	ST		SPI slave select pin
P51/SDA/TX/SO	P51	ST	CMOS	Bidirectional I/O pin with programmable pull-down, open-drain, pull-high, high sink and high drive.
	TX		CMOS	UART TX output
	SO		CMOS	SPI serial data output
	SDA	ST	CMOS	I2C serial data (open-drain)
P52/RX/SI	P52	ST	CMOS	Bidirectional I/O pin with programmable pull-down, open-drain, pull-high, high sink and high drive.
	RX	ST		UART RX input
	SI	ST		SPI serial data input
P53/SCK/SCL	P53	ST	CMOS	Bidirectional I/O pin with programmable pull-down, open-drain, pull-high, high sink and high drive.
	SCK	ST	CMOS	SPI serial clock input/output
	SCL	ST	CMOS	I2C serial clock (open-drain)

(Continuation)

Name	Function	Input Type	Output Type	Description
P54/OSCI/RCOUT	P54	ST	CMOS	Bidirectional I/O pin with programmable pull-down, open-drain, pull-high, high sink and high drive.
	OSCI	XTAL		Clock input of crystal/resonator oscillator
	RCOUT		CMOS	Clock output of internal RC oscillator Clock output of external RC oscillator (open-drain)
P55/OSCO/ERCin	P55	ST	CMOS	Bidirectional I/O pin with programmable pull-down, open-drain, pull-high, high sink and high drive.
	OSCO	XTAL		Clock output of crystal/resonator oscillator
	ERCin		AN	External RC input pin
P56/TC2	P56	ST	CMOS	Bidirectional I/O pin with programmable pull-down, open-drain, pull-high, high sink and high drive.
	TC2	ST		Timer 2 clock input
P57/TC3/PDO	P57	ST	CMOS	Bidirectional I/O pin with programmable pull-down, open-drain, pull-high, high sink and high drive.
	TC3	ST		Timer 3 clock input
	PDO		CMOS	Programmable divider output
P60//INT	P60	ST	CMOS	Bidirectional I/O pin with programmable pull-down, open-drain, pull-high, high sink, high drive and pin change wakeup.
	//INT	ST		External interrupt pin
P61~P67	P61~P67	ST	CMOS	Bidirectional I/O pin with programmable pull-down, open-drain, pull-high, high sink, high drive and pin change wakeup.
P70/CO1	P70	ST	CMOS	Bidirectional I/O pin with programmable pull-down, open-drain, pull-high, high sink and high drive.
	CO1		CMOS	Output of Comparator 1
P71/CIN1+	P71	ST	CMOS	Bidirectional I/O pin with programmable pull-down, open-drain, pull-high, high sink and high drive.
	CIN1+	AN		Non-inverting end of Comparator 1
P72/CIN1-	P72	ST	CMOS	Bidirectional I/O pin with programmable pull-down, open-drain, pull-high, high sink and high drive.
	CIN1-	AN		Inverting end of Comparator 1
P73	P73	ST	CMOS	Bidirectional I/O pin with programmable pull-down, open-drain, pull-high, high sink and high drive.
P74/TC1	P74	ST	CMOS	Bidirectional I/O pin with programmable pull-down, open-drain, pull-high, high sink and high drive.
	TC1		CMOS	Timer 1 clock input
P75/PWMA	P75	ST	CMOS	Bidirectional I/O pin with programmable pull-down, open-drain, pull-high, high sink and high drive.
	PWMA		CMOS	PWMA output
P76/PWMB	P76	ST	CMOS	Bidirectional I/O pin with programmable pull-down, open-drain, pull-high, high sink and high drive.
	PWMB		CMOS	PWMB output

(Continuation)

Name	Function	Input Type	Output Type	Description
P77/TCC	P77	ST	CMOS	Bidirectional I/O pin with programmable pull-down, open-drain, pull-high, high sink and high drive.
	TCC	ST		Real Time Clock/Counter clock input
P80/CO2	P80	ST	CMOS	Bidirectional I/O pin with programmable pull-down, open-drain, pull-high, high sink and high drive.
	CO2		CMOS	Output of Comparator 2
(DATA)	(DATA)	ST	CMOS	DATA pin for Writer programming
P81/CIN2+	P81	ST	CMOS	Bidirectional I/O pin with programmable pull-down, open-drain, pull-high, high sink and high drive.
	CIN2+	AN		Non-inverting end of Comparator 2
(CLK)	(CLK)	ST		Clock pin for Writer programming
P82/CIN2-	P82	ST	CMOS	Bidirectional I/O pin with programmable pull-down, open-drain, pull-high, high sink and high drive.
	CIN2-	AN		Inverting end of Comparator 2
P83/RESET	P83	ST	CMOS	Bidirectional I/O pin with programmable pull-down, open-drain, pull-high, high sink and high drive.
	/RESET	ST		Internal pull-high reset pin
(/RESET)	(/RESET)	ST	CMOS	/RESET pin for Writer programming
P84~P87	P84~P87	ST	CMOS	Bidirectional I/O pin with programmable pull-down, open-drain, pull-high, high sink and high drive.
P90~P97	P90~P97	ST	CMOS	Bidirectional I/O pin with programmable pull-down, open-drain, pull-high, high sink and high drive.
VDD	VDD	Power	–	Power
VSS	VSS	Power	–	Ground

Legend: **ST:** Schmitt Trigger input

XTAL: oscillation pin for crystal/ resonator

AN: analog pin

CMOS: CMOS output

4.2 EM78F644N / 544N Pin Description

Name	Function	Input Type	Output Type	Description
P50//SS	P50	ST	CMOS	Bidirectional I/O pin with programmable pull-down
	/SS	ST		SPI slave select pin
P51/TX/SO	P51	ST	CMOS	Bidirectional I/O pin with programmable pull-down
	TX		CMOS	UART TX output
	SO		CMOS	SPI serial data output
P52/RX/SI	P52	ST	CMOS	Bidirectional I/O pin with programmable pull-down
	RX	ST		UART RX input
	SI	ST		SPI serial data input
P53/SCK	P53	ST	CMOS	Bidirectional I/O pin with programmable pull-down
	SCK	ST	CMOS	SPI serial clock input/output
P54/OSCI/RCOUT	P54	ST	CMOS	Bidirectional I/O pin
	OSCI	XTAL	CMOS	Clock input of crystal/ resonator oscillator
	RCOUT		CMOS	Clock output of internal RC oscillator Clock output of external RC oscillator(open-drain)
P55/OSCO/ERCin	P55	ST	CMOS	Bidirectional I/O pin
	OSCO		XTAL	Clock output of crystal/ resonator oscillator
	ERCin	AN	CMOS	External RC input pin
P56/TC2	P56	ST	CMOS	Bidirectional I/O pin
	TC2	ST		Timer 2 clock input
P57/TC3/PDO	P57	ST	CMOS	Bidirectional I/O pin
	TC3	ST	CMOS	Timer 3 clock input
	PDO		CMOS	Programmable divider output
P60//INT	P60	ST	CMOS	Bidirectional I/O pin with programmable pull-down, open drain, pull-high and pin change wakeup.
	/INT	ST		External interrupt pin
P61~P63	P61~P63	ST	CMOS	Bidirectional I/O pin with programmable pull-down, open drain, pull-high and pin change wakeup.
P64~P65	P64~P65	ST	CMOS	Bidirectional I/O pin with programmable open-drain, pull-high and pin change wakeup.
P66 (CLK)	P66	ST	CMOS	Bidirectional I/O pin with programmable open-drain, pull-high and pin change wakeup.
	(CLK)	ST		Clock pin for Writer programming
P67 (DATA)	P67	ST	CMOS	Bidirectional I/O pin with programmable open-drain, pull-high and pin change wakeup.
	(DATA)	ST	CMOS	Data pin for Writer programming

(Continuation)

Name	Function	Input Type	Output Type	Description
P72 ~ P73	P72~P73	ST	CMOS	Bidirectional I/O pin with programmable pull-down and pull-high.
P74/TC1	P74	ST	CMOS	Bidirectional I/O pin with programmable pull-down and pull-high.
	TC1		CMOS	Timer 1 clock input
P75/PWMA	P75	ST	CMOS	Bidirectional I/O pin with programmable pull-down and pull-high.
	PWMA		CMOS	PWMA output
P76/PWMB	P76	ST	CMOS	Bidirectional I/O pin with programmable pull-down and pull-high.
	PWMB		CMOS	PWMB output
P77/TCC	P77	ST	CMOS	Bidirectional I/O pin with programmable pull-down and pull-high.
	TCC	ST		Real Time Clock/Counter clock input
P80/CO2	P80	ST	CMOS	Bidirectional I/O pin
	CO2		CMOS	Bidirectional I/O pin with programmable pull-down and pull-high.
P81/CIN2+	P81	ST	CMOS	Bidirectional I/O pin
	CIN2+	AN		Non-Inverting end of Comparator 2
P82/CIN2-	P82	ST	CMOS	Bidirectional I/O pin
	CIN2-	AN		Inverting end of Comparator 2
/RESET	/RESET	ST	CMOS	Internal pull-high reset pin
(/RESET)	(/RESET)	ST		/RESET pin for Writer programming
VDD	VDD	Power	–	Power
VSS	VSS	Power	–	Ground

Legend: **ST:** Schmitt Trigger input
XTAL: oscillation pin for crystal / resonator

AN: analog pin
CMOS: CMOS output

4.3 EM78F642N / 542N Pin Description

Name	Function	Input Type	Output Type	Description
P50	P50	ST	CMOS	Bidirectional I/O pin with programmable pull-down
P54/OSCI/RCOUT	P54	ST	CMOS	Bidirectional I/O pin
	OSCI	XTAL		Clock input of crystal/resonator oscillator
	RCOUT		CMOS	Clock output of internal RC oscillator Clock output of external RC oscillator (open-drain)
P55/OSCO/ERCin	P55		ST	CMOS
	OSCO	XTAL		Clock output of crystal / resonator oscillator
	ERCin	AN	CMOS	External RC input pin
P57/TC3/PDO	P57	ST	CMOS	Bidirectional I/O pin
	TC3	ST		Timer 3 clock input
	PDO			Programmable divider output
P60//INT	P60	ST	CMOS	Bidirectional I/O pin with programmable pull-down, open-drain, pull-high and pin change wakeup.
	//INT	ST		External interrupt pin
P61~P63	P61~P63	ST	CMOS	Bidirectional I/O pin with programmable pull-down, open-drain, pull-high and pin change wakeup.
P64~P65	P64~P65	ST	CMOS	Bidirectional I/O pin with programmable open-drain, pull-high and pin change wakeup.
P66 (CLK)	P66	ST	CMOS	Bidirectional I/O pin with programmable open-drain, pull-high and pin change wakeup.
	(CLK)	ST		Clock pin for Writer programming
P67 (DATA)	P67	ST	CMOS	Bidirectional I/O pin with programmable open-drain and pull-high.
	(DATA)	ST	CMOS	Data pin for Writer programming
P74/TC1	P74	ST	CMOS	Bidirectional I/O pin with programmable pull-down and pull-high.
	TC1		CMOS	Timer 1 clock input
P77/TCC	P77	ST	CMOS	Bidirectional I/O pin with programmable pull-down and pull-high.
	TCC	ST		Real Time Clock/Counter clock input
P80/CO2	P80	ST	CMOS	Bidirectional I/O pin
	CO2		CMOS	Output of Comparator 2
P81/CIN2+	P81	ST	CMOS	Bidirectional I/O pin
	CIN2+	AN		Non-inverting end of Comparator 2
P82/CIN2-	P82	ST	CMOS	Bidirectional I/O pin
	CIN2-	AN		Inverting end of Comparator 2



(Continuation)

Name	Function	Input Type	Output Type	Description
P83/RESET (/RESET)	P83	ST	CMOS	Bidirectional I/O pin
	/RESET	ST		Internal pull-high reset pin
	(/RESET)	(/RESET)	ST	CMOS
VDD	VDD	Power	–	Power
VSS	VSS	Power	–	Ground

Legend: **ST:** Schmitt Trigger input

XTAL: oscillation pin for crystal/ resonator

AN: analog pin,

CMOS: CMOS output

4.4 EM78F641N / 541N Pin Description

Name	Function	Input Type	Output Type	Description
P50	P50	ST	CMOS	Bidirectional I/O pin with programmable pull-down
P54/OSCI/RCOUT	P54	ST	CMOS	Bidirectional I/O pin
	OSCI	XTAL		CMOS
	RCOUT		CMOS	Clock output of internal RC oscillator Clock output of external RC oscillator (open-drain)
P55/OSCO/ERCin	P55	ST	CMOS	Bidirectional I/O pin
	OSCO		XTAL	Clock output of crystal/ resonator oscillator
	ERCin	AN	CMOS	External RC input pin
P57/TC3/PDO	P57	ST	CMOS	Bidirectional I/O pin
	TC3	ST	CMOS	Timer 3 clock input
	PDO			Programmable divider output
P60//INT	P60	ST	CMOS	Bidirectional I/O pin with programmable pull-down, open-drain, pull-high and pin change wakeup.
	/INT	ST		External interrupt pin
P61~P63	P61~P63	ST	CMOS	Bidirectional I/O pin with programmable pull-down, open-drain, pull-high and pin change wakeup.
P64~P65	P64~P65	ST	CMOS	Bidirectional I/O pin with programmable open-drain, pull-high and pin change wakeup.
P80/CO2	P80	ST	CMOS	Bidirectional I/O pin
	CO2		CMOS	Output of Comparator 2
P81/CIN2+	P81	ST	CMOS	Bidirectional I/O pin
	CIN2+	AN		Non-inverting end of Comparator 2
(DATA)	(DATA)	ST		Data pin for Writer programming

(Continuation)

Name	Function	Input Type	Output Type	Description
P82/CIN2-	P82	ST	CMOS	Bidirectional I/O pin
	CIN2-	AN		Inverting end of Comparator 2
(CLK)	(CLK)	ST	CMOS	Clock pin for Writer programming
P83/RESET	P83	ST	CMOS	Bidirectional I/O pin
	/RESET	ST		Internal pull-high reset pin
(/RESET)	(/RESET)	ST	CMOS	/RESET pin for Writer programming
VDD	VDD	Power	-	Power
VSS	VSS	Power	-	Ground

Legend: **ST**: Schmitt Trigger input

XTAL: oscillation pin for crystal/ resonator

AN: analog pin,

CMOS: CMOS output

5 Block Diagram

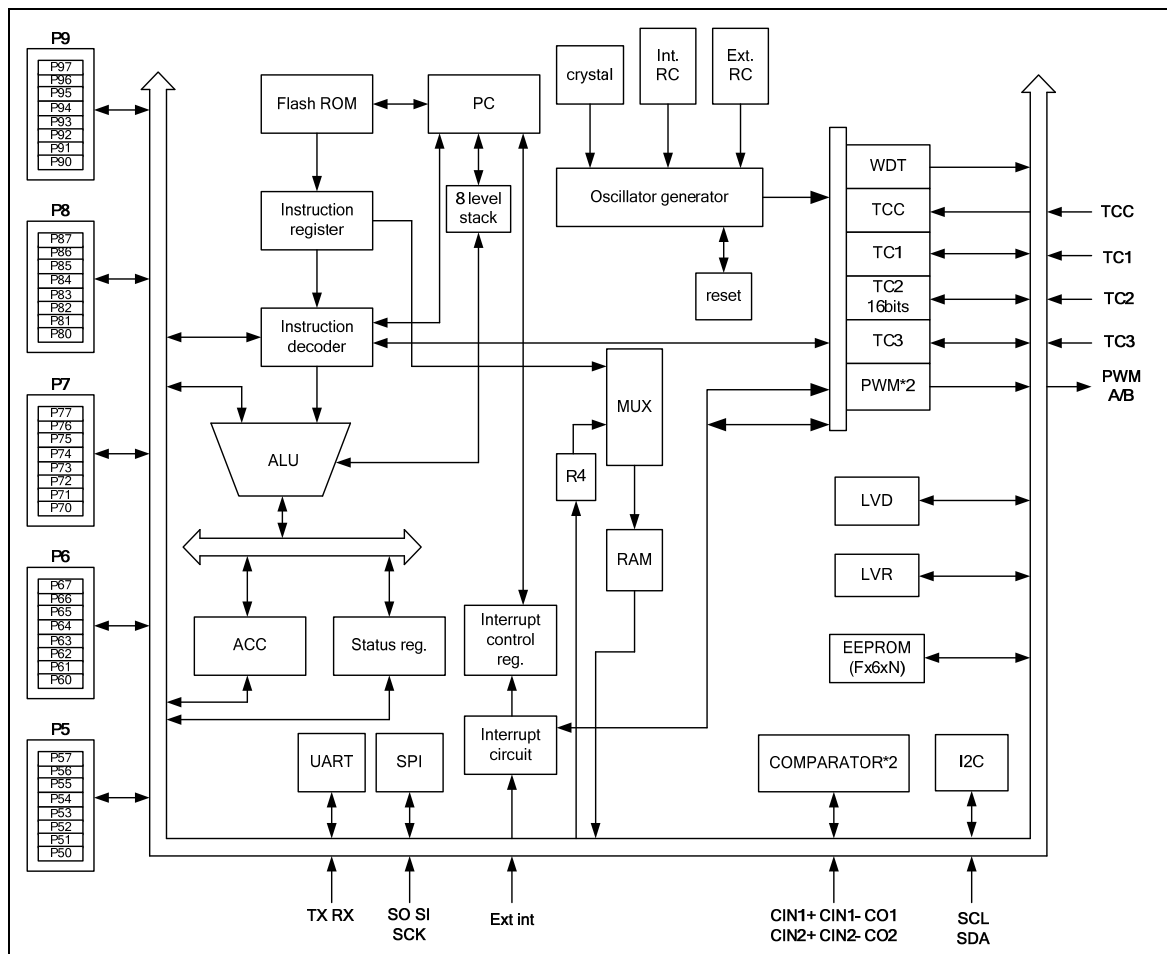

Figure 5-1 Functional Block Diagram

6 Functional Description

6.1 Operational Registers (for EM78F644/642/641/544/542/541N Series only)

6.1.1 R0 (Indirect Addressing Register)

R0 is not a physically implemented register. It is used as an indirect addressing pointer. Any instruction that uses R0 as a pointer actually accesses data pointed by the RAM Select Register (R4).

6.1.2 R1 (Timer Clock/Counter)

R1 is incremented by an external signal edge, which is defined by the TE bit (CONT-4) through the TCC pin, or by the instruction cycle clock. It is writable and readable as any other registers. It is defined by resetting PSTE (CONT-3).

The prescaler is assigned to TCC, if the PSTE bit (CONT-3) is reset. The content of the prescaler counter is cleared only when the TCC register is written with a value.

6.1.3 R2 (Program Counter and Stack)

- Depending on the device type, R2 and hardware stack are 12-bit wide. The structure is depicted in Figure 6-1a.
- The configuration structure generates 4K×13 bits on-chip Flash ROM addresses to the relative programming instruction codes. One program page is 1024 words long.
- R2 is set as all "0"s when under a reset condition.
- "JMP" instruction allows direct loading of the lower 10 program counter bits. Thus, "JMP" allows the PC to go to any location within a page.
- "CALL" instruction loads the lower 10 bits of the PC, and PC+1 are pushed onto the stack. Thus, the subroutine entry address can be located anywhere within a page.
- "LJMP" instruction allows direct loading of the program counter bits (A0~A11). Therefore, "LJMP" allows the PC to jump to any location within 4K (2^{12}).
- "LCALL" instruction loads the program counter bits (A0 ~A11), and PC+1 are pushed onto the stack. Thus, the subroutine entry address can be located anywhere within 4K (2^{12}).
- "RET" ("RETL k", "RETI") instruction loads the program counter with the contents of the top-level stack.

- "ADD R2, A" allows a relative address to be added to the current PC, and the ninth and above bits of the PC will increase progressively.
- "MOV R2, A" allows loading an address from the "A" register to the lower 8 bits of the PC, and the ninth and tenth bits of the PC remain unchanged.
- Any instruction except "ADD R2, A" that is written to R2 (e.g., "MOV R2, A", "BC R2, 6") will cause the ninth bit and the tenth bit (A8~A9) of the PC to remain unchanged.
- All instructions are single instruction cycle (fclk/2, fclk/4, fclk/8 or fclk/16) except for instructions that would change the contents of R2 and "LCALL", "LJMP", "TBRD" instructions. The "LCALL", "LJMP" and "TBRD" instructions need two instructions cycle.

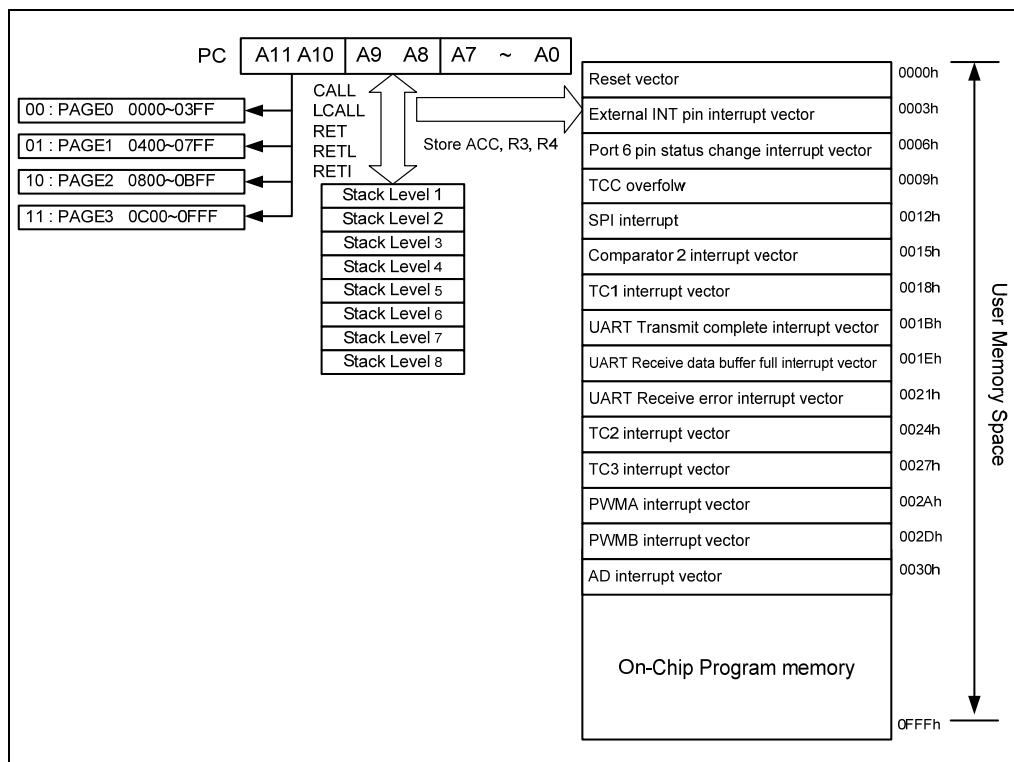

Figure 6-1 Program Counter Organization

■ Data Memory Configuration

Address	Register Bank 0	Register Bank 1	Register Bank 2	Register Bank 3	Control Register
01	R1 (TCC Buffer)				
02	R2 (PC)				
03	R3 (STATUS)				
04	R4 (RSR, bank select)	R4(7,6) (0,1)	(1,0)	(1,1)	
05	R5 (Port 5 I/O data)	R5 (Timer 1 Control)	R5 (Reserved)	R5 (Timer A and Timer B control register)	IOC5 (Port 5 I/O control)
06	R6 (Port 6 I/O data)	R6 (Timer 1 data Buffer A)	R6 (Reserved)	R6 (TBHP: Table Point Register)	IOC6 (Port 6 I/O control)
07	R7 (Port 7 I/O data)	R7 (Timer 1 data Buffer B)	R7 (Reserved)	R7 (Comparator 2 & PWM A/B control register)	IOC7 (Port 7 I/O control)
08	R8 (Port 8 I/O data)	R8 (Timer 2 Control)	R8 (Reserved)	R8 (PWMA/B lower 2-bits of period & duty control register)	IOC8 (Port 8 I/O control)
09	R9 (TBLP: Table Point Register)	R9 (Timer 2 High byte data buffer)	R9 (Reserved)	R9 (PRDA:PWMA period)	IOC9 (Reserved)
0A	RA (Wake control Register)	RA (Timer 2 Low byte data buffer)	RA (UART Control 1)	RA (DTAL:Duty cycle of PWMA)	IOCA (WDT control)
0B	RB (EEPROM control Register)	RB (SPI Status)	RB (UART Control 2)	RB (PRDB:PWMB period)	IOCB (Pull Down Control 2)
0C	RC (EEPROM address Register)	RC (SPI Control)	RC (UART Status)	RC (DTBL:Duty cycle of PWMB)	IOCC (Open Drain Control 1)
0D	RD (EEPROM data Register)	RD (SPI Read Buffer)	RD (UART_RD data buffer)	RD (Timer 3 Control)	IOCD (Pull High Control 2)
0E	RE (Mode Select Register)	RE (SPI Write Buffer)	RE (UART_TD data buffer)	RE (Timer 3 data buffer)	IOCE (Interrupt Mask 2)
0F	RF (Interrupt Status Flag 1)	RF (Interrupt Status Flag 2)	RF (Pull High Control 1)	RF (Pull Down Control 1)	IOCF (Interrupt Mask 1)
10 : 1F	16-Byte Common Register				
20 : 3F	Bank 0 32x8	Bank 1 32x8	Bank 2 32x8	Bank 3 32x8	

Figure 6-1b Data Memory Configuration



6.1.4 R3 (Status Register)

Bit 7	Bit 6	Bit 5	Bit 4	Bit 3	Bit 2	Bit 1	Bit 0
-	-	-	T	P	Z	DC	C

Bits 7 ~ 5: Not used, set to "0" all the time.

Bit 4 (T): Time-out bit

Set to "1" with the "SLEP" and "WDTC" commands, or during power up and reset to "0" by WDT time-out.

Bit 3 (P): Power down bit

Set to "1" during power-on or by a "WDTC" command and reset to "0" by a "SLEP" command.

Bit 2 (Z): Zero flag

Set to "1" if the result of an arithmetic or logic operation is zero.

Bit 1 (DC): Auxiliary carry flag

Bit 0 (C): Carry flag

6.1.5 R4 (RAM Select Register)

Bits 7 ~ 6: Used to select Bank 0 ~ Bank 3

NOTE

- For F642/542N, Bit 7 is unused. Set to "0" all the time.
- For F641/541N, Bit 7 ~ Bit 6 are unused. Set to "0" all the time.

Bits 5 ~ 0: Used to select registers (Address: 00~3F) in indirect addressing mode.

See the data Memory Configuration in Figure 6-1b.

6.1.6 Bank 0 R5 (Port 5)

Bit 7	Bit 6	Bit 5	Bit 4	Bit 3	Bit 2	Bit 1	Bit 0
P57	P56	P55	P54	P53	P52	P51	P50

Bit 7 ~ 0 (P57 ~ P50): 8-bit Port 5 I/O data register

NOTE

- For F642/542N, Bit 6, Bit 3 ~ Bit 1 are unused. Set to "0" all the time.
- For F641/541N, Bit 6, Bit 3 ~ Bit 1 are unused. Set to "0" all the time.

User can use the IOC5 register to define each bit as input or output.

6.1.7 Bank 0 R6 (Port 6)

Bit 7	Bit 6	Bit 5	Bit 4	Bit 3	Bit 2	Bit 1	Bit 0
P67	P66	P65	P64	P63	P62	P61	P60

Bit 7 ~ 0 (P67 ~ P60): 8-bit Port 6 I/O data register

NOTE
For F641/541N, Bit 7 and Bit 6 are unused. Set to "0" all the time.

User can use the IOC6 register to define each bit as input or output.

6.1.8 Bank 0 R7 (Port 7)

Bit 7	Bit 6	Bit 5	Bit 4	Bit 3	Bit 2	Bit 1	Bit 0
P77	P76	P75	P74	P73	P72	-	-

Bits 7 ~ 2 (P77 ~ P72): 6-bit Port 7 I/O data register

Bits 1 ~ 0: Not used, set to "0" all the time.

NOTE
<ul style="list-style-type: none"> ■ For F642/542N, Bit 6 and Bit 5, Bit 3 ~ Bit 0 are unused. Set to "0" all the time. ■ For F641/541N, Bit 7 ~ Bit 0 are unused. Set to "0" all the time.

User can use the IOC7 register to define each bit as input or output.

6.1.9 Bank 0 R8 (Port 8)

Bit 7	Bit 6	Bit 5	Bit 4	Bit 3	Bit 2	Bit 1	Bit 0
-	-	-	-	P83	P82	P81	P80

Bits 3 ~ 0 (P83 ~ P80): 4-bit Port 8 I/O data register

NOTE
For F644/544N, Bit 3 is unused. Set to "0" all the time.

User can use the IOC8 register to define each bit as input or output.

6.1.10 Bank 0 R9 (TBLP: Table Point Register for Instruction TBRD)

Bit 7	Bit 6	Bit 5	Bit 4	Bit 3	Bit 2	Bit 1	Bit 0
RBit7	RBit6	RBit5	RBit4	RBit3	RBit2	RBit1	RBit0

Bits 7 ~ 0: This is the least 8 significant bits of address for program code.

NOTE
<ul style="list-style-type: none"> ■ Bank 0 R9 overflow will carry to Bank 3 R6. ■ Bank 0 R9 underflow will borrow from Bank 3 R6.

6.1.11 Bank 0 RA (Wake-up Control Register)

Bit 7	Bit 6	Bit 5	Bit 4	Bit 3	Bit 2	Bit 1	Bit 0
CMP2WE	ICWE	-	EXWE	SPIWE	-	-	-

Bit 7 (CMP2WE): Comparator 2 wake-up enable bit

0: Disable Comparator 2 Wake-up

1: Enable Comparator 2 Wake-up

When the Comparator 2 Output Status Change is used to enter an interrupt vector or to Wake-up the IC from Sleep, the CMP2WE bit must be set to "Enable".

Bit 6 (ICWE): Port 6 input status change wake-up enable bit

0: Disable Port 6 input status change Wake-up

1: Enable Port 6 input status change Wake-up

Bit 5: Not used, set to "0" all the time

Bit 4 (EXWE): External /INT wake-up enable bit

0: Disable External /INT pin Wake-up

1: Enable External /INT pin Wake-up

Bit 3 (SPIWE): SPI Wake-up enable bit when SPI acts as Slave device

0: Disable SPI Wake-up when SPI acts as Slave device

1: Enable SPI Wake-up when SPI acts as Slave device

NOTE

- F642/542N, Bit 3 is unused. Set to "0" all the time.
- For F641/541N, Bit 3 is unused. Set to "0" all the time.

Bits 2 ~ 0: Not used, set to "0" all the time.

6.1.12 Bank 0 RB (EEPROM Control Register)

Bit 7	Bit 6	Bit 5	Bit 4	Bit 3	Bit 2	Bit 1	Bit 0
RD	WR	EEWE	EEDF	EEPC	-	-	-

Bit 7 (RD): Read control register

0: Disable EEPROM read execution

1: Read EEPROM contents (RD can be set by software. RD is cleared by hardware after Read instruction is completed).

Bit 6 (WR): Write control register

0: Write cycle to the EEPROM is completed.

1: Initiate a write cycle (WR can be set by software. WR is cleared by hardware after Write cycle is completed).

Bit 5 (EWE): EEPROM Write Enable bit

0: Prohibit write to the EEPROM

1: Allows EEPROM write cycles

Bit 4 (EEDF): EEPROM Detect Flag

0: Write cycle is completed

1: Write cycle is unfinished

Bit 3 (EEPC): EEPROM power-down control bit

0: Switch OFF the EEPROM

1: Switch ON the EEPROM

Bits 2 ~ 0: Not used, set to "0" all the time.

NOTE

EM78F548/544/542/541N series ICs do **not** support EEPROM function. Therefore, the corresponding control registers (Bank 0 RB~RD) are reserved.

6.1.13 Bank 0 RC (256 Bytes EEPROM Address)

Bit 7	Bit 6	Bit 5	Bit 4	Bit 3	Bit 2	Bit 1	Bit 0
EE_A7	EE_A6	EE_A5	EE_A4	EE_A3	EE_A2	EE_A1	EE_A0

Bits 7 ~ 0: 256 bytes EEPROM address

NOTE

- EM78F548/544/542/541N series ICs do **not** support EEPROM function. Therefore, the corresponding control registers (Bank 0 RB~RD) are reserved.
- For F642/542N, Bit 7 is unused. Set to "0" all the time.
- For F641/541N, Bit 7 is unused. Set to "0" all the time.

6.1.14 Bank 0 RD (256 Bytes EEPROM Data)

Bit 7	Bit 6	Bit 5	Bit 4	Bit 3	Bit 2	Bit 1	Bit 0
EE_D7	EE_D6	EE_D5	EE_D4	EE_D3	EE_D2	EE_D1	EE_D0

Bits 7 ~ 0: 256 bytes EEPROM data

NOTE

EM78F548/544/542/541N series ICs do **not** support EEPROM function. Therefore, the corresponding control registers (Bank0 RB~RD) are reserved.

6.1.15 Bank 0 RE (Mode Select Register)

Bit 7	Bit 6	Bit 5	Bit 4	Bit 3	Bit 2	Bit 1	Bit 0
-	TIMERSC	CPUS	IDLE	-	-	-	-

Bit 7: Not used, set to “0” all the time

Bit 6 (TIMERSC): TCC, TC1, TC2, TC3, Timer A and Timer B clock source select

0: Fs is used as Fc

1: Fm is used as Fc

Bit 5 (CPUS): CPU Oscillator Source Select.

0: Fs: Sub frequency for WDT internal RC time base

1: Fm: Main-oscillator clock

When CPUS=0, the CPU oscillator selects the Sub-oscillator, and the Main oscillator is stopped.

Bit 4 (IDLE): Idle Mode Enable Bit.

0: IDLE="0" + SLEP instruction → Sleep mode

1: IDLE="1" + SLEP instruction → Idle mode

■ CPU Operation Mode

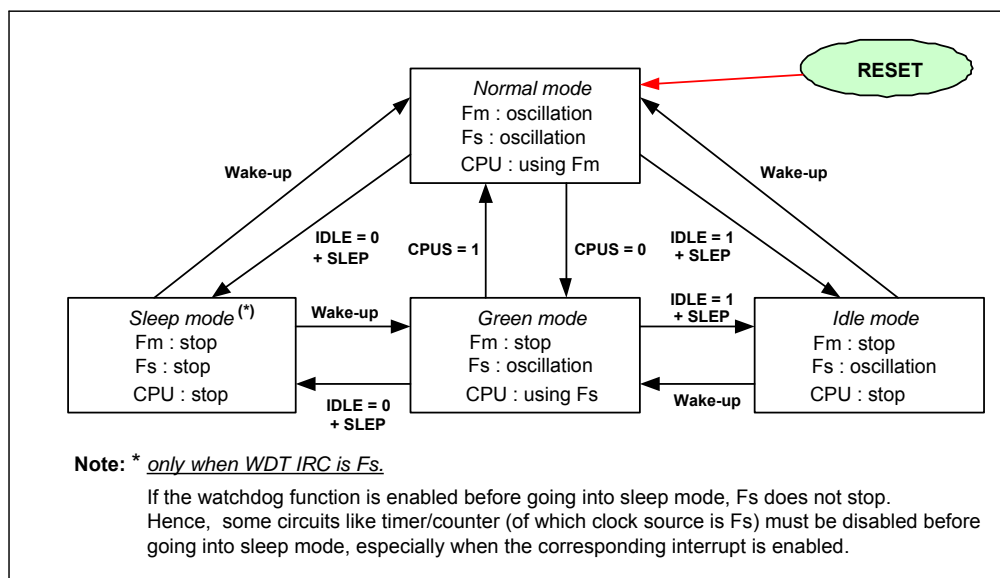

Figure 6-2 CPU Operation Mode Block Diagram

Oscillator (Normal Mode Source)	CPU Mode Status	Oscillator Stable Time (S) ¹	Count from Normal/Green (CLK) ²
Crystal ; 1M ~ 16 MHz	Sleep/Idle → Normal	0.5 ms ~ 2 ms	254 CLK
	Green → Normal		254 CLK
	Sleep/Idle → Green	< 100 μs	32 CLK
ERC ; 3.5 MHz	Sleep/Idle → Normal	< 5 μs	32 CLK
	Green → Normal		
	Sleep/Idle → Green	< 100 μs	
IRC ; 455K, 4M, 8M, 16 MHz	Sleep/Idle → Normal	< 2 μs	32 CLK
	Green → Normal		
	Sleep/Idle → Green	< 100 μs	

¹ The oscillator stable time depends on the oscillator characteristics

² After the oscillator has stabilized, the CPU will count 254/32 CLK in Normal/Green mode and continue to work in Normal/Green mode.

Ex 1: The 4 MHz IRC Wakes-up from Sleep mode to Normal mode. The total Wake-up time is 2 μs + 32 CLK @ 4 MHz

Ex 2: The 4 MHz IRC Wakes-up from Sleep mode to Green mode. The total wake-up time is 100 μs + 32 CLK @ 16kHz

Bits 3 ~ 0: Not used, set to “0” all the time.

6.1.16 Bank 0 RF (Interrupt Status Register 1)

Bit 7	Bit 6	Bit 5	Bit 4	Bit 3	Bit 2	Bit 1	Bit 0
-	-	SPIIF	PWMBIF	PWMAIF	EXIF	ICIF	TCIF

Note: Set to “1” to enable Interrupt Request

“0” to disable interrupt execution

Bits 7 ~ 6: Not used, set to “0” all the time.

Bit 5 (SPIIF): SPI mode Interrupt flag. Flag is cleared by software.

Bit 4 (PWMBIF): PWMB (Pulse Width Modulation) Interrupt flag
Set when a selected period is reached. Reset by software.

Bit 3 (PWMAIF): PWMA (Pulse Width Modulation) interrupt flag.
Set when a selected period is reached. Reset by software.

NOTE

- For F642/542N, Bit 5 ~ Bit 3 are unused. Set to “0” all the time.
- For F641/541N, Bit 5 ~ Bit 3 are unused. Set to “0” all the time

Bit 2 (EXIF): External interrupt flag. Set by a falling edge on /INT pin, reset by software.

Bit 1 (ICIF): Port 6 input status change interrupt flag. Set when Port 6 input changes, reset by software.

Bit 0 (TCIF): TCC overflow interrupt flag. Set when TCC overflows, reset by software.

NOTE

- *RF can be cleared by instruction but cannot be set.*
- *IOCF is the interrupt mask register.*
- *The result of reading RF is the "logic AND" of RF and IOCF.*

6.1.17 R10 ~ R3F

These are all 8-bit general-purpose registers.

6.1.18 Bank 1 R5 TC1CR (Timer 1 Control)

Bit 7	Bit 6	Bit 5	Bit 4	Bit 3	Bit 2	Bit 1	Bit 0
TC1CAP	TC1S	TC1CK1	TC1CK0	TC1M	TC1ES	-	-

NOTE

For F641/541N, this register is reserved.

Bit 7 (TC1CAP): Software capture control

0: Disable software capture

1: Enable software capture

Bit 6 (TC1S): Timer/Counter 1 start control

0: Stop and clear the counter

1: Start Timer/Counter 1

Bit 5~Bit 4 (TC1CK1~TC1CK0): Timer/Counter 1 clock source selection

TC1CK1	TC1CK0	Clock Source	Resolution (4 MHz)	Max. Time (4 MHz)	Resolution (16kHz)	Max. Time (16kHz)
		Normal, Idle	Fc=4M	Fc=4M	Fc=16K	Fc=16K
0	0	Fc/2 ¹²	1024 μs	262144 μs	256 ms	65536 ms
0	1	Fc/2 ¹⁰	256 μs	65536 μs	64 ms	16384 ms
1	0	Fc/2 ⁷	32 μs	8192 μs	8 ms	2048 ms
1	1	External clock (TC1 pin)	-	-	-	-

Bit 3 (TC1M): Timer/Counter 1 mode select

0: Timer/Counter 1 mode

1: Capture mode

- Bit 2 (TC1ES):** TC1 signal edge
0: Increment if the transition from low to high (rising edge) takes place on the TC1 pin.
1: Increment if the transition from high to low (falling edge) takes place on TC1 pin.
- Bits 1 ~ 0:** Not used, set to "0" all the time.

■ **Timer/Counter 1 Configuration**

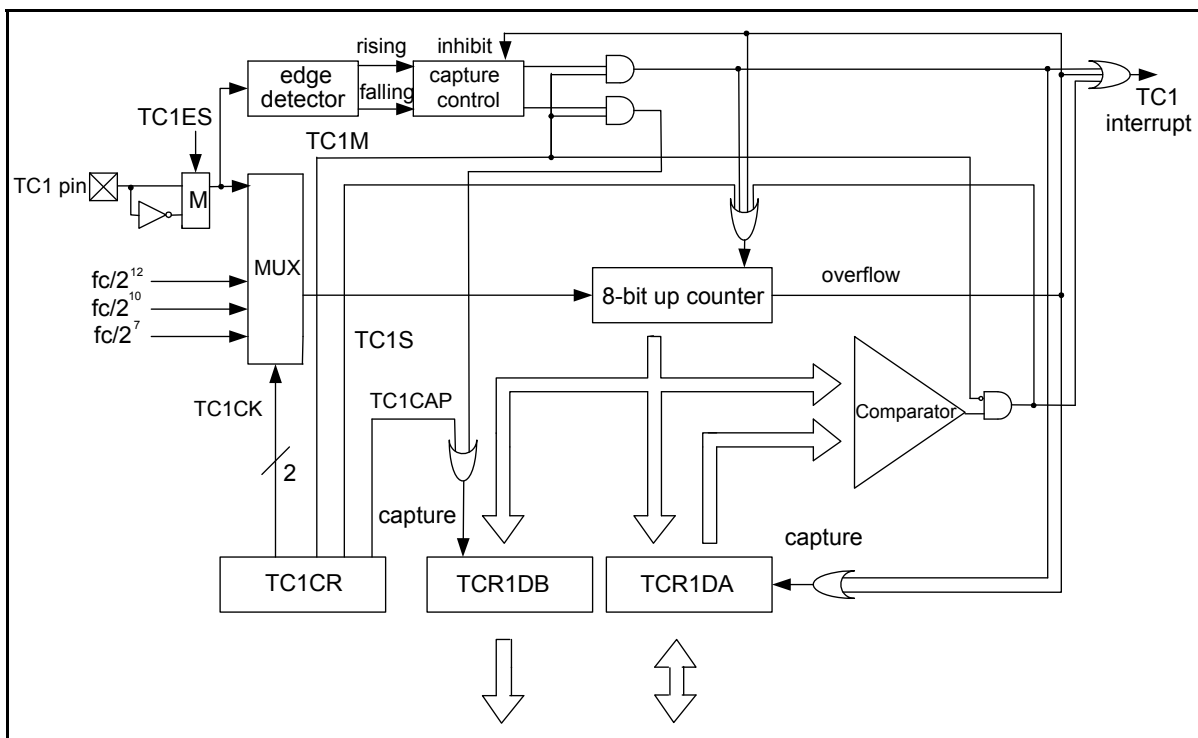

Figure 6-3a Timer/Counter 1 Configuration Block Diagram

In Timer mode, counting up is performed using the internal clock. When the contents of the up-counter matched the TCR1DA, then interrupt is generated and the counter is cleared. Counting up resumes after the counter is cleared. The current contents of the up-counter are loaded into TCR1DB by setting TC1CAP to "1" and the TC1CAP is automatically cleared to "0" after capture is completed.

In Counter mode, counting up is performed using the external clock input pin (TC1 pin) and either rising or falling edge can be selected by TC1ES, **but both edges cannot be used**. When the contents of the up-counter matched the TCR1DA, then interrupt is generated and the counter is cleared. Counting up resumes after the counter is cleared. The current contents of the up-counter are loaded into the TCR1DB by setting TC1CAP to "1" and the TC1CAP is automatically cleared to "0" after capture is completed.

In **Capture mode**, the pulse width, period and duty of the TC1 input pin are measured under this mode to decode the remote control signal. The counter is set as free running by the internal clock. On a rising (falling) edge of TC1 pin input, the contents of the counter is loaded into TCR1DA, then the counter is cleared and interrupt is generated. On a falling (rising) edge of the TC1 pin input, the contents of the counter are loaded into TCR1DB. At the next rising edge of the TC1 pin input while the counter is still counting, the contents of the counter are loaded into TCR1DA. Then, the counter is cleared and interrupt is generated again. If an overflow occurs before an edge is detected, the FFH is loaded into TCR1DA and the overflow interrupt is generated. During interrupt processing, user can determine whether an overflow has occurred by checking if the TCR1DA value is FFH. After an interrupt (capture to TCR1DA or overflow detection) is generated, capture and overflow detection are halted until TCR1DA is read out.

■ **Capture Mode Timing**

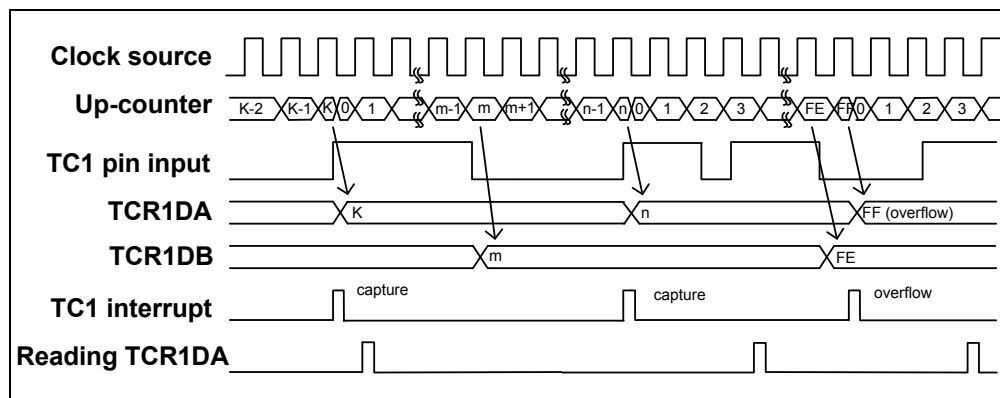

Figure 6-3b Capture Mode Timing Diagram

6.1.19 Bank 1 R6 TCR1DA (Timer 1 Data Buffer A)

Bit 7	Bit 6	Bit 5	Bit 4	Bit 3	Bit 2	Bit 1	Bit 0
TCR1DA7	TCR1DA6	TCR1DA5	TCR1DA4	TCR1DA3	TCR1DA2	TCR1DA1	TCR1DA0

Bit 7 ~ Bit 0 (TCR1DA7 ~ TCR1DA0): Data buffer of 8-bit Timer/Counter 1.

NOTE
For F641/541N, this register is reserved.

6.1.20 Bank 1 R7 TCR1DB (Timer 1 Data Buffer B)

Bit 7	Bit 6	Bit 5	Bit 4	Bit 3	Bit 2	Bit 1	Bit 0
TCR1DB7	TCR1DB6	TCR1DB5	TCR1DB4	TCR1DB3	TCR1DB2	TCR1DB1	TCR1DB0

Bit 7 ~ Bit 0 (TCR1DB7 ~ TCR1DB0): Data buffer of 8-bit Timer/Counter 1.

NOTE
For F641/541N, this register is reserved.

6.1.21 Bank 1 R8 TC2CR (Timer 2 Control)

Bit 7	Bit 6	Bit 5	Bit 4	Bit 3	Bit 2	Bit 1	Bit 0
RCM1	RCM0	TC2ES	TC2M	TC2S	TC2CK2	TC2CK1	TC2CK0

Bits 7 ~ 6 (RCM1 ~ RCM0): IRC mode select bits. The Bank 1 R8<7,6> is enabled when Word 1<12> COBS0 = "1".

Writer Trim IRC	Bank 1 R8<7,6>		Frequency	Operating Voltage Range	Stable Time
	RCM1	RCM0			
4 MHz	0	0	4 MHz \pm 2.5%	2.2V ~ 5.5V	< 5 μ s
	0	1	16 MHz \pm 10%	4.5V ~ 5.5V	< 1.5 μ s
	1	0	8 MHz \pm 10%	3.0V ~ 5.5V	< 3 μ s
	1	1	455kHz \pm 10%	2.2V ~ 5.5V	< 50 μ s
16 MHz	0	0	4 MHz \pm 10%	2.2V ~ 5.5V	< 6 μ s
	0	1	16 MHz \pm 2.5%	4.5V ~ 5.5V	< 1.25 μ s
	1	0	8 MHz \pm 10%	3.0V ~ 5.5V	< 3 μ s
	1	1	455kHz \pm 10%	2.2V ~ 5.5V	< 50 μ s
8 MHz	0	0	4 MHz \pm 10%	2.2V ~ 5.5V	< 6 μ s
	0	1	16 MHz \pm 10%	4.5V ~ 5.5V	< 1.5 μ s
	1	0	8 MHz \pm 2.5%	3.0V ~ 5.5V	< 2.5 μ s
	1	1	455kHz \pm 10%	2.2V ~ 5.5V	< 50 μ s
455kHz	0	0	4 MHz \pm 10%	2.2V ~ 5.5V	< 6 μ s
	0	1	16 MHz \pm 10%	4.5V ~ 5.5V	< 1.5 μ s
	1	0	8 MHz \pm 10%	3.0V ~ 5.5V	< 3 μ s
	1	1	455kHz \pm 2.5%	2.2V ~ 5.5V	< 45 μ s

NOTE

- The initial values of Bank 1 R8<7,6> will be kept the same as Word 1<3,2>.
- If the IRC frequency is changed from A-frequency to B-frequency, the MCU needs to wait for some time for it to work. The waiting time corresponds to the B-frequency.

Example:

1st Step When user selects the 4 MHz at the Writer, the initial values of Bank 1 R8<7,6> would be "00", the same as the value of Word 1<3,2>. If the MCU is free-running, it will work at 4 MHz \pm 2.5%. Refer to the table below.

Writer Trim IRC	Bank 1 R8<7,6>		Frequency	Operating Voltage Range	Stable Time
	RCM1	RCM0			
4 MHz	0	0	4 MHz \pm 2.5%	2.2V ~ 5.5V	< 5 μ s
	0	1	16 MHz \pm 10%	4.5V ~ 5.5V	< 1.5 μ s
	1	0	8 MHz \pm 10%	3.0V ~ 5.5V	< 3 μ s
	1	1	455kHz \pm 10%	2.2V ~ 5.5V	< 50 μ s

2nd Step If it is desired to set Bank 1 R8<7,6> = “01” while the MCU is working at 4 MHz \pm 2.5%, the MCU needs to hold for 1.5 μ s, then it will continue to work at 16 MHz \pm 10%.

Writer Trim IRC	Bank 1 R8<7,6>		Frequency	Operating Voltage Range	Stable Time
	RCM1	RCM0			
4 MHz	0	0	4 MHz \pm 2.5%	2.2V ~ 5.5V	< 5 μ s
	0	1	16 MHz \pm 10%	4.5V ~ 5.5V	< 1.5 μ s
	1	0	8 MHz \pm 10%	3.0V ~ 5.5V	< 3 μ s
	1	1	455kHz \pm 10%	2.2V ~ 5.5V	< 50 μ s

3rd Step If it is desired to set Bank 1 R8<7,6> = “11” while the MCU is working at 16 MHz \pm 10%, the MCU needs to hold for 50 μ s, then it will continue to work at 455kHz \pm 10%.

Writer Trim IRC	Bank 1 R8<7,6>		Frequency	Operating Voltage Range	Stable Time
	RCM1	RCM0			
4 MHz	0	0	4 MHz \pm 2.5%	2.2V ~ 5.5V	< 5 μ s
	0	1	16 MHz \pm 10%	4.5V ~ 5.5V	< 1.5 μ s
	1	0	8 MHz \pm 10%	3.0V ~ 5.5V	< 3 μ s
	1	1	455kHz \pm 10%	2.2V ~ 5.5V	< 50 μ s

4th Step If it is desired to set Bank 1 R8<7,6> = “00” while the MCU is working at 455kHz \pm 10%, the MCU needs to hold for 5 μ s, then it will continue to work at 4 MHz \pm 2.5%.

Writer Trim IRC	Bank 1 R8<7,6>		Frequency	Operating Voltage Range	Stable Time
	RCM1	RCM0			
4 MHz	0	0	4 MHz \pm 2.5%	2.2V ~ 5.5V	< 5 μ s
	0	1	16 MHz \pm 10%	4.5V ~ 5.5V	< 1.5 μ s
	1	0	8 MHz \pm 10%	3.0V ~ 5.5V	< 3 μ s
	1	1	455kHz \pm 10%	2.2V ~ 5.5V	< 50 μ s

Bit 5 (TC2ES) TC2 signal edge

0: Increment if a transition from low to high (rising edge) takes place on the TC2 pin.

1: increment if a transition from high to low (falling edge) takes place on the TC2 pin.

Bit 4 (TC2M): Timer/Counter 2 mode select

0: Timer/counter mode

1: Window mode

NOTE

For F642/542N, Bit 5 ~ Bit 4 are unused. Set to “0” all the time.

Bit 3 (TC2S): Timer/Counter 2 start control

0: Stop and clear the counter

1: Start Timer/Counter 2

Bit 2~Bit 0 (TC2CK2~TC2CK0): Timer/Counter 2 clock source select

TC2CK2	TC2CK1	TC2CK0	Clock Source	Resolution	Max. Time	Resolution	Max. Time
			Normal, Idle	Fc=4M	Fc=4M	Fc=16K	Fc=16K
0	0	0	$Fc/2^{23}$	2.1 sec	38.2 hr	524.3 s	9544 hr
0	0	1	$Fc/2^{13}$	2.048 ms	134.22 sec	512 ms	33554.432 s
0	1	0	$Fc/2^8$	64 μ s	4.194 sec	16 ms	1048.576 s
0	1	1	$Fc/2^3$	2 μ s	131.072 ms	0.5 ms	32768 ms
1	0	0	Fc	250 ns	16.384 ms	0.0625 ms	4096 ms
1	0	1	–	–	–	–	–
1	1	0	–	–	–	–	–
1	1	1	External clock (TC2 pin)	–	–	–	–

NOTE

For F641/541N, Bit 7 ~ Bit 6 cannot be set as "11" Bit 5 ~ Bit 0 are unused and set to "0" all the time.

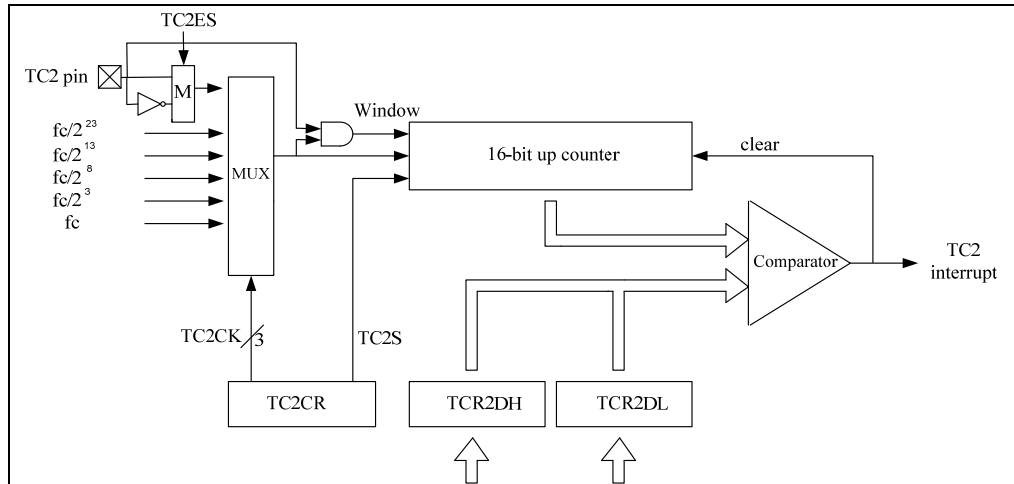

Figure 6-4a Timer/Counter 2 Configuration Block Diagram

In Timer mode, counting up is performed using internal clock. When the contents of the up-counter match the TCR2 (TCR2DH+TCR2DL), interrupt is then generated and the counter is cleared. Counting up resumes after the counter is cleared.

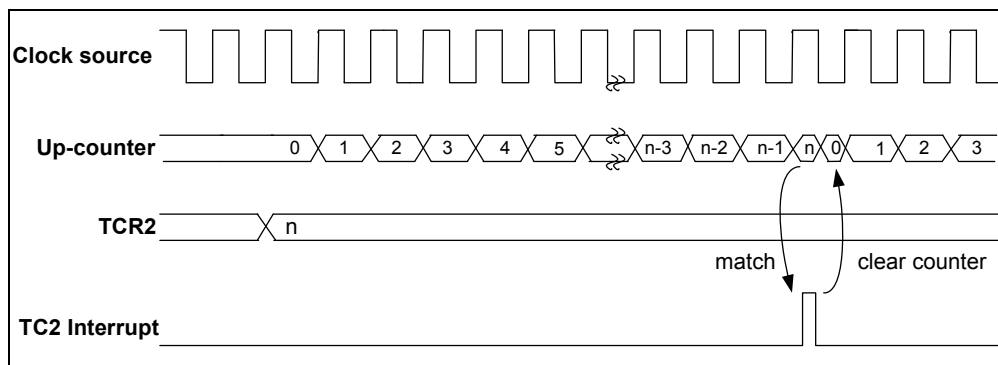

Figure 6-4b Timer Mode Timing Diagram

In Counter mode, counting up is performed using external clock input pin (TC2) and either rising or falling can be selected by setting TC2ES. When the contents of the up-counter match the TCR2 (TCR2DH+TCR2DL), then interrupt is generated and the counter is cleared. Counting up resumes after the counter is cleared.

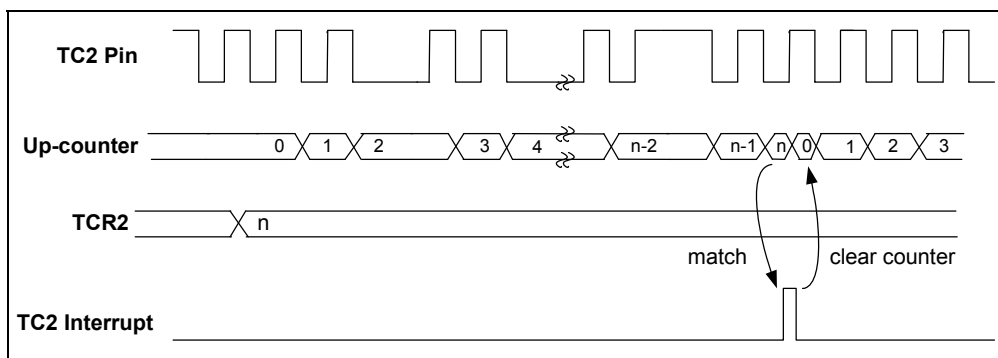

Figure 6-4c Counter Mode Timing Diagram

In Window mode, counting up is performed on a rising edge of the pulse that is logical AND of an internal clock and the TC2 pin (window pulse). When the contents of up-counter match with the TCR2 (TCR2DH+TCR2DL), then interrupt is generated and the counter is cleared. **The frequency (window pulse) must be slower than the selected internal clock.**

In Writing to the TCR2DL, comparison is inhibited until TCR2DH is written.

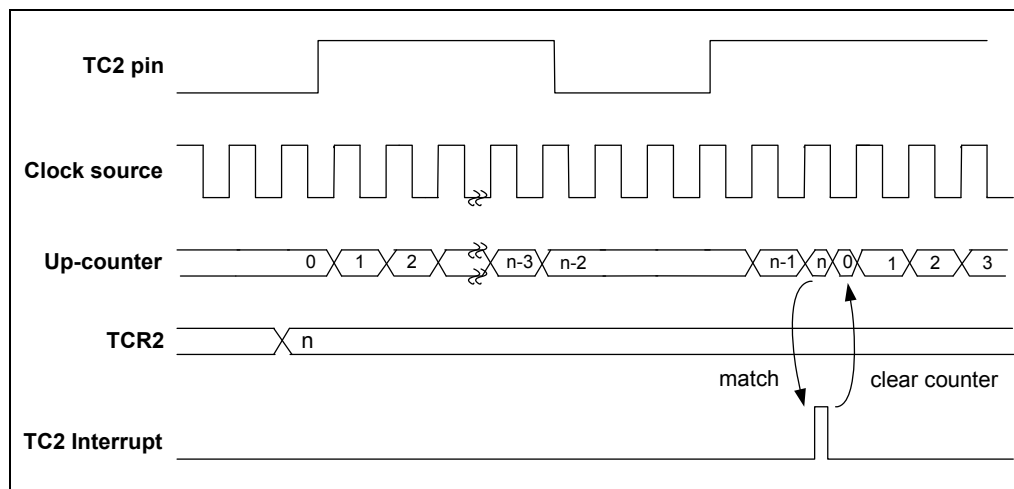

Figure 6-4d Window Mode Timing Diagram

6.1.22 Bank 1 R9 TC2DH (Timer 2 High Byte Data Buffer)

Bit 7	Bit 6	Bit 5	Bit 4	Bit 3	Bit 2	Bit 1	Bit 0
TC2D15	TC2D14	TC2D13	TC2D12	TC2D11	TC2D10	TC2D9	TC2D8

Bit 7 ~ Bit 0 (TCR2D15 ~ TCR2D8): High byte data buffer of 16-bit Timer/Counter 2

NOTE
For F641/541N, this register is reserved.

6.1.23 Bank 1 RA TC2DL (Timer 2 Low Byte Data Buffer)

Bit 7	Bit 6	Bit 5	Bit 4	Bit 3	Bit 2	Bit 1	Bit 0
TC2D7	TC2D6	TC2D5	TC2D4	TC2D3	TC2D2	TC2D1	TC2D0

Bit 7 ~ Bit 0 (TC2D7 ~ TC2D0): Low byte data buffer of 16-bit Timer/Counter 2

NOTE
For F641/541N, this register is reserved.

6.1.24 Bank 1 RB SPIS (SPI Status Register)

Bit 7	Bit 6	Bit 5	Bit 4	Bit 3	Bit 2	Bit 1	Bit 0
DORD	TD1	TD0	-	OD3	OD4	-	RBF

NOTE
For F642/542N, F641/541N, this register is reserved.

Bit 7 (DORD): Data transmission order

0: Shift left (MSB first)

1: Shift right (LSB first)

Bit 6~Bit 5 (TD1 ~ TD0): SDO status output delay time options

TD1	TD0	Delay Time
0	0	8 CLK
0	1	16 CLK
1	0	24 CLK
1	1	32 CLK

Bit 4: Not used, set to “0” all the time.

Bit 3 (OD3): Open-Drain control bit

- 0: Open-drain disable for SDO
- 1: Open-drain enable for SDO

Bit 2 (OD4): Open-Drain control bit

- 0: Open-drain disable for SCK
- 1: Open-drain enable for SCK

Bit 1: Not used, set to “0” all the time

Bit 0 (RBF): Read Buffer Full flag

- 0: Receiving is not completed. SPIRB has not fully exchanged data.
- 1: Receiving completed; SPIRB has fully exchanged data.

6.1.25 Bank 1 RC SPIC (SPI Control Register)

Bit 7	Bit 6	Bit 5	Bit 4	Bit 3	Bit 2	Bit 1	Bit 0
CES	SPIE	SRO	SSE	SDOC	SBRS2	SBRS1	SBRS0

NOTE

For F642/542N, F641/541N, this register is reserved.

Bit 7 (CES): Clock Edge Select bit

- 0: Data shifts out on a rising edge, and shifts in on a falling edge. Data is on hold during low-level.
- 1: Data shifts out on a falling edge, and shifts in on a rising edge. Data is on hold during high-level.

Bit 6 (SPIE): SPI Enable bit

- 0: Disable SPI mode
- 1: Enable SPI mode

Bit 5 (SRO): SPI Read Overflow bit

0: No overflow

1: A new data is received while the previous data is still being held in the SPIRB register. Under this condition, the data in the SPI Shift register will be destroyed. To avoid setting this bit, users are required to read the SPIRB register although only transmission is implemented. This can only occur in Slave mode.

Bit 4 (SSE): SPI Shift Enable bit

0: Reset as soon as the shifting is completed and the next byte is ready to shift.

1: Start to shift, and keep at “1” while the current byte is still being transmitted.

This bit will reset to “0” at every 1-byte transmission by the hardware.

Bit 3 (SDOC): SDO output status control bit

0: After Serial data output, the SDO remains high.

1: After Serial data output, the SDO remains low.

Bit 2 ~ Bit 0 (SBR2 ~ SBR0): SPI Baud Rate Select bits

SBR2 (Bit 2)	SBR1 (Bit 1)	SBR0 (Bit 0)	Mode	Baud Rate
0	0	0	Master	Fosc/2
0	0	1	Master	Fosc/4
0	1	0	Master	Fosc/8
0	1	1	Master	Fosc/16
1	0	0	Master	Fosc/32
1	0	1	Master	Fosc/64
1	1	0	Slave	/SS enable
1	1	1	Slave	/SS disable

Note: Up to 2 MHz (maximum) bit frequency. If the system frequency (Fosc) operates at 8 MHz, we recommend choosing Fosc/4 as maximum baud rate option of SPI function

6.1.26 Bank 1 RD SPIRB (SPI Read Buffer)

Bit 7	Bit 6	Bit 5	Bit 4	Bit 3	Bit 2	Bit 1	Bit 0
SRB7	SRB6	SRB5	SRB4	SRB3	SRB2	SRB1	SRB0

Bit 7 ~ Bit 0 (SRB7 ~ SRB0): SPI Read data buffer

NOTE

For F642/542N, F641/541N, this register is reserved.

6.1.27 Bank 1 RE SPIWB (SPI Write Data Buffer)

Bit 7	Bit 6	Bit 5	Bit 4	Bit 3	Bit 2	Bit 1	Bit 0
SWB7	SWB6	SWB5	SWB4	SWB3	SWB2	SWB1	SWB0

Bit 7 ~ Bit 0 (SWB7 ~ SWB0): SPI Write data buffer

NOTE

For F642/542N, F641/541N, this register is reserved.

6.1.28 Bank 1 RF (Interrupt Status Register 2)

Bit 7	Bit 6	Bit 5	Bit 4	Bit 3	Bit 2	Bit 1	Bit 0
CMP2IF	-	TC3IF	TC2IF	TC1IF	UERRIF	RBFIF	TBEF

Bit 7 (CMP2IF): Comparator 2 Interrupt flag. Set when a change occurs in the Comparator 2 output. Reset by software.

Bit 6: Not used, set to "0" all the time.

Bit 5 (TC3IF): 8-bit Timer/Counter 3 Interrupt flag

Bit 4 (TC2IF): 16-bit Timer/Counter 2 Interrupt flag

Bit 3 (TC1IF): 8-bit Timer/Counter 1 Interrupt flag

Bit 2 (UERRIF): UART Receive Error Interrupt flag

Bit 1 (RBFIF): UART receive mode data buffer full interrupt flag

Bit 0 (TBEF): UART transmit mode data buffer empty interrupt flag

NOTE

- The Interrupt flag is automatically set by hardware. It must be cleared by software.
- For F642/542N, Bit 2 ~ Bit 0 are unused. Set to "0" all the time.
- For F641/541N, Bit 4 ~ Bit 0 are unused. Set to "0" all the time

6.1.29 Bank 2 RA URC1 (UART Control 1)

Bit 7	Bit 6	Bit 5	Bit 4	Bit 3	Bit 2	Bit 1	Bit 0
URTD8	UMODE1	UMODE0	BRATE2	BRATE1	BRATE0	UTBE	TXE

NOTE

For F642/542N, F641/541N, this register is reserved.

Bit 7 (URTD8): Transmission Data Bit 8

Bit 6 ~ Bit 5 (UMODE1 ~ UMODE0): UART mode select

UMODE1	UMODE0	UART Mode
0	0	Mode 1: 7-bit
0	1	Mode 1: 8-bit
1	0	Mode 1: 9-bit
1	1	Reserved

Bit 4 ~ Bit 2 (BRATE2 ~ BRATE0): Transmit Baud Rate select

BRATE2	BRATE1	BRATE0	Baud Rate	4 MHz	8 MHz
0	0	0	Fc/13	19200	38400
0	0	1	Fc/26	9600	19200
0	1	0	Fc/52	4800	9600
0	1	1	Fc/104	2400	4800
1	0	0	Fc/208	1200	2400
1	0	1	Fc/416	600	1200
1	1	0	TC3	–	–
1	1	1	Reserved		

Bit 1 (UTBE): UART transfer buffer empty flag. Set to “1” when transfer buffer is empty. Automatically reset to “0” when writing to the UR TD register. The UTBE bit will be cleared by hardware when transmission is enabled. The UTBE bit is read-only. Therefore, writing to the UR TD register is necessary when user wants to start shift transmission.

Bit 0 (TXE): Enable transmission

0: Disable

1: Enable

6.1.30 Bank 2 RB URC2 (UART Control 2)

Bit 7	Bit 6	Bit 5	Bit 4	Bit 3	Bit 2	Bit 1	Bit 0
-	-	SBIM1	SBIM0	UINVEN	-	-	-

NOTE

For F642/542N, F641/541N, this register is reserved.

Bits 7 ~ 6: Not used, set to “0” all the time.

Bit 5 ~ Bit 4 (SBIM1 ~ SBIM0): Serial bus interface operating mode select

SBIM1	SBIM0	Operating Mode
0	0	I/O mode
0	1	SPI mode
1	0	UART mode
1	1	Reserved



Bit 3 (UINVEN): Enable UART TXD and RXD port inverse output.

0: Disable TXD and RXD port inverse output

1: Enable TXD and RXD port inverse output

Bits 2 ~ 0: Not used, set to "0" all the time

6.1.31 Bank 2 RC URS (UART Status)

Bit 7	Bit 6	Bit 5	Bit 4	Bit 3	Bit 2	Bit 1	Bit 0
URRD8	EVEN	PRE	PRERR	OVERR	FMERR	URBF	RXE

NOTE

For F642/542N, F641/541N, this register is reserved.

Bit 7 (URRD8): Receiving Data Bit 8

Bit 6 (EVEN): Select parity check

0: Odd parity

1: Even parity

Bit 5 (PRE): Enable parity addition

0: Disable

1: Enable

Bit 4 (PRERR): Parity error flag. Set to "1" when parity error occurred.

Bit 3 (OVERR): Over running error flag. Set to "1" when an overrun error occurred.

Bit 2 (FMERR): Framing error flag. Set to "1" when framing error occurred.

NOTE

The Interrupt flag is automatically set by hardware. It must be cleared by software.

Bit 1 (URBF): UART read buffer full flag. Set to "1" when one character is received. Reset to 0 automatically when read from URS and URRD register.

The URBFB will be cleared by hardware when enabling receiving. The URBFB bit is read-only. Therefore, reading the URS register is necessary to avoid overrun error.

Bit 0 (RXE): Enable receiving

0: Disable

1: Enable

6.1.32 Bank 2 RD URRD (UART_RD Data Buffer)

Bit 7	Bit 6	Bit 5	Bit 4	Bit 3	Bit 2	Bit 1	Bit 0
URRD7	URRD6	URRD5	URRD4	URRD3	URRD2	URRD1	URRD0

Bits 7 ~ 0 (URRD7 ~ URRD0): UART receive data buffer. **Read only.**

NOTE

For F642/542N, F641/541N, this register is reserved.

6.1.33 Bank 2 RE URTD (UART_TD Data Buffer)

Bit 7	Bit 6	Bit 5	Bit 4	Bit 3	Bit 2	Bit 1	Bit 0
URTD7	URTD6	URTD5	URTD4	URTD3	URTD2	URTD1	URTD0

Bits 7 ~ 0 (URTD7 ~ URTD0): UART transmit data buffer. **Write only.**

NOTE

For F642/542N, F641/541N, this register is reserved.

6.1.34 Bank 2 RF (Pull-high Control Register 1)

Bit 7	Bit 6	Bit 5	Bit 4	Bit 3	Bit 2	Bit 1	Bit 0
/PH77	/PH76	/PH75	/PH74	/PH73	/PH72	"1"	"1"

Bit 7 (/PH77): Control bit used to enable pull-high on the P77 pin

0: Enable internal pull-high

1: Disable internal pull-high

Bit 6 (/PH76): Control bit used to enable pull-high on the P76 pin.

Bit 5 (/PH75): Control bit used to enable pull-high on the P75 pin.

Bit 4 (/PH74): Control bit used to enable pull-high on the P74 pin.

Bit 3 (/PH73): Control bit used to enable pull-high on the P73 pin.

Bit 2 (/PH72): Control bit used to enable pull-high on the P72 pin.

Bits 1 ~ 0: Not used, set to "1" all the time.

NOTE

- The RF Register is both readable and writable.
- For F642/542N, Bit 6 ~ Bit 5, Bit 3 ~ Bit 0 are unused. Set to "1" all the time.
- For F641/541N, Bit 7 ~ Bit 0 are unused. Set to "1" all the time.

6.1.35 Bank 3 R5 (TMRCON: Timer A and Timer B Control Register)

Bit 7	Bit 6	Bit 5	Bit 4	Bit 3	Bit 2	Bit 1	Bit 0
TAEN	TAP2	TAP1	TAP0	TBEN	TBP2	TBP1	TBP0

NOTE
For F642/542N, F641/541N, this register is reserved.

Bit 7 (TAEN): Timer A enable bit

0: Disable Timer A (default)

1: Enable Timer A

Bits 6 ~ 4 (TAP2 ~ TAP0): Timer A clock prescaler option bits.

Bit 3 (TBEN): Timer B enable bit

0: Disable Timer A (default)

1: Enable Timer A

Bits 2 ~ 0 (TBP2 ~ TBP0): Timer B clock prescaler option bits

TAP2/TBP2	TAP1/TBP1	TAP0/TBP0	Prescale
0	0	0	1:2 (Default)
0	0	1	1:4
0	1	0	1:8
0	1	1	1:16
1	0	0	1:32
1	0	1	1:64
1	1	0	1:128
1	1	1	1:256

6.1.36 Bank 3 R6 (TBHP: Table Pointer Register for Instruction TBRD)

Bit 7	Bit 6	Bit 5	Bit 4	Bit 3	Bit 2	Bit 1	Bit 0
MLB	-	-	-	RBit11	RBit10	RBit9	RBit8

Bit 7 (MLB): Select MSB or LSB machine code to be moved to the register.

The machine code is pointed by the TBLP and TBHP registers.

Bits 6 ~ 4: Not used, set to "0" all the time.

Bits 3 ~ 0: These are the 4 most significant bits of program code address

NOTE

- For F642/542N, Bit 3 is unused. Set to "0" all the time.
- For F641/541N, Bit 3 and Bit 2 are unused. Set to "0" all the time.

6.1.37 Bank 3 R7 (CMPCON: Comparator 2 Control Register and PWMA/B Control Register)

Bit 7	Bit 6	Bit 5	Bit 4	Bit 3	Bit 2	Bit 1	Bit 0
-	-	-	CPOUT2	COS21	COS20	PWMAE	PWMBE

Bit 7 ~ Bit 5: Not used, set to "0" all the time

Bit 4 (CPOUT2): The result of Comparator 2 output

Bit 3 ~ Bit 2 (COS21 ~ COS20): Comparator 2 select bits

COS21	COS20	Function Description
0	0	Comparator 2 is not used. P80 acts as normal I/O pin
0	1	Act as a Comparator 2 and P80 acts as normal I/O pin
1	0	Act as a Comparator 2 and P80 acts as Comparator 2 output pin (CO)
1	1	Not used

Bit 1 (PWMAE): PWMA enable bit.

0: PWMA is off and its related pin carries out the P75 function (default).

1: PWMA is on, and its related pin is automatically set to output.

Bit 0 (PWMBE): PWMB enable bit.

0: PWMB is off and its related pin carries out the P76 function (default).

1: PWMB is on, and its related pin is automatically set to output.

NOTE

- For F642/542N, Bit 1 and Bit 0 are unused. Set to "0" all the time.
- For F641/541N, Bit 1 and Bit 0 are unused. Set to "0" all the time.

6.1.38 Bank 3 R8 (PWMCON: PWMA/B Lower 2 Bits of the Period and Duty Control Register)

Bit 7	Bit 6	Bit 5	Bit 4	Bit 3	Bit 2	Bit 1	Bit 0
PRDA [1]	PRDA [0]	DTA [1]	DTA [0]	PRDB [1]	PRDB [0]	DTB [1]	DTB [0]

NOTE

For F642/542N, F641/541N, this register is reserved.

Bits 7 ~ 6 (PRDA [1], PRDA [0]): Least Significant Bits of PWMA Period Cycle.

Bits 5 ~ 4 (DTA [1], DTA [0]): Least Significant Bits of PWMA Duty Cycle.

Bits 3 ~ 2 (PRDB [1], PRDB [0]): Least Significant Bits of PWMB Period Cycle.

Bits 1 ~ 0 (DTB [1], DTB [0]): Least Significant Bits of PWMB Duty Cycle.

6.1.39 Bank 3 R9 (PRDAH: Most Significant Byte (Bit 9 ~ Bit 2) of PWMA)

Bit 7	Bit 6	Bit 5	Bit 4	Bit 3	Bit 2	Bit 1	Bit 0
PRDA[9]	PRDA[8]	PRDA[7]	PRDA[6]	PRDA[5]	PRDA[4]	PRDA[3]	PRDA[2]

The content of Bank 3 of R9 is a period (time base) of PWMA Bit 9 ~ Bit 2. The frequency of PWMA is the reverse of the period.

NOTE

For F642/542N, F641/541N, this register is reserved.

6.1.40 Bank 3 RA (DTAH: Most Significant Byte (Bit 9 ~ Bit 2) of PWMA Duty Cycle)

Bit 7	Bit 6	Bit 5	Bit 4	Bit 3	Bit 2	Bit 1	Bit 0
DTA[9]	DTA[8]	DTA[7]	DTA[6]	DTA[5]	DTA[4]	DTA[3]	DTA[2]

A specified value keeps the PWMA output to remain high until the value matches with TMRA.

NOTE

For F642/542N, F641/541N, this register is reserved.

6.1.41 Bank 3 RB (PRDBH: Most Significant Byte (Bit 9~Bit 2) of PWMB)

Bit 7	Bit 6	Bit 5	Bit 4	Bit 3	Bit 2	Bit 1	Bit 0
PRDB[9]	PRDB[8]	PRDB[7]	PRDB[6]	PRDB[5]	PRDB[4]	PRDB[3]	PRDB[2]

The content of Bank 3 of R9 is a period (time base) of PWMB Bit 9~Bit 2. The frequency of PWMB is the reverse of the period.

NOTE

For F642/542N, F641/541N, this register is reserved.

6.1.42 Bank 3 RC (DTBH: Least Significant Byte (Bit 9 ~ Bit 2) of PWMB Duty Cycle)

Bit 7	Bit 6	Bit 5	Bit 4	Bit 3	Bit 2	Bit 1	Bit 0
DTB[9]	DTB[8]	DTB[7]	DTB[6]	DTB[5]	DTB[4]	DTB[3]	DTB[2]

A specified value keeps the PWMB output to remain high until the value matches with TMRB.

NOTE

For F642/542N, F641/541N, this register is reserved.

6.1.43 Bank 3 RD TC3CR (Timer 3 Control)

Bit 7	Bit 6	Bit 5	Bit 4	Bit 3	Bit 2	Bit 1	Bit 0
TC3FF1	TC3FF0	TC3S	TC3CK2	TC3CK1	TC3CK0	TC3M1	TC3M0

Bits 7 ~ 6 (TC3FF1 ~ TC3FF0): Timer/Counter 3 flip-flop control

TC3FF1	TC3FF0	Operating Mode
0	0	Clear
0	1	Toggle
1	0	Set
1	1	Reserved

Bit 5 (TC3S): Timer/Counter 3 start control

0: Stop and clear the counter

1: Start Timer/Counter 3

Bits 4 ~ 2 (TC3CK2 ~ TC3CK0): Timer/Counter 3 clock source select

TC3CK2	TC3CK1	TC3CK0	Clock Source	Resolution	Max. Time	Resolution	Max. Time
			Normal, Idle	Fc=4M	Fc=4M	Fc=16K	Fc=16K
0	0	0	$Fc/2^{11}$	512 μ s	131072 μ s	128 ms	32768 ms
0	0	1	$Fc/2^7$	32 μ s	8192 μ s	8 ms	2048 ms
0	1	0	$Fc/2^5$	8 μ s	2048 μ s	2 ms	512 ms
0	1	1	$Fc/2^3$	2 μ s	512 μ s	500 μ s	128 ms
1	0	0	$Fc/2^2$	1 μ s	256 μ s	250 μ s	64 ms
1	0	1	$Fc/2^1$	500 ns	128 μ s	125 μ s	32 ms
1	1	0	Fc	250 ns	64 μ s	62.5 μ s	16 ms
1	1	1	External clock (TC3 pin)	-	-	-	-

Bits 1 ~ 0 (TC3M1 ~ TC3M0): Timer/Counter 3 operating mode select

TC3M1	TC3M0	Operating Mode
0	0	Timer/Counter
0	1	Reserved
1	0	Programmable Divider Output
1	1	Pulse Width Modulation Output

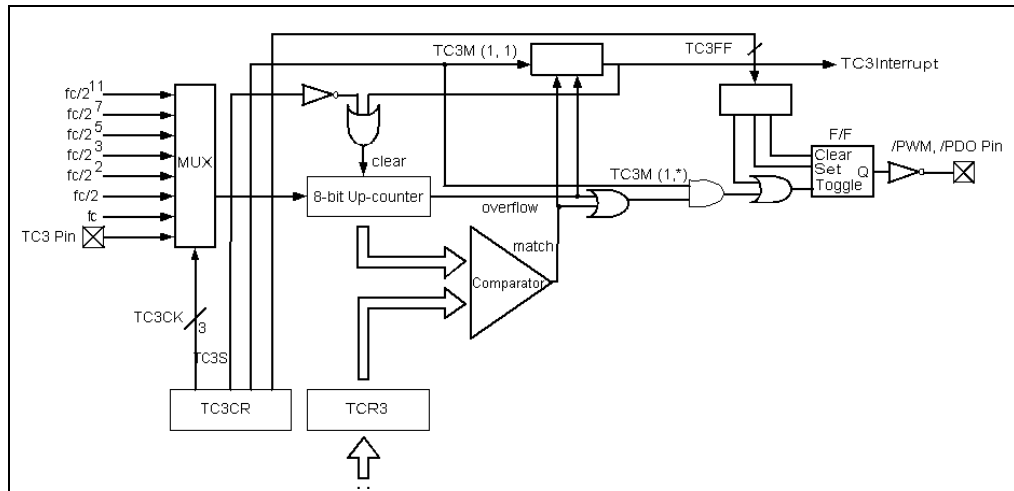

Figure 6-5a Timer / Counter 3 Configuration

In Timer mode, counting up is performed using the internal clock (rising edge trigger). When the contents of the up-counter match the TCR3, then interrupt is generated and the counter is cleared. Counting up resumes after the counter is cleared.

In Counter mode, counting up is performed using an external clock input pin (TC3 pin). When the contents of the up-counter match the TCR3, then interrupt is generated and the counter is cleared. Counting up resumes after the counter is cleared.

In Programmable Divider Output (PDO) mode, counting up is performed using the internal clock. The contents of TCR3 are compared with the contents of the up-counter. The F/F output is toggled and the counter is cleared each time a match is found. The F/F output is inverted and output to /PDO pin. This mode can generate 50% duty pulse output. **The F/F can be initialized by the program and it is initialized to “0” during reset.** A TC3 interrupt is generated each time the /PDO output is toggled.

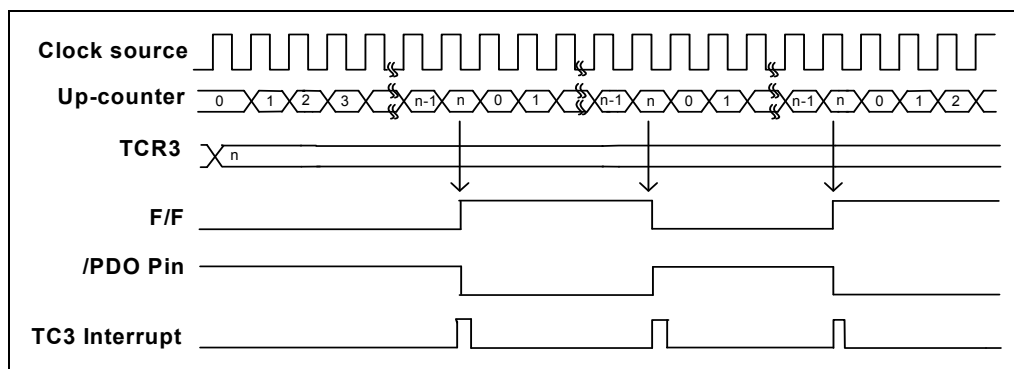

Figure 6-5b PDO Mode Timing Chart

In Pulse Width Modulation (PWM) Output Mode, counting up is performed using the internal clock. The contents of TCR3 are compared with the contents of the up-counter. The F/F is toggled when a match is found. While the counter continues counting, the F/F is toggled again when the counter overflows, after which the counter is cleared. The F/F output is inverted and output to /PWM pin. A TC3 interrupt is generated each time an overflow occurs. **TCR3 is configured as a 2-stage shift register and, during output, will not switch until one output cycle is completed even if TCR3 is overwritten.** Therefore, the output can be changed continuously. However, only when TC3S is set to “1” will the TCR3 start to shift and allows data to be loaded into TCR3.

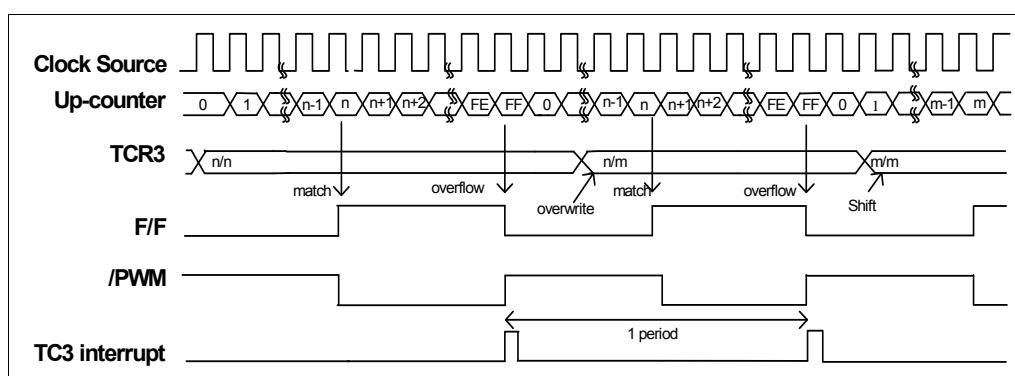

Figure 6-5c PWM Mode Timing Chart

6.1.44 Bank 3 RE TC3D (Timer 3 Data Buffer)

Bit 7	Bit 6	Bit 5	Bit 4	Bit 3	Bit 2	Bit 1	Bit 0
TC3D7	TC3D6	TC3D5	TC3D4	TC3D3	TC3D2	TC3D1	TC3D0

Bits 7 ~ 0 (TC3D7 ~ TC3D0): Data Buffer of 8-bit Timer/Counter 3.

6.1.45 Bank 3 RF (Pull-Down Control Register 1)

Bit 7	Bit 6	Bit 5	Bit 4	Bit 3	Bit 2	Bit 1	Bit 0
/PD77	/PD76	/PD75	/PD74	/PD73	/PD72	"1"	"1"

Bit 7 (/PD77): Control bit used to enable pull-down on P77 pin

- 0: Enable internal pull-down
- 1: Disable internal pull-down

Bit 6 (/PD76): Control bit used to enable pull-down of the P76 pin.

Bit 5 (/PD75): Control bit used to enable pull-down of the P75 pin.

Bit 4 (/PD74): Control bit used to enable pull-down of the P74 pin.

Bit 3 (/PD73): Control bit used to enable pull-down of the P73 pin.

Bit 2 (/PD72): Control bit used to enable pull-down of the P72 pin.

Bits 1 ~ 0: Not used, set to “1” all the time.

NOTE

- The RF register is both readable and writable.
- For F642/542N, Bit 6 ~ Bit 5, Bit 3 ~ Bit 0 are unused. Set to “1” all the time.
- For F641/541N, Bit 7 ~ Bit 0 are unused. Set to “1” all the time.

6.2 Special Function Registers (for EM78F644/642/641/544/542/541N Series only)

6.2.1 A (Accumulator)

Internal data transfer operation or instruction operand holding usually involves the temporary storage function of the Accumulator. The Accumulator is not an addressable register.

6.2.2 CONT (Control Register)

Bit 7	Bit 6	Bit 5	Bit 4	Bit 3	Bit 2	Bit 1	Bit 0
INTE	/INT	TS	TE	PSTE	PST2	PST1	PST0

Bit 7 (INTE): INT signal edge

- 0: Interrupt occurs at a rising edge of the INT pin
- 1: Interrupt occurs at a falling edge of the INT pin

Bit 6 (/INT): Interrupt Enable Flag

- 0: Masked by DISI or hardware interrupt
- 1: Enabled by ENI/RETI instructions

Bit 5 (TS): TCC signal source

- 0: Internal oscillator cycle clock. If P77 is used as I/O pin, TS must be 0
- 1: Transition on the TCC pin

Bit 4 (TE): TCC signal edge

- 0: Increment if a transition from low to high takes place on the TCC pin
- 1: Increment if a transition from high to low takes place on the TCC pin

NOTE

For F641/541N, Bit 5 ~ Bit 4 are unused. Set to “0” all the time.

Bit 3 (PSTE): Prescaler enable bit for TCC

- 0: Prescaler disable bit, the TCC rate is 1:1
- 1: Prescaler enable bit, the TCC rate is set as Bit 2 ~ Bit 0

Bit 2 ~ Bit 0 (PST 2 ~ PST0): TCC prescaler bits

PST2	PST1	PST0	TCC Rate
0	0	0	1:2
0	0	1	1:4
0	1	0	1:8
0	1	1	1:16
1	0	0	1:32
1	0	1	1:64
1	1	0	1:128
1	1	1	1:256

NOTE

The CONT register is both readable and writable.

6.2.3 IOC5 (I/O Port 5 Control Register)

Bit 7	Bit 6	Bit 5	Bit 4	Bit 3	Bit 2	Bit 1	Bit 0
C57	C56	C55	C54	C53	C52	C51	C50

Bits 7 ~ 0 (C57 ~ C50): 8-bit Port 5 I/O data register

0: Define the I/O pin as output

1: Define the I/O pin as high impedance

User can use the IOC5 register to define each bit as input or output.

NOTE

- For F642/542N, Bit 6, Bit 3 ~ Bit 1 are unused. Set to "0" all the time.
- For F641/541N, Bit 6, Bit 3 ~ Bit 1 are unused. Set to "0" all the time.

6.2.4 IOC6 (I/O Port 6 Control Register)

Bit 7	Bit 6	Bit 5	Bit 4	Bit 3	Bit 2	Bit 1	Bit 0
C67	C66	C65	C64	C63	C62	C61	C60

Bits 7 ~ 0 (C67 ~ C60): 8-bit Port 6 I/O data register

0: Define the I/O pin as output

1: Define the I/O pin as high impedance

User can use the IOC6 register to define each bit as input or output.

NOTE

For F641/541N, Bit 7 ~ Bit 6 are unused. Set to "0" all the time.



6.2.5 IOC7 (I/O Port 7 Control Register)

Bit 7	Bit 6	Bit 5	Bit 4	Bit 3	Bit 2	Bit 1	Bit 0
C77	C76	C75	C74	C73	C72	-	-

Bits 7 ~ 2 (C77 ~ C72): 6-bit Port 7 I/O data register

0: Define I/O pin as output

1: Define I/O pin as high impedance

Bits 1 ~ 0: Not used, set to "0" all the time.

User can use the IOC7 register to define each bit as input or output.

NOTE

- For F642/542N, Bit 6 ~ Bit 5, Bit 3 ~ Bit 0 are unused. Set to "0" all the time.
- For F641/541N, Bit 7 ~ Bit 0 are unused. Set to "0" all the time.

6.2.6 IOC8 (I/O Port 8 Control Register)

Bit 7	Bit 6	Bit 5	Bit 4	Bit 3	Bit 2	Bit 1	Bit 0
-	-	-	-	C83	C82	C81	C80

Bits 7 ~ 4: Not used, set to "0" all the time.

Bits 3 ~ 0 (C83 ~ C80): 4-bit Port 8 I/O data register

0: Define I/O pin as output

1: Define I/O pin as high impedance

User can use the IOC8 register to define each bit as input or output.

NOTE

For F644N/544n, Bit 3 is unused. Set to "0" all the time.

6.2.7 IOC9

Reserved registers

6.2.8 IOCA (WDT Control Register)

Bit 7	Bit 6	Bit 5	Bit 4	Bit 3	Bit 2	Bit 1	Bit 0
WDTE	EIS	-	-	PSWE	PSW2	PSW1	PSW0

Bit 7 (WDTE): Control bit used to enable the Watchdog timer

0: Disable WDT

1: Enable WDT

WDTE is both readable and writable.

Bit 6 (EIS): Control bit used to define the P60 (/INT) pin function

0: P60, bidirectional I/O pin

1: /INT, external interrupt pin. In this case, the I/O control bit of P60 (Bit 0 of IOC6) must be set to "1".

When EIS is "0", the /INT path is masked. When EIS is "1", the status of the /INT pin can also be read by way of reading Port 6 (R6).

The EIS is both readable and writable.

Bits 5 ~ 4: Not used, set to "0" all the time

Bit 3 (PSWE): Prescaler enable bit for WDT

0: Prescaler disable bit. WDT rate is 1:1

1: Prescaler enable bit. WDT rate is set at Bit 0~Bit 2

Bit 2 ~ Bit 0 (PSW2 ~ PSW0): WDT prescaler bits

PSW2	PSW1	PSW0	WDT Rate
0	0	0	1:2
0	0	1	1:4
0	1	0	1:8
0	1	1	1:16
1	0	0	1:32
1	0	1	1:64
1	1	0	1:128
1	1	1	1:256

6.2.9 IOCB (Pull-Down Control Register 2)

Bit 7	Bit 6	Bit 5	Bit 4	Bit 3	Bit 2	Bit 1	Bit 0
/PD63	/PD62	/PD61	/PD60	/PD53	/PD52	/PD51	/PD50

Bit 7 (/PD63): Control bit used to enable pull-down of the P63 pin.

0: Enable internal pull-down

1: Disable internal pull-down

Bit 6 (/PD62): Control bit used to enable pull-down on P62 pin

Bit 5 (/PD61): Control bit used to enable pull-down on P61 pin

Bit 4 (/PD60): Control bit used to enable pull-down on P60 pin

Bit 3 (/PD53): Control bit used to enable pull-down on P53 pin

Bit 2 (/PD52): Control bit used to enable pull-down on P52 pin

Bit 1 (/PD51): Control bit used to enable pull-down on P51 pin

Bit 0 (/PD50): Control bit used to enable pull-down on P50 pin



The IOCB Register is both readable and writable.

NOTE

- For F642/542N, Bit 3 ~ Bit 1 are unused. Set to "1" all the time.
- For F641/541N, Bit 3 ~ Bit 1 are unused. Set to "1" all the time.

6.2.10 IOCC (Open-Drain Control Register)

Bit 7	Bit 6	Bit 5	Bit 4	Bit 3	Bit 2	Bit 1	Bit 0
OD67	OD66	OD65	OD64	OD63	OD62	OD61	OD60

Bit 7 (OD67): Control bit used to enable open-drain output of the P67 pin.

0: Disable open-drain output

1: Enable open-drain output

Bit 6 (OD66): Control bit used to enable open-drain output on P66 pin

Bit 5 (OD65): Control bit used to enable open-drain output on P65 pin

Bit 4 (OD64): Control bit used to enable open-drain output on P64 pin

Bit 3 (OD63): Control bit used to enable open-drain output on P63 pin

Bit 2 (OD62): Control bit used to enable open-drain output on P62 pin

Bit 1 (OD61): Control bit used to enable open-drain output on P61 pin

Bit 0 (OD60): Control bit used to enable open-drain output on P60 pin

The IOCC Register is both readable and writable.

NOTE

For F641/541N, Bit 7 ~ Bit 6 are unused. Set to "0" all the time.

6.2.11 IOCD (Pull-High Control Register 2)

Bit 7	Bit 6	Bit 5	Bit 4	Bit 3	Bit 2	Bit 1	Bit 0
/PH67	/PH66	/PH65	/PH64	/PH63	/PH62	/PH61	/PH60

Bit 7 (/PH67): Control bit used to enable pull-high of the P67 pin.

0: Enable internal pull-high

1: Disable internal pull-high

Bit 6 (/PH66): Control bit used to enable pull-high on P66 pin

Bit 5 (/PH65): Control bit used to enable pull-high on P65 pin

Bit 4 (/PH64): Control bit used to enable pull-high on P64 pin

Bit 3 (/PH63): Control bit used to enable pull-high on P63 pin

Bit 2 (/PH62): Control bit used to enable pull-high on P62 pin

Bit 1 (/PH61): Control bit used to enable pull-high on P61 pin

Bit 0 (/PH60): Control bit used to enable pull-high on P60 pin

The IOCD Register is both readable and writable.

NOTE

For F641/541N, Bit 7 ~ Bit 6 are unused. Set to "1" all the time.

6.2.12 IOCE (Interrupt Mask Register 2)

Bit 7	Bit 6	Bit 5	Bit 4	Bit 3	Bit 2	Bit 1	Bit 0
CMP2IE	-	TC3IE	TC2IE	TC1IE	UERRIE	URIE	UTIE

Bit 7 (CMP2IE): CMP2IF interrupt enable bit.

0: Disable CMP2IF interrupt

1: Enable CMP2IF interrupt

When the Comparator 2 output status change is used to enter an interrupt vector or enter the next instruction, the CMP2IE bit must be set to "Enable".

Bit 6: Not used, set to "0" all the time.

Bit 5 (TC3IE): Interrupt enable bit

0: Disable TC3IF interrupt

1: Enable TC3IF interrupt

Bit 4 (TC2IE): Interrupt enable bit

0: Disable TC2IF interrupt

1: Enable TC2IF interrupt

Bit 3 (TC1IE): Interrupt enable bit

0: Disable TC1IF interrupt

1: Enable TC1IF interrupt

Bit 2 (UERRIE): UART receive error interrupt enable bit

0: Disable UERRIF interrupt

1: Enable UERRIF interrupt

Bit 1 (URIE): UART receive mode Interrupt enable bit

0: Disable RBFF interrupt

1: Enable RBFF interrupt

Bit 0 (UTIE): UART transmit mode interrupt enable bit.

0: Disable TBEF interrupt

1: Enable TBEF interrupt

The IOCE Register is both readable and writable.

NOTE	
■	<i>For F642/542N, Bit 2 ~ Bit 0 are unused. Set to "0" all the time.</i>
■	<i>For F641/541N, Bit 4 ~ Bit 0 are unused. Set to "0" all the time.</i>

6.2.13 IOCF (Interrupt Mask Register 1)

Bit 7	Bit 6	Bit 5	Bit 4	Bit 3	Bit 2	Bit 1	Bit 0
-	-	SPIIE	PWMBIE	PWMAIE	EXIE	ICIE	TCIE

Bits 7 ~ 6: Not used, set to "0" all the time.

Bit 5 (SPIIE): SPIIF interrupt enable bit.

- 0: Disable SPIIF interrupt
- 1: Enable SPIIF interrupt

Bit 4 (PWMBIE): PWMBIF interrupt enable bit

- 0: Disable PWMBIF interrupt
- 1: Enable PWMBIF interrupt

Bit 3 (PWMAIE): PWMAIF interrupt enable bit

- 0: Disable PWMAIF interrupt
- 1: Enable PWMAIF interrupt

Bit 2 (EXIE): EXIF interrupt enable bit

- 0: Disable EXIF interrupt
- 1: Enable EXIF interrupt

Bit 1 (ICIE): ICIF interrupt enable bit

- 0: Disable ICIF interrupt
- 1: Enable ICIF interrupt

Bit 0 (TCIE): TCIF interrupt enable bit

- 0: Disable TCIF interrupt
- 1: Enable TCIF interrupt

The IOCF Register is both readable and writable.

NOTE	
■	<i>Individual interrupt is enabled by setting its associated control bit in the IOCF to "1".</i>
■	<i>Global interrupt is enabled by the ENI instruction and disabled by the DISI instruction.</i>
■	<i>For F642/542N, Bit 5 ~ Bit 3 are unused. Set to "0" all the time.</i>
■	<i>For F641/541N, Bit 5 ~ Bit 3 are unused. Set to "0" all the time.</i>

6.3 Operational Registers for EM78F648/548N

6.3.1 R0: IAR (Indirect Addressing Register)

R0 is not a physically implemented register. Its major function is to perform as an indirect addressing pointer. Any instruction using R0 as a pointer actually accesses data pointed by the RAM Select Register (R4).

6.3.2 R1: BSR (Bank Selection Control Register)

Bit 7	Bit 6	Bit 5	Bit 4	Bit 3	Bit 2	Bit 1	Bit 0
0	0	0	SBS0	0	0	0	GBS0

Bits 7 ~ 5: Not used, set to "0" all the time.

Bit 4 (SBS0): Special register bank select bit. It is used to select Bank 0/1 of special register R5~R4F.

0: Bank 0

1: Bank 1

Bits 3~1: Not used, set to "0" all the time.

Bit 0 (GBS0): General register bank select bit. It is used to select Bank 0/1 of general register R80~RFF.

0: Bank 0

1: Bank 1

6.3.3 R2: PC (Program Counter)

- Depending on the device type, R2 and hardware stack are 12-bit wide. The program counter structure is depicted in Figure 6-6.
- Generates 8K×15 bits on-chip Flash ROM addresses to the relative programming instruction codes. One program page is 4096 words long.
- R2 is set as all "0"s when under RESET condition.
- "JMP" instruction allows direct loading of the lower 12 program counter bits. Thus, "JMP" allows the PC to go to any location within a page.
- "CALL" instruction loads the lower 12 bits of the PC, and the present PC value will add 1 and is pushed into the stack. Thus, the subroutine entry address can be located anywhere within a page.
- "LJMP" instruction allows direct loading of the lower 13 program counter bits. Therefore, "LJMP" allows the PC to jump to any location within 8K (2^{13}).
- "LCALL" instruction loads the lower 13 bits of the PC, and PC+1 are pushed into the stack. Thus, the subroutine entry address can be located anywhere within 8K (2^{13}).
- "RET" ("RETL k", "RETI") instruction loads the program counter with the contents of the top-level stack.

- "ADD R2, A" allows a relative address to be added to the current PC, and the ninth and above bits of the PC will be incremented progressively.
- "MOV R2, A" allows to load an address from the "A" register to the lower 8 bits of the PC, and the ninth and above bits of the PC are not changed.
- •Any instruction (except "ADD R2,A") that is written to R2 (e.g., "MOV R2, A", "BC R2, 6", etc.) will cause the ninth bit and the above bits (A8~A11) of the PC to remain unchanged.
- All instructions are single instruction cycle (fclk/2, fclk/4, fclk/8, fclk/16). The instruction that would change the contents of R2 will need one more instruction cycle.

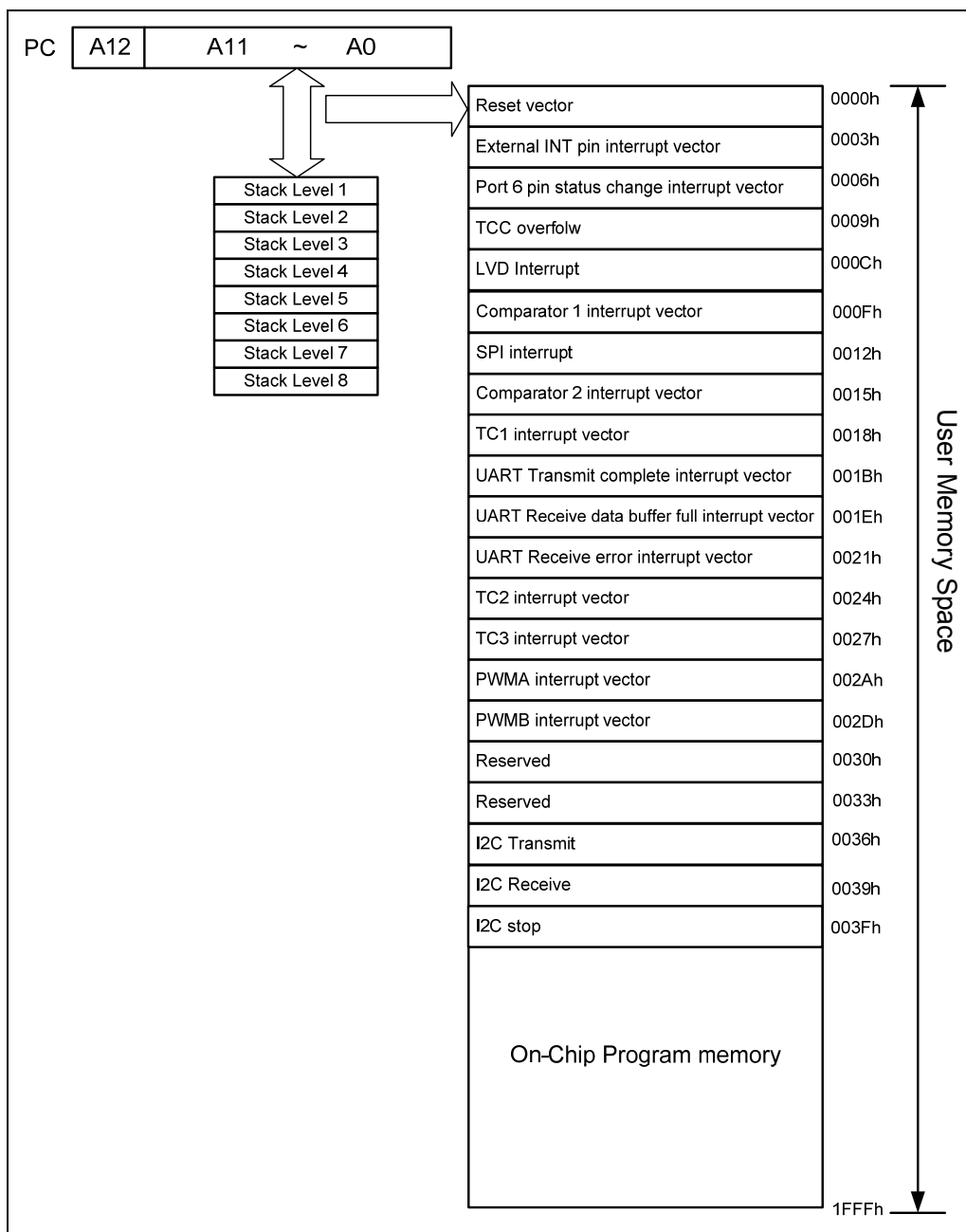

Figure 6-6 Program Counter Structure

■ Data Memory Configuration

Address	Bank 0	Bank 1
0X00	IAR (Indirect Addressing Register)	
0X01	BSR (Bank Selection Control Register)	
0X02	PC (Program Counter)	
0X03	SR (Status Register)	
0X04	RSR (RAM Select Register)	
0X05	Port 5	P5PHCR
0X06	Port 6	P6PHCR
0X07	Port 7	P7PHCR
0X08	Port 8	P8PHCR
0X09	Port 9	P9PHCR
0X0A	-	-
0x0B	OMCR (Operating Mode Control Register)	P5PLCR
0X0C	ISR1 (Interrupt Status Register 1)	P6PLCR
0X0D	ISR2 (Interrupt Status Register 2)	P7PLCR
0X0E	ISR3 (Interrupt Status Register 3)	P8PLCR
0X0F	-	P9PLCR
0X10	EIESCR	-
0X11	WDTCR	P5HD/SCR
0X12	LVDCCR	P6HD/SCR
0X13	TCCCR	P7HD/SCR
0X14	TCCDATA	P8HD/SCR
0X15	IOCR5	P9HD/SCR
0X16	IOCR6	-
0X17	IOCR7	P5ODCR
0X18	IOCR8	P6ODCR
0X19	IOCR9	P7ODCR
0X1A	-	P8ODCR
0X1B	-	P9ODCR
0X1C	IMR1 (Interrupt Mask Register 1)	-
0X1D	IMR2 (Interrupt Mask Register 2)	IRCS
0X1E	IMR3 (Interrupt Mask Register 3)	-
0X1F	-	EEROM CONTROL
0X20	P5WUCR	EEPROM ADDR
0X21	P5WUECR	EEPROM DATA

(Continuation)

Address	Bank 0	Bank 1
0X22	P7WUCR	-
0X23	P7WUECR	I2CCR1 (I2C Status and Control Register 1)
0X24	-	I2CCR2 (I2C Status and Control Register 2)
0X25	-	I2CSA (I2C Slave Address Register)
0X26	-	I2CDA (I2C Device Address Register)
0X27	-	I2CDB (I2C Data Buffer)
0X28	-	I2CA
0X29	-	-
0X2A	-	PWMER (PWM Enable Control Register)
0x2B	SPICR (SPI Control Register)	TIMEN (Timer/PWM Enable Control Register)
0X2C	SPIS (SPI Status Register)	-
0X2D	SPIR (SPI Read Buffer)	-
0X2E	SPIW (SPI Write Buffer)	-
0X2F	WUCR1	PWMACR (PWM A Control Register)
0X30	-	PWMBCR (PWM B Control Register)
0X31	-	-
0X32	URCR1 (UART Control Register 1)	TACR (Timer A Control Register)
0X33	URCR2 (UART Control Register 2)	TBCR (Timer B Control Register)
0X34	URS (UART Status Register)	-
0X35	URRD (UART Receive Data Buffer Register)	TAPRD (Timer A Period Buffer)
0X36	URTD (UART Transmit Data Buffer Register)	TBPRD (Timer B Period Buffer)
0X37	TBPTL	-
0X38	TBPTH	TADT (Timer A Duty Buffer)
0X39	CMP1CR (Comparator 1 Control Register)	TBDT (Timer B Duty Buffer)
0X3A	-	-
0x3B	-	PRDxL
0X3C	CMP2CR	DTxL
0X3D	-	-
0X3E	-	-
0X3F	-	-
0X40	-	-
0X41	-	-
0X42	-	-
0X43	CPIRLCON	-
0X44	-	-

(Continuation)

Address	Bank 0	Bank 1
0X45	-	-
0X46	-	-
0X47	-	-
0X48	TC1CR	-
0X49	TCR1DA	-
0X4A	TCR1DB	-
0x4B	TC2CR	-
0X4C	TCR2DH	-
0X4D	TCR2DL	-
0X4E	TC3CR	-
0X4F	TCR3D	-
0X50	General Purpose Register	
0X51		
.		
.		
0X7F		
0X80	Bank 0	Bank 1
0X81		
.		
.		
.		
0XFE		
0XFF		

6.3.4 R3: SR (Status Register)

Bit 7	Bit 6	Bit 5	Bit 4	Bit 3	Bit 2	Bit 1	Bit 0
0	0	0	T	P	Z	DC	C

Bits 7~5: Not used, set to "0" all the time.

Bit 4 (T): Time-out bit

Set to "1" by "SLEP" and "WDTC" command executions or during power up. Reset to "0" when WDT time-out occurs.

Bit 3 (P): Power down bit

Set to "1" at power on or by "WDTC" command execution. Reset to "0" by "SLEP" command execution.

Bit 2 (Z): Zero flag

Set to "1" if the result of an arithmetic or logic operation is zero.

Bit 1 (DC): Auxiliary carry flag

Bit 0 (C): Carry flag

6.3.5 R4: RSR (RAM Select Register)

Bit 7	Bit 6	Bit 5	Bit 4	Bit 3	Bit 2	Bit 1	Bit 0
RSR7	RSR6	RSR5	RSR4	RSR3	RSR2	RSR1	RSR0

Bits 7~0 (RSR7~RSR0): These bits are used to select registers (Address: 00~FF) in indirect address mode. Refer to the table on Data Memory Configuration (Section 6.3.3) for more details.

6.3.6 Bank 0 R5 ~ R9 (Port 5 ~ Port 9)

R5, R6, R7, R8, and R9 are I/O data registers.

6.3.7 Bank 0 RA (Not Used)

6.3.8 Bank 0 RB OMCR (Operating Mode Control Register)

Bit 7	Bit 6	Bit 5	Bit 4	Bit 3	Bit 2	Bit 1	Bit 0
CPUS	IDLE	TC1SS	TC2SS	TC3SS	TASS	TBSS	0

Bit 7 (CPUS): CPU Oscillator Source Select.

0: Fs: sub-oscillator for WDT internal RC time base

1: Fm: main-oscillator

When CPUS=0, the CPU oscillator will select the sub-oscillator, and the main oscillator is stopped.

Bit 6 (IDLE): Idle mode enable bit. This bit defines and instructs SLEP instruction which mode to go after the instruction is executed.

0: "IDLE=0"+SLEP instruction → Sleep mode

1: "IDLE=1"+SLEP instruction → Idle mode

■ CPU Operation Mode

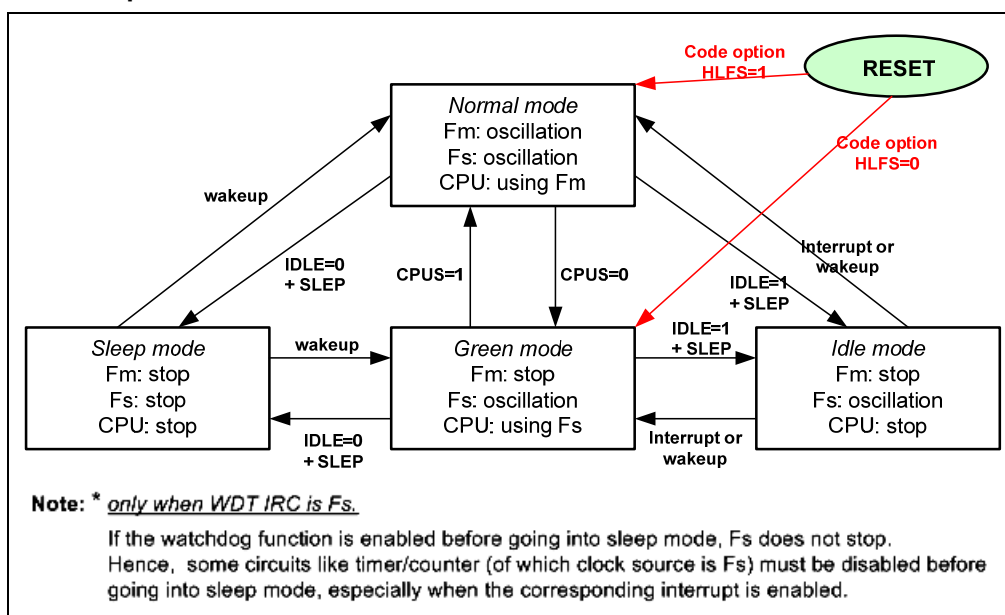

Figure 6-7 CPU Operation Mode Block Diagram

Oscillator (Normal Mode Source)	CPU Mode Status	Oscillator Stable Time (S) ¹	Count from Normal/Green (CLK) ²
Crystal ; 1M ~ 16 MHz	Sleep/Idle → Normal	0.5 ms ~ 2 ms	254 CLK
	Green → Normal		254 CLK
	Sleep/Idle → Green	< 100 μs	32 CLK
ERC ; 3.5 MHz	Sleep/Idle → Normal	< 5 μs	32 CLK
	Green → Normal		
	Sleep/Idle → Green	< 100 μs	
IRC ; 455K, 4M, 8M, 16 MHz	Sleep/Idle → Normal	< 2 μs	32 CLK
	Green → Normal		
	Sleep/Idle → Green	< 100 μs	

¹ The oscillator stable time depends on the oscillator characteristics

² After the oscillator has stabilized, the CPU will count 254/32 CLK in Normal/Green mode and continue to work in Normal/Green mode.

Ex 1: The 4 MHz IRC wakes-up from Sleep mode to Normal mode. The total wake-up time is 2 μs + 32 CLK @ 4 MHz

Ex 2: The 4 MHz IRC wakes-up from Sleep mode to Green mode. The total wake-up time is 100 μs + 32 CLK @ 16kHz

Bit 5 (TC1SS): TC1 clock source select bit

0: Fs is used as Fc

1: Fm is used as Fc



- Bit 4 (TC2SS):** TC2 clock source select bit
0: Fs is used as Fc
1: Fm is used as Fc
- Bit 3 (TC3SS):** TC3 clock source select bit
0: Fs is used as Fc
1: Fm is used as Fc
- Bit 2 (TASS):** Timer A clock source select bit
0: Fs is used as Fc
1: Fm is used as Fc
- Bit 1 (TBSS):** Timer B clock source select bit
0: Fs is used as Fc
1: Fm is used as Fc
- Bit 0:** Not used, fixed to “0” all the time.

6.3.9 Bank 0 RC: ISR1 (Interrupt Status Register 1)

Bit 7	Bit 6	Bit 5	Bit 4	Bit 3	Bit 2	Bit 1	Bit 0
LVDIF	0	SPIF	PWMBIF	PWMAIF	EXIF	ICIF	TCIF

Note: Set to “1” to enable Interrupt Request “0” to disable interrupt execution

- Bit 7 (LVDIF):** Low voltage detector interrupt flag
 When LVD1, LVD0 = “0, 0”, Vdd > 2.3V, LVDIF is “0”,
 Vdd ≤ 2.3V, set LVDIF to “1”. LVDIF reset to “0” by software.
 When LVD1, LVD0 = “0, 1”, Vdd > 3.3V, LVDIF is “0”,
 Vdd ≤ 3.3V, set LVDIF to “1”. LVDIF reset to “0” by software.
 When LVD1, LVD0 = “1, 0”, Vdd > 4.0V, LVDIF is “0”,
 Vdd ≤ 4.0V, set LVDIF to “1”. LVDIF reset to “0” by software.
 When LVD1, LVD0 = “1, 1”, Vdd > 4.5V, LVDIF is “0”,
 Vdd ≤ 4.5V, set LVDIF to “1”. LVDIF reset to “0” by software.
- Bit 6:** Not used, fixed to “0” all the time.
- Bit 5 (SPIF):** SPI mode interrupt flag. Flag is cleared by software.
- Bit 4 (PWMBIF):** PWMB (Pulse Width Modulation) interrupt flag.
 Set when a selected period is reached. Reset by software.
- Bit 3 (PWMAIF):** PWMA (Pulse Width Modulation) interrupt flag.
 Set when a selected period is reached. Reset by software.
- Bit 2 (EXIF):** External interrupt flag.

Bit 1 (ICIF): Port 6 input status change interrupt flag.
Set when Port 6 input changes. Reset by software.

Bit 0 (TCIF): TCC overflow interrupt flag.
Set when TCC overflows. Reset by software.

6.3.10 Bank 0 RD: ISR2 (Interrupt Status Register 2)

Bit 7	Bit 6	Bit 5	Bit 4	Bit 3	Bit 2	Bit 1	Bit 0
CMP2IF	CMP1IF	TC3IF	TC2IF	TC1IF	UERRIF	RBF	TBEF

Bit 7 (CMP2IF): Comparator 2 Interrupt Flag. Set when a change occurs in the output of Comparator 2. Reset by software.

Bit 6 (CMP1IF): Comparator 1 Interrupt Flag. Set when a change occurs in the output of Comparator 1. Reset by software.

Bit 5 (TC3IF): 8-bit Timer/Counter 3 Interrupt Flag. Flag cleared by software.

Bit 4 (TC2IF): 16-bit Timer/Counter 2 Interrupt Flag. Flag cleared by software.

Bit 3 (TC1IF): 8-bit Timer/Counter 1 Interrupt Flag. Flag cleared by software.

Bit 2 (UERRIF): UART Receiving Error Interrupt. Flag cleared by software or UART disabled.

Bit 1 (RBF): UART receive mode data buffer full interrupt flag.
Flag cleared by software.

Bit 0 (TBEF): UART transmit mode data buffer empty interrupt flag.
Flag cleared by software.

6.3.11 Bank 0 RE: ISR3 (Interrupt Status Register 3)

Bit 7	Bit 6	Bit 5	Bit 4	Bit 3	Bit 2	Bit 1	Bit 0
0	0	0	0	I2CSTPIF	0	I2CRIF	I2CTIF

Bits 7~4: Not used, fixed to "0" all the time.

Bit 3 (I2CSTPIF): I2C slave receive data stop interrupt flag

Bit 2: Not used, fixed to "0" all the time.

Bit 1 (I2CRIF): I2C receive interrupt flag. Set when I2C receives 1byte data and responds ACK signal. Reset by firmware or I2C disable.

Bit 0 (I2CTIF): I2C transmit interrupt flag. Set when I2C transmits 1 byte data and receive handshake signal (ACK or NACK). Reset by firmware or I2C disable.

6.3.12 Bank 0 RF (Not Used)

6.3.13 Bank 0 R10: EIESCR (External Interrupt Edge Select Control Register)

Bit 7	Bit 6	Bit 5	Bit 4	Bit 3	Bit 2	Bit 1	Bit 0
0	0	0	0	0	0	0	EIES

Bits 7~1: Not used, fixed to "0" all the time.

Bit 0 (EIES): External interrupt edge select bit

0: Falling edge interrupt

1: Rising edge interrupt

6.3.14 Bank 0 R11: WDTCR

Bit 7	Bit 6	Bit 5	Bit 4	Bit 3	Bit 2	Bit 1	Bit 0
WDTE	EIS	INT	0	PSWE	PSW2	PSW1	PSW0

Bit 7 (WDTE): Watchdog Timer enable bit. WDTE is both readable and writable.

0: Disable WDT

1: Enable WDT

Bit 6 (EIS): P60/ /INT switch control bit. EIS is both readable and writable.

0: P60

1: /INT, external interrupt pin. In this case, the I/O control bit of P60 must be set to "1". When EIS is "0", the path of /INT is masked. When EIS is "1", the status of /INT pin can also be read through reading Port 6 (R6).

Bit 5 (INT): Interrupt Enable flag

0: Interrupt masked by DISI or hardware interrupt

1: Interrupt enabled by ENI/DISI instructions

Bit 4: Not used, fixed to "0" all the time

Bit 3 (PSWE): Prescaler enable bit for WDT

0: Prescaler disabled, WDT rate is 1:1

1: Prescaler enabled, WDT rate is set from Bits 2~0

Bits 2~0 (PSW2~PSW0): WDT Prescaler bits

PSW2	PSW1	PSW0	WDT Rate
0	0	0	1:2
0	0	1	1:4
0	1	0	1:8
0	1	1	1:16
1	0	0	1:32
1	0	1	1:64
1	1	0	1:128
1	1	1	1:256

6.3.15 Bank 0 R12: LVDCR (Low Voltage Detector Control Register)

Bit 7	Bit 6	Bit 5	Bit 4	Bit 3	Bit 2	Bit 1	Bit 0
0	0	0	0	LVDEN	/LVD	LVD1	LVD0

Bits 7~4: Not used, fixed to “0” all the time.

Bit 3 (LVDEN): Low voltage detector enable bit

0: LVD disable

1: LVD enable

Bit 2 (/LVD): Low voltage detector. This is a read only bit. When the VDD pin voltage is lower than LVD voltage interrupt level (which is set by LVD1 and LVD0), this bit will be cleared.

0: The low voltage is detected

1: The low voltage is not detected or LVD function is disabled

Bits1~0 (LVD1~LVD0): Low voltage detector level select bits

LVD1	LVD0	LVD Voltage Interrupt Level
0	0	2.3
0	1	3.3
1	0	4.0
1	1	4.5

6.3.16 Bank 0 R13: TCCCR (TCC Control Register)

Bit 7	Bit 6	Bit 5	Bit 4	Bit 3	Bit 2	Bit 1	Bit 0
0	TCCS	TS	TE	PSTE	PST2	PST1	PST0

Bit 7: Not used, fixed to “0” all the time.

Bit 6 (TCCS): TCC Clock Source Select Bit

0: Fs (sub clock)

1: Fm (main clock)

Bit 5 (TS): TCC Signal Source

0: Internal oscillator cycle clock. If P77 is used as I/O pin, TS must be “0”.

1: Transition on the TCC pin

Bit 4 (TE): TCC Signal Edge

0: Increment if the transition from low to high takes place on the TCC pin;

1: Increment if the transition from high to low takes place on the TCC pin.

Bit 3 (PSTE): Prescaler enable bit for TCC

0: Prescaler disabled, TCC rate is 1:1

1: Prescaler enabled, TCC rate is set as Bits 2~0.

Bits 2~0 (PST2~PST0): TCC Prescaler bits

PST2	PST1	PST0	TCC Rate
0	0	0	1:2
0	0	1	1:4
0	1	0	1:8
0	1	1	1:16
1	0	0	1:32
1	0	1	1:64
1	1	0	1:128
1	1	1	1:256

6.3.17 Bank 0 R14: TCCDATA (TCC Data Register)

Increase by an external signal edge through the TCC pin, or by the instruction cycle clock. External signal of TCC trigger pulse width must be greater than one instruction. The signals to increase the counter are determined by Bit 4 and Bit 5 of the TCCCR register. This register is writable and readable as any other registers.

6.3.18 Bank 0 R15~R19 (IOCR5~IOCR9)

These registers are used to control I/O port direction. They are both readable and writable.

0: Set the relative I/O pin as output

1: Set the relative I/O pin into high impedance

6.3.19 Bank 0 R1A~R1B (Not Used)

6.3.20 Bank 0 R1C: IMR1 (Interrupt Mask Register 1)

Bit 7	Bit 6	Bit 5	Bit 4	Bit 3	Bit 2	Bit 1	Bit 0
LVDIE	0	SPIE	PWMBIE	PWMAIE	EXIE	ICIE	TCIE

Bits 7 (LVDIE): LVDIF interrupt enable bit

0: Disable LVDIF interrupt

1: Enable LVDIF interrupt

Bit 6: Not used, fixed to "0" all the time.

Bit 5 (SPIE): Interrupt enable bit

0: Disable SPIF interrupt

1: Enable SPIF interrupt

Bit 4 (PWMBIE): PWMBIF interrupt enable bit

0: Disable PWMB interrupt

1: Enable PWMB interrupt

Bit 3 (PWMAIE): PWMAIF interrupt enable bit

0: Disable PWMA interrupt

1: Enable PWMA interrupt

Bit 2 (EXIE): EXIF interrupt enable bit

0: Disable EXIF interrupt

1: Enable EXIF interrupt

Bit 1 (ICIE): ICIF interrupt enable bit

0: Disable ICIF interrupt

1: Enable ICIF interrupt

Bit 0 (TCIE): TCIF interrupt enable bit

0: Disable TCIF interrupt

1: Enable TCIF interrupt

6.3.21 Bank 0 R1D: IMR2 (Interrupt Mask Register 2)

Bit 7	Bit 6	Bit 5	Bit 4	Bit 3	Bit 2	Bit 1	Bit 0
CMP2IE	CMP1IE	TC3IE	TC2IE	TC1IE	UERRIE	URIE	UTIE

Bit 7 (CMP2IE): CMP2IF interrupt enable bit

0: Disable CMP2IF interrupt

1: Enable CMP2IF interrupt

When the Comparator output status change is used to enter interrupt vector or enter the instruction, the CMP2IE bit must be set to "Enable".

Bit 6 (CMP1IE): CMP1IF interrupt enable bit

0: Disable CMP1IF interrupt

1: Enable CMP1IF interrupt

When the Comparator output status change is used to enter interrupt vector or enter the next instruction, the CMP1IE bit must be set to "Enable".

Bit 5 (TC3IE): Interrupt enable bit.

0: Disable TC3IF interrupt

1: Enable TC3IF interrupt

- Bit 4 (TC2IE):** Interrupt enable bit
0: Disable TC2IF interrupt
1: Enable TC2IF interrupt
- Bit 3 (TC1IE):** Interrupt enable bit
0: Disable TC1IF interrupt
1: Enable TC1IF interrupt
- Bit 2 (UERRIE):** UART receive error interrupt enable bit
0: Disable UERRIF interrupt
1: Enable UERRIF interrupt
- Bit 1 (URIE):** UART receive mode Interrupt enable bit
0: Disable RBFF interrupt
1: Enable RBFF interrupt
- Bit 0 (UTIE):** UART transmit mode interrupt enable bit
0: Disable TBEF interrupt
1: Enable TBEF interrupt

6.3.22 Bank 0 R1E: IMR3 (Interrupt Mask Register 3)

Bit 7	Bit 6	Bit 5	Bit 4	Bit 3	Bit 2	Bit 1	Bit 0
0	0	0	0	I2CSTPIE	0	I2CRIE	I2CTIE

Bits 7~3: Not used, fixed to “0” all the time.

Bit 3 (I2CSTPIE): I2CSTPIF interrupt enable bit.

- 0:** Disable I2CSTP interrupt
1: Enable I2CSTP interrupt

Bit 2: Not used, fixed to “0” all the time.

Bit 1 (I2CRIE): I2C Interface Rx interrupt enable bit

- 0:** Disable interrupt
1: Enable interrupt

Bit 2 (I2CTIE): I2C Interface Tx interrupt enable bit

- 0:** Disable interrupt
1: Enable interrupt

6.3.23 Bank 0 R1F (Not Used)

6.3.24 Bank 0 R20: P5WUCR (Port 5 Wake Up Control Register)

Bit 7	Bit 6	Bit 5	Bit 4	Bit 3	Bit 2	Bit 1	Bit 0
WU_P57	WU_P56	WU_P55	WU_P54	WU_P53	WU_P52	WU_P51	WU_P50

Bits 7~0 (WU_P57~WU_P50): Wake up function control for Port 5

0: Disable wake up function

1: Enable wake up function

6.3.25 Bank 0 R21: P5WUECR (Port 5 Wake-up Edge Control Register)

Bit 7	Bit 6	Bit 5	Bit 4	Bit 3	Bit 2	Bit 1	Bit 0
WUE_P57	WUE_P56	WUE_P55	WUE_P54	WUE_P53	WUE_P52	WUE_P51	WUE_P50

Bits 7~0 (WUE_P57~WUE_P50): Wake-up signal edge select for Port 5.

0: Falling edge trigger

1: Rising edge trigger

6.3.26 Bank 0 R22: P7WUCR (Port 7 Wake-up Control Register)

Bit 7	Bit 6	Bit 5	Bit 4	Bit 3	Bit 2	Bit 1	Bit 0
WU_P77	WU_P76	WU_P75	WU_P74	WU_P73	WU_P72	WU_P71	WU_P70

Bits 7~0 (WU_P77~WU_P70): Wake-up function control for Port 7.

0: Disable wake-up function

1: Enable wake-up function

6.3.27 Bank 0 R23: P7WUECR (Port 7 Wake-up Edge Control Register)

Bit 7	Bit 6	Bit 5	Bit 4	Bit 3	Bit 2	Bit 1	Bit 0
WUE_P77	WUE_P76	WUE_P75	WUE_P74	WUE_P73	WUE_P72	WUE_P71	WUE_P70

Bits 7~0 (WUE_P77~WUE_P70): Wake-up signal edge select for Port 7.

0: Falling edge trigger

1: Rising edge trigger

6.3.28 Bank 0 R24~R2A (Not Used)

6.3.29 Bank 0 R2B: SPICR (SPI Control Register)

Bit 7	Bit 6	Bit 5	Bit 4	Bit 3	Bit 2	Bit 1	Bit 0
CES	SPIE	SRO	SSE	SDOC	SBR2	SBR1	SBR0

Bit 7 (CES): Clock Edge Select bit

0: Data shifts out on a rising edge and shifts in on a falling edge. Data is on hold during low-level.

1: Data shifts out on a falling edge and shifts in on a rising edge. Data is on hold during high-level.

Bit 6 (SPIE): SPI Enable bit

0: Disable SPI mode

1: Enable SPI mode

Bit 5 (SRO): SPI Read Overflow bit

0: No overflow

1: A new data is received while the previous data is still being held in the SPIR register. Under this condition, the data in the SPI Shift register will be destroyed. To avoid setting this bit, users are required to read the SPIR register although only transmission is implemented. This can only occur in Slave mode.

Bit 4 (SSE): SPI Shift Enable bit

0: Reset as soon as shifting is completed and the next byte is ready to shift.

1: Start to shift and keep at "1" while the current byte is being transmitted.

Bit 3 (SDOC): SDO output status control bit

0: After Serial data output, the SDO remains high

1: After Serial data output, the SDO remains low

Bits 2~0 (SBR2~SBR0): SPI Baud Rate Select bits

SBR2	SBR1	SBR0	Mode	SPI Baud Rate
0	0	0	Master	Fosc/2
0	0	1	Master	Fosc/4
0	1	0	Master	Fosc/8
0	1	1	Master	Fosc/16
1	0	0	Master	Fosc/32
1	0	1	Master	Fosc/64
1	1	0	Slave	/SS enable
1	1	1	Slave	/SS disable

6.3.30 Bank0 R2C: SPIS (SPI Status Register)

Bit 7	Bit 6	Bit 5	Bit 4	Bit 3	Bit 2	Bit 1	Bit 0
DORD	TD1	TD0	0	OD3	OD4	0	RBF

Bit 7 (DORD): Data transmission order

0: Shift left (MSB first)

1: Shift right (LSB first)

Bits 6~5 (TD1~TD0): SDO status output delay time options. When CPU oscillator source uses F_s , it delays 1 CLK time.

TD1	TD0	Delay Time
0	0	8 CLK
0	1	16 CLK
1	0	24 CLK
1	1	32 CLK

Bit 4: Not used, fixed to “0” all the time.

Bit 3 (OD3): Open Drain control bit

0: Open drain disable for SDO

1: Open drain enable for SDO

Bit 2 (OD4): Open Drain control bit

0: Open drain disable for SCK

1: Open drain enable for SCK

Bit 1: Not used, fixed to “0” all the time.

Bit 0 (RBF): Read Buffer Full flag

0: Receiving not completed, and SPIR has not fully exchanged data.

1: Receiving completed, and SPIR has fully exchanged data.

6.3.31 Bank 0 R2D: SPIR (SPI Read Buffer Register)

Bit 7	Bit 6	Bit 5	Bit 4	Bit 3	Bit 2	Bit 1	Bit 0
SRB7	SRB6	SRB5	SRB4	SRB3	SRB2	SRB1	SRB0

Bits 7~0 (SRB7~SRB0): SPI Read Data Buffer

6.3.32 Bank 0 R2E: SPIW (SPI Write Buffer Register)

Bit 7	Bit 6	Bit 5	Bit 4	Bit 3	Bit 2	Bit 1	Bit 0
SWB7	SWB6	SWB5	SWB4	SWB3	SWB2	SWB1	SWB0

Bits 7~0 (SWB7~SWB0): SPI Write Data Buffer

6.3.33 Bank 0 R2F: WUCR1 (Wake-up Control Register 1)

Bit 7	Bit 6	Bit 5	Bit 4	Bit 3	Bit 2	Bit 1	Bit 0
0	SPIWE	LVDWE	ICWE	0	CMP2WE	CMP1WE	EXWE

Bit 7: Not used, fixed to “0” all the time

Bit 6 (SPIWE): SPI Wake-up enable bit. Applicable only when SPI works in Slave mode.

0: Disable SPI Wake up

1: Enable SPI Wake up.

Bit 5 (LVDWE): Low Voltage Detect Wake-up Enable bit

Bit 4 (ICWE): Port 6 Input Status Change Wake-up enable bit

0: Disable Port 6 input status change Wake-up

1: Enable Port 6 input status change Wake-up

When the Port 6 input status change is used to enter interrupt vector or to wake-up IC from Sleep/Idle mode, the ICWE bit must be set to “Enable”.

Bit 3: Not used, fixed to “0” all the time.

Bits 2~1 (CMP2WE~CMP1WE): Comparators 2~1 Wake-up enable bits

0: Disable Comparator Wake-up

1: Enable Comparator Wake-up

When the Comparators 2~1 output status change is used to enter an interrupt vector or to Wake-up the IC from Sleep, the CMPWE bit must be set to “Enable”.

Bit 0 (EXWE): External Interrupts Wake-up Function Enable bit

0: Disable external interrupt Wake-up

1: Enable external interrupt Wake-up

When the External Interrupt status changed is used to enter an interrupt vector or to Wake-up the IC from Sleep, the EXWE bits must be set to “Enable”.

6.3.34 Bank 0 R30~R31 (Not Used)

6.3.35 Bank 0 R32: URCR1 (UART Control Register 1)

Bit 7	Bit 6	Bit 5	Bit 4	Bit 3	Bit 2	Bit 1	Bit 0
URTD8	UMODE1	UMODE0	BRATE2	BRATE1	BRATE0	UTBE	TXE

Bit 7 (URTD8): UART transmit data buffer 8th bit

Bits 6~5 (UMODE1~UMODE0): UART mode select bits

UMODE1	UMODE0	UART Mode
0	0	Mode 1: 7-bit
0	1	Mode 1: 8-bit
1	0	Mode 1: 9-bit
1	1	Reserved

Bits 4~2 (BRATE2~BRATE0): Transmit baud rate selection

BRATE2	BRATE1	BRATE0	Baud Rate	8 MHz
0	0	0	Fc/13	38400
0	0	1	Fc/26	19200
0	1	0	Fc/52	9600
0	1	1	Fc/104	4800
1	0	0	Fc/208	2400
1	0	1	Fc/416	1200
1	1	0	TC3	–
1	1	1	Reserved	

Bit 1 (UTBE): UART transfer buffer empty flag. Set to “1” when transfer buffer is empty. Reset to “0” automatically when write into URTD register.

NOTE

UTBE bit is cleared by hardware when transmission is enabled, and UTBE bit is read-only. Therefore, Write URTD register is necessary when you want to start shift transmitting.

Bit 0 (TXE): Enable transmission

0: Disable transmission

1: Enable transmission

6.3.36 Bank 0 R33: URCR2 (UART Control Register 2)

Bit 7	Bit 6	Bit 5	Bit 4	Bit 3	Bit 2	Bit 1	Bit 0
0	0	SBIM1	SBIM0	UINVEN	0	0	0

Bits 7~6: Not used, fixed to “0” all the time.

Bits 5~4 (SBIM1~SBIM0): Serial bus interface operation mode select

SBIM1	SBIM0	Operation Mode
0	0	I/O mode
0	1	SPI mode
1	0	UART mode
1	1	I2C mode

Bit 3 (UINVEN): Enable UART TX and RX port inverse output

0: Disable TX and RX port inverse output

1: Enable TX and RX port inverse output

Bits 2~0: Not used, fixed to “0” all the time.

6.3.37 Bank 0 R34: URS (UART Status Register)

Bit 7	Bit 6	Bit 5	Bit 4	Bit 3	Bit 2	Bit 1	Bit 0
URRD8	EVEN	PRE	PRERR	OVERR	FMERR	URBF	RXE

Bit 7 (URRD8): UART receive data buffer 8th bit

Bit 6 (EVEN): Select parity check

0: Odd parity

1: Even parity

Bit 5 (PRE): Enable parity addition

0: Disable

1: Enable

Bit 4 (PRERR): Parity error flag. Set to “1” when parity error occurs and clear to “0” by software.

Bit 3 (OVERR): Over running error flag. Set to “1” when overrun error occurs and clear to “0” by software.

Bit 2 (FMERR): Framing error flag. Set to “1” when framing error occurs and clear to “0” by software.

Bit 1 (URBF): UART read buffer full flag. Set to “1” when one character is received. Reset to “0” automatically when read from URS register. URBF is cleared by hardware when Receive is enabled. The URBF bit is read-only. Therefore, reading the URS register is necessary to avoid overrun error.

Bit 0 (RXE): Enable Receive

0: Disable Receive

1: Enable Receive

6.3.38 Bank 0 R35: URRD (UART Receive Data Buffer Register)

Bit 7	Bit 6	Bit 5	Bit 4	Bit 3	Bit 2	Bit 1	Bit 0
URRD7	URRD6	URRD5	URRD4	URRD3	URRD2	URRD1	URRD0

Bits 7~0 (URRD7~URRD0): UART receive data buffer. Read only.

6.3.39 Bank 0 R36: URTD (UART Transmit Data Buffer Register)

Bit 7	Bit 6	Bit 5	Bit 4	Bit 3	Bit 2	Bit 1	Bit 0
URTD7	URTD6	URTD5	URTD4	URTD3	URTD2	URTD1	URTD0

Bits 7~0 (URTD7~URTD0): UART transmit data buffer. Write only.

6.3.40 Bank 0 R37: TBPTL (Table Pointer Low Register)

Bit 7	Bit 6	Bit 5	Bit 4	Bit 3	Bit 2	Bit 1	Bit 0
TB7	TB6	TB5	TB4	TB3	TB2	TB1	TB0

Bits 7~0 (TB7~TB0): Table point address Bits 7~0

6.3.41 Bank 0 R38: TBPTH (Table Pointer High Register)

Bit 7	Bit 6	Bit 5	Bit 4	Bit 3	Bit 2	Bit 1	Bit 0
HLB	GP1	GP0	TB12	TB11	TB10	TB9	TB8

Bit 7 (HLB): Take MLB or LSB at machine code

Bits 6~5 (GP1~GP0): General purpose read/write bits

Bits 4~0 (TB12~TB8): Table Pointer Address Bits 12~8.

6.3.42 Bank 0 R39: CMP1CR (Comparator 1 Control Register)

Bit 7	Bit 6	Bit 5	Bit 4	Bit 3	Bit 2	Bit 1	Bit 0
C1RS	CP1OUT	CMP1COS1	CMP1COS0	CP1NS	CP1PS	CP1NRE	CP1NRDT

Bit 7 (C1RS): Comparator input reference source select bit

0: CIN1+ source external

1: CIN1+ source internal

Bit 6 (CP1OUT): The result of comparator output

Bits 5~4 (CMP1COS1~CMP1COS0): Comparator 1/OP1 select bits

CMP1COS1	CMP1COS0	Function Description
0	0	Comparator 1 not used. P70, P71, and P72 act as normal I/O pin
0	1	P71 and P72 function as Comparator 1 input pin and P70 functions as normal I/O pin
1	0	P71 and P72 function as Comparator 1 input pin and P70 functions as Comparator 1 output pin (CO1).
1	1	Reserved

Bit 3 (CP1NS): Negative end of Comparator 1 is connected to ground.

0: Disable, P72/CIN1- functions as CIN1-

1: Enable, P72/CIN1- functions as P72

Bit 2 (CP1PS): Positive end of Comparator 1 is connected to ground.

0: Disable, P71/CIN1+ functions as CIN1+

1: Enable, P71/CIN1+ functions as P71

Bit 1 (CP1NRE): Noise Rejection Enable bit for Comparator 1

0: Disable noise rejection

1: Enable noise rejection (default)

NOTE

In Low Crystal 2 Oscillator (LXT2) mode, Green mode, and Idle mode, the noise rejection circuits are always disabled.

Bit 0 (CP1NRDT): Comparator 1 Noise Rejection Delay Time.

In Low XTAL1 oscillator (LXT1) mode, the noise rejection high/low pulse is always 4/Fm.

0: Comparator 1 output H/L pulse equal to 4/Fm (0.5μs at 8 MHz) is considered as signal.

1: Comparator 1 output H/L pulse equal to 8/Fm (1μs at 8 MHz) is considered as signal.

6.3.43 Bank 0 R3A~R3B: (Not Used)

6.3.44 Bank 0 R3C: CMP2CR (Comparator 2 Control Register)

Bit 7	Bit 6	Bit 5	Bit 4	Bit 3	Bit 2	Bit 1	Bit 0
C2RS	CP2OUT	CMP2COS1	CMP2COS0	CP2NS	CP2PS	CP2NRE	CP2NRDT

Bit 7 (C2RS): Comparator 2 input reference source select bit

0: CIN2+ source external

1: CIN2+ source internal

Bit 6 (CP2OUT): The result of Comparator 2 output

Bits 5~4 (CMP1COS1~CMP1COS0): Comparator 2/OP2 select bits

CMP2COS1	CMP2COS0	Function Description
0	0	Comparator 2 not used. P80, P81, P82 act as normal I/O pin
0	1	P81, P82, act as an Comparator 2 input pin and P80 acts as normal I/O pin
1	0	P81, P82 act as an Comparator 2 input pin and P80 acts as Comparator 2 output pin (CO2).
1	1	Reserved

Bit 3 (CP2NS): Negative end of Comparator 2 is connected to ground.

0: disable, P82/CIN2- as CIN2-.

1: enable, P82/CIN2- as P82

Bit 2 (CP2PS): Positive end of Comparator 2 is connected to ground.

0: disable, P81/CIN2+ as CIN2+.

1: enable, P81/CIN2+ as P81

Bit 1 (CP2NRE): Noise Rejection Enable bit for Comparator 2

0: Disable noise rejection

1: Enable noise rejection (default). But in Low Crystal 2 Oscillator (LXT2) mode, Green mode, and Idle mode, the noise rejection circuits are always disabled.

Bit 0 (CP2NRDT): Comparator 2 Noise Rejection Delay Time.

In Low XTAL1 oscillator (LXT1) mode, the noise rejection high/low pulse is always $4/F_m$.

0: Comparator 1 output H/L pulse equal to $4/F_m$ ($0.5 \mu s$ at 8 MHz) is considered as signal.

1: Comparator 1 output H/L pulse equal to $8/F_m$ ($1 \mu s$ at 8 MHz) is considered as signal.

6.3.45 Bank 0 R3D~R42: (Not Used)

6.3.46 Bank 0 R43: CPIRLCON (Comparator Internal Reference Level Control Register)

Bit 7	Bit 6	Bit 5	Bit 4	Bit 3	Bit 2	Bit 1	Bit 0
BG2OUT	C2IRL2	C2IRL1	C2IRL0	BG1OUT	C1IRL2	C1IRL1	C1IRL0

Bit 7 (BG2OUT): When this bit set to “1”, Pin P83 will output the bandgap reference voltage.

Bits 6~4 (C2IRL2~C2IRL0): Comparator 2 internal reference level

Bit 3 (BG1OUT): When this bit set to “1”, Pin P73 will output the bandgap reference voltage

Bits 2~0 (C1IRL2~C1IRL0): Comparator 1 internal reference level

CxIRL2	CxIRL1	CxIRL0	Voltage Level(V)
0	0	0	0.5
0	0	1	0.8
0	1	0	1.0
0	1	1	1.5
1	0	0	2.0
1	0	1	2.2
1	1	0	2.5
1	1	1	3.0

6.3.47 Bank 0 R44~R47: (Not Used)

6.3.48 Bank 0 R48: TC1CR (Timer 1 Control Register)

Bit 7	Bit 6	Bit 5	Bit 4	Bit 3	Bit 2	Bit 1	Bit 0
TC1CAP	TC1S	TC1CK1	TC1CK0	TC1M	TC1ES	0	0

Bit 7 (TC1CAP): Software capture control

0: Software capture control disabled

1: Software capture control enabled

Bit 6 (TC1S): Timer/Counter 1 start control

0: Stop and clear counter

1: Start timer/counter

Bits 5~4 (TC1CK1~TC1CK0): Timer/Counter 1 clock source select bits

TC1CK1	TC1CK0	Clock Source	Resolution 8 MHz	Max. Time 8 MHz	Resolution 16kHz	Max. Time 16kHz
		Normal	FC=8M	FC=8M	FC=16K	FC=16K
0	0	$FC/2^{12}$	512 μ s	131072 μ s	256 ms	65536 ms
0	1	$FC/2^{10}$	128 μ s	32768 μ s	64 ms	16384 ms
1	0	$FC/2^7$	16 μ s	4096 μ s	8 ms	2048 ms
1	1	External clock (TC1 pin)	-	-	-	-

Bit 3 (TC1M): Timer/Counter 1 mode select

- 0: Timer/Counter 1 mode
- 1: Capture mode

Bit 2 (TC1ES): Timer/Counter 1 signal edge

- 0: Increment if the transition from low to high (rising edge) take place on TC1 pin.
- 1: increment if the transition from high to low (falling edge) take place on TC1 pin.

Bits 1~0: Not used, fixed to "0" all the time.

■ **Timer/Counter 1 Configuration**

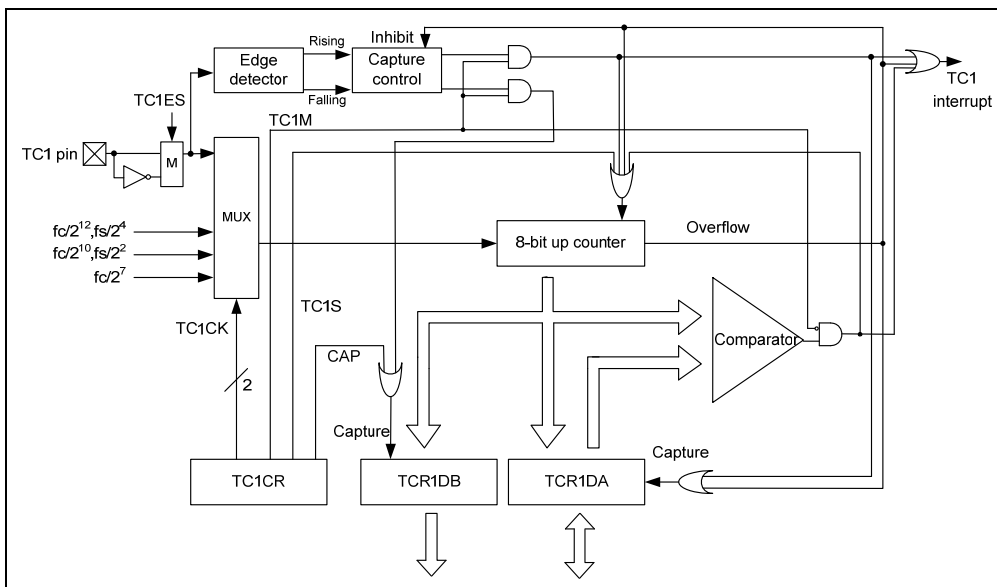

Figure 6-8a Timer/Counter 1 Configuration Block Diagram

In **Timer mode**, counting up is performed using internal clock. When the contents of up-counter match the TCR1DA, interrupt is then generated and the counter is cleared. Counting up resumes after the counter is cleared. The current contents of the up-counter are loaded into TCR1DB by setting TC1CAP to “1” and the TC1CAP is cleared to “0” after capture is completed automatically.

In **Counter mode**, counting up is performed using external clock input pin (TC1 pin) and either rising or falling edge can be selected by TC1ES, but **both edges cannot be used**. When the contents of up-counter match the TCR1DA, interrupt is then generated and the counter is cleared. Counting up resumes after the counter is cleared. The current contents of the up-counter are loaded into TCR1DB by setting TC1CAP to “1” and the TC1CAP is cleared to “0” after capture is completed automatically.

In **Capture mode**, the pulse width, period, and duty of the TC1 input pin are measured under this mode to decode the remote control signal. The counter is made free running by the internal clock. On the rising (falling) edge of TC1 pin input, the contents of the counter are loaded into TCR1DA, then the counter is cleared and interrupt is generated. On the falling (rising) edge of TC1 pin input, the contents of the counter are loaded into TCR1DB. At the next rising edge of TC1 pin input while the counter is still counting, the contents of the counter are loaded into TCR1DA. Then the counter is cleared and interrupt is generated again. If an overflow is detected before the edge, FFH is loaded into TCR1DA and an overflow interrupt is generated. During the interrupt process, user can check and determine whether an overflow has occurred by checking if the TCR1DA value is FFH. After an interrupt (capture to TCR1DA or overflow detected) is generated, capture and overflow detection are halted until TCR1DA is read out.

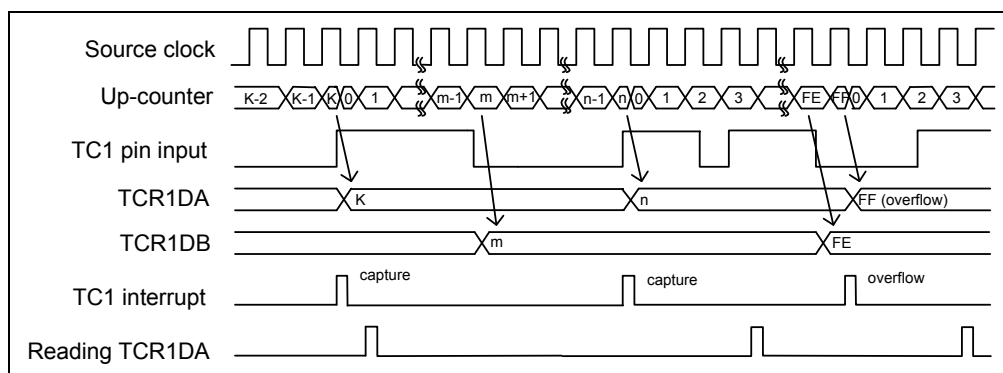

Figure 6-8b Capture Mode Timing Diagram

6.3.49 Bank 0 R49: TCR1DA (Timer 1 Data Buffer A)

Bit 7	Bit 6	Bit 5	Bit 4	Bit 3	Bit 2	Bit 1	Bit 0
TCR1DA7	TCR1DA6	TCR1DA5	TCR1DA4	TCR1DA3	TCR1DA2	TCR1DA1	TCR1DA0

Bits 7~0 (TCR1DA7~TCR1DA0): 8-bit Timer/Counter 1 of Data Buffer A

6.3.50 Bank 0 R4A: TCR1DB (Timer 1 Data Buffer B)

Bit 7	Bit 6	Bit 5	Bit 4	Bit 3	Bit 2	Bit 1	Bit 0
TCR1DB7	TCR1DB6	TCR1DB5	TCR1DB4	TCR1DB3	TCR1DB2	TCR1DB1	TCR1DB0

Bits 7~0 (TCR1DB7~TCR1DB0): 8-bit Timer/Counter 1 of Data Buffer B

6.3.51 Bank 0 R4B: TC2CR (Timer 2 Control Register)

Bit 7	Bit 6	Bit 5	Bit 4	Bit 3	Bit 2	Bit 1	Bit 0
0	0	TC2ES	TC2M	TC2S	TC2CK2	TC2CK1	TC2CK0

Bits 7~6: Not used, fixed to "0" all the time.

Bit 5 (TC2ES): TC2 signal edge

0: Increment if the transition from low to high (rising edge) takes place on TC2 pin

1: Increment if the transition from high to low (falling edge) takes place on TC2 pin

Bit 4 (TC2M): Timer/Counter2 mode select

0: Timer/Counter 2 mode

1: Window mode

Bit 3 (TC2S): Timer/Counter 2 start control

0: Stop and clear counter

1: Start timer/counter

Bits 2~0 (TC2CK2~TC2CK0): Timer/Counter 2 clock source select

TC2CK2	TC2CK1	TC1CK0	Clock Source	Resolution 8 MHz	Max time 8 MHz	Resolution 16kHz	Max time 16kHz
			Normal	$F_c=8M$	$F_c=8M$	$F_c=16K$	$F_c=16K$
0	0	0	$F_c/2^{23}$	1.05s	19.1hr	145hr	9544hr
0	0	1	$F_c/2^{13}$	1.024ms	66.21s	512ms	33554.432s
0	1	0	$F_c/2^8$	32 μ s	2.097s	16ms	1048.576s
0	1	1	$F_c/2^3$	1 μ s	65.536ms	0.5ms	32768ms
1	0	0	F_c	125ns	8.192ms	0.0625ms	4096ms
1	0	1	-	-	-	-	-
1	1	0	-	-	-	-	-
1	1	1	External clock (TC2 pin)	-	-	-	-

■ Timer/Counter 2 Configuration

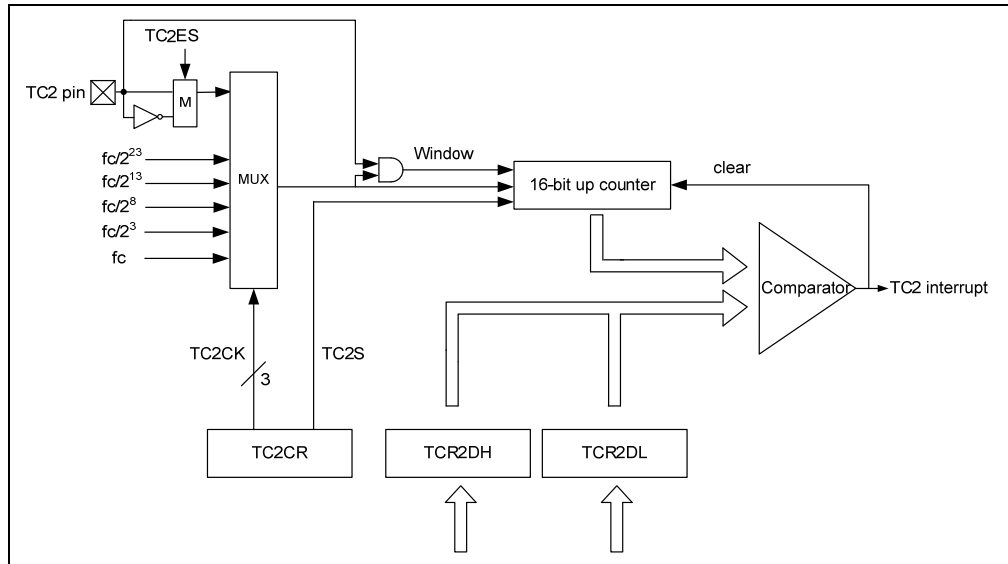

Figure 6-9a Timer/Counter 2 Configuration Block Diagram

In Timer mode, counting up is performed using internal clock. When the contents of the up-counter match the TCR2 (TCR2H+TCR2L), interrupt is then generated and the counter is cleared. Counting up resumes after the counter is cleared.

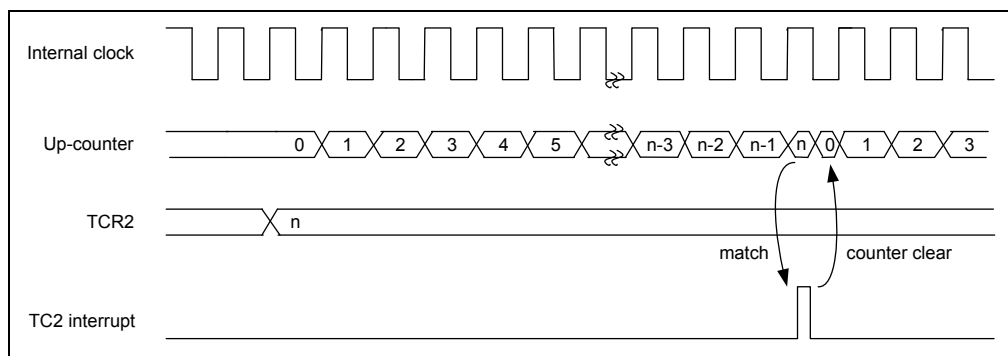

Figure 6-9b Timer Mode Timing Diagram

In Counter mode, counting up is performed using external clock input pin (TC2 pin) and either rising or falling edge can be select by setting TC2ES. When the contents of the up-counter match the TCR2 (TCR2H+TCR2L), interrupt is then generated and the counter is cleared. Counting up resumes after the counter is cleared.

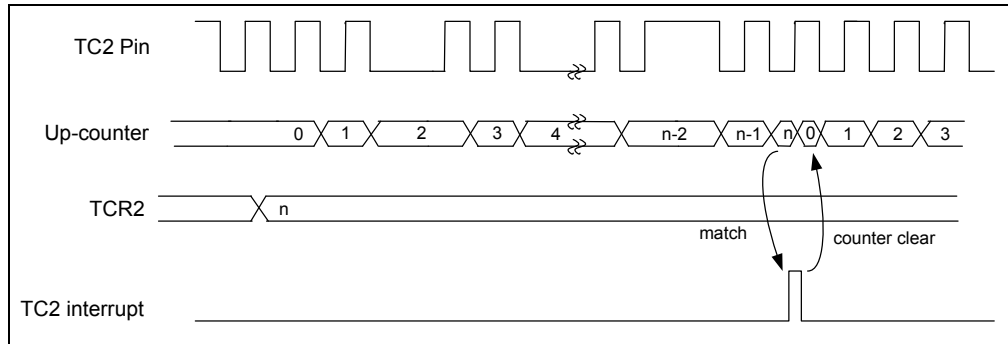

Figure 6-9c Counter Mode Timing ($INT2ES = 1$) Diagram

In Window mode, counting up is performed on rising edge of the pulse that is logical AND of an internal clock and of the TC2 pin (window pulse). When the contents of up-counter match the TCR2 ($TCR2H+TCR2L$), the interrupt is then generated and the counter is cleared. **The frequency (window pulse) must be slower than the selected internal clock.**

When writing to the TCR2L, the comparison is inhibited until TCR2H is written.

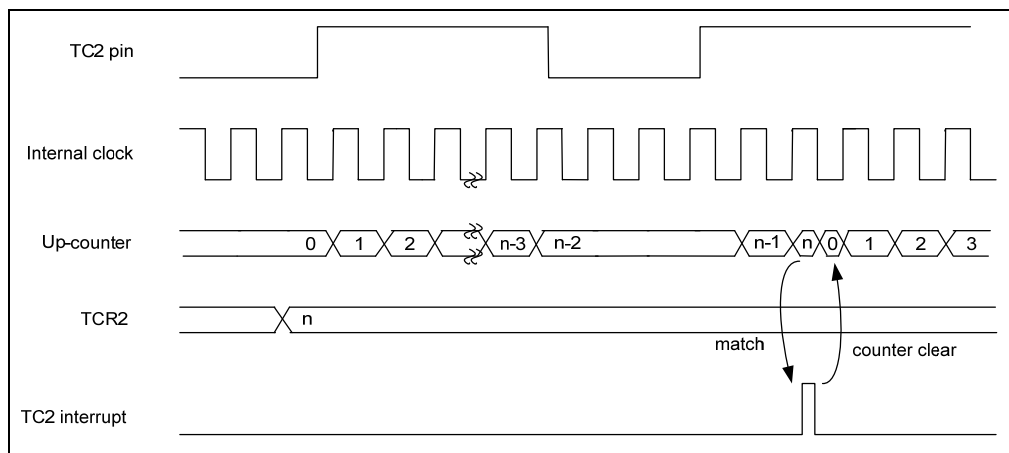

Figure 6-9d Window Mode Timing Diagram

6.3.52 Bank 0 R4C: TCR2DH (Timer 2 High Byte Data Buffer Register)

Bit 7	Bit 6	Bit 5	Bit 4	Bit 3	Bit 2	Bit 1	Bit 0
TCR2D15	TCR2D14	TCR2D13	TCR2D12	TCR2D11	TCR2D10	TCR2D9	TCR2D8

Bits 7~0 (TCR2D15~ TCR2D8): 16-bit Timer/Counter 2 of high byte data buffer

6.3.53 Bank 0 R4D: TCR2DL (Timer 2 Low Byte Data Buffer Register)

Bit 7	Bit 6	Bit 5	Bit 4	Bit 3	Bit 2	Bit 1	Bit 0
TCR2D7	TCR2D6	TCR2D5	TCR2D4	TCR2D3	TCR2D2	TCR2D1	TCR2D0

Bits 7~0 (TCR2D7~TCR2D0): 16-bit Timer/Counter 2 of low byte data buffer

6.3.54 Bank 0 R4E: TC3CR (Timer 3 Control Register)

Bit 7	Bit 6	Bit 5	Bit 4	Bit 3	Bit 2	Bit 1	Bit 0
TC3FF1	TC3FF0	TC3S	TC3CK2	TC3CK1	TC3CK0	TC3M1	TC3M0

Bits 7~6 (TC3FF1~TC3FF0): Timer/Counter 3 flip-flop control

TC3FF1	TC3FF0	Operating Mode
0	0	Clear
0	1	Toggle
1	0	Set
1	1	Reserved

Bit 5 (TC3S): Timer/Counter 3 start control

0: Stop and clear counter

1: Start timer/counter

Bits 4~2 (TC3CK2~TC3CK0): Timer/Counter 3 clock source select

TC3CK2	TC3CK1	TC3CK0	Clock Source	Resolution 8 MHz	Max Time 8 MHz	Resolutio n 16kHz	Max Time 16kHz
			Normal	FC=8M	FC=8M	FC=16K	FC=16K
0	0	0	FC/211	256μs	65536μs	128ms	32768ms
0	0	1	FC/27	16μs	4096μs	8ms	2048ms
0	1	0	FC/25	4μs	1024μs	2ms	512ms
0	1	1	FC/23	1μs	256μs	500μs	128ms
1	0	0	FC/22	500ns	128μs	250μs	64ms
1	0	1	FC/2	250ns	64μs	125μs	32ms
1	1	0	FC	125ns	32μs	62.5μs	16ms
1	1	1	External clock (TC3 pin)	-	-	-	-

Bits 1~0 (TC3M1~TC3M0): Timer/Counter 3 operation mode select.

TC3M1	TC3M0	Operating Mode
0	0	Timer/Counter
0	1	Reserved
1	0	Programmable Divider output
1	1	Pulse Width Modulation output

■ Timer/Counter 3 Configuration

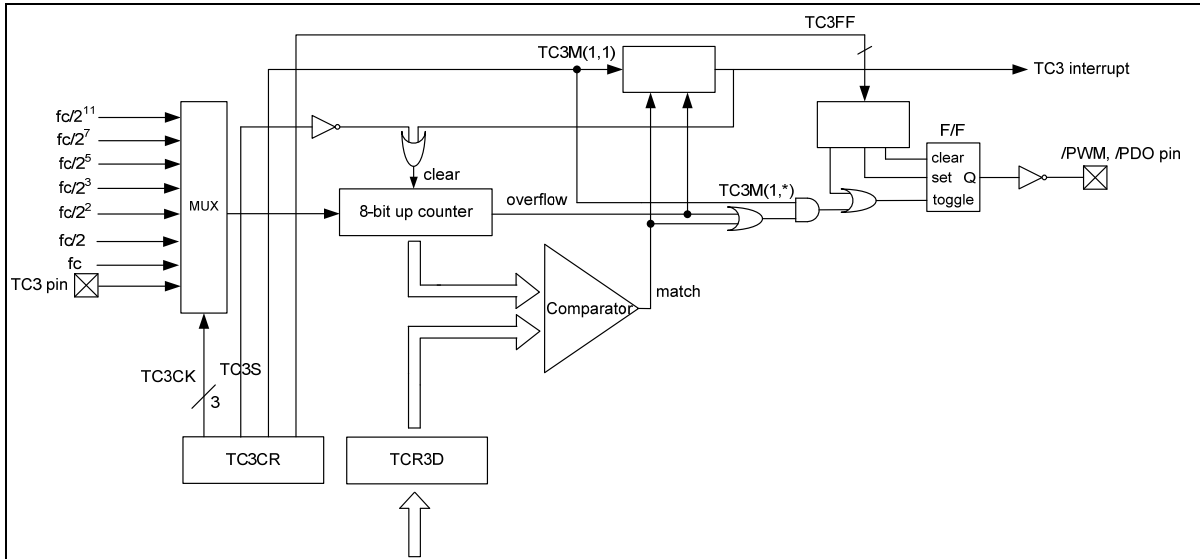

Figure 6-10a Timer/Counter3 Configuration Block Diagram

In Timer mode, counting up is performed using the internal clock (rising edge trigger). When the contents of up-counter match the TCR3D, the interrupt is generated and the counter is then cleared. Counting up resumes after the counter is cleared.

In Counter mode, counting up is performed using the external clock input pin (TC3 pin). When the contents of up-counter match the TCR3D, interrupt is generated and the counter is then cleared. Counting up resumes after the counter is cleared.

In Programmable Divider Output (PDO) mode, counting up is performed using the internal clock. The contents of TCR3D are compared with the contents of up-counter. The F/F output is toggled and the counter is cleared each time a match is found. The F/F output is inverted and output to /PDO pin. This mode can generate 50% duty pulse output. **The F/F can be initialized by programming and it is initialized to “0” during a reset.** A TC3 interrupt is generated each time the /PDO output is toggled.

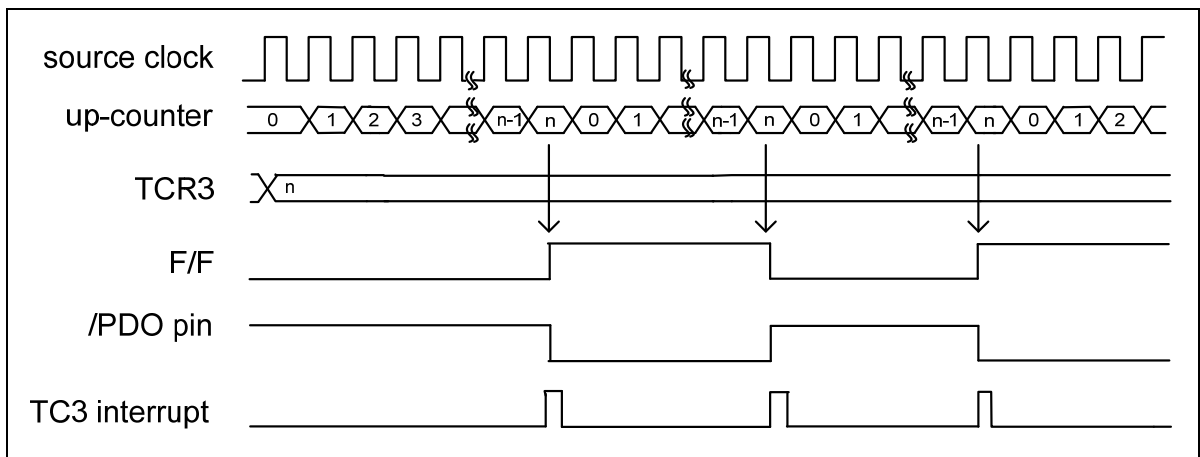

Figure 6-10b PDO Mode Timing Diagram

In Pulse Width Modulation (PWM) Output mode, counting up is performed using internal clock. The contents of TCR3 are compared with the contents of up-counter. The F/F is toggled when match is found. While the counter continues counting, the F/F is toggled again when counter overflow occurs, then counter is cleared. The F/F output is inverted and output to /PWM pin. A TC3 interrupt is generated each time an overflow occurs. **TCR3 is configured as 2-stage shift register and, during output, will not switch until one output cycle is completed even if TCR3 is overwritten.** Therefore, the output can be changed continuously. TCR3 is also shifted for the first time by setting TC3S to “1” after data is loaded to TCR3.

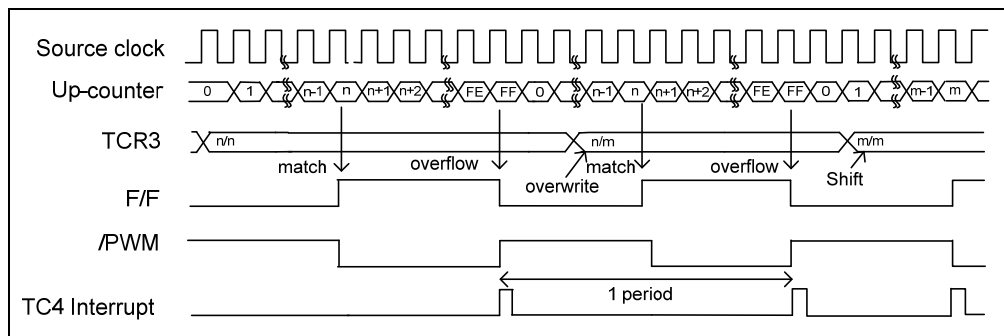

Figure 6-10c PWM Mode Timing Diagram

6.3.55 Bank 0 R4F: TCR3D (Timer 3 Duty Buffer Register)

Bit 7	Bit 6	Bit 5	Bit 4	Bit 3	Bit 2	Bit 1	Bit 0
TCR3D7	TCR3D6	TCR3D5	TCR3D4	TCR3D3	TCR3D2	TCR3D1	TCR3D0

Bits 7~0 (TCR3DB7~TCR13DB0): 8-bit Timer/Counter 3 of duty data buffer

6.3.56 Bank 1 R5: P5PHCR (Port 5 Pull High Control Register)

Bit 7	Bit 6	Bit 5	Bit 4	Bit 3	Bit 2	Bit 1	Bit 0
/PH57	/PH56	/PH55	/PH54	/PH53	/PH52	/PH51	/PH50

Bit 7 (/PH57): Control bit used to enable pull high of the P57 pin

0: Enable internal pull-high

1: Disable internal pull-high

Bit 6 (/PH56): Control bit used to enable pull high of the P56 pin

Bit 5 (/PH55): Control bit used to enable pull high of the P55 pin

Bit 4 (/PH54): Control bit used to enable pull high of the P54 pin

Bit 3 (/PH53): Control bit used to enable pull high of the P53 pin

Bit 2 (/PH52): Control bit used to enable pull high of the P52 pin

Bit 1 (/PH51): Control bit used to enable pull high of the P51 pin

Bit 0 (/PH50): Control bit used to enable pull high of the P50 pin

6.3.57 Bank 1 R6: P6PHCR (Port 6 Pull High Control Register)

Bit 7	Bit 6	Bit 5	Bit 4	Bit 3	Bit 2	Bit 1	Bit 0
/PH67	/PH66	/PH65	/PH64	/PH63	/PH62	/PH61	/PH60

Bit 7 (/PH67): Control bit used to enable pull high of the P67 pin
0: Enable internal pull-high
1: Disable internal pull-high

Bit 6 (/PH66): Control bit used to enable pull high of the P66 pin

Bit 5 (/PH65): Control bit used to enable pull high of the P65 pin

Bit 4 (/PH64): Control bit used to enable pull high of the P64 pin

Bit 3 (/PH63): Control bit used to enable pull high of the P63 pin

Bit 2 (/PH62): Control bit used to enable pull high of the P62 pin

Bit 1 (/PH61): Control bit used to enable pull high of the P61 pin

Bit 0 (/PH60): Control bit used to enable pull high of the P60 pin

6.3.58 Bank 1 R7: P7PHCR (Port 7 Pull High Control Register)

Bit 7	Bit 6	Bit 5	Bit 4	Bit 3	Bit 2	Bit 1	Bit 0
/PH77	/PH76	/PH75	/PH74	/PH73	/PH72	/PH71	/PH70

Bit 7 (/PH77): Control bit used to enable pull high of the P77 pin
0: Enable internal pull-high
1: Disable internal pull-high

Bit 6 (/PH76): Control bit used to enable pull high of the P76 pin

Bit 5 (/PH75): Control bit used to enable pull high of the P75 pin

Bit 4 (/PH74): Control bit used to enable pull high of the P74 pin

Bit 3 (/PH73): Control bit used to enable pull high of the P73 pin

Bit 2 (/PH72): Control bit used to enable pull high of the P72 pin

Bit 1 (/PH71): Control bit used to enable pull high of the P71 pin

Bit 0 (/PH70): Control bit used to enable pull high of the P70 pin

6.3.59 Bank 1 R8: P8PHCR (Port 8 Pull High Control Register)

Bit 7	Bit 6	Bit 5	Bit 4	Bit 3	Bit 2	Bit 1	Bit 0
/PH87	/PH86	/PH85	/PH84	/PH83	/PH82	/PH81	/PH80

Bit 7 (/PH87): Control bit used to enable pull high of the P87 pin
0: Enable internal pull-high
1: Disable internal pull-high

Bit 6 (/PH86): Control bit used to enable pull high of the P86 pin

Bit 5 (/PH85): Control bit used to enable pull high of the P85 pin

Bit 4 (/PH84): Control bit used to enable pull high of the P84 pin

Bit 3 (/PH83): Control bit used to enable pull high of the P83 pin

Bit 2 (/PH82): Control bit used to enable pull high of the P82 pin

Bit 1 (/PH81): Control bit used to enable pull high of the P81 pin

Bit 0 (/PH80): Control bit used to enable pull high of the P80 pin

6.3.60 Bank 1 R9: P9PHCR (Port 9 Pull High Control Register)

Bit 7	Bit 6	Bit 5	Bit 4	Bit 3	Bit 2	Bit 1	Bit 0
/PH97	/PH96	/PH95	/PH94	/PH93	/PH92	/PH91	/PH90

Bit 7 (/PH97): Control bit used to enable pull high of the P97 pin

0: Enable internal pull-high

1: Disable internal pull-high

Bit 6 (/PH96): Control bit used to enable pull high of the P96 pin

Bit 5 (/PH95): Control bit used to enable pull high of the P95 pin

Bit 4 (/PH94): Control bit used to enable pull high of the P94 pin

Bit 3 (/PH93): Control bit used to enable pull high of the P93 pin

Bit 2 (/PH92): Control bit used to enable pull high of the P92 pin

Bit 1 (/PH91): Control bit used to enable pull high of the P91 pin

Bit 0 (/PH90): Control bit used to enable pull high of the P90 pin

6.3.61 Bank 1 RA (Not Used)

6.3.62 Bank 1 RB: P5PLCR (Port 5 Pull Low Control Register)

Bit 7	Bit 6	Bit 5	Bit 4	Bit 3	Bit 2	Bit 1	Bit 0
/PL57	/PL56	/PL55	/PL54	/PL53	/PL52	/PL51	/PL50

Bit 7 (/PL57): Control bit used to enable pull low of the P57 pin

0: Enable internal pull-high

1: Disable internal pull-high

Bit 6 (/PL56): Control bit used to enable pull low of the P56 pin

Bit 5 (/PL55): Control bit used to enable pull low of the P55 pin

Bit 4 (/PL54): Control bit used to enable pull low of the P54 pin

Bit 3 (/PL53): Control bit used to enable pull low of the P53 pin

Bit 2 (/PL52): Control bit used to enable pull low of the P52 pin

Bit 1 (/PL51): Control bit used to enable pull low of the P51 pin

Bit 0 (/PL50): Control bit used to enable pull low of the P50 pin

6.3.63 Bank 1 RC: P6PLCR (Port 6 Pull Low Control Register)

Bit 7	Bit 6	Bit 5	Bit 4	Bit 3	Bit 2	Bit 1	Bit 0
/PL67	/PL66	/PL65	/PL64	/PL63	/PL62	/PL61	/PL60

Bit 7 (/PL67): Control bit used to enable pull low of the P67 pin

0: Enable internal pull-high

1: Disable internal pull-high

Bit 6 (/PL66): Control bit used to enable pull low of the P66 pin

Bit 5 (/PL65): Control bit used to enable pull low of the P65 pin

Bit 4 (/PL64): Control bit used to enable pull low of the P64 pin

Bit 3 (/PL63): Control bit used to enable pull low of the P63 pin

Bit 2 (/PL62): Control bit used to enable pull low of the P62 pin

Bit 1 (/PL61): Control bit used to enable pull low of the P61 pin

Bit 0 (/PL60): Control bit used to enable pull low of the P60 pin

6.3.64 Bank 1 RD: P7PLCR (Port 7 Pull Low Control Register)

Bit 7	Bit 6	Bit 5	Bit 4	Bit 3	Bit 2	Bit 1	Bit 0
/PL77	/PL76	/PL75	/PL74	/PL73	/PL72	/PL71	/PL70

Bit 7 (/PL77): Control bit used to enable pull low of the P77 pin

0: Enable internal pull-high

1: Disable internal pull-high

Bit 6 (/PL76): Control bit used to enable pull low of the P76 pin

Bit 5 (/PL75): Control bit used to enable pull low of the P75 pin

Bit 4 (/PL74): Control bit used to enable pull low of the P74 pin

Bit 3 (/PL73): Control bit used to enable pull low of the P73 pin

Bit 2 (/PL72): Control bit used to enable pull low of the P72 pin

Bit 1 (/PL71): Control bit used to enable pull low of the P71 pin

Bit 0 (/PL70): Control bit used to enable pull low of the P70 pin

6.3.65 Bank 1 RE: P8PLCR (Port 8 Pull Low Control Register)

Bit 7	Bit 6	Bit 5	Bit 4	Bit 3	Bit 2	Bit 1	Bit 0
/PL87	/PL86	/PL85	/PL84	/PL83	/PL82	/PL81	/PL80

Bit 7 (/PL87): Control bit used to enable pull low of the P87 pin

0: Enable internal pull-high

1: Disable internal pull-high

Bit 6 (/PL86): Control bit used to enable pull low of the P86 pin

Bit 5 (/PL85): Control bit used to enable pull low of the P85 pin

Bit 4 (/PL84): Control bit used to enable pull low of the P84 pin

Bit 3 (/PL83): Control bit used to enable pull low of the P83 pin

Bit 2 (/PL82): Control bit used to enable pull low of the P82 pin

Bit 1 (/PL81): Control bit used to enable pull low of the P81 pin

Bit 0 (/PL80): Control bit used to enable pull low of the P80 pin

6.3.66 Bank 1 RF: P9PLCR (Port 9 Pull Low Control Register)

Bit 7	Bit 6	Bit 5	Bit 4	Bit 3	Bit 2	Bit 1	Bit 0
/PL97	/PL96	/PL95	/PL94	/PL93	/PL92	/PL91	/PL90

Bit 7 (/PL97): Control bit used to enable the pull low of P97 pin

0: Enable internal pull-high

1: Disable internal pull-high

Bit 6 (/PL96): Control bit used to enable pull low of the P96 pin

Bit 5 (/PL95): Control bit used to enable pull low of the P95 pin

Bit 4 (/PL94): Control bit used to enable pull low of the P94 pin

Bit 3 (/PL93): Control bit used to enable pull low of the P93 pin

Bit 2 (/PL92): Control bit used to enable pull low of the P92 pin

Bit 1 (/PL91): Control bit used to enable pull low of the P91 pin

Bit 0 (/PL90): Control bit used to enable pull low of the P90 pin

6.3.67 Bank 1 R10 (Not Used)

6.3.68 Bank 1 R11: P5HD/SCR (Port 5 High Drive/Sink Control Register)

Bit 7	Bit 6	Bit 5	Bit 4	Bit 3	Bit 2	Bit 1	Bit 0
/H57	/H56	/H55	/H54	/H53	/H52	/H51	/H50

Bits 7~0 (/H57~H50): P57~P50 high drive/sink current control bits

0: Enable high drive/sink

1: Disable high drive/sink

6.3.69 Bank 1 R12: P6HD/SCR (Port 6 High Drive/Sink Control Register)

Bit 7	Bit 6	Bit 5	Bit 4	Bit 3	Bit 2	Bit 1	Bit 0
/H67	/H66	/H65	/H64	/H63	/H62	/H61	/H60

Bits 7~0 (/H67~/H60): P67~P60 high drive/sink current control bits

0: Enable high drive/sink

1: Disable high drive/sink

6.3.70 Bank 1 R13: P7HD/SCR (Port 7 High Drive/Sink Control Register)

Bit 7	Bit 6	Bit 5	Bit 4	Bit 3	Bit 2	Bit 1	Bit 0
/H77	/H76	/H75	/H74	/H73	/H72	/H71	/H70

Bits 7~0 (/H77~/H70): P77~P70 high drive/sink current control bits

0: Enable high drive/sink

1: Disable high drive/sink

6.3.71 Bank 1 R14: P8HD/SCR (Port 8 High Drive/Sink Control Register)

Bit 7	Bit 6	Bit 5	Bit 4	Bit 3	Bit 2	Bit 1	Bit 0
/H87	/H86	/H85	/H84	/H83	/H82	/H81	/H80

Bits 7~0 (/H87~/H80): P87~P80 high drive/sink current control bits

0: Enable high drive/sink

1: Disable high drive/sink

6.3.72 Bank 1 R15: P9HD/SCR (Port 9 High Drive/Sink Control Register)

Bit 7	Bit 6	Bit 5	Bit 4	Bit 3	Bit 2	Bit 1	Bit 0
/H97	/H96	/H95	/H94	/H93	/H92	/H91	/H90

Bits 7~0 (/H97~/H90): P97~P90 high drive/sink current control bits

0: Enable high drive/sink

1: Disable high drive/sink

6.3.73 Bank 1 R16 (Not Used)

6.3.74 Bank 1 R17: P5ODCR (Port 5 Open Drain Control Register)

Bit 7	Bit 6	Bit 5	Bit 4	Bit 3	Bit 2	Bit 1	Bit 0
OD57	OD56	OD55	OD54	OD53	OD52	OD51	OD50

Bits 7~0 (OD57~OD50): Open-Drain control bits

0: Disable open-drain function

1: Enable open-drain function

6.3.75 Bank 1 R18: P6ODCR (Port 6 Open Drain Control Register)

Bit 7	Bit 6	Bit 5	Bit 4	Bit 3	Bit 2	Bit 1	Bit 0
OD67	OD66	OD65	OD64	OD63	OD62	OD61	OD60

Bits 7~0 (OD67~OD60): Open-Drain control bits

0: Disable open-drain function

1: Enable open-drain function

6.3.76 Bank 1 R19: P7ODCR (Port 7 Open Drain Control Register)

Bit 7	Bit 6	Bit 5	Bit 4	Bit 3	Bit 2	Bit 1	Bit 0
OD77	OD76	OD75	OD74	OD73	OD72	OD71	OD70

Bits 7~0 (OD77~OD70): Open-Drain control bits

0: Disable open-drain function

1: Enable open-drain function

6.3.77 Bank 1 R1A: P8ODCR (Port 8 Open Drain Control Register)

Bit 7	Bit 6	Bit 5	Bit 4	Bit 3	Bit 2	Bit 1	Bit 0
OD87	OD86	OD85	OD84	OD83	OD82	OD81	OD80

Bits 7~0 (OD87~OD80): Open-Drain control bits

0: Disable open-drain function

1: Enable open-drain function

6.3.78 Bank 1 R1B: P9ODCR (Port 9 Open Drain Control Register)

Bit 7	Bit 6	Bit 5	Bit 4	Bit 3	Bit 2	Bit 1	Bit 0
OD97	OD96	OD95	OD94	OD93	OD92	OD91	OD90

Bits 7~0 (OD97~OD90): Open-Drain control bits

0: Disable open-drain function

1: Enable open-drain function

6.3.79 Bank 1 R1C (Not Used)

6.3.80 Bank 1 R1D: IRCS (IRC Frequency Selection Register)

Bit 7	Bit 6	Bit 5	Bit 4	Bit 3	Bit 2	Bit 1	Bit 0
0	0	RCM1	RCM0	0	0	0	0

Bits 7~6: Not used, fixed to "0" all the time.

Bits 5~4 (RCM1 ~ RCM0): IRC Mode Frequency select bits

RCM 1	RCM 0	Frequency (MHz)
0	0	4
0	1	16
1	0	8
1	1	455kHz

Word 1 COBS0 = 0: The R1D<5, 4> of the initialized values will be kept the same as Word 1<6,5>.

The R1D<5, 4> can't be changed.

Word 1 COBS0 = 1: The R1D<5, 4> of the initialized values will be kept the same as Word 1<6,5>.

The R1D<5, 4> can be changed if user wants to work on other IRC frequency.

Ex: 4M →16M

Bits 3~0: Not used, fixed to "0" all the time.

6.3.81 Bank 1 R1E (Not Used)

6.3.82 Bank 1 R1F: EEPROM Control

Bit 7	Bit 6	Bit 5	Bit 4	Bit 3	Bit 2	Bit 1	Bit 0
RD	WR	EEWE	EEDF	EEPC	0	0	0

Bit 7 (RD): Read control bit

0: Don't execute EEPROM read

1: Read EEPROM contents (RD can be set by software. When Read instruction is completed, RD will be cleared by hardware.)

Bit 6 (WR): Write control bit

0: Write cycle to the EEPROM is completed.

1: Initiate a Write cycle (WR can be set by software. When Write cycle is completed, WR will be cleared by hardware.)

Bit 5 (EEWE): EEPROM Write enable bit

0: Prohibit Write to the EEPROM

1: Allow EEPROM Write cycles

Bit 4 (EEDF): EEPROM Detect flag

0: Write cycle is completed

1: Write cycle is uncompleted

Bit 3 (EEPC): EEPROM power down control bit

0: Switch OFF EEPROM

1: EEPROM is operating

Bits 2~0: Not used, fixed to "0" all the time.

NOTE

The **EM78F548N** currently does not support EEPROM function. Therefore, the corresponding control registers (Bank 1 R1F~R21) are reserved.

6.3.83 Bank 1 R20: EEPROM ADDR

Bit 7	Bit 6	Bit 5	Bit 4	Bit 3	Bit 2	Bit 1	Bit 0
EERA7	EERA6	EERA5	EERA4	EERA3	EERA2	EERA1	EERA0

Bits 7~0 (EERA7~EERA0): EEPROM address register

NOTE

The **EM78F548N** currently does not support EEPROM function. Therefore, the corresponding control registers (Bank 1 R1F~R21) are reserved.

6.3.84 Bank 1 R21: EEPROM DATA

Bit 7	Bit 6	Bit 5	Bit 4	Bit 3	Bit 2	Bit 1	Bit 0
EERD7	EERD6	EERD5	EERD4	EERD3	EERD2	EERD1	EERD0

Bits 7~0 (EERD7~EERD0): EEPROM data register. Read only.

NOTE

The **EM78F548N** currently does not support EEPROM function. Therefore, the corresponding control registers (Bank 1 R1F~R21) are reserved.

6.3.85 Bank1 R22 (Not Used)

6.3.86 Bank1 R23: I2CCR1 (I2C Status and Control Register 1)

Bit 7	Bit 6	Bit 5	Bit 4	Bit 3	Bit 2	Bit 1	Bit 0
Strobe/Pend	IMS	ISS	STOP	SAR_EMPTY	ACK	FULL	EMPTY

Bit 7 (Strobe/Pend): In Master mode, it is used as strobe signal to control I2C circuit in sending SCL clock. Automatically resets after receiving or transmitting handshake signal (ACK or NACK). In Slave mode, it is used as pending signal. You should clear it after filling data into Tx buffer or taking data from Rx buffer to inform the Slave I2C circuit to release SCL signal.

- Bit 6 (IMS):** I2C Master/Slave mode select bit.
0: Slave
1: Master
- Bit 5 (ISS):** I2C Fast/Standard mode select bit (If Fm is 4MHz and I2CTS1~0<0,0>)
0: Standard mode (100K bit/s)
1: Fast mode (400K bit/s)
- Bit 4 (STOP):** In Master mode, if STOP=1 and R/nW=1, then EM78F648N/F548N must return an nACK signal to the Slave device before sending a STOP signal. If STOP=1 and R/nW=0, then EM78F648N/F548N sends a STOP signal after receiving an ACK signal. Resets when EM78F648N/F548N sends a STOP signal to the Slave device. In Slave mode, if STOP=1 and R/nW=0, then EM78F648N/F548N must return an nACK signal to the Master device.
- Bit 3 (SAR_EMPTY):** Set when EM78F648N/F548N transmits 1 byte data from I2C Slave Address Register and receive an ACK (or nACK) signal. Reset when the MCU writes 1 byte data to the I2C Slave Address Register.
- Bit 2 (ACK):** The ACK condition bit is set to “1” by hardware when the device responds acknowledge (ACK). Resets when the device responds with a “not-acknowledge” (nACK) signal.
- Bit 1 (FULL):** Set by hardware when I2C Receive (Rx) Buffer register is full. Resets by hardware when MCU reads data from I2C Receive (Rx) Buffer register.
- Bit 0 (EMPTY):** Set by hardware when I2C Transmit (Tx) Buffer register is empty and receive ACK (or nACK) signal. Reset by hardware when MCU writes new data to I2C Transmit (Tx) Buffer register.

6.3.87 Bank 1 R24: I2CCR2 (I2C Status and Control Register2)

Bit 7	Bit 6	Bit 5	Bit 4	Bit 3	Bit 2	Bit 1	Bit 0
I2CBF	GCEN	0	0	I2CTS1	I2CTS0	0	I2CEN

- Bit 7 (I2CBF):** I2C Busy Flag bit
0: Clear to “0” under Slave mode if the received STOP signal or I2C Slave address does not match.
1: Set when I2C communicate with Master in Slave mode.
- Bit 6 (GCEN):** I2C General Call Function Enable bit
0: Disable General Call Function
1: Enable General Call Function
- Bits 5~4:** Not used, fixed to “0” all the time.

Bits 3~2 (I2CTS1~I2CTS0): I2C Transmit Clock Source Select bits (When I2CCS=0).
When operating under different Fm, these bits must be set to correct value to let SCL clock match with Standard/Fast mode.

I2CCR1 Bit 5=0, Standard mode:

I2CTS1	I2CTS0	SCL CLK	Operating Fm (MHz)
0	0	Fm/40	4
0	1	Fm/80	8
1	0	Fm/120	12
1	1	Fm/160	16

I2CCR1 Bit5=1, Fast mode:

I2CTS1	I2CTS0	SCL CLK	Operating Fm (MHz)
0	0	Fm/10	4
0	1	Fm/20	8
1	0	Fm/30	12
1	1	Fm/40	16

Bit 1: Not used, fixed to “0” all the time.

Bit 0 (I2CEN): I2C Enable Bit

0: Disable I2C mode

1: Enable I2C mode

6.3.88 Bank 1 R25: I2CSA (I2C Slave Address Register)

Bit 7	Bit 6	Bit 5	Bit 4	Bit 3	Bit 2	Bit 1	Bit 0
SA6	SA5	SA4	SA3	SA2	SA1	SA0	IRW

Bits 7~1 (SA6~SA0): When EM78F648N/F548N is used as Master device for I2C application, this is the Slave device address register.

Bit 0 (IRW): When EM78F648N is used as Master device for I2C application, this bit is Read/Write transaction control bit.

0: Write

1: Read

6.3.89 Bank 1 R26: I2CDA (I2C Device Address Register)

Bit 7	Bit 6	Bit 5	Bit 4	Bit 3	Bit 2	Bit 1	Bit 0
DA7	DA6	DA5	DA4	DA3	DA2	DA1	DA0

Bits 7~0 (DA7~DA0): When EM78F648N/F548N is used as Slave device for I2C application, this register stores the address of EM78F648N/F548N. It is used to identify the data on the I2C bus and to extract the message delivered to the EM78F648N/F548N.

6.3.90 Bank 1 R27: I2CDB (I2C Data Buffer Register)

Bit 7	Bit 6	Bit 5	Bit 4	Bit 3	Bit 2	Bit 1	Bit 0
DB7	DB6	DB5	DB4	DB3	DB2	DB1	DB0

Bits 7~0 (DB7~DB0): I2C Receive/Transmit Data Buffer.

6.3.91 Bank 1 R28: I2CA (I2C Data Buffer Register)

Bit 7	Bit 6	Bit 5	Bit 4	Bit 3	Bit 2	Bit 1	Bit 0
0	0	0	0	0	0	DA9	DA8

Bits 7~2: Not used, fixed to "0" all the time.

Bits 1~0 (DA9~DA8): Device Address high bits

6.3.92 Bank 1 R29 (Not Used)

6.3.93 Bank 1 R2A: PWMER (PWM Enable Control Register)

Bit 7	Bit 6	Bit 5	Bit 4	Bit 3	Bit 2	Bit 1	Bit 0
0	0	0	0	0	0	PWMBE	PWMAE

Bits 7~2: Not used, fixed to "0" all the time.

Bit 1 (PWMBE): PWM B Enable bit

0: PWM B is off (default value), and its related Pin P52 carries out the I/O pin function.

1: PWM B is on, and its related pin is automatically set to output.

Bit 0 (PWMAE): PWM A Enable bit

0: PWM A is OFF (default value), and its related pin carries out the I/O pin function.

1: PWM A is ON, and its related pin is automatically set to output.

6.3.94 Bank 1 R2B: TIMEN (Timer/PWM Enable Control Register)

Bit 7	Bit 6	Bit 5	Bit 4	Bit 3	Bit 2	Bit 1	Bit 0
0	0	0	0	0	0	TBEN	TAEN

Bits 7~2: Not used, fixed to "0" all the time.

Bit 1 (TBEN): Timer B enable bit

0: Timer B is off (Default)

1: Timer B is on

Bit 0 (TAEN): Timer A enable bit

0: Timer A is off (Default)

1: Timer A is on



6.3.95 Bank 1 R2C~R2E: (Not Used)

6.3.96 Bank 1 R2F: PWMACR (PWM A Control Register)

Bit 7	Bit 6	Bit 5	Bit 4	Bit 3	Bit 2	Bit 1	Bit 0
0	0	0	0	TRCBA	0	0	0

Bits 7~4: Not used, fixed to “0” all the time.

Bit 3(TRCBA): Timer A Read Control bit

0: When this bit set to “0”, the values of PRDA[9]~PRDA[0] in PRDAL and PRDxH are PWMA period data.

1: When this bit set to “1”, READ values FROM PRDA[9]~PRDA[0] in PRDAL and PRDxH are PWMA timer data.

Bits 2~0: Not used, fixed to “0” all the time.

6.3.97 Bank 1 R30: PWMBCR (PWM B Control Register)

Bit 7	Bit 6	Bit 5	Bit 4	Bit 3	Bit 2	Bit 1	Bit 0
0	0	0	0	TRCBB	0	0	0

Bits 7~4: Not used, fixed to “0” all the time.

Bit 3(TRCBB): B Read Control bit

0: When this bit set to 0, the values of PRDB[9]~PRDB[0] in PRDBL and PRDxH are PWMB period data

1: When this bit set to 1, the values of PRDB[9]~PRDB[0] in PRDBL and PRDxH are PWMB timer data

Bits 2~0: Not used, fixed to “0” all the time.

6.3.98 Bank 1 R31: (Not Used)

6.3.99 Bank 1 R32: TACR (Timer A Control Register)

Bit 7	Bit 6	Bit 5	Bit 4	Bit 3	Bit 2	Bit 1	Bit 0
0	0	0	0	0	TAP2	TAP1	TAP0

Bits 7~3: Not used, fixed to “0” all the time.

TAP2	TAP1	T1AP0	Prescaler
0	0	0	1 : 2 (Default)
0	0	1	1 : 4
0	1	0	1 : 8
0	1	1	1 : 16
1	0	0	1 : 32
1	0	1	1 : 64
1	1	0	1 : 128
1	1	1	1 : 256

6.3.100 Bank1 R33: TBCR (Timer B Control Register)

Bit 7	Bit 6	Bit 5	Bit 4	Bit 3	Bit 2	Bit 1	Bit 0
0	0	0	0	0	TBP2	TBP1	TBP0

Bits 7~3: Not used, fixed to “0” all the time.

Bits 2~0 (TBP2~TBP0): Timer B Prescaler bits

TBP2	TBP1	TBP0	Prescaler
0	0	0	1 : 2 (Default)
0	0	1	1 : 4
0	1	0	1 : 8
0	1	1	1 : 16
1	0	0	1 : 32
1	0	1	1 : 64
1	1	0	1 : 128
1	1	1	1 : 256

6.3.101 Bank 1 R34: (Not Used)

6.3.102 Bank 1 R35: TAPRDH (Timer A Period Buffer Register)

Bit 7	Bit 6	Bit 5	Bit 4	Bit 3	Bit 2	Bit 1	Bit 0
PRDA[9]	PRDA[8]	PRDB[7]	PRDB[6]	PRDB[5]	PRDB[4]	PRDB[3]	PRDB[2]

Bits 7~0 (PRDA[9]~PRDA[2]): The contents of this register is a period of Timer A.

6.3.103 Bank 1 R36: TBPRDH (Timer B Period Buffer Register)

Bit 7	Bit 6	Bit 5	Bit 4	Bit 3	Bit 2	Bit 1	Bit 0
PRDB[9]	PRDB[8]	PRDB[7]	PRDB[6]	PRDB[5]	PRDB[4]	PRDB[3]	PRDB[2]

Bits 7~0 (PRDB[9]~PRDB[2]): The contents of this register is a period of Timer B.

6.3.104 Bank 1 R37: (Not Used)

6.3.105 Bank 1 R38: TADTH (Timer A Duty Buffer Register)

Bit 7	Bit 6	Bit 5	Bit 4	Bit 3	Bit 2	Bit 1	Bit 0
DTA[9]	DTA[8]	DTA[7]	DTA[6]	DTA[5]	DTA[4]	DTA[3]	DTA[2]

Bits 7~0 (DTA[9]~DTA[2]): The contents of this register is a duty of Timer A.

6.3.106 Bank 1 R39: TBDTH (Timer B Duty Buffer Register)

Bit 7	Bit 6	Bit 5	Bit 4	Bit 3	Bit 2	Bit 1	Bit 0
DTB[9]	DTB[8]	DTB[7]	DTB[6]	DTB[5]	DTB[4]	DTB[3]	DTB[2]

Bits 7~0 (DTB[7]~DTB[0]): The contents of this register is a duty of Timer B.

6.3.107 Bank 1 R3A: (Not Used)

6.3.108 Bank 1 R3B: PRDxL (PWM A/B/C Period Buffer Low Bits Register)

Bit 7	Bit 6	Bit 5	Bit 4	Bit 3	Bit 2	Bit 1	Bit 0
0	0	0	0	PRDB[1]	PRDB[0]	PRDA[1]	PRDA[0]

Bits 7~4: Not used, fixed to “0” all the time.

Bits 3~2 (PRDB[1]~PRDB[0]): PWM B period buffer low bits

Bits 1~0 (PRDA[1]~PRDA[0]): PWM A period buffer low bits

6.3.109 Bank 1 R3C: DTxL (PWM1/2 Duty Buffer Low Bits Register)

Bit 7	Bit 6	Bit 5	Bit 4	Bit 3	Bit 2	Bit 1	Bit 0
0	0	0	0	DTB[1]	DTB[0]	DTA[1]	DTA[0]

Bits 7~4: Not used, fixed to “0” all the time.

Bits 3~2 (DTB[1]~DTB[0]): PWM B duty buffer high bits

Bits 1~0 (DTA[1]~DTA[0]): PWM A duty buffer high bits

6.3.110 Bank 1 R3D~R4F (Not Used)

6.3.111 Bank 0 R50~R7F, Bank0~1 R80~RFF

These are all 8-bit general-purpose registers.

6.4 TCC/WDT and Prescaler

Two 8-bit counters are available as prescalers for the TCC and WDT respectively. The PST0~PST2 bits of the TCCR register (Bank 0 R13) are used to determine the ratio of the prescaler of TCC. Likewise, the PSW0~PSW2 bits of the WDTCR register (Bank 0 R11) are used to determine the prescaler of WDT. The prescaler counter is cleared by the instructions each time they are written into TCC. The WDT and prescaler are cleared by the “WDTC” and “SLEP” instructions. Figure 6-11 depicts the circuit diagram of the TCC/WDT.

TCCDATA (Bank 0 R14) is an 8-bit timer/counter. The clock source of TCC can be internal clock or external signal input (edge selectable from the TCC pin). If the TCC signal source is from the internal clock, TCC will be incremented by 1 at Fc clock (without prescaler). As illustrated in the following figure, if TCC signal source is from an external clock input, TCC will be incremented by 1 at every falling edge or rising edge of the TCC pin. The TCC pin input time length (keep in High or low level) must be greater than 1/Fc. **The TCC will stop running when sleep mode occurs.**

The watchdog timer is a free running on-chip RC oscillator. The WDT will keep on running even after the oscillator driver has been turned off (i.e., in Sleep mode). During the normal operation or the Sleep mode, a WDT time-out (if enabled) will cause the device to reset. The WDT can be enabled or disabled at any time during Normal mode by software programming. Refer to WDDTE bit of Bank 0 R11 register (Section 6.3.14). Without prescaler, the WDT time-out period is approximately 18 ms¹ (one oscillator start-up timer period).

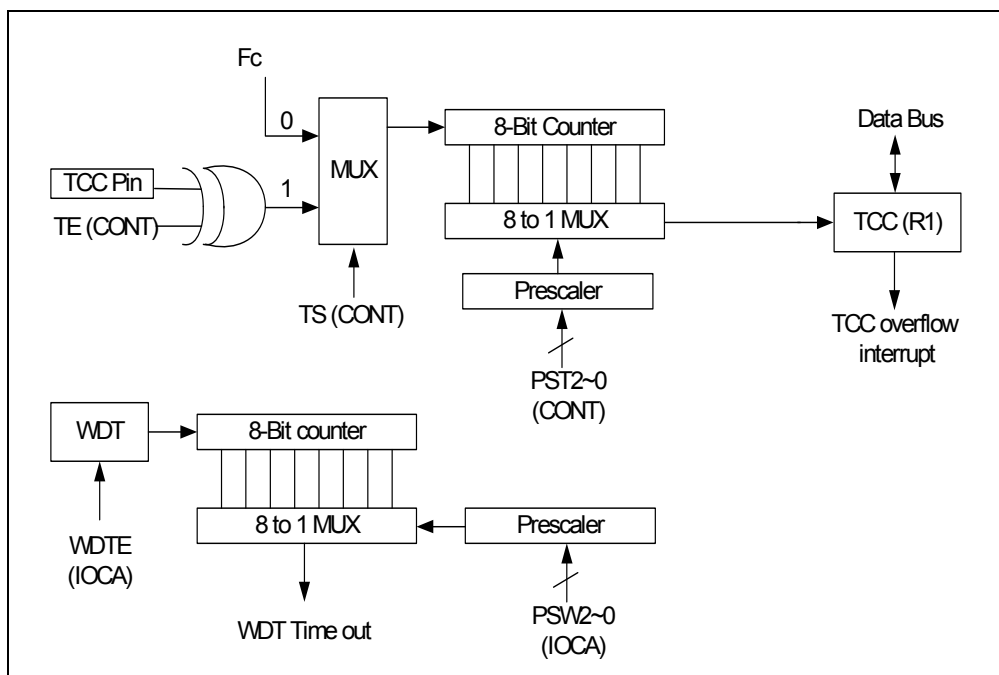

Figure 6-11 TCC and WDT Block Diagram

6.5 I/O Ports

6.5.1 I/O for EM78F644N/642/641/544/542/541N

The I/O registers, Ports 5, 6, 7, and 8, are bidirectional tri-state I/O ports. Port 6 or Port 7 can be pulled high internally by software. Moreover, Port 6 can also have an open-drain output by software. Input status change interrupt (or wake-up) function on Port 6 P50~P53, P60 ~ P63, and Port 7 pins can be pulled down by software. Each I/O pin can be defined as "input" or "output" pin by the I/O control register (IOC5 ~ IOC8).

The I/O registers and I/O control registers are both readable and writable.

¹ VDD=5V, WDT time-out period = 16.5ms ± 8%, VDD=3V, WDT time-out period = 18ms ± 8%.



6.5.2 I/O for EM78F648/548N

The I/O registers, Port 5~Port 9 are bi-directional tri-state I/O ports. All have high sink/drive setting by software. Port 5, Port 6, and Port 7 also feature Wake up function. Furthermore, Port 6 is also equipped with input status change interrupt function. Each I/O pin can be defined as "input" or "output" pin by the I/O control register (IOC5 ~ IOC9).

The I/O registers and I/O control registers are both readable and writable.

The Table below shows the usage of EM78F64xN/54xN Port 6 Input Change Wake-up/Interrupt functions:

Usage of Port 6 input status changed Wake-up/Interrupt	
<p>I. Wake-up from Port 6 Input Status Change</p> <p>a) Before SLEEP</p> <ol style="list-style-type: none"> 1. Disable WDT² (execute very carefully) 2. Read I/O Port 6 (MOV R6,R6) 3. Enable interrupt: After wake-up, if "ENI," switch to interrupt vector (006H). If "DISI," execute the next instruction. Disable interrupt: Always execute the next instruction. 4. Enable wake-up enable bit 5. Execute "SLEP" instruction <p>b) After Wake-up</p> <ol style="list-style-type: none"> 1. If "ENI" → Interrupt vector (006H) 2. If "DISI" → Next instruction 	<p>II Port 6 Input Status Change Interrupt</p> <ol style="list-style-type: none"> 1. Read I/O Port 6 (MOV R6,R6) 2. Execute "ENI" 3. Enable interrupt 4. IF Port 6 change (interrupt) → Interrupt vector (006H)

² Software disables WDT (watchdog timer) but hardware must be enabled before applying Port 6 Change Wake-up function (Code Option Register and Bit 11 (ENWDTB-) set to "1").

6.6 UART (Universal Asynchronous Receiver/Transmitter)

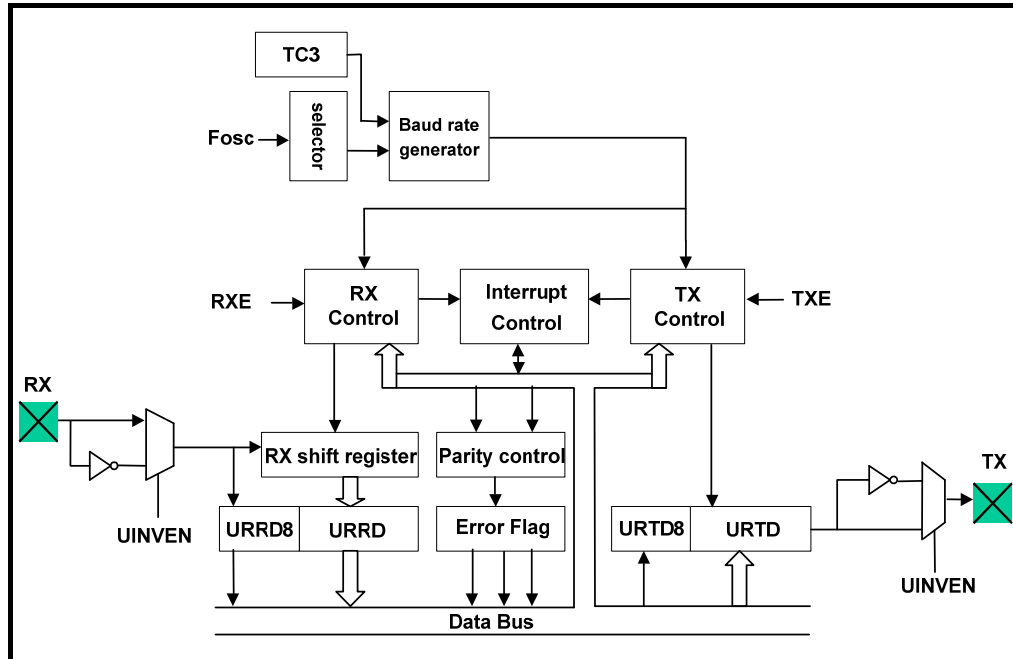

Figure 6-12a UART Function Block Diagram

In Universal Asynchronous Receiver Transmitter (UART), each transmitted or received character is individually synchronized by framing it with a start bit and stop bit.

Full duplex data transfer is possible since the UART has independent transmit and receive sections. Double buffering for both sections allows the UART to be programmed for continuous data transfer.

The figure below shows the general format of one character sent or received. The communication channel is normally held in the marked state (high). Character transmission or reception starts with a transition to the space state (low).

The first bit transmitted or received is the start bit (low). It is followed by the data bits, in which the least significant bit (LSB) comes first. The data bits are followed by the parity bit. If present, then the stop bit or bits (high) confirm the end of the frame.

In receiving, the UART synchronizes on the falling edge of the start bit. When two or three “0” are detected during three samples, it is recognized as normal start bit and the receiving operation is started.

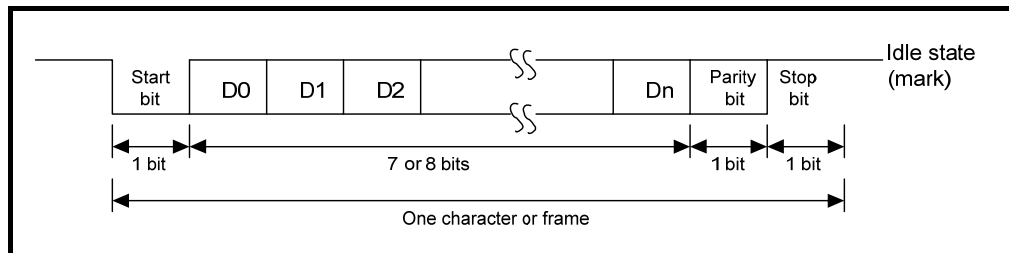

Figure 6-12b UART Data Format

6.6.1 UART Mode

Three UART modes are available. Mode 1 (7 bits data) and Mode 2 (8 bits data) allow the addition of parity bits. The parity bit addition is not available in Mode 3. Figure below shows the data format in each mode.

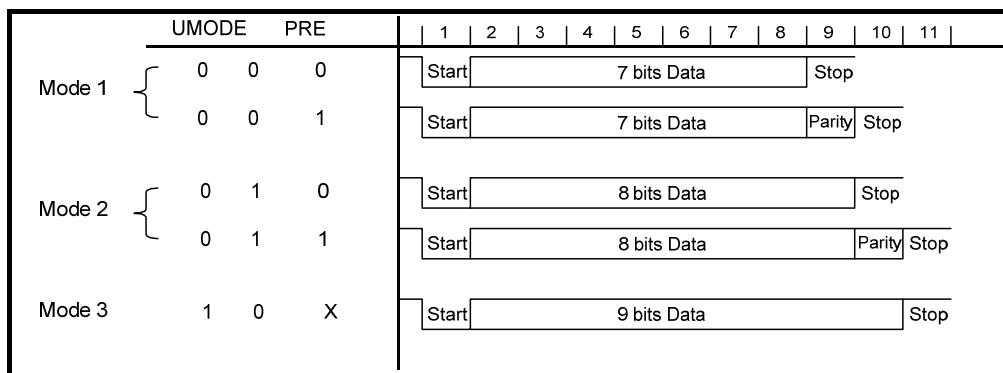

Figure 6-13 UART Modes 1, 2, &3 Data Formats

6.6.2 Transmitting

In transmitting serial data, the UART operates as follows:

1. Sets the TXE bit of the URCR1 register to enable the UART transmission function.
2. Writes data into the URTD register and the UTBE bit of the URCR1 register will be set by hardware.
3. Then start transmitting.
4. Serially transmitted data in the following order from the TX pin (see Figure 6-12b above):
 - a) Start bit: One "0" bit is output.
 - b) Transmit data: 7, 8, or 9 bits data are output from the LSB to the MSB.
 - c) Parity bit: One parity bit (odd or even selectable) is output.
 - d) Stop bit: One "1" bit (stop bit) is output.
 - e) Mark state: Output "1" continues until the start bit of the next transmitted data.

NOTE

After transmitting the Stop bit, the UART generates a TBEF interrupt (if enabled).

6.6.3 Receiving

During Receiving, the UART operates as follows:

1. Sets RXE bit of the URS register to enable the UART receiving function. The UART monitors the RX pin and synchronizes internally when it detects a Start bit.
2. Received data is shifted into the URRD register in LSB to MSB order.
3. The parity bit and the stop bit are received. After one character is received, the URBF bit of the URS register will be set to “1” to allow UART interrupt to occur.
4. The UART then makes the following checks:
 - a) Parity check: The number of ones (“1”) of the received data must match the even or odd parity setting of the EVEN bit in the URS register.
 - b) Frame check: The start bit must be “0” and the stop bit must be “1”.
 - c) Overrun check: The URBF bit of the URS register must be cleared (i.e., the URRD register should be read out) before the next received data is loaded into the URRD register.

If any of the checks failed, the UERRIF interrupt will be generated (if enabled), and an error flag is indicated in PRERR, OVERR or FMERR bit. The error flag should be cleared by software. Otherwise, UERRIF interrupt will occur when the next byte is received.

5. Read the received data from the URRD register and the URBF bit will be cleared by hardware.

6.6.4 Baud Rate Generator

The baud rate generator features a circuit that generates a clock pulse to determine the transfer speed for transmission/reception in the UART.

The BRATE 2 ~ BRATE 0 bits of the URC register determine the desired baud rate.

6.6.5 UART Timing

■ Transmission Counter Timing:

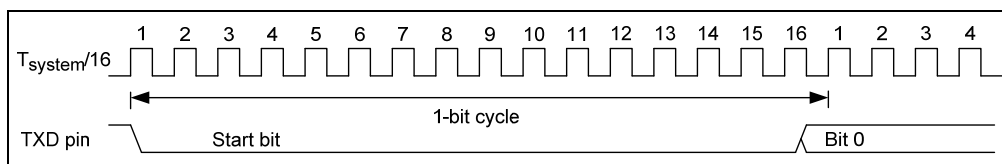

Figure 6-14a UART Transmission Counter Timing Diagram

■ Receiving Counter Timing:

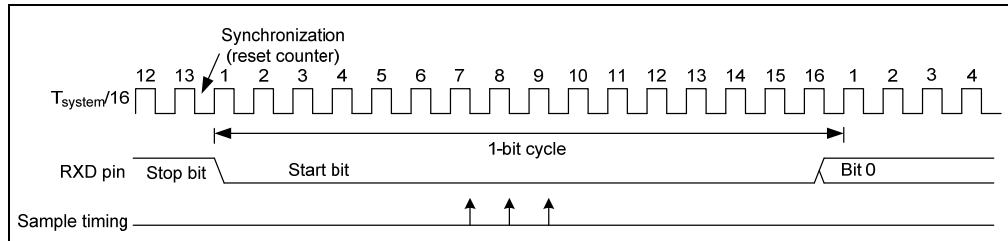

Figure 6-14b UART Receiving Counter Timing Diagram

6.7 SPI Function

6.7.1 Overview and Features

6.7.1.1 Overview

Figures 6-15a, 6-15b, and 6-16a below, illustrate how the MCUs communicate with other devices through SPI module. If the MCUs are Master controllers, they send clock through the SCK pin. A couple of 8-bit data are transmitted and received at the same time. However, if the MCUs are defined as Slaves, their SCK pins could be programmed as input pins. Data will continue to be shifted based on both the clock rate and the selected edge. User can also set the SPIS Bit 7(DORD) to decide the SPI transmission order, set the SPIS Bit 6 (TD1), Bit 5 (TD0) to determine the SDO status output delay time (see Section 6.3.30), and set SPICR Bit 3 (SDOC) to determine SDO pin status after serial data output (see Section 6.3.29).

6.7.1.2 Features

- Operation in either Master mode or Slave mode
- Three-wire or four-wire full duplex synchronous communication
- Programmable baud rates of communication
- Programming clock polarity
- Interrupt flag available for the read buffer full
- SPI transmission order
- After serial data output SDO status select
- SDO status output delay time
- SPI handshake pin
- Up to 2 MHz (maximum) bit frequency. If the system frequency (F_{osc}) operates at 8 MHz, it is recommended to choose $F_{\text{osc}}/4$ as maximum baud rate option for the SPI function.

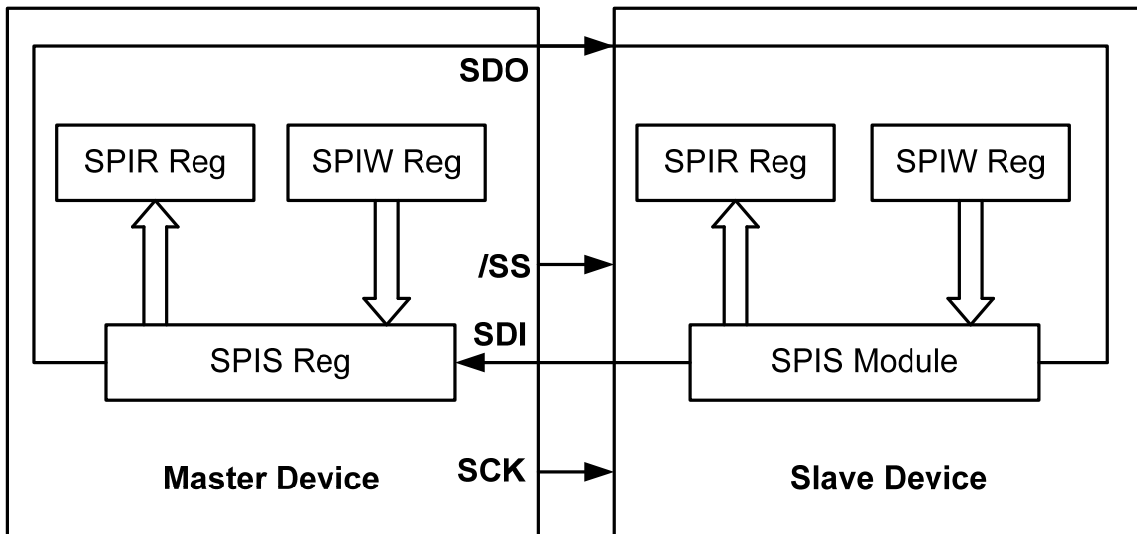

Figure 6-15a SPI Master/Slave Communication Block Diagram

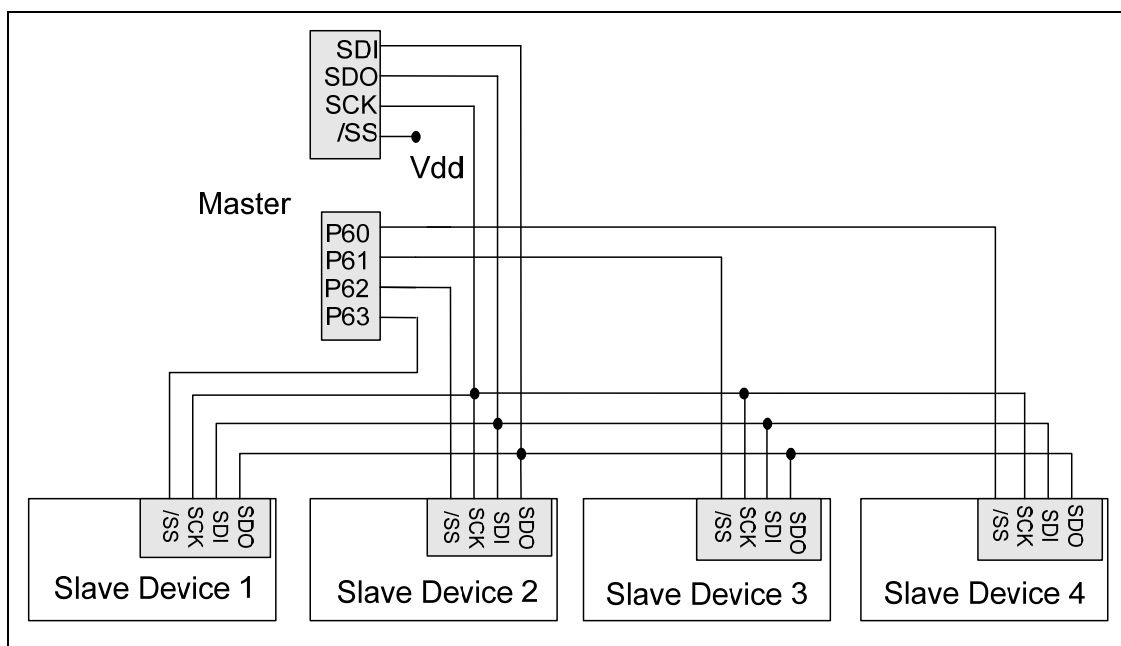

Figure 6-15b Single-Master and Multi-Slave SPI Configuration

The following describes the functions of each block and on how to carry out the SPI communication with the signals depicted in Figures 6-16a and 6-16b above.

- **SI:** Serial Data In
- **SO:** Serial Data Out
- **SCK:** Serial Clock
- **/SS:** /Slave Select (Option). This pin (/SS) may be required during a Slave mode
- **RBF:** Set by Buffer Full Detector
- **Buffer Full Detector:** Set to “1” when an 8-bit shifting is completed.
- **SSE:** Loads the data in the SPIS register, and begin to shift. The SSE bit is kept at “1” while communication is continuing and to determine if the next write attempt is available. This flag must be cleared when shifting is completed.
- **SPIS reg.:** Shifting byte in and out. The MSB is shifted first. Both the SPIR and the SPIW registers are shifted at the same time. Once data are written, SPIS starts transmission / reception. The data received will be moved to the SPIR register as the shifting of the 8-bit data is completed. The RBF (Read Buffer Full) flag and the SPIIF (SPI Interrupt) flag are then set.
- **SPIR reg.:** Read buffer. The buffer will be updated as the 8-bit shifting is completed. The data must be read before the next reception is completed. The RBF flag is cleared as the SPIR register is being read.
- **SPIW reg.:** Write buffer. The buffer will ignore any attempts to write until the 8-bit shifting is completed.
- **SBRS2~SBRS0:** Programms the clock frequency/rates and sources.
- **Clock Select:** Selects either the internal or the external clock as the shifting clock.
- **Edge Select:** Selects the appropriate clock edges by programming the CES bit

6.7.3 SPI Signal and Pin Description

The detailed functions of the four pins, SI, SO, SCK, and /SS are as follows:

- **SI:**
 - Serial Data In
 - Receive in sequential order. The Most Significant Bit (MSB) first, the Least Significant Bit (LSB) last.
 - Defined as high-impedance, if not selected.



- Program the same clock rate and clock edge to latch on both the Master and the Slave devices.
 - The received byte will update the transmitted byte.
 - The RBF will be set when the SPI operation is completed.
 - Timing is shown in Figures 6-17a and 6-17b (Section 6.7.4).
- **SO:**
- Serial Data Out
 - Transmit in sequential order. The Most Significant Bit (MSB) first, the Least Significant Bit (LSB) last
 - Program the same clock rate and clock edge to latch on both the Master and the Slave devices
 - The received byte will update the transmitted byte
 - The CES bit will reset as the SPI operation is completed
 - Timing is shown in Figures 6-17a and 6-17b (Section 6.7.4).
- **SCK:**
- Serial Clock
 - Generated by a Master device
 - Synchronize the data communication on both the SI and SO pins
 - The CES is used to select the edge to communicate.
 - The SBR0~SBR2 is used to determine the communication baud rate.
 - The CES, SBR0, SBR1, and SBR2 bits have no effect under Slave mode
 - Timing is shown in Figures 6-17a and 6-17b (Section 6.7.4).
- **/SS:**
- Slave Select; negative logic
 - Generated by a Master device to indicate the Slave(s) to receive data
 - Goes low before the first cycle of SCK appears, and remains low until the last (eighth) cycle is completed.
 - Ignores the data on the SI and SO pins while /SS is high. This is because the SO is no longer driven.
 - Timing is shown in Figures 6-17a and 6-17b (Section 6.7.4).

6.7.4 SPI Mode Timing

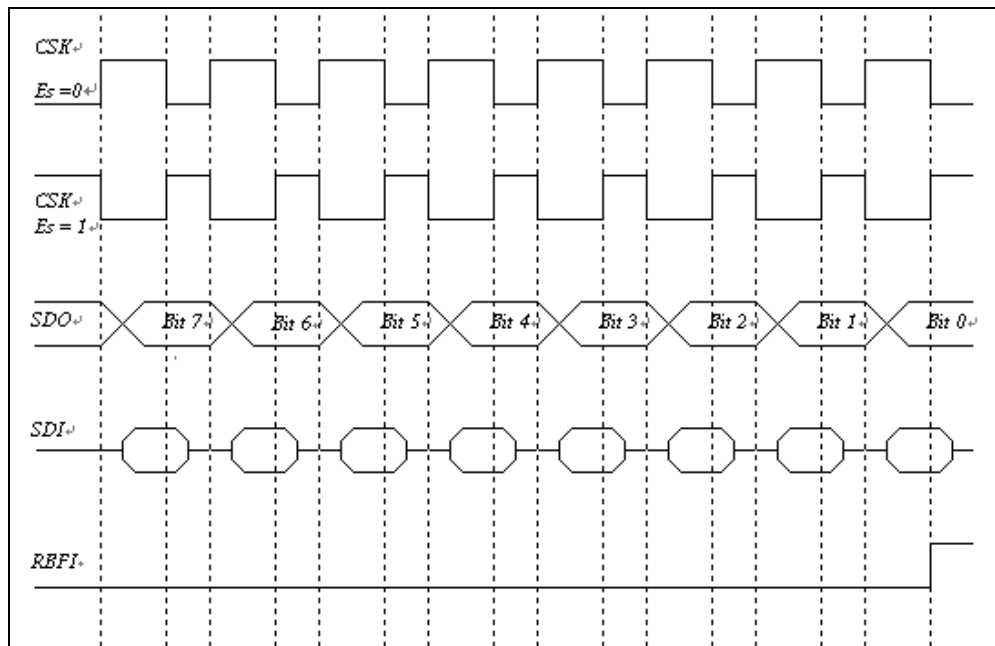

Figure 6-17a SPI Mode with /SS Disabled Timing Diagram

The SCK edge is selected by programming the CES bit. The waveform shown in the above figure (Figure 17a) is applicable regardless of whether the EM78F648N/644N/548N/544N is in Master or Slave mode with /SS disabled. However, the waveform in the figure below (Figure 17b) can only be implemented in Slave mode with /SS enabled.

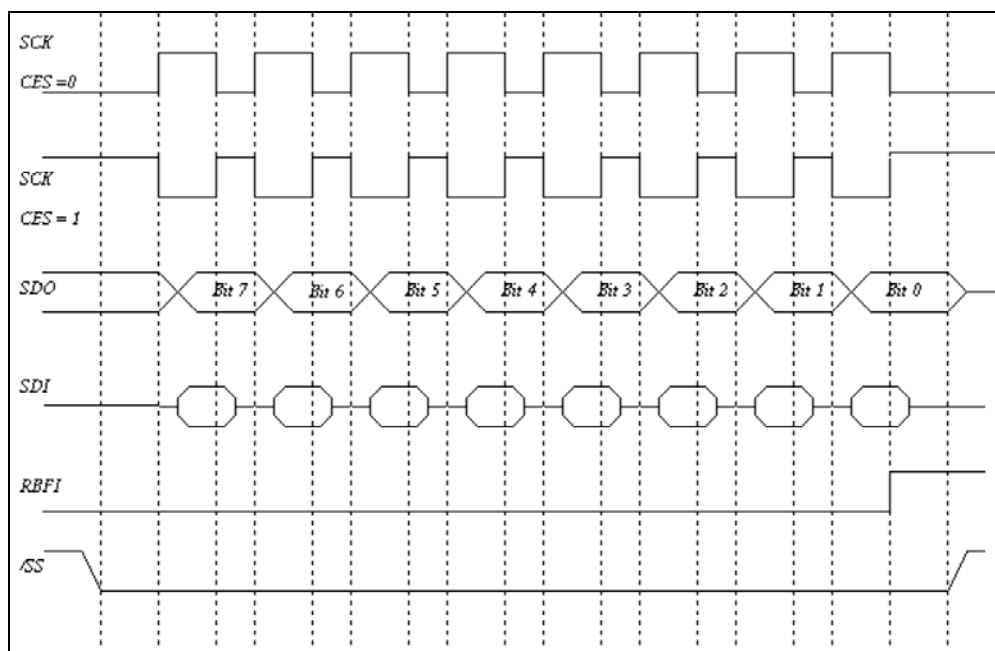

Figure 6-17b SPI Mode with /SS Enabled Timing Diagram

6.8 I2C Function

■ EM78F648N/F548N Registers for I2C Circuit

R_BANK	Address	Name	Bit 7	Bit 6	Bit 5	Bit 4	Bit 3	Bit 2	Bit 1	Bit 0
Bank 1	0X23	I2CCR1	Strobe/ Pend	IMS	ISS	STOP	SAR_ EMPTY	ACK	FULL	EMPTY
			R/W	R/W	R/W	R/W	R/W	R/W	R/W	R/W
Bank 1	0X24	I2CCR2	0	0	0	0	I2CTS1	I2CTS0	I2CCS	I2CEN
			R	R	R	R	R/W	R/W	R/W	R/W
Bank 1	0X25	I2CSA	SA6	SA5	SA4	SA3	SA2	SA1	SA0	IRW
			R/W	R/W	R/W	R/W	R/W	R/W	R/W	R/W
Bank 1	0X26	I2CDA	DA7	DA6	DA5	DA4	DA3	DA2	DA1	DA0
			R/W	R/W	R/W	R/W	R/W	R/W	R/W	R/W
Bank 1	0X27	I2CDB	DB7	DB6	DB5	DB4	DB3	DB2	DB1	DB0
			R/W	R/W	R/W	R/W	R/W	R/W	R/W	R/W
Bank 1	0X28	I2CA	0	0	0	0	0	0	DA9	DA8
			R	R	R	R	R	R	R/W	R/W
Bank 0	0x0E	ISR3	0	0	0	0	I2CSTPIF	0	I2CRIF	I2CTIF
			R	R	R	R	R/W	R	R/W	R/W
Bank 0	0x1E	IMR3	0	0	0	0	I2CSTPIE	0	I2CRIE	I2CTIE
			R	R	R	R	R/W	R	R/W	R/W

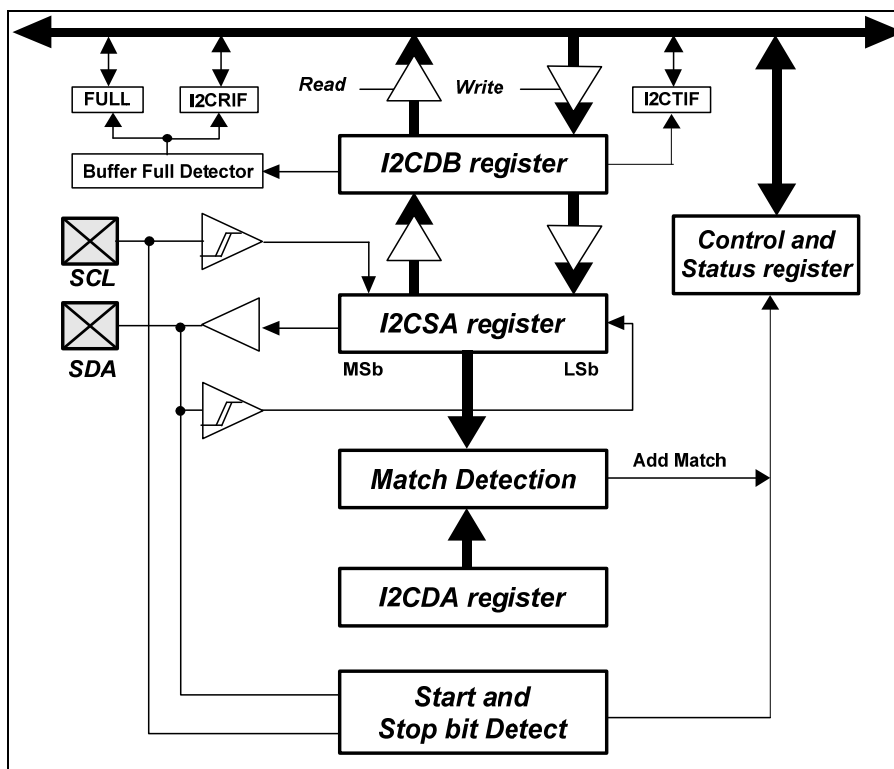

Figure 6-18a EM78F648N/F548N I2C Block Diagram

The **EM78F648N/F548N** supports bidirectional, 2-wire bus, 7-bit and 10-bit addressing as well as data transmission protocol. A device that sends data onto the bus is defined as transmitter, while a device that receives data is defined as a receiver. The bus has to be controlled by a Master device which generates the Serial Clock (SCL), controls the bus access, and generates the Start and Stop conditions. Both Master and Slave can operate as transmitter or receiver, but only the Master device can determine which mode is activated.

Both SDA and SCL are bi-directional lines, connected to a positive supply voltage via a pull-up resistor. When the bus is free, both lines are HIGH. The output stages of the devices that are connected to the bus must have an open-drain or open-collector to perform the wired-AND function. Data on the I2C-bus can be transferred at the rates of up to 100k bit/s in Standard-mode or up to 400k bit/s in the Fast-mode.

The data on the SDA line must be stable during the HIGH period of the clock. The HIGH or LOW state of the data line can only change when the clock signal on the SCL line is LOW.

Within the procedure of the I2C bus, unique situations could arise, which are defined as START (S) and STOP (P) conditions.

A HIGH to LOW transition on the SDA line while SCL is HIGH is one such unique case. This situation indicates a START condition.

A LOW to HIGH transition on the SDA line while SCL is HIGH defines a STOP condition.

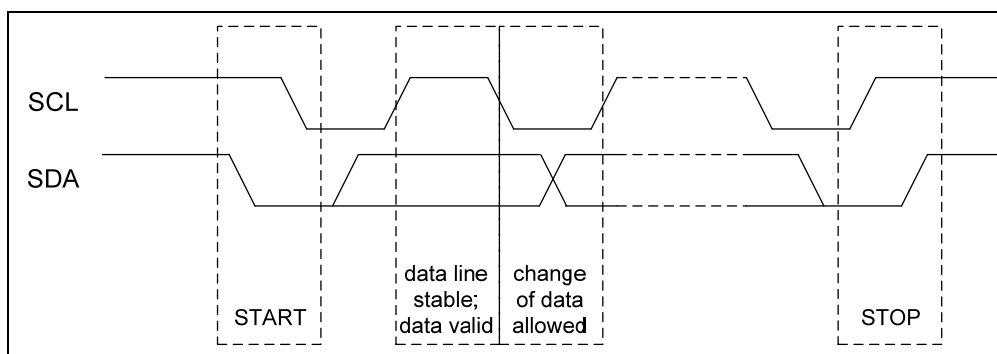

Figure 6-18b I2C Transfer Condition

6.8.1 7-Bit Slave Address

Master-transmitter transmits to Slave-receiver. The transfer direction is not changed. Master reads Slave immediately after the first byte. At the moment of the first acknowledge, the Master-transmitter becomes a Master-receiver and the Slave-receiver becomes a Slave-transmitter. This first acknowledge is still generated by the Slave. The STOP condition is generated by the Master, which has previously sent a not-acknowledge (A). The difference between Master-transmitter and Master-receiver is only with their in R/W bit. If the R/W bit is “0”, the Master device becomes a transmitter. Otherwise, the Master device turns to be a receiver (R/W bit is “1”). The Master-transmitter operation is illustrated in Figure 6-19a, and that of Master-receiver is shown in “Figure 6-19b below.

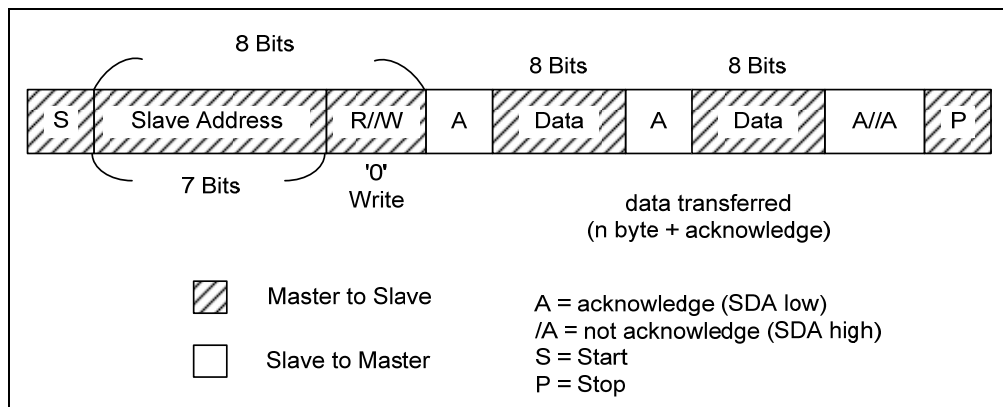

Figure 6-19a Master-Transmitter Transmits to Slave-Receiver with 7-Bit Slave Address

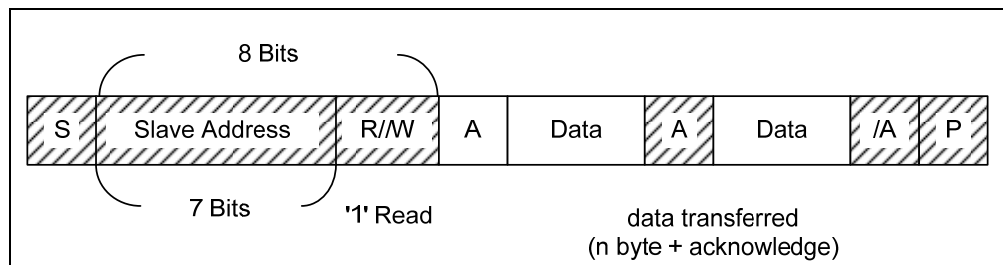

Figure 6-19b Master-Receiver Reads from Slave-Transmitter with 7-Bit Slave Address

6.8.2 10-Bit Slave Address

In 10-bit Slave Address mode, using 10-bit for addressing exploits the reserved combination 11110XX for the first 7 bits of the first byte following a START (S) or repeated START (Sr) condition. The first 7 bits of the first byte are the combination 11110XX of which the last 2 bits (XX) are the two most-significant bits of the 10-bit address. If the R/W bit were “0”, the second byte after acknowledge would be the 8 address bits of the 10-bit Slave address. Otherwise, the second byte would just be the next transmitted data from a Slave to Master device. The first bytes 11110XX are transmitted using the Slave address register (I2CSA), and the second bytes XXXXXXXX are transmitted using the data buffer (I2CDB).

The possible data transfer formats for 10-bit Slave Address Mode are explained in the following paragraphs:

6.8.2.1 Master-Transmitter Transmits to Slave-Receiver with a 10-bit Slave Address

When the Slave received the first byte after the START bit from the Master, each Slave device will compare with the 7 bits of the first byte (11110XX) with their own address and the 8th bit (R/W). If the R/W bit is “0”, the Slave will return an Acknowledge A1. It is possible that more than one Slave devices will return the Acknowledge A1. Then all Slave devices will continue to compare with the second address (XXXXXXX). If a Slave device has found a match, that particular Slave device will be the only one to return an Acknowledge A2. The matched Slave device will remain addressed by the Master until it receives a STOP condition or a repeated START condition followed by a different Slave address.

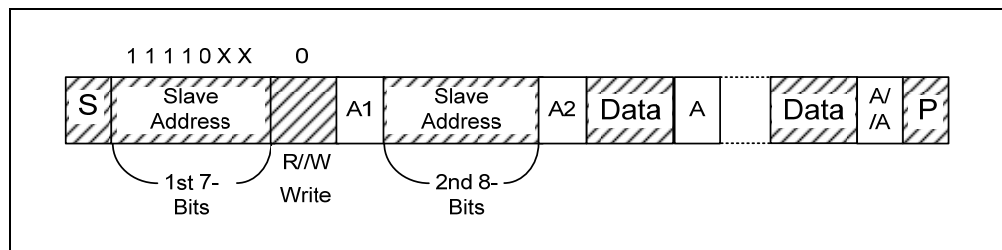

Figure 6-20a Master-Transmitter Transmits to Slave-Receiver with a 10-Bit Slave Address

6.8.2.2 Master-Receiver Reads from Slave-Transmitter with a 10-bit Slave Address

Up to, and including Acknowledge Bit A2, the procedure is the same as that described above for Master-transmitter addressing a Slave receiver. After the Acknowledge A2, a repeated START (Sr) condition takes place, followed by 7 bits Slave address (11110XX) but the 8th bit R/W is “1”. The addressed Slave device will then return an Acknowledge A3. If the repeated START (Sr) condition occurs and the 7 bits of the first byte (11110XX) are received by the Slave device, all the Slave devices will compare with their own address and test the 8th bit (R/W). However, none of the Slave devices can return an Acknowledge because R/W=1.

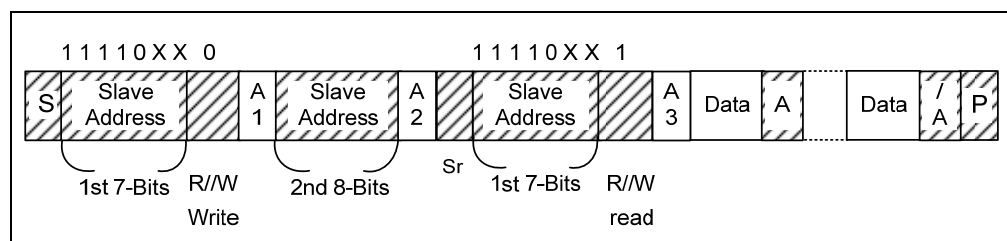

Figure 6-20b Master-Receiver Read Slave-Transmitter with a 10-Bit Slave Address

6.8.2.3 Master Transmits and Receives Data to and from the Same Slave Device with 10-Bit Addresses

The Initial operation of this data transfer format is the same as explained in Section 6.8.2.1. Then the Master device starts to transmit the data to the Slave device. When the Slave device receives an Acknowledge or Not Acknowledge that is followed by repeat START (Sr), the operation “Master-Receiver Reads from Slave-Transmitter with 10-bit Slave Address” described in the preceding Section 6.8.2.2, is then performed.

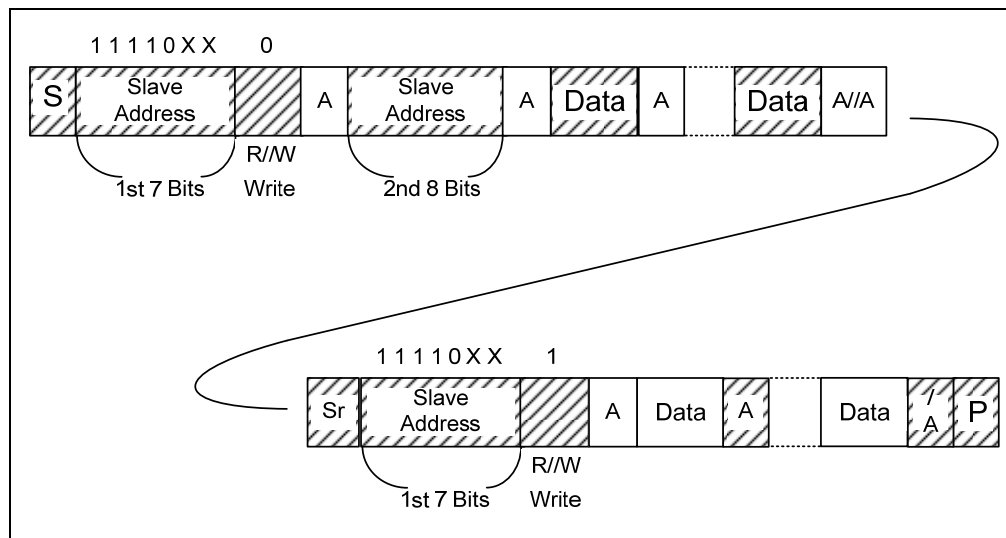

Figure 6-20c Master Addresses a Slave with 10-Bit addresses Transmits and Receives Data in the Same Slave Device.

6.8.2.4 Master Device Transmits Data to Two or More Slave Devices with 10 and 7 Bits Slave Address

For 10-bit Slave address transmittal, the initial operation of this data transmit format is the same as explained in the Section 6.8.2.1 which describes how to transmit the data to Slave device. After the Master device completed the initial transmittal, and user wants to continue transmitting data to another device, the Master needs to address each of the new Slave devices by repeating the initial operation mentioned above.

When the Master device wants to transmit data in 7-bit and 10-bit Slave address modes successively, this could be done after the START or repeat START conditions as illustrated in the following figures.

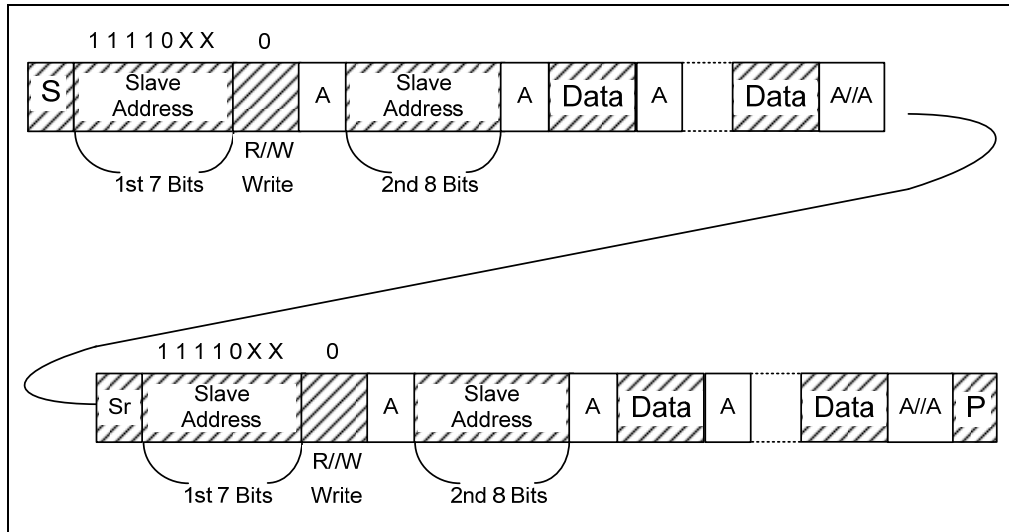

Figure 6-20d Master Transmitting to More than One Slave Devices with 10-Bit Slave Address

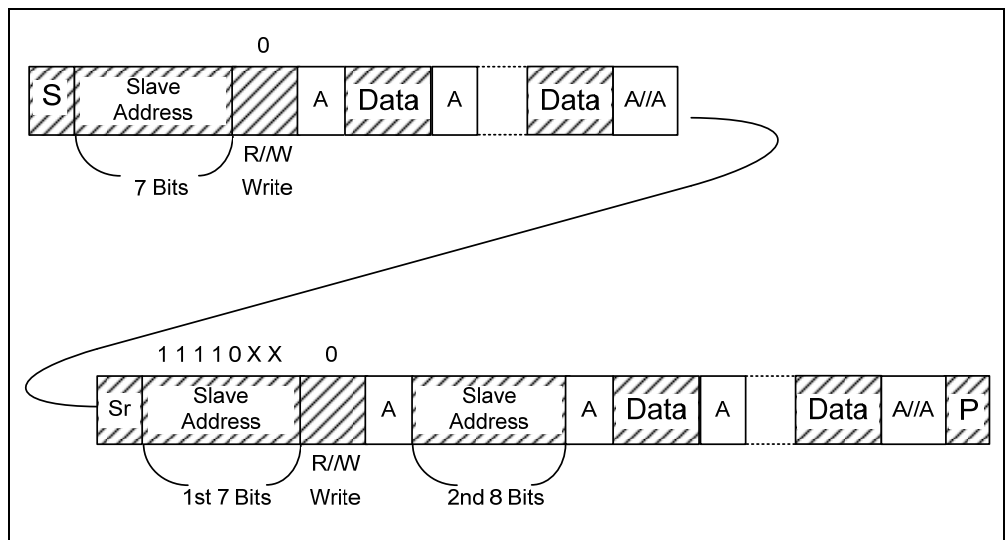

Figure 6-20e Master Successively Transmitting 7-Bit and 10-Bit Slave Addresses to Slave

6.8.3 Master Mode I2C Transmit

In transmitting serial data, the I2C operates as follows:

1. Set I2CTS1~0, I2CCS, and ISS bits to select I2C transmit clock source.
2. Set I2CEN and IMS bits to enable I2C master function.
3. Write Slave address into the I2CSA register and IRW bit to select Read or Write.
4. Set Strobe bit to start transmitting and then Check SAR_EMPTY bit.
5. Write 1st data into the I2CDB register, set Strobe bit and Check EMPTY bit.
6. Write 2nd data into the I2CDB register, set Strobe bit, STOP bit and Check EMPTY bit.

6.8.2 Slave Mode I2C Transmit

In receiving, the I2C operates as follows:

1. Set I2CTS1~0, I2CCS, and ISS bits to select I2C transmit clock source.
2. Set I2CEN and IMS bits to enable I2C Slave function.
3. Write device address into the I2CDA register.
4. Check FULL bit, read I2CDB register (address), and then clear the Pend bit.
5. Check FULL bit, read I2CDB register (1st data), and then clear the Pend bit.
6. Check FULL bit, read I2CDB register (2nd data), and then clear the Pend bit.

6.9 Dual Set of PWM (Pulse Width Modulation)

6.9.1 Overview

In PWM mode, PWMA and PWMB pins produce up to a 10-bit resolution PWM output (see Figure 6-21a below for the functional block diagram). A PWM output has a period and a duty cycle, and it keeps the output in high. The baud rate of the PWM is the inverse of the period. Figure 6-21b depicts the relationships between a period and a duty cycle.

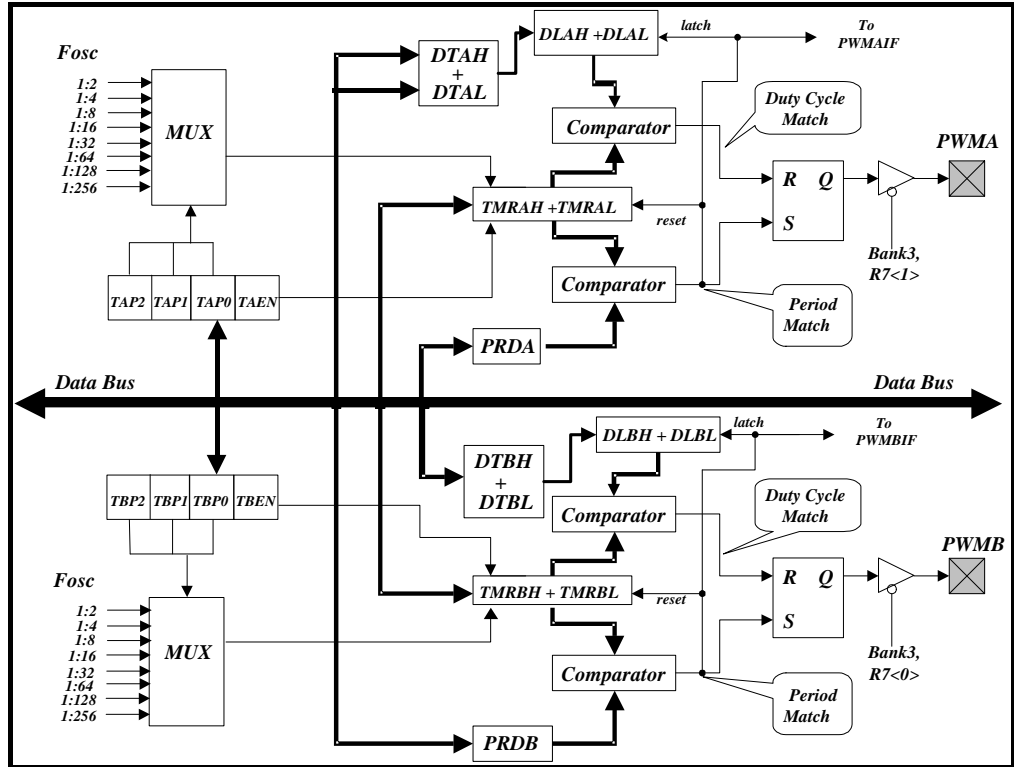

Figure 6-21a Two PWMs Functional Block Diagram

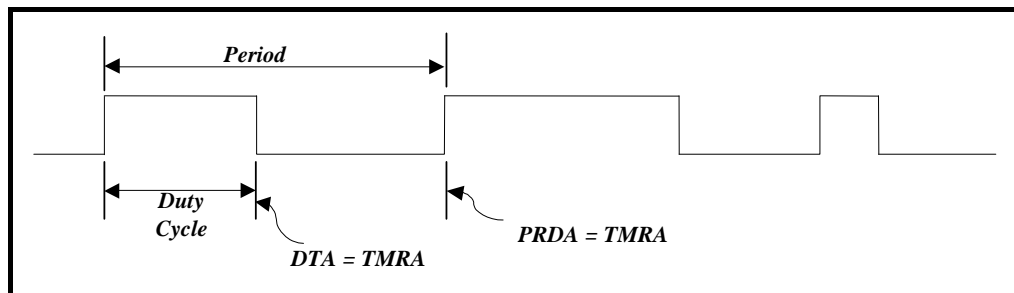

Figure 6-21b PWM Output Timing Diagram

6.9.2 Increment Timer Counter (TMRX: TMRAL/L or TMRBH/L)

TMRX are 10-bit clock counters with programmable prescalers. They are designed as baud rate clock generators for the PWM module. TMRX is Read only. When in use, they can be turned off for power saving by setting the TAEN or TBEN bits to "0".

6.9.3 PWM Period (PRDX: PRDA or PRDB)

The PWM period is defined by writing to the PRDX register. When TMRX is equal to PRDX, the following events occur on the next increment cycle:

- 1) TMRX is cleared.
- 2) The PWMX pin is set to 1.
- 3) The PWM duty cycle is latched from DTA/DTB to DLA/DLB.

NOTE

The PWM output will not be set, if the duty cycle is "0".

- (4) The PWMXIF pin is set to "1".

To calculate the PWM time period, use the following formula:

$$Period = (PRDX + 1) \times \left(\frac{1}{F_{osc}} \right) \times (TMRX \text{ prescaler value})$$

Example:

PRDX = 49; Fosc = 4 MHz, TMRX (0, 0, 0) = 1 : 2,

Then-

$$Period = (49 + 1) \times \left(\frac{1}{4M} \right) \times 2 = 25\mu s$$

6.9.4 PWM Duty Cycle (DTX: DTA or DTB)

The PWM duty cycle is defined by writing to the DTX register, and is latched from DTX to DLX while TMRX is cleared. When DLX is equal to TMRX, the PWMX pin is cleared. DTX can be loaded at any time. However, it cannot be latched into DLX until the current value of DLX is equal to TMRX.

The following formula describes how to calculate the PWM duty cycle:

$$Duty \ cycle = (DTX) \times \left(\frac{1}{F_{osc}} \right) \times (TMRX \text{ prescale value})$$

Example:

DTX = 10; Fosc = 4 MHz; TMRX (0, 0, 0) = 1 : 2,

Then-

$$Duty \ cycle = (10) \times \left(\frac{1}{4M} \right) \times 2 = 5\mu s$$

6.10 Comparator

EM78F664N/F662N/F661N/F564N/F562N/F561N has one comparator; while F648N/F548N has two comparators. Each one has two analog inputs and one output. The comparators can be utilized to Wake up the MCU from Sleep mode. The following figure illustrates the comparator circuit and operation mode.

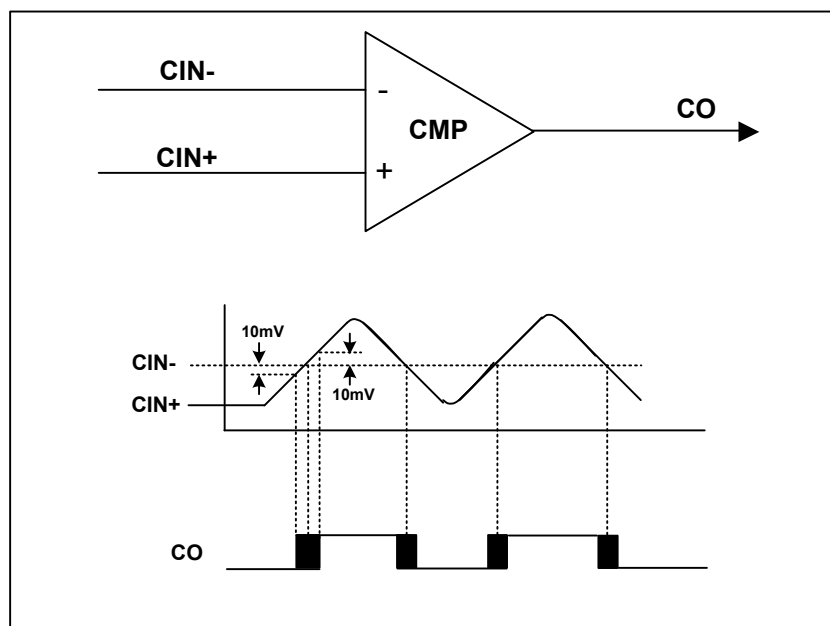

Figure 6-22 Comparator Circuit and Operation Mode

6.10.1 External Reference Signal

The analog signal that is presented at CIN- compares to the signal at CIN+, and the digital output (CO) of the comparator is adjusted accordingly.

- The reference signal must be between VSS and VDD.
- The reference voltage can be applied to either pin of the comparator.
- Threshold detector applications may use the same reference.
- The comparator can operate from the same or different reference source.

6.10.2 Internal Reference Signal

EM78F648N/F548N offers two internal voltage references which are applicable to CIN1+/CIN2+. User can utilize the voltage references in setting C1RS of R39 Bank 0 / C2RS of R3C Bank 0 and the corresponding voltage level in R43 Bank 0.

6.10.3 Comparator Outputs

For EM78F664N/F662N/F661N/F564N/F562N/F561N:

- The compared result is stored in the CPOUT2 of R7 Bit 4 of Bank 3.
- The comparator is output to CO2 (P80) by programming Bit 3, Bit 2 <COS21, COS20> of Register R7 Bank 3.

For EM78F648N/F548N:

- The compared result is stored in CP1OUT of R39 Bit 6 of Bank 0 for Comparator 1; in CP2OUT of R3C Bit 6 of Bank 0 for Comparator 2.
- By programming Bit 5, Bit 4 <CMP1COS1, CMP1COS0> of Register R39 Bank 0 and Bit 5, Bit 4 <CMP2COS1, CMP2COS0> of Register R3C Bank 0, the compared results can be output to CO1 and CO2 pins.

The following figure depicts the comparator output block diagram.

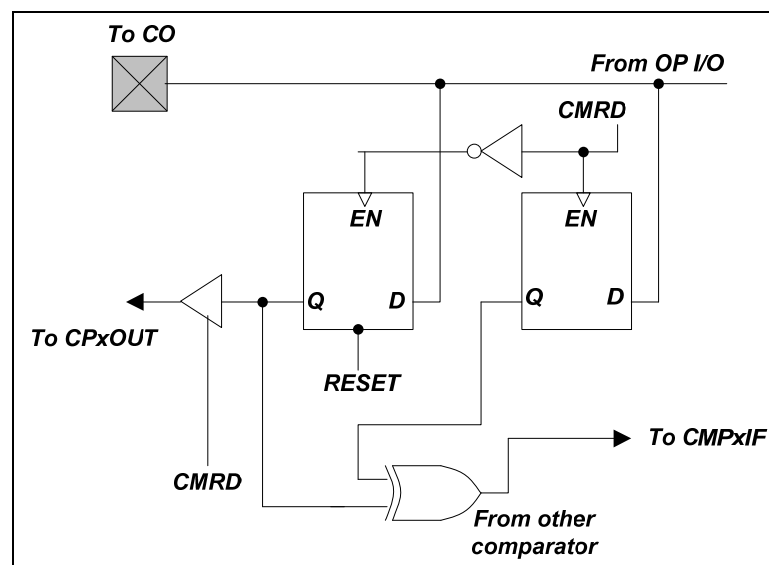

Figure 6-23 Comparator Output Block Diagram

6.10.4 Interrupt

For EM78F664N/F662N/F661N/F564N/F562N/F561N:

- CMP2IE (IOCE.7) and the “ENI” instruction execution must be enabled.
- Interrupt is executed whenever a change occurs on the output pin of the comparator.
- The actual change on the pin can be determined by reading the Bit CPOUT2, R7 Bit 4 of Bank 3.
- CMP2IF (RF.7 Bank 1) and the comparator interrupt flag, can only be cleared by software.

For EM78F648N/F548N:

- CMP1IE, CMP2IE, and the “ENI” instruction execution must be enabled.
- Interrupt occurs whenever a change occurs on the comparators output pins.
- The actual change on the pins can be determined by reading the bit CP1OUT of R39 Bit 6 of Bank 0 for Comparator 1 and the bit CP2OUT of R3C Bit 6 of Bank 0 for Comparator 2.
- CMP1IF, CMP2IF, and the comparator interrupt flags, can only be cleared by software.

6.10.5 Wake-up from Sleep Mode

- When enabled, the comparator remains active and the interrupt remains functional, even under Sleep mode.
- If a mismatch occurs, the interrupt will wake up the device from Sleep mode.
- The power consumption should be taken into consideration for the benefit of energy conservation.
- If the function is not utilized during Sleep mode, turn off the comparator before going into Sleep mode.

6.11 Reset and Wake-up**6.11.1 Reset and Wake-up for EM78F644/642/641/544/542/541N**

A Reset is initiated by one of the following events:

- 1) Power-on reset
- 2) /RESET pin input "low"
- 3) WDT time-out (if enabled)

The device is kept in a Reset condition for a period of approximately 18 ms (one oscillator start-up timer period) after a Reset is detected. Once a Reset occurs, the following functions are performed.

- The oscillator is running, or will be started.
- The Program Counter (R2) is set to all "0".
- All I/O port pins are configured as input mode (high-impedance state).
- The Watchdog timer and prescaler are cleared.
- When power is switched on, the upper three bits of R3 are cleared.
- The bits of RB, RC, RD registers are set to their previous status.
- The bits of CONT register are set to all "0".
- The bits of IOCA register are set to all "0".

- The bits of IOCB register are set to all "1".
- The bits of IOCC register are set to all "0".
- The bits of IOCD register are set to all "1".
- The bits of IOCE register are set to all "0".
- The bits of IOCF register are set to all "0".

The Sleep (power down) mode is asserted by executing the "SLEP" instruction. While entering Sleep mode, the WDT (if enabled) is cleared but keeps on running until wake-up is triggered by one of the following events (wake-up time in RC mode, the wake-up time is 10µs and in High Crystal (XTAL) mode is 800 µs):

- Event 1) External reset input on /RESET pin
- Event 2) WDT time-out (if enabled)
- Event 3) Port 6 input status changes (if enabled)
- Event 4) Comparator output status changes (if CMPWE is enabled)
- Event 5) External (P60, /INT) pin changes (if EXWE is enabled)
- Event 6) SPI receives data while SPI is acting as Slave device (if SPIWE is enabled)

The first two events will cause the IC to reset. The T and P flags of R3 can be used to determine the source of the reset (wake-up). Events 3, 4, 5, and 6 are considered as continuation of program execution and the global interrupt ("ENI" or "DISI" being executed) determines whether or not the controller branches to the interrupt vector following a wake-up. If ENI is executed before SLEP, the instruction will begin to execute from the Address 0x6, 0x15, 0x3, 0x12 after wake-up. If DISI is executed before SLEP, the execution will restart from the instruction right next to SLEP after wake-up. In RC mode, the wake-up time is 10 µs and that of High Crystal (XTAL) mode, is 800 µs.

Only one event of Events 2 to 6 can be enabled before entering into Sleep mode. That is -

- a) If WDT is enabled before SLEP, all the RA register bits are disabled. Hence, the IC can wake-up only under Events 1 or 2 conditions. Refer to the Interrupt section (Section 6.12) for further details.
- b) If Port 6 Input Status Change is used to wake-up the IC and the ICWE bit of RA register is enabled before SLEP, WDT must be disabled. Hence, the IC can wake-up only under Event 3 condition.



Under this situation, the following instructions must be executed before SLEP:

```
MOV          A, @0xxx1000b ; Select WDT prescaler and
                                ; Disable the WDT
IOW          IOCA
WDTC
MOV          R6, R6           ; Clear WDT and prescaler
ENI (or DISI)                               ; Read Port 6
                                ; Enable (or disable) global
                                ; interrupt
BC          R4, 7             ; Select Bank 0
BC          R4, 6
MOV          A, @0100xxxxb ; Enable Port 6 input change
                                ; wake-up bit
MOV          RA,A
MOV          A, @xxxxxx1xb ; Enable Port 6 input change
                                ; interrupt
IOW          IOCF
SLEP
```

- c) If Comparator 2 Output Status Change is used to wake-up the IC and the CMPWE bit of RA register is enabled before SLEP, WDT must be disabled by software. Hence, the IC can wake-up only under Event 4 condition.

Under this situation, the following instructions must be executed before SLEP:

```
BS          R4, 7             ; Select Bank 3
BS          R4, 6
MOV          A, @xxxx10xxb ; Select a comparator and P80 act
                                ; as CO pin
MOV          R7,A
MOV          A, @0xxx1000b ; Select WDT prescaler and
                                ; Disable the WDT
IOW          IOCA
WDTC
ENI (or DISI)                               ; Clear WDT and prescaler
                                ; Enable (or disable) global
                                ; interrupt
BC          R4, 7             ; Select Bank 0
BC          R4, 6
MOV          A, @1000xxxxb ; Enable comparator output status
                                ; change wake-up bit
MOV          RA,A
MOV          A, @10000000b ; Enable comparator output status
                                ; change interrupt
IOW          IOCE
SLEP
```

- d) If External (P60, /INT) pin change is used to wake-up IC and the EXWE bit of RA register is enabled before SLEP, WDT must be disabled. Hence, the IC can wake up only under Event 5 condition.

- e) When SPI is used as Slave device, IC will wake-up after receiving data, and the SPIWE bit of the RA register is enabled before SLEP. The WDT must be disabled by software. Hence, the IC can wake up only under Event 6 condition.

■ Summary of all types of Wake-up and Interrupt modes:

Wake-up Signal	Condition Signal	Sleep Mode		Idle Mode		Green Mode		Normal Mode	
		DISI	ENI	DISI	ENI	DISI	ENI	DISI	ENI
External INT	EXWE = 0, EXIE = 0	Wake-up is invalid		Wake-up is invalid		Interrupt is invalid		Interrupt is invalid	
	EXWE = 0, EXIE = 1	Wake-up is invalid		Wake-up is invalid		Next Instruction	Interrupt + Interrupt Vector	Next Instruction	Interrupt + Interrupt Vector
	EXWE = 1, EXIE = 0	Wake-up + Next Instruction		Wake-up + Next Instruction		Interrupt is invalid		Interrupt is invalid	
	EXWE = 1, EXIE = 1	Wake-up + Next Instruction	Wake-up + Interrupt Vector	Wake-up + Next Instruction	Wake-up + Interrupt Vector	Next Instruction	Interrupt + Interrupt Vector	Next Instruction	Interrupt + Interrupt Vector
Port 6 Pin Change	ICWE = 0, ICIE = 0	Wake-up is invalid		Wake-up is invalid		Interrupt is invalid		Interrupt is invalid	
	ICWE = 0, ICIE = 1	Wake-up is invalid		Wake-up is invalid.		Next Instruction	Interrupt + Interrupt Vector	Next Instruction	Interrupt + Interrupt Vector
	ICWE = 1, ICIE = 0	Wake-up + Next Instruction		Wake-up + Next Instruction		Interrupt is invalid		Interrupt is invalid	
	ICWE = 1, ICIE = 1	Wake-up + Next Instruction	Wake-up + Interrupt Vector	Wake-up + Next Instruction	Wake-up + Interrupt Vector	Next Instruction	Interrupt + Interrupt Vector	Next Instruction	Interrupt + Interrupt Vector
TCC Overflow	TCIE = 0	Wake-up is invalid		Wake-up is invalid		Interrupt is invalid		Interrupt is invalid	
	TCIE = 1	Wake-up is invalid		Wake-up + Next Instruction	Wake-up + Interrupt Vector	Next Instruction	Interrupt + Interrupt Vector	Next Instruction	Interrupt + Interrupt Vector
SPI Interrupt	SPIWE = 0, SPIIE = 0	Wake-up is invalid		Wake-up is invalid.		Interrupt is invalid.		Interrupt is invalid.	
	SPIWE = 0, SPIIE = 1	Wake-up is invalid		Wake-up is invalid		Next Instruction	Interrupt + Interrupt Vector	Next Instruction	Interrupt + Interrupt Vector
	SPIWE = 1, SPIIE = 0	Wake-up + Next Instruction*		Wake-up + Next Instruction*		Interrupt is invalid		Interrupt is invalid	
	SPIWE = 1, SPIIE = 1	Wake-up + Next Instruction*	Wake-up + Interrupt Vector*	Wake-up + Next Instruction*	Wake-up + Interrupt Vector*	Next Instruction	Interrupt + Interrupt Vector	Next Instruction	Interrupt + Interrupt Vector

* SPI must be in Slave mode

(Continuation)

Wake-up Signal	Condition Signal	Sleep Mode		Idle Mode		Green Mode		Normal Mode	
		DISI	ENI	DISI	ENI	DISI	ENI	DISI	ENI
Comparator 2 (Comparator Output Status Change)	CMP2WE=0, CMP2IE = 0	Wake-up is invalid		Wake-up is invalid		Interrupt is invalid		Interrupt is invalid	
	CMP2WE=0, CMP2IE = 1	Wake-up is invalid		Wake-up is invalid		Next Instruction	Interrupt + Interrupt Vector	Next Instruction	Interrupt + Interrupt Vector
	CMP2WE=1, CMP2IE = 0	Wake-up + Next Instruction		Wake-up + Next Instruction		Interrupt is invalid		Interrupt is invalid	
	CMP2WE=1, CMP2IE = 1	Wake-up + Next Instruction	Wake-up + Interrupt Vector	Wake-up + Next Instruction	Wake-up + Interrupt Vector	Next Instruction	Interrupt + Interrupt Vector	Next Instruction	Interrupt + Interrupt Vector
TC1 interrupt	TC1IE = 0	Wake-up is invalid		Wake-up is invalid		Interrupt is invalid		Interrupt is invalid	
	TC1IE = 1	Wake-up is invalid		Wake-up + Next Instruction	Wake-up + Interrupt Vector	Next Instruction	Interrupt + Interrupt Vector	Next Instruction	Interrupt + Interrupt Vector
UART Transmit Complete Interrupt	UTIE = 0	Wake-up is invalid		Wake-up is invalid		Interrupt is invalid		Interrupt is invalid	
	UTIE = 1	Wake-up is invalid		Wake-up is invalid		Next Instruction	Interrupt + Interrupt Vector	Next Instruction	Interrupt + Interrupt Vector
UART Receive Data Buffer Full Interrupt	URIE = 0	Wake-up is invalid		Wake-up is invalid		Interrupt is invalid		Interrupt is invalid	
	URIE = 1	Wake-up is invalid		Wake-up is invalid		Next Instruction	Interrupt + Interrupt Vector	Next Instruction	Interrupt + Interrupt Vector
UART Receive Error Interrupt	UERRIE = 0	wake-up is invalid		Wake-up is invalid		Interrupt is invalid		Interrupt is invalid	
	UERRIE = 1	Wake-up is invalid		Wake-up is invalid		Next Instruction	Interrupt + Interrupt Vector	Next Instruction	Interrupt + Interrupt Vector
TC2 Interrupt	TC2IE = 0	Wake-up is invalid		Wake-up is invalid		Interrupt is invalid		Interrupt is invalid	
	TC2IE = 1	Wake-up is invalid		Wake-up + Next Instruction	Wake-up + Interrupt Vector	Next Instruction	Interrupt + Interrupt Vector	Next Instruction	Interrupt + Interrupt Vector
TC3 Interrupt	TC3IE = 0	Wake-up is invalid		Wake-up is invalid		Interrupt is invalid		Interrupt is invalid	
	TC3IE = 1	Wake-up is invalid		Wake-up + Next Instruction	Wake-up + Interrupt Vector	Next Instruction	Interrupt + Interrupt Vector	Next Instruction	Interrupt + Interrupt Vector
PWM A/B (When TimerA/B Match PRDA/B)	PWMxIE = 0 (x = A or B)	Wake-up is invalid		Wake-up is invalid		Interrupt is invalid		Interrupt is invalid	
	PWMxIE = 1 (x = A or B)	Wake-up is invalid		Wake-up + Next Instruction	Wake-up + Interrupt Vector	Next Instruction	Interrupt + Interrupt Vector	Next Instruction	Interrupt + Interrupt Vector

NOTE

- After wake up:
1. If interrupt enabled → interrupt + next instruction
 2. If interrupt disabled → next instruction

■ Summary of the Initialized Values for Registers:

Legend: *U*: Unknown or don't care, *P*: Previous value before reset, *T*: Check table in (next) Section 6.11.3.

Address	Name	Reset Type	Bit 7	Bit 6	Bit 5	Bit 4	Bit 3	Bit 2	Bit 1	Bit 0
N/A	IOC5	Bit Name	C57	C56	C55	C54	C53	C52	C51	C50
		Power-on	1	1	1	1	1	1	1	1
		/RESET and WDT	1	1	1	1	1	1	1	1
		Wake-up from Pin Change	P	P	P	P	P	P	P	P
N/A	IOC6	Bit Name	C67	C66	C65	C64	C63	C62	C61	C60
		Power-on	1	1	1	1	1	1	1	1
		/RESET and WDT	1	1	1	1	1	1	1	1
		Wake-up from Pin Change	P	P	P	P	P	P	P	P
N/A	IOC7	Bit Name	C77	C76	C75	C74	C73	C72	-	-
		Power-on	1	1	1	1	1	1	1	1
		/RESET and WDT	1	1	1	1	1	1	1	1
		Wake-up from Pin Change	P	P	P	P	P	P	P	P
N/A	IOC8	Bit Name	-	-	-	-	*C83	C82	C81	C80
		Power-on	1	1	1	1	1	1	1	1
		/RESET and WDT	1	1	1	1	1	1	1	1
		Wake-up from Pin Change	P	P	P	P	P	P	P	P
N/A	CONT	Bit Name	INTE	INT	TS	TE	PSTE	PST2	PST1	PST0
		Power-on	0	0	0	0	0	0	0	0
		/RESET and WDT	0	0	0	0	0	0	0	0
		Wake-up from Pin Change	P	P	P	P	P	P	P	P
0x00	R0 (IAR)	Bit Name	-	-	-	-	-	-	-	-
		Power-on	U	U	U	U	U	U	U	U
		/RESET and WDT	P	P	P	P	P	P	P	P
		Wake-up from Pin Change	P	P	P	P	P	P	P	P
0x01	R1 (TCC)	Bit Name	-	-	-	SBS0	-	-	-	-
		Power-on	0	0	0	0	0	0	0	0
		/RESET and WDT	0	0	0	0	0	0	0	0
		Wake-up from Pin Change	P	P	P	P	P	P	P	P
0x02	R2 (PC)	Bit Name	-	-	-	-	-	-	-	-
		Power-on	0	0	0	0	0	0	0	0
		/RESET and WDT	0	0	0	0	0	0	0	0
		Wake-up from Pin Change	Jump to interrupt vector address or continue to execute next instruction.							

* For F644N/544N, Bit 3 is unused. Set to "0" all the time



(Continuation)

Address	Name	Reset Type	Bit 7	Bit 6	Bit 5	Bit 4	Bit 3	Bit 2	Bit 1	Bit 0
0x03	R3 (SR)	Bit Name	-	-	-	T	P	Z	DC	C
		Power-on	0	0	0	1	1	U	U	U
		/RESET and WDT	0	0	0	t	t	P	P	P
		Wake-up from Pin Change	P	P	P	t	t	P	P	P
0x04	R4 (RSR)	Bit Name	Bank 1	Bank 0	-	-	-	-	-	-
		Power-on	0	0	0	0	0	0	0	0
		/RESET and WDT	0	0	0	0	0	0	0	0
		Wake-up from Pin Change	P	P	P	P	P	P	P	P
0x05	P5 (Bank 0)	Bit Name	P57	P56	P55	P54	P53	P52	P51	P50
		Power-on	0	0	0	0	0	0	0	0
		/RESET and WDT	0	0	0	0	0	0	0	0
		Wake-up from Pin Change	P	P	P	P	P	P	P	P
0x06	P6 (Bank 0)	Bit Name	P67	P66	P65	P64	P63	P62	P61	P60
		Power-on	0	0	0	0	0	0	0	0
		/RESET and WDT	0	0	0	0	0	0	0	0
		Wake-up from Pin Change	P	P	P	P	P	P	P	P
0x07	P7 (Bank 0)	Bit Name	P77	P76	P75	P74	P73	P72	-	-
		Power-on	0	0	0	0	0	0	0	0
		/RESET and WDT	0	0	0	0	0	0	0	0
		Wake-up from Pin Change	P	P	P	P	P	P	P	P
0x08	P8 (Bank 0)	Bit Name	-	-	-	-	P83	P82	P81	P80
		Power-on	0	0	0	0	0	0	0	0
		/RESET and WDT	0	0	0	0	0	0	0	0
		Wake-up from Pin Change	P	P	P	P	P	P	P	P
0x09	R9 (Bank 0)	Bit Name	RBit7	RBit6	RBit5	RBit4	RBit3	RBit2	RBit1	RBit0
		Power-on	0	0	0	0	0	0	0	0
		/RESET and WDT	0	0	0	0	0	0	0	0
		Wake-up from Pin Change	P	P	P	P	P	P	P	P
0x0A	RA (Bank 0)	Bit Name	CMP2WE	ICWE	-	EXWE	SPIWE	-	-	-
		Power-on	0	0	0	0	0	0	0	0
		/RESET and WDT	0	0	0	0	0	0	0	0
		Wake-up from Pin Change	P	P	P	P	P	P	P	P
0x0B	RB (ECR) (Bank 0)	Bit Name	RD	WR	EEWE	EEDF	EEPC	-	-	-
		Power-on	0	0	0	0	0	0	0	0
		/RESET and WDT	P	P	P	P	P	P	P	P
		Wake-up from Pin Change	P	P	P	P	P	P	P	P

(Continuation)

Address	Name	Reset Type	Bit 7	Bit 6	Bit 5	Bit 4	Bit 3	Bit 2	Bit 1	Bit 0
0x0C	RC (Bank 0)	Bit Name	EE_A7	EE_A6	EE_A5	EE_A4	EE_A3	EE_A2	EE_A1	EE_A0
		Power-on	0	0	0	0	0	0	0	0
		/RESET and WDT	P	P	P	P	P	P	P	P
		Wake-up from Pin Change	P	P	P	P	P	P	P	P
0x0D	RD (Bank 0)	Bit Name	EE_D7	EE_D6	EE_D5	EE_D4	EE_D3	EE_D2	EE_D1	EE_D0
		Power-on	0	0	0	0	0	0	0	0
		/RESET and WDT	P	P	P	P	P	P	P	P
		Wake-up from Pin Change	P	P	P	P	P	P	P	P
0x0E	RE (Bank 0)	Bit Name	-	TIMERSC	CPUS	IDLE	-	-	-	-
		Power-on	0	1	1	1	0	0	0	0
		/RESET and WDT	0	1	1	1	0	0	0	0
		Wake-up from Pin Change	P	P	P	P	P	P	P	P
0x0F	RF (ISR) (Bank 0)	Bit Name	-	-	SPIIF	PWMBIF	PWMAIF	EXIF	ICIF	TCIF
		Power-on	0	0	0	0	0	0	0	0
		/RESET and WDT	0	0	0	0	0	0	0	0
		Wake-up from Pin Change	P	P	P	P	P	P	P	P
0x05	R5 (Bank 1)	Bit Name	TC1CAP	TC1S	TC1CK1	TC1CK0	TC1M	TC1ES	-	-
		Power-on	0	0	0	0	0	0	0	0
		/RESET and WDT	0	0	0	0	0	0	0	0
		Wake-up from Pin Change	P	P	P	P	P	P	P	P
0x06	R6 (Bank 1) TCR1DA	Bit Name	TCR1DA7	TCR1DA6	TCR1DA5	TCR1DA4	TCR1DA3	TCR1DA2	TCR1DA1	TCR1DA0
		Power-on	0	0	0	0	0	0	0	0
		/RESET and WDT	0	0	0	0	0	0	0	0
		Wake-up from Pin Change	P	P	P	P	P	P	P	P
0x07	R7 (Bank 1) TCR1DB	Bit Name	TCR1DB7	TCR1DB6	TCR1DB5	TCR1DB4	TCR1DB3	TCR1DB2	TCR1DB1	TCR1DB0
		Power-on	0	0	0	0	0	0	0	0
		/RESET and WDT	0	0	0	0	0	0	0	0
		Wake-up from Pin Change	P	P	P	P	P	P	P	P
0x08	R8 (Bank 1) TC2CR	Bit Name	RCM1	RCM0	TC2ES	TC2M	TC2S	TC2CK2	TC2CK1	TC2CK0
		Power-on	Word1<3,2>		0	0	0	0	0	0
		/RESET and WDT	Word1<3,2>		0	0	0	0	0	0
		Wake-up from Pin Change	P	P	P	P	P	P	P	P
0x09	R9 (Bank 1)	Bit Name	TC2D15	TC2D14	TC2D13	TC2D12	TC2D11	TC2D10	TC2D9	TC2D8
		Power-on	0	0	0	0	0	0	0	0
		/RESET and WDT	0	0	0	0	0	0	0	0
		Wake-up from Pin Change	P	P	P	P	P	P	P	P



(Continuation)

Address	Name	Reset Type	Bit 7	Bit 6	Bit 5	Bit 4	Bit 3	Bit 2	Bit 1	Bit 0
0x0A	RA (Bank 1)	Bit Name	TC2D7	TC2D6	TC2D5	TC2D4	TC2D3	TC2D2	TC2D1	TC2D0
		Power-on	0	0	0	0	0	0	0	0
		/RESET and WDT	0	0	0	0	0	0	0	0
		Wake-up from Pin Change	P	P	P	P	P	P	P	P
0x0B	RB (Bank 1) SPIS	Bit Name	DORD	TD1	TD0	-	OD3	OD4	-	RBF
		Power-on	0	0	0	0	0	0	0	0
		/RESET and WDT	0	0	0	0	0	0	0	0
		Wake-up from Pin Change	P	P	P	P	P	P	P	P
0x0C	RC (Bank 1) SPIC	Bit Name	CES	SPIE	SRO	SSE	SDOC	SBRS2	SBRS1	SBRS0
		Power-on	0	0	0	0	0	0	0	0
		/RESET and WDT	0	0	0	0	0	0	0	0
		Wake-up from Pin Change	P	P	P	P	P	P	P	P
0x0D	RD (Bank 1) SPIRB	Bit Name	SRB7	SRB6	SRB5	SRB4	SRB3	SRB2	SRB1	SRB0
		Power-on	U	U	U	U	U	U	U	U
		/RESET and WDT	P	P	P	P	P	P	P	P
		Wake-up from Pin Change	P	P	P	P	P	P	P	P
0x0E	RE (Bank 1) SPIWB	Bit Name	SWB7	SWB6	SWB5	SWB4	SWB3	SWB2	SWB1	SWB0
		Power-on	U	U	U	U	U	U	U	U
		/RESET and WDT	P	P	P	P	P	P	P	P
		Wake-up from Pin Change	P	P	P	P	P	P	P	P
0x0F	RF (Bank 1) ISR2	Bit Name	CMP2IF	-	TC3IF	TC2IF	TC1IF	UERRIF	RBF	TBEF
		Power-on	0	0	0	0	0	0	0	0
		/RESET and WDT	0	0	0	0	0	0	0	0
		Wake-up from Pin Change	P	P	P	P	P	P	P	P
0x0A	RA (Bank 2) URC1	Bit Name	URTD8	UMODE1	UMODE0	BRATE2	BRATE1	BRATE0	UTBE	TXE
		Power-on	U	0	0	0	0	0	0	0
		/RESET and WDT	P	P	P	P	P	P	0	0
		Wake-up from Pin Change	P	P	P	P	P	P	P	P
0x0B	RB (Bank 2) URC2	Bit Name	-	-	SBIM1	SBIM0	UINVEN	-	-	-
		Power-on	0	0	0	0	0	0	0	0
		/RESET and WDT	0	0	P	P	P	0	0	0
		Wake-up from Pin Change	P	P	P	P	P	P	P	P
0x0C	RC (Bank 2) URS	Bit Name	URRD8	EVEN	PRE	PRERR	OVERR	FMERR	URBF	RXE
		Power-on	0	0	0	0	0	0	0	0
		/RESET and WDT	P	P	P	0	0	0	0	0
		Wake-up from Pin Change	P	P	P	P	P	P	P	P



(Continuation)

Address	Name	Reset Type	Bit 7	Bit 6	Bit 5	Bit 4	Bit 3	Bit 2	Bit 1	Bit 0
0x0D	RD (Bank 2) URRD	Bit Name	URRD7	URRD6	URRD5	URRD4	URRD3	URRD2	URRD1	URRD0
		Power-on	U	U	U	U	U	U	U	U
		/RESET and WDT	P	P	P	P	P	P	P	P
		Wake-up from Pin Change	P	P	P	P	P	P	P	P
0x0E	RE (Bank 2) URTD	Bit Name	URTD7	URTD6	URTD5	URTD4	URTD3	URTD2	URTD1	URTD0
		Power-on	U	U	U	U	U	U	U	U
		/RESET and WDT	P	P	P	P	P	P	P	P
		Wake-up from Pin Change	P	P	P	P	P	P	P	P
0x0F	RF (Bank 2) PHCR1	Bit Name	/PH77	/PH76	/PH75	/PH74	/PH73	/PH72	-	-
		Power-on	1	1	1	1	1	1	1	1
		/RESET and WDT	1	1	1	1	1	1	1	1
		Wake-up from Pin Change	P	P	P	P	P	P	P	P
0x05	R5 (Bank 3) TMRCON	Bit Name	TAEN	TAP2	TAP1	TAP0	TBEN	TBP2	TBP1	TBP0
		Power-on	0	0	0	0	0	0	0	0
		/RESET and WDT	0	0	0	0	0	0	0	0
		Wake-up from Pin Change	P	P	P	P	P	P	P	P
0x06	R6 (Bank 3) TBHP	Bit Name	MLB	-	-	-	RBit11	RBit10	RBit9	RBit8
		Power-on	0	0	0	0	0	0	0	0
		/RESET and WDT	0	0	0	0	0	0	0	0
		Wake-up from Pin Change	P	P	P	P	P	P	P	P
0x07	R7 (Bank 3) CMPCON	Bit Name	-	-	-	CPOUT2	COS21	COS20	PWMAE	PWMBE
		Power-on	0	0	0	0	0	0	0	0
		/RESET and WDT	0	0	0	0	0	0	0	0
		Wake-up from Pin Change	P	P	P	P	P	P	P	P
0x08	R8 (Bank 3) PWMCON	Bit Name	PRDA[1]	PRDA[0]	DTA[1]	DTA[0]	PRDB[1]	PRDB[0]	DTB[1]	DTB[0]
		Power-on	0	0	0	0	0	0	0	0
		/RESET and WDT	0	0	0	0	0	0	0	0
		Wake-up from Pin Change	P	P	P	P	P	P	P	P
0x09	R9 (Bank 3) PRDAH	Bit Name	PRDA[9]	PRDA[8]	PRDA[7]	PRDA[6]	PRDA[5]	PRDA[4]	PRDA[3]	PRDA[2]
		Power-on	0	0	0	0	0	0	0	0
		/RESET and WDT	0	0	0	0	0	0	0	0
		Wake-up from Pin Change	P	P	P	P	P	P	P	P
0x0A	RA (Bank 3) DTAH	Bit Name	DTA[9]	DTA[8]	DTA[7]	DTA[6]	DTA[5]	DTA[4]	DTA[3]	DTA[2]
		Power-on	0	0	0	0	0	0	0	0
		/RESET and WDT	0	0	0	0	0	0	0	0
		Wake-up from Pin Change	P	P	P	P	P	P	P	P



(Continuation)

Address	Name	Reset Type	Bit 7	Bit 6	Bit 5	Bit 4	Bit 3	Bit 2	Bit 1	Bit 0
0x0B	RB (Bank 3) PRDBH	Bit Name	PRDB[9]	PRDB[8]	PRDB[7]	PRDB[6]	PRDB[5]	PRDB[4]	PRDB[3]	PRDB[2]
		Power-on	0	0	0	0	0	0	0	0
		/RESET and WDT	0	0	0	0	0	0	0	0
		Wake-up from Pin Change	P	P	P	P	P	P	P	P
0x0C	RC (Bank 3) DTBH	Bit Name	DTB[9]	DTB[8]	DTB[7]	DTB[6]	DTB[5]	DTB[4]	DTB[3]	DTB[2]
		Power-on	0	0	0	0	0	0	0	0
		/RESET and WDT	0	0	0	0	0	0	0	0
		Wake-up from Pin Change	P	P	P	P	P	P	P	P
0x0D	RD (Bank 3) TC3CR	Bit Name	TC3FF1	TC3FF0	TC3S	TC3CK2	TC3CK1	TC3CK0	TC3M1	TC3M0
		Power-on	0	0	0	0	0	0	0	0
		/RESET and WDT	0	0	0	0	0	0	0	0
		Wake-up from Pin Change	P	P	P	P	P	P	P	P
0x0E	RE (Bank 3) TC3D	Bit Name	TCR3D7	TCR3D6	TCR3D5	TCR3D4	TCR3D3	TCR3D2	TCR3D1	TCR3D0
		Power-on	0	0	0	0	0	0	0	0
		/RESET and WDT	0	0	0	0	0	0	0	0
		Wake-up from Pin Change	P	P	P	P	P	P	P	P
0x0F	RF (Bank 3) PDCR1	Bit Name	/PD77	/PD76	/PD75	/PD74	/PD73	/PD72	-	-
		Power-on	1	1	1	1	1	1	1	1
		/RESET and WDT	1	1	1	1	1	1	1	1
		Wake-Up from Pin Change	P	P	P	P	P	P	P	P
0x0A	IOCA WDTCR	Bit Name	WDTE	EIS	-	-	PSWE	PSW2	PSW1	PSW0
		Power-un	0	0	0	0	0	0	0	0
		/RESET and WDT	0	0	0	0	0	0	0	0
		Wake-up from Pin Change	P	P	P	P	P	P	P	P
0x0B	IOCB PDCR2	Bit Name	/PD63	/PD62	/PD61	/PD60	/PD53	/PD52	/PD51	/PD50
		Power-on	1	1	1	1	1	1	1	1
		/RESET and WDT	1	1	1	1	1	1	1	1
		Wake-up from Pin Change	P	P	P	P	P	P	P	P
0x0C	IOCC ODCR	Bit Name	OD67	OD66	OD65	OD64	OD63	OD62	OD61	OD60
		Power-on	0	0	0	0	0	0	0	0
		/RESET and WDT	0	0	0	0	0	0	0	0
		Wake-up from Pin Change	P	P	P	P	P	P	P	P
0x0D	IOCD PHCR2	Bit Name	/PH67	/PH66	/PH65	/PH64	/PH63	/PH62	/PH61	/PH60
		Power-on	1	1	1	1	1	1	1	1
		/RESET and WDT	1	1	1	1	1	1	1	1
		Wake-up from Pin Change	P	P	P	P	P	P	P	P

(Continuation)

Address	Name	Reset Type	Bit 7	Bit 6	Bit 5	Bit 4	Bit 3	Bit 2	Bit 1	Bit 0
0x0E	IOCE IMR2	Bit Name	CMP2IE	-	TC3IE	TC2IE	TC1IE	UERRIE	URIE	UTIE
		Power-on	0	0	0	0	0	0	0	0
		/RESET and WDT	0	0	0	0	0	0	0	0
		Wake-up from Pin Change	P	P	P	P	P	P	P	P
0x0F	IOCF IMR1	Bit Name	-	-	SPIIE	PWMBIE	PWMAIE	EXIE	ICIE	TCIE
		Power-on	0	0	0	0	0	0	0	0
		/RESET and WDT	0	0	0	0	0	0	0	0
		Wake-up from Pin Change	P	P	P	P	P	P	P	P
0x10 ~ 0x3F	R10~R3F	Bit Name	-	-	-	-	-	-	-	-
		Power-on	U	U	U	U	U	U	U	U
		/RESET and WDT	P	P	P	P	P	P	P	P
		Wake-up from Pin Change	P	P	P	P	P	P	P	P

6.11.2 Reset and Wake-up for EM78F648/548N

A Reset is initiated by one of the following events:

- 1) Power on reset
- 2) /RESET pin input "low"
- 3) WDT time-out (if enabled)

The device is kept in a Reset condition for a period of approximately 18 ms³ (one oscillator start-up timer period) after a reset is detected. If the /Reset pin goes "low" or WDT time-out is active, a Reset is generated. In RC mode the reset time is 34 clocks, while in High XTAL mode, reset time is 2 ms + 32 clocks. In Low XTAL mode, the reset time is 500 ms. Once a Reset occurs, the following functions are performed.

- The oscillator is running, or will be started.
- The Program Counter (R2) is set to all "0".
- All I/O port pins are configured as input mode (high-impedance state).
- The Watchdog timer and prescaler are cleared.
- The bits of the control register are set as indicated in the table on "Summary of the Initialized Values for Registers" as shown below.

³ Vdd = 5V, set up time period = 16.8ms ± 8%
Vdd = 3V, set up time period = 18ms ± 8%

The Sleep (power down) mode is asserted by executing the "SLEP" instruction. While entering Sleep mode, the WDT (if enabled) is cleared but keeps on running until wake-up is triggered by one of the following events (wake-up time in RC mode is 34 clocks, in High XTAL mode is 2 ms + 32 clocks, and in Low XTAL mode, is 500 ms):

- Event 1) External reset input on /RESET pin
- Event 2) WDT time-out (if enabled)
- Event 3) External (P60, /INT) pin changes (if EXWE is enabled)
- Event 4) Port 6 input status changes (if ICWE is enabled)
- Event 5) Comparator 1 or 2 output status changes (if CMP1WE/CMP2WE is enabled)
- Event 6) SPI receives data while SPI is acting as Slave device (if SPIWE is enabled)
- Event 7) Port 5/Port 7 input status changes (if corresponding control bits are enabled)

The first two cases will cause the EM78F648N/F548N to reset. The T and P flags of R3 can be used to determine the source of the reset (wake-up). Events 3, 4, 5, 6, and 7 are considered as the continuation of program execution and the global interrupt ("ENI" or "DISI" being executed) decides whether or not the controller branches to the interrupt vector following a wake-up. If ENI is executed before SLEP, the instruction will begin to execute from Address 0x3, 0x6, 0x15, 0x30 after wake-up. If DISI is executed before SLEP, the execution will restart from the instruction right next to SLEP after wake-up. All of the Sleep mode wake-up time is 150 μ s, regardless of what the status is of the oscillation mode (except for Low XTAL mode which has a wake-up time of 500 ms).

Only one of Events 2 to 7 can be enabled before entering into Sleep mode. That is -

- a) If WDT is enabled before SLEP, the EM78F648N/F548N can wake-up only by Events 1 or 2. Refer to the Interrupt section (Section 12) for further details.
- b) If External (P60, /INT) pin change is used to wake-up EM78F648N/F548N and the EXWE bit is enabled before SLEP, the WDT must be disabled. Hence, the controller can wake-up only under Event 3 condition.
- c) If Port 6 Input Status Change is used to wake-up EM78F648N/F548N and the corresponding wake-up setting is enabled before SLEP, the WDT must be disabled. Hence, the controller can wake-up only under Event 4 condition.
- d) If Comparator 1 or 2 Output Status Change is used to wake-up EM78F648N / F548N and the CMP1WE/CMP2WE bit of Bank 0 R2F register is enabled before SLEP, the WDT must be disabled by software. Hence, the controller can wake-up only under Event 5 condition.
- e) When SPI is acting as Slave device, EM78F648N/F548N will wake-up after receiving data, and the SPIWE bit of Bank 0 R2F register is enabled before SLEP, the WDT must be disabled by software. Hence, the controller can wake-up only under Event 6 condition.
- f) If Ports 6 and 7 Input Status Change is used to wake-up EM78F648N/F548N and the corresponding wake-up setting is enabled before SLEP, the WDT must be disabled. Hence, the controller can wake-up only under Event 7 condition.

■ Summary of all types of Wake-up and Interrupt modes (for EM78F648/548N only):

Wake-up Signal	Condition Signal	Sleep Mode		Idle Mode		Green Mode		Normal Mode	
		DISI	ENI	DISI	ENI	DISI	ENI	DISI	ENI
External INT	EXWE = 0, EXIE = 0	Wake-up is invalid		Wake-up is invalid		Interrupt is invalid		Interrupt is invalid	
	EXWE = 0, EXIE = 1	Wake-up is invalid		Wake-up is invalid		Next Instruction	Interrupt + Interrupt Vector	Next Instruction	Interrupt + Interrupt Vector
	EXWE = 1, EXIE = 0	Wake-up + Next Instruction		Wake-up + Next Instruction		Interrupt is invalid		Interrupt is invalid	
	EXWE = 1, EXIE = 1	Wake-up + Next Instruction	Wake-up + Interrupt Vector	Wake-up + Next Instruction	Wake-up + Interrupt Vector	Next Instruction	Interrupt + Interrupt Vector	Next Instruction	Interrupt + Interrupt Vector
Port 6 Pin Change	ICWE = 0, ICIE = 0	Wake-up is invalid		Wake-up is invalid		Interrupt is invalid		Interrupt is invalid	
	ICWE = 0, ICIE = 1	Wake-up is invalid		Wake-up is invalid		Next Instruction	Interrupt + Interrupt Vector	Next Instruction	Interrupt + Interrupt Vector
	ICWE = 1, ICIE = 0	Wake-up + Next Instruction		Wake-up + Next Instruction		Interrupt is invalid		Interrupt is invalid	
	ICWE = 1, ICIE = 1	Wake-up + Next Instruction	Wake-up + Interrupt Vector	Wake-up + Next Instruction	Wake-up + Interrupt Vector	Next Instruction	Interrupt + Interrupt Vector	Next Instruction	Interrupt + Interrupt Vector
TCC Overflow	TCIE = 0	Wake-up is invalid		Wake-up is invalid		Interrupt is invalid		Interrupt is invalid	
	TCIE = 1	Wake-up is invalid		Wake-up + Next Instruction	Wake-up + Interrupt Vector	Next Instruction	Interrupt + Interrupt Vector	Next Instruction	Interrupt + Interrupt Vector
SPI Interrupt	SPIWE = 0, SPIIE = 0	Wake-up is invalid		Wake-up is invalid		Interrupt is invalid		Interrupt is invalid.	
	SPIWE = 0, SPIIE = 1	Wake-up is invalid		Wake-up is invalid		Next Instruction	Interrupt + Interrupt Vector	Next Instruction	Interrupt + Interrupt Vector
	SPIWE = 1, SPIIE = 0	Wake-up + Next Instruction*		Wake-up + Next Instruction*		Interrupt is invalid		Interrupt is invalid	
	SPIWE = 1, SPIIE = 1	Wake-up + Next Instruction*	Wake-up + Interrupt Vector*	Wake-up + Next Instruction*	Wake-up + Interrupt Vector*	Next Instruction	Interrupt + Interrupt Vector	Next Instruction	Interrupt + Interrupt Vector

* SPI must be in Slave mode

(Continuation)

Wake-up Signal	Condition Signal	Sleep Mode		Idle Mode		Green Mode		Normal Mode	
		DISI	ENI	DISI	ENI	DISI	ENI	DISI	ENI
Comparator x (Comparator Output Status Change) x = 1, 2	CMPxWE=0 CMPxIE = 0	Wake-up is invalid		Wake-up is invalid		Interrupt is invalid		Interrupt is invalid	
	CMPxWE=0 CMPxIE = 1	Wake-up is invalid		Wake-up is invalid		Next Instruction	Interrupt + Interrupt Vector	Next Instruction	Interrupt + Interrupt Vector
	CMPxWE=1 CMPxIE = 0	Wake-up + Next Instruction		Wake-up + Next Instruction		Interrupt is invalid		Interrupt is invalid	
	CMPxWE=1 CMPxIE = 1	Wake-up + Next Instruction	Wake-up + Interrupt Vector	Wake-up + Next Instruction	Wake-up + Interrupt Vector	Next Instruction	Interrupt + Interrupt Vector	Next Instruction	Interrupt + Interrupt Vector
TC1 interrupt	TC1IE = 0	Wake-up is invalid		Wake-up is invalid		Interrupt is invalid		Interrupt is invalid	
	TC1IE = 1	Wake-up is invalid		Wake-up + Next Instruction	Wake-up + Interrupt Vector	Next Instruction	Interrupt + Interrupt Vector	Next Instruction	Interrupt + Interrupt Vector
UART Transmit Complete Interrupt	UTIE = 0	Wake-up is invalid		Wake-up is invalid		Interrupt is invalid		Interrupt is invalid	
	UTIE = 1	Wake-up is invalid		Wake-up is invalid		Next Instruction	Interrupt + Interrupt Vector	Next Instruction	Interrupt + Interrupt Vector
UART Receive Data Buffer Full Interrupt	URIE = 0	Wake-up is invalid		Wake-up is invalid		Interrupt is invalid		Interrupt is invalid	
	URIE = 1	Wake-up is invalid		Wake-up is invalid		Next Instruction	Interrupt + Interrupt Vector	Next Instruction	Interrupt + Interrupt Vector
UART Receive Error Interrupt	UERRIE = 0	Wake-up is invalid		Wake-up is invalid		Interrupt is invalid		Interrupt is invalid	
	UERRIE = 1	Wake-up is invalid		Wake-up is invalid		Next Instruction	Interrupt + Interrupt Vector	Next Instruction	Interrupt + Interrupt Vector
TC2 Interrupt	TC2IE = 0	Wake-up is invalid		Wake-up is invalid		Interrupt is invalid		Interrupt is invalid	
	TC2IE = 1	Wake-up is invalid		Wake-up + Next Instruction	Wake-up + Interrupt Vector	Next Instruction	Interrupt + Interrupt Vector	Next Instruction	Interrupt + Interrupt Vector

(Continuation)

Wake-up Signal	Condition Signal	Sleep Mode		Idle Mode		Green Mode		Normal Mode	
		DISI	ENI	DISI	ENI	DISI	ENI	DISI	ENI
LVD	LVDWE = 0, CMPxIE = 0	Wake-up is invalid		Wake-up is invalid		Interrupt is invalid		Interrupt is invalid	
	LVDWE = 0, LVDIE = 1	Wake-up is invalid		Wake-up is invalid		Next Instruction	Interrupt + Interrupt Vector	Next Instruction	Interrupt + Interrupt Vector
	LVDWE = 1, LVDIE = 0	Wake-up + Next Instruction		Wake-up + Next Instruction		Interrupt is invalid		Interrupt is invalid	
	LVDWE = 1, LVDIE = 1	Wake-up + Next Instruction	Wake-up + Interrupt Vector	Wake-up + Next Instruction	Wake-up + Interrupt Vector	Next Instruction	Interrupt + Interrupt Vector	Next Instruction	Interrupt + Interrupt Vector
TC3 Interrupt	TC3IE = 0	Wake-up is invalid		Wake-up is invalid		Interrupt is invalid		Interrupt is invalid	
	TC3IE = 1	Wake-up is invalid		Wake-up + Next Instruction	Wake-up + Interrupt Vector	Next Instruction	Interrupt + Interrupt Vector	Next Instruction	Interrupt + Interrupt Vector
PWM A/B (When Timer A/B Match PRDA/B)	PWMxIE = 0 (x = A or B)	Wake-up is invalid		Wake-up is invalid		Interrupt is invalid		Interrupt is invalid	
	PWMxIE = 1 (x = A or B)	Wake-up is invalid		Wake-up + Next Instruction	Wake-up + Interrupt Vector	Next Instruction	Interrupt + Interrupt Vector	Next Instruction	Interrupt + Interrupt Vector
I2C TX Interrupt	I2CTIE = 0	Wake-up is invalid		Wake-up is invalid		Interrupt is invalid		Interrupt is invalid	
	I2CTIE = 1	Wake-up is invalid		Wake-up is invalid		Next Instruction	Interrupt + Interrupt Vector	Next Instruction	Interrupt + Interrupt Vector
I2C RX Interrupt	I2CRIE = 0	Wake-up if received correct address		Wake-up if received correct address		Interrupt is invalid		Interrupt is invalid	
	I2CRIE = 1	Wake-up if received correct address		Wake-up if received correct address		Next Instruction	Interrupt + Interrupt Vector	Next Instruction	Interrupt + Interrupt Vector
I2C STOP Interrupt	I2CSTPIE=0	Wake-up is invalid		Wake-up is invalid		Interrupt is invalid		Interrupt is invalid	
	I2CSTPIE=1	Wake-up is invalid		Wake-up is invalid		Next Instruction	Interrupt + Interrupt Vector	Next Instruction	Interrupt + Interrupt Vector

NOTE

After wake up:

1. If interrupt is enabled → interrupt + next instruction
2. If interrupt is disabled → next instruction



■ Summary of the Initialized Values for Registers (for EM78F648/548N only):

Legend: *U*: Unknown or don't care, *P*: Previous value before reset, *T*: Check table in (next) Section 6.11.3.

Address	Bank, Name	Reset Type	Bit 7	Bit 6	Bit 5	Bit 4	Bit 3	Bit 2	Bit 1	Bit 0
0x00	R0 (IAR)	Bit Name	-	-	-	-	-	-	-	-
		Power-on	U	U	U	U	U	U	U	U
		/RESET and WDT	P	P	P	P	P	P	P	P
		Wake-up from Pin Change	P	P	P	P	P	P	P	P
0x01	R1 (BSR)	Bit Name	0	0	0	SBS0	0	0	0	GBS0
		Power-on	0	0	0	U	0	0	0	U
		/RESET and WDT	0	0	0	0	0	0	0	0
		Wake-up from Pin Change	0	0	0	P	0	0	0	P
0x02	R2 (PC)	Bit Name	-	-	-	-	-	-	-	-
		Power-on	0	0	0	0	0	0	0	0
		/RESET and WDT	0	0	0	0	0	0	0	0
		Wake-up from Pin Change	P	P	P	P	P	P	P	P
0x03	R3 (SR)	Bit Name	0	0	0	T	P	Z	DC	C
		Power-on	0	0	0	1	1	U	U	U
		/RESET and WDT	0	0	0	t	t	P	P	P
		Wake-up from Pin Change	0	0	0	t	t	P	P	P
0x04	R4 (RSR)	Bit Name	RSR7	RSR6	RSR5	RSR4	RSR3	RSR2	RSR1	RSR0
		Power-on	U	U	U	U	U	U	U	U
		/RESET and WDT	P	P	P	P	P	P	P	P
		Wake-up from Pin Change	P	P	P	P	P	P	P	P
0x05	Bank 0, R5 (Port 5)	Bit Name	P57	P56	P55	P54	P53	P52	P51	P50
		Power-on	0	0	0	0	0	0	0	0
		/RESET and WDT	0	0	0	0	0	0	0	0
		Wake-up from Pin Change	P	P	P	P	P	P	P	P
0x06	Bank 0, R6 (Port 6)	Bit Name	P67	P66	P65	P64	P63	P62	P61	P60
		Power-on	0	0	0	0	0	0	0	0
		/RESET and WDT	0	0	0	0	0	0	0	0
		Wake-up from Pin Change	P	P	P	P	P	P	P	P
0x07	Bank 0, R7 (Port 7)	Bit Name	P77	P76	P75	P74	P73	P72	P71	P70
		Power-on	0	0	0	0	0	0	0	0
		/RESET and WDT	0	0	0	0	0	0	0	0
		Wake-up from Pin Change	P	P	P	P	P	P	P	P
0x08	Bank 0, R8 (Port 8)	Bit Name	P87	P86	P85	P84	P83	P82	P81	P80
		Power-on	0	0	0	0	0	0	0	0
		/RESET and WDT	0	0	0	0	0	0	0	0
		Wake-up from Pin Change	P	P	P	P	P	P	P	P

(Continuation)

Address	Bank Name	Reset Type	Bit 7	Bit 6	Bit 5	Bit 4	Bit 3	Bit 2	Bit 1	Bit 0
0x09	Bank 0, R9 (Port 9)	Bit Name	P97	P96	P95	P94	P93	P92	P91	P90
		Power-on	0	0	0	0	0	0	0	0
		/RESET and WDT	0	0	0	0	0	0	0	0
		Wake-up from Pin Change	P	P	P	P	P	P	P	P
0x0B	Bank 0, RB (OMCR)	Bit Name	CPUS	IDLE	TC1SS	TC2SS	TC3SS	TASS	TBSS	0
		Power-on	1	1	0	0	0	0	0	0
		/RESET and WDT	1	1	0	0	0	0	0	0
		Wake-up from Pin Change	P	P	P	P	P	P	P	P
0x0C	Bank 0, RC (ISR1)	Bit Name	LVDIF	ADIF	SPIF	PWMBIF	PWMAIF	EXIF	ICIF	TCIF
		Power-on	0	0	0	0	0	0	0	0
		/RESET and WDT	0	0	0	0	0	0	0	0
		Wake-up from Pin Change	P	P	P	P	P	P	P	P
0x0D	Bank 0, RD (ISR2)	Bit Name	CMP2IF	CMP1IF	TC3IF	TC2IF	TC1IF	UERRIF	RBFIF	TBEF
		Power-on	0	0	0	0	0	0	0	0
		/RESET and WDT	0	0	0	0	0	0	0	0
		Wake-up from Pin Change	P	P	P	P	P	P	P	P
0x0E	Bank 0, RE (ISR3)	Bit Name	0	0	0	0	I2CDTPIF	0	I2CRIF	I2CTIF
		Power-on	0	0	0	0	0	0	0	0
		/RESET and WDT	0	0	0	0	0	0	0	0
		Wake-up from Pin Change	P	P	P	P	P	P	P	P
0x10	Bank 0, R10 EIESCR	Bit Name	0	0	0	0	0	0	0	EIES
		Power-on	0	0	0	0	0	0	0	0
		/RESET and WDT	0	0	0	0	0	0	0	0
		Wake-up from Pin Change	0	0	0	0	0	0	0	P
0x11	Bank 0, R11 WDTCR	Bit Name	WDTE	EIS	INT	0	PSWE	PSW2	PSW1	PSW0
		Power-on	0	0	0	0	0	0	0	0
		/RESET and WDT	0	0	0	0	0	0	0	0
		Wake-up from Pin Change	P	P	P	0	P	P	P	P
0x12	Bank 0, R12 LVDRCR	Bit Name	0	0	0	0	LVDEN	/LVD	LVD1	LVD0
		Power-on	0	0	0	0	0	R	0	0
		/RESET and WDT	0	0	0	0	0	R	0	0
		Wake-up from Pin Change	0	0	0	0	P	R	P	P
0x13	Bank 0, R13 TCCCR	Bit Name	0	TCCS	TS	TE	PSTE	PST2	PST1	PST0
		Power-on	0	0	0	0	0	0	0	0
		/RESET and WDT	0	0	0	0	0	0	0	0
		Wake-up from Pin Change	0	P	P	P	P	P	P	P



(Continuation)

Address	Bank Name	Reset Type	Bit 7	Bit 6	Bit 5	Bit 4	Bit 3	Bit 2	Bit 1	Bit 0
0X14	Bank 0, R14 TCCDATA	Bit Name	-	-	-	-	-	-	-	-
		Power-on	0	0	0	0	0	0	0	0
		/RESET and WDT	0	0	0	0	0	0	0	0
		Wake-up from Pin Change	P	P	P	P	P	P	P	P
0X15	Bank 0, R15 IOCR5	Bit Name	IOC57	IOC56	IOC55	IOC54	IOC53	IOC52	IOC51	IOC50
		Power-on	1	1	1	1	1	1	1	1
		/RESET and WDT	1	1	1	1	1	1	1	1
		Wake-up from Pin Change	P	P	P	P	P	P	P	P
0X16	Bank 0, R16 IOCR6	Bit Name	IOC67	IOC66	IOC65	IOC64	IOC63	IOC62	IOC61	IOC60
		Power-on	1	1	1	1	1	1	1	1
		/RESET and WDT	1	1	1	1	1	1	1	1
		Wake-up from Pin Change	P	P	P	P	P	P	P	P
0X17	Bank 0, R17 IOCR7	Bit Name	IOC77	IOC76	IOC75	IOC74	IOC73	IOC72	IOC71	IOC70
		Power-on	1	1	1	1	1	1	1	1
		/RESET and WDT	1	1	1	1	1	1	1	1
		Wake-up from Pin Change	P	P	P	P	P	P	P	P
0X18	Bank 0, R18 IOCR8	Bit Name	IOC87	IOC86	IOC85	IOC84	IOC83	IOC82	IOC81	IOC80
		Power-On	1	1	1	1	1	1	1	1
		/RESET and WDT	1	1	1	1	1	1	1	1
		Wake-Up from Pin Change	P	P	P	P	P	P	P	P
0X19	Bank 0, R19 IOCR9	Bit Name	IOC97	IOC96	IOC95	IOC94	IOC93	IOC92	IOC91	IOC90
		Power-on	1	1	1	1	1	1	1	1
		/RESET and WDT	1	1	1	1	1	1	1	1
		Wake-up from Pin Change	P	P	P	P	P	P	P	P
0X1C	Bank 0, R1C IMR1	Bit Name	LVDIE	0	SPIE	PWMBIE	PWMAIE	EXIE	ICIE	TCIE
		Power-on	0	0	0	0	0	0	0	0
		/RESET and WDT	0	0	0	0	0	0	0	0
		Wake-up from Pin Change	P	P	P	P	P	P	P	P
0X1D	Bank 0, R1D IMR2	Bit Name	CMP2IE	CMP1IE	TC3IE	TC2IE	TC1IE	UERRIE	URIE	UTIE
		Power-on	0	0	0	0	0	0	0	0
		/RESET and WDT	0	0	0	0	0	0	0	0
		Wake-up from Pin Change	P	P	P	P	P	P	P	P
0X1E	Bank 0, R1E IMR3	Bit Name	0	0	0	0	I2CSTPIE	0	I2CRIE	I2CTIE
		Power-on	0	0	0	0	0	0	0	0
		/RESET and WDT	0	0	0	0	0	0	0	0
		Wake-up from Pin Change	P	P	P	P	P	P	P	P



(Continuation)

Address	Bank Name	Reset Type	Bit 7	Bit 6	Bit 5	Bit 4	Bit 3	Bit 2	Bit 1	Bit 0
0X20	Bank 0, R20 P5WUCR	Bit Name	WU_P57	WU_P56	WU_P55	WU_P54	WU_P53	WU_P52	WU_P51	WU_P50
		Power-on	0	0	0	0	0	0	0	0
		/RESET and WDT	0	0	0	0	0	0	0	0
		Wake-up from Pin Change	P	P	P	P	P	P	P	P
0X21	Bank 0, R21 P5WUECR	Bit Name	WUE_P57	WUE_P56	WUE_P55	WUE_P54	WUE_P53	WUE_P52	WUE_P51	WUE_P50
		Power-on	0	0	0	0	0	0	0	0
		/RESET and WDT	0	0	0	0	0	0	0	0
		Wake-up from Pin Change	P	P	P	P	P	P	P	P
0X22	Bank 0, R22 P7WUCR	Bit Name	WU_P77	WU_P76	WU_P75	WU_P74	WU_P73	WU_P72	WU_P71	WU_P70
		Power-on	0	0	0	0	0	0	0	0
		/RESET and WDT	0	0	0	0	0	0	0	0
		Wake-up from Pin Change	P	P	P	P	P	P	P	P
0X23	Bank 0, R23 P7WUECR	Bit Name	WUE_P77	WUE_P76	WUE_P75	WUE_P74	WUE_P73	WUE_P72	WUE_P71	WUE_P70
		Power-on	0	0	0	0	0	0	0	0
		/RESET and WDT	0	0	0	0	0	0	0	0
		Wake-up from Pin Change	P	P	P	P	P	P	P	P
0X2B	Bank 0, R2B SPICR	Bit Name	CES	SPIE	SRO	SSE	SDOC	SBRS2	SBRS1	SBRS0
		Power-on	0	0	0	0	0	0	0	0
		/RESET and WDT	0	0	0	0	0	0	0	0
		Wake-up from Pin Change	P	P	P	P	P	P	P	P
0X2C	Bank 0, R2C SPIS	Bit Name	DORD	TD1	TD0	0	OD3	OD4	0	RBF
		Power-on	0	0	0	0	0	0	0	0
		/RESET and WDT	0	0	0	0	0	0	0	0
		Wake-up from Pin Change	P	P	P	0	P	P	0	P
0X2D	Bank 0, R2D SPIR	Bit Name	SRB7	SRB6	SRB5	SRB4	SRB3	SRB2	SRB1	SRB0
		Power-on	U	U	U	U	U	U	U	U
		/RESET and WDT	P	P	P	P	P	P	P	P
		Wake-up from Pin Change	P	P	P	P	P	P	P	P
0X2E	Bank 0, R2E SPIW	Bit Name	SWB7	SWB6	SWB5	SWB4	SWB3	SWB2	SWB1	SWB0
		Power-on	U	U	U	U	U	U	U	U
		/RESET and WDT	P	P	P	P	P	P	P	P
		Wake-up from Pin Change	P	P	P	P	P	P	P	P
0X2F	Bank 0, R2F WUCR1	Bit Name	0	SPIWE	LVDWE	ICWE	0	CMP2WE	CMP1WE	EXWE
		Power-on	0	0	0	0	0	0	0	0
		/RESET and WDT	0	0	0	0	0	0	0	0
		Wake-up from Pin Change	0	P	P	P	P	P	P	P



(Continuation)

Addr	Bank Name	Reset Type	Bit 7	Bit 6	Bit 5	Bit 4	Bit 3	Bit 2	Bit 1	Bit 0
0X32	Bank 0, R32 URCR1	Bit Name	URTD8	UMODE1	UMODE0	BRATE2	BRATE1	BRATE0	UTBE	TXE
		Power-on	U	0	0	0	0	0	1	0
		/RESET and WDT	P	0	0	0	0	0	1	0
		Wake-up from Pin Change	P	P	P	P	P	P	P	P
0X33	Bank 0, R33 URCR2	Bit Name	0	0	SBIM1	SBIM0	UINVEN	0	0	0
		Power-on	0	0	0	0	0	0	0	0
		/RESET and WDT	0	0	0	0	0	0	0	0
		Wake-up from Pin Change	0	0	P	P	P	0	0	0
0X34	Bank 0, R34 URS	Bit Name	URRD8	EVEN	PRE	PRERR	OVERR	FMERR	URBF	RXE
		Power-on	U	0	0	0	0	0	0	0
		/RESET and WDT	P	0	0	0	0	0	0	0
		Wake-up from Pin Change	P	P	P	P	P	P	P	P
0X35	Bank 0, R35 URRD	Bit Name	URRD7	URRD6	URRD5	URRD4	URRD3	URRD2	URRD1	URRD0
		Power-On	U	U	U	U	U	U	U	U
		/RESET and WDT	P	P	P	P	P	P	P	P
		Wake-up from Pin Change	P	P	P	P	P	P	P	P
0X36	Bank 0, R36 URTD	Bit Name	URTD7	URTD6	URTD5	URTD4	URTD3	URTD2	URTD1	URTD0
		Power-on	U	U	U	U	U	U	U	U
		/RESET and WDT	P	P	P	P	P	P	P	P
		Wake-up from Pin Change	P	P	P	P	P	P	P	P
0X37	Bank 0, R37 TBPTL	Bit Name	TB7	TB6	TB5	TB4	TB3	TB2	TB1	TB0
		Power-On	0	0	0	0	0	0	0	0
		/RESET and WDT	0	0	0	0	0	0	0	0
		Wake-up from Pin Change	P	P	P	P	P	P	P	P
0X38	Bank 0, R38 TBPTH	Bit Name	HLB	GP1	GP0	TB12	TB11	TB10	TB9	TB8
		Power-on	0	0	0	0	0	0	0	0
		/RESET and WDT	0	0	0	0	0	0	0	0
		Wake-up from Pin Change	P	P	P	P	P	P	P	P
0X39	Bank 0, R39 CMP1CR	Bit Name	C1RS	CP1OUT	CMP1COS1	CMP1COS0	CP1NS	CP1PS	CP1NRE	CP1NRDT
		Power-on	0	0	0	0	0	0	0	0
		/RESET and WDT	P	P	P	P	P	P	P	P
		Wake-up from Pin Change	P	P	P	P	P	P	P	P
0X3C	Bank 0, R3C CMP2CR	Bit Name	C2RS	CP2OUT	CMP2COS1	CMP2COS0	CP2NS	CP2PS	CP2NRE	CP2NRDT
		Power-on	0	0	0	0	0	0	0	0
		/RESET and WDT	0	0	0	0	0	0	0	0
		Wake-up from Pin Change	P	P	0	0	P	P	0	0
0X43	Bank 0, R43 CPIRLC ON	Bit Name	BG2OUT	C2IRL2	C2IRL1	C2IRL0	BG1OUT	C1IRL2	C1IRL1	C1IRL0
		Power-on	0	0	0	0	0	0	0	0
		/RESET and WDT	0	0	0	0	0	0	0	0
		Wake-up from Pin Change	P	P	P	P	P	P	P	P

(Continuation)

Address	Bank Name	Reset Type	Bit 7	Bit 6	Bit 5	Bit 4	Bit 3	Bit 2	Bit 1	Bit 0
0X48	Bank 0, R48 TC1CR	Bit Name	TC1CAP	TC1S	TC1CK1	TC1CK0	TC1M	TC1ES	0	0
		Power-on	0	0	0	0	0	0	0	0
		/RESET and WDT	0	0	0	0	0	0	0	0
		Wake-up from Pin Change	P	P	P	P	P	P	0	0
0X49	Bank 0, R49 TCR1DA	Bit Name	TCR1DA7	TCR1DA6	TCR1DA5	TCR1DA4	TCR1DA3	TCR1DA2	TCR1DA1	TCR1DA0
		Power-on	0	0	0	0	0	0	0	0
		/RESET and WDT	0	0	0	0	0	0	0	0
		Wake-up from Pin Change	P	P	P	P	P	P	P	P
0X4A	Bank 0, R4A TCR1DB	Bit Name	TCR1DB7	TCR1DB6	TCR1DB5	TCR1DB4	TCR1DB3	TCR1DB2	TCR1DB1	TCR1DB0
		Power-on	0	0	0	0	0	0	0	0
		/RESET and WDT	0	0	0	0	0	0	0	0
		Wake-up from Pin Change	P	P	P	P	P	P	P	P
0X4B	Bank 0, R4B T2CR	Bit Name	0	0	TC2ES	TC2M	TC2S	TC2CK2	TC2CK1	TC2CK0
		Power-on	0	0	0	0	0	0	0	0
		/RESET and WDT	0	0	0	0	0	0	0	0
		Wake-up from Pin Change	0	0	P	P	P	P	P	P
0X4C	Bank 0, R4C TCR2DH	Bit Name	TCR2D15	TCR2D14	TCR2D13	TCR2D12	TCR2D11	TCR2D10	TCR2D9	TCR2D8
		Power-on	0	0	0	0	0	0	0	0
		/RESET and WDT	0	0	0	0	0	0	0	0
		Wake-up from Pin Change	P	P	P	P	P	P	P	P
0X4D	Bank 0, R4D TCR2DL	Bit Name	TCR2D7	TCR2D6	TCR2D5	TCR2D4	TCR2D3	TCR2D2	TCR2D1	TCR2D0
		Power-on	0	0	0	0	0	0	0	0
		/RESET and WDT	0	0	0	0	0	0	0	0
		Wake-up from Pin Change	P	P	P	P	P	P	P	P
0X4E	Bank 0, R4E TC3CR	Bit Name	TC3FF1	TC3FF0	TC3S	TC3CK2	TC3CK1	TC3CK0	TC3M1	TC3M0
		Power-on	0	0	0	0	0	0	0	0
		/RESET and WDT	0	0	0	0	0	0	0	0
		Wake-up from Pin Change	P	P	P	P	P	P	P	P
0X4F	Bank 0, R4F TC3RD	Bit Name	TCR3D7	TCR3D6	TCR3D5	TCR3D4	TCR3D3	TCR3D2	TCR3D1	TCR3D0
		Power-on	0	0	0	0	0	0	0	0
		/RESET and WDT	0	0	0	0	0	0	0	0
		Wake-up from Pin Change	P	P	P	P	P	P	P	P
0X05	Bank 1, R5 P5PHCR	Bit Name	/PH57	/PH56	/PH55	/PH54	/PH53	/PH52	/PH51	/PH50
		Power-on	1	1	1	1	1	1	1	1
		/RESET and WDT	1	1	1	1	1	1	1	1
		Wake-Up from Pin Change	P	P	P	P	P	P	P	P
0X06	Bank 1, R6 P6PHCR	Bit Name	/PH67	/PH66	/PH65	/PH64	/PH63	/PH62	/PH61	/PH60
		Power-on	1	1	1	1	1	1	1	1
		/RESET and WDT	1	1	1	1	1	1	1	1
		Wake-up from Pin Change	P	P	P	P	P	P	P	P



(Continuation)

Address	Bank Name	Reset Type	Bit 7	Bit 6	Bit 5	Bit 4	Bit 3	Bit 2	Bit 1	Bit 0
0X07	Bank 1, R7 P7PHCR	Bit Name	/PH77	/PH76	/PH75	/PH74	/PH73	/PH72	/PH71	/PH70
		Power-on	1	1	1	1	1	1	1	1
		/RESET and WDT	1	1	1	1	1	1	1	1
		Wake-up from Pin Change	P	P	P	P	P	P	P	P
0X08	Bank 1, R8 P8PHCR	Bit Name	/PH87	/PH86	/PH85	/PH84	/PH83	/PH82	/PH81	/PH80
		Power-on	1	1	1	1	1	1	1	1
		/RESET and WDT	1	1	1	1	1	1	1	1
		Wake-up from Pin Change	P	P	P	P	P	P	P	P
0X09	Bank 1, R9 P9PHCR	Bit Name	/PH97	/PH96	/PH95	/PH94	/PH93	/PH92	/PH91	/PH90
		Power-on	1	1	1	1	1	1	1	1
		/RESET and WDT	1	1	1	1	1	1	1	1
		Wake-up from Pin Change	P	P	P	P	P	P	P	P
0X0B	Bank 1, RB P5PLCR	Bit Name	/PL57	/PL56	/PL55	/PL54	/PL53	/PL52	/PL51	/PL50
		Power-on	1	1	1	1	1	1	1	1
		/RESET and WDT	1	1	1	1	1	1	1	1
		Wake-up from Pin Change	P	P	P	P	P	P	P	P
0X0C	Bank 1, RC P6PLCR	Bit Name	/PL67	/PL66	/PL65	/PL64	/PL63	/PL62	/PL61	/PL60
		Power-on	1	1	1	1	1	1	1	1
		/RESET and WDT	1	1	1	1	1	1	1	1
		Wake-up from Pin Change	P	P	P	P	P	P	P	P
0X0D	Bank 1, RD P7PLCR	Bit Name	/PL77	/PL76	/PL75	/PL74	/PL73	/PL72	/PL71	/PL70
		Power-on	1	1	1	1	1	1	1	1
		/RESET and WDT	1	1	1	1	1	1	1	1
		Wake-up from Pin Change	P	P	P	P	P	P	P	P
0X0E	Bank 1, RE P8PLCR	Bit Name	/PL87	/PL86	/PL85	/PL84	/PL83	/PL82	/PL81	/PL80
		Power-on	1	1	1	1	1	1	1	1
		/RESET and WDT	1	1	1	1	1	1	1	1
		Wake-up from Pin Change	P	P	P	P	P	P	P	P
0X0F	Bank 1, RF P9PLCR	Bit Name	/PL97	/PL96	/PL95	/PL94	/PL93	/PL92	/PL91	/PL90
		Power-on	1	1	1	1	1	1	1	1
		/RESET and WDT	1	1	1	1	1	1	1	1
		Wake-up from Pin Change	P	P	P	P	P	P	P	P

(Continuation)

Address	Bank Name	Reset Type	Bit 7	Bit 6	Bit 5	Bit 4	Bit 3	Bit 2	Bit 1	Bit 0
0X11	Bank 1, R11 P5HD/SCR	Bit Name	/H57	/H56	/H55	/H54	/H53	/H52	/H51	/H50
		Power-on	1	1	1	1	1	1	1	1
		/RESET and WDT	1	1	1	1	1	1	1	1
		Wake-up from Pin Change	P	P	P	P	P	P	P	P
0X12	Bank 1, R12 P6HD/SCR	Bit Name	/H67	/H66	/H65	/H64	/H63	/H62	/H61	/H60
		Power-on	1	1	1	1	1	1	1	1
		/RESET and WDT	1	1	1	1	1	1	1	1
		Wake-up from Pin Change	P	P	P	P	P	P	P	P
0X13	Bank 1, R13 P7HD/SCR	Bit Name	/H77	/H76	/H75	/H74	/H73	/H72	/H71	/H70
		Power-on	1	1	1	1	1	1	1	1
		/RESET and WDT	1	1	1	1	1	1	1	1
		Wake-up from Pin Change	P	P	P	P	P	P	P	P
0X14	Bank 1, R14 P8HD/SCR	Bit Name	/H87	/H86	/H85	/H84	/H83	/H82	/H81	/H80
		Power-on	1	1	1	1	1	1	1	1
		/RESET and WDT	1	1	1	1	1	1	1	1
		Wake-up from Pin Change	P	P	P	P	P	P	P	P
0X15	Bank 1, R15 P9HD/SCR	Bit Name	/H97	/H96	/H95	/H94	/H93	/H92	/H91	/H90
		Power-on	1	1	1	1	1	1	1	1
		/RESET and WDT	1	1	1	1	1	1	1	1
		Wake-up from Pin Change	P	P	P	P	P	P	P	P
0X17	Bank 1, R17 P5ODCR	Bit Name	OD57	OD56	OD55	OD54	OD53	OD52	OD51	OD50
		Power-on	0	0	0	0	0	0	0	0
		/RESET and WDT	0	0	0	0	0	0	0	0
		Wake-up from Pin Change	P	P	P	P	P	P	P	P
0X18	Bank 1, R18 P6ODCR	Bit Name	OD67	OD66	OD65	OD64	OD63	OD62	OD61	OD60
		Power-on	0	0	0	0	0	0	0	0
		/RESET and WDT	0	0	0	0	0	0	0	0
		Wake-up from Pin Change	P	P	P	P	P	P	P	P
0X19	Bank 1, R19 P7ODCR	Bit Name	OD77	OD76	OD75	OD74	OD73	OD72	OD71	OD70
		Power-on	0	0	0	0	0	0	0	0
		/RESET and WDT	0	0	0	0	0	0	0	0
		Wake-up from Pin Change	P	P	P	P	P	P	P	P
0X1A	Bank 1, R1A P8ODCR	Bit Name	OD87	OD86	OD85	OD84	OD83	OD82	OD81	OD80
		Power-on	0	0	0	0	0	0	0	0
		/RESET and WDT	0	0	0	0	0	0	0	0
		Wake-up from Pin Change	P	P	P	P	P	P	P	P



(Continuation)

Address	Bank Name	Reset Type	Bit 7	Bit 6	Bit 5	Bit 4	Bit 3	Bit 2	Bit 1	Bit 0
0X1B	Bank 1, R1B P9ODCR	Bit Name	OD97	OD96	OD95	OD94	OD93	OD92	OD91	OD90
		Power-on	0	0	0	0	0	0	0	0
		/RESET and WDT	0	0	0	0	0	0	0	0
		Wake-up from Pin Change	P	P	P	P	P	P	P	P
0X1D	Bank 1, R1D IRCS	Bit Name	0	0	RCM1	RCM0	0	0	0	0
		Power-on	0	0	0	0	0	0	0	0
		/RESET and WDT	0	0	0	0	0	0	0	0
		Wake-up from Pin Change	P	P	P	P	P	P	P	P
0X1F	Bank 1, R1F EEPROM Control	Bit Name	RD	WR	EEWE	EEDF	EEPC	0	0	0
		Power-on	0	0	0	0	0	0	0	0
		/RESET and WDT	0	0	0	0	0	0	0	0
		Wake-Up from Pin Change	P	P	P	P	P	P	P	P
0X20	Bank 1, R20 EEPROM ADDR	Bit Name	EERA7	EERA6	EERA5	EERA4	EERA3	EERA2	EERA1	EERA0
		Power-on	0	0	0	0	0	0	0	0
		/RESET and WDT	0	0	0	0	0	0	0	0
		Wake-up from Pin Change	P	P	P	P	P	P	P	P
0X21	Bank 1, R21 EEPROM DATA	Bit Name	EERD7	EERD6	EERD5	EERD4	EERD3	EERD2	EERD1	EERD0
		Power-on	0	0	0	0	0	0	0	0
		/RESET and WDT	0	0	0	0	0	0	0	0
		Wake-up from Pin Change	P	P	P	P	P	P	P	P
0X23	Bank 1, R23 I2CCR1	Bit Name	Strobe/ Pend	IMS	ISS	STOP	SAR_ EMPTY	ACK	FULL	EMPTY
		Power-on	0	0	0	0	U	U	U	U
		/RESET and WDT	0	0	0	0	U	U	U	U
		Wake-up from Pin Change	P	P	P	P	P	P	P	P
0X24	Bank 1, R24 I2CCR2	Bit Name	I2CBF	GCEN	0	0	I2CTS1	I2CTS0	0	I2CEN
		Power-on	0	0	0	0	0	0	0	0
		/RESET and WDT	0	0	0	0	0	0	0	0
		Wake-up from Pin Change	0	0	0	0	P	P	P	P
0X25	Bank 1, R25 I2CSA	Bit Name	SA6	SA5	SA4	SA3	SA2	SA1	SA0	IRW
		Power-on	0	0	0	0	0	0	0	0
		/RESET and WDT	0	0	0	0	0	0	0	0
		Wake-up from Pin Change	P	P	P	P	P	P	P	P
0X26	Bank 1, R26 I2CDA	Bit Name	DA7	DA6	DA5	DA4	DA3	DA2	DA1	DA0
		Power-on	0	0	0	0	0	0	0	0
		/RESET and WDT	0	0	0	0	0	0	0	0
		Wake-up from Pin Change	P	P	P	P	P	P	P	P

(Continuation)

Address	Bank Name	Reset Type	Bit 7	Bit 6	Bit 5	Bit 4	Bit 3	Bit 2	Bit 1	Bit 0
0X27	Bank 1, R27 I2CDB	Bit Name	DB7	DB6	DB5	DB4	DB3	DB2	DB1	DB0
		Power-on	0	0	0	0	0	0	0	0
		/RESET and WDT	0	0	0	0	0	0	0	0
		Wake-up from Pin Change	P	P	P	P	P	P	P	P
0X28	Bank 1, R28 I2CA	Bit Name	0	0	0	0	0	0	DA9	DA8
		Power-on	0	0	0	0	0	0	0	0
		/RESET and WDT	0	0	0	0	0	0	0	0
		Wake-up from Pin Change	P	P	P	P	P	P	P	P
0X2A	Bank 1, R2A PWMER	Bit Name	0	0	0	0	0	0	PWMBE	PWMAE
		Power-on	0	0	0	0	0	0	0	0
		/RESET and WDT	0	0	0	0	0	0	0	0
		Wake-up from Pin Change	0	0	0	0	0	P	P	P
0X2B	Bank 1, R2B TIMEN	Bit Name	0	0	0	0	0	0	TBEN	TAEN
		Power-on	0	0	0	0	0	0	0	0
		/RESET and WDT	0	0	0	0	0	0	0	0
		Wake-up from Pin Change	0	0	0	0	0	P	P	P
0X2F	Bank 1, R2F PWMACR	Bit Name	0	0	0	0	TRCBA	0	0	0
		Power-on	0	0	0	0	0	0	0	0
		/RESET and WDT	0	0	0	0	0	0	0	0
		Wake-up from Pin Change	0	0	0	0	P	0	0	0
0X30	Bank 1, R30 PWMBCR	Bit Name	0	0	0	0	TRCBB	0	0	0
		Power-on	0	0	0	0	0	0	0	0
		/RESET and WDT	0	0	0	0	0	0	0	0
		Wake-up from Pin Change	0	0	0	0	P	0	0	0
0X32	Bank 1, R32 TACR	Bit Name	0	0	0	0	0	TAP2	TAP1	TAP0
		Power-on	0	0	0	0	0	0	0	0
		/RESET and WDT	0	0	0	0	0	0	0	0
		Wake-up from Pin Change	0	0	0	0	0	P	P	P
0X33	Bank 1, R33 TBCR	Bit Name	0	0	0	0	0	TBP2	TBP1	TBP0
		Power-on	0	0	0	0	0	0	0	0
		/RESET and WDT	0	0	0	0	0	0	0	0
		Wake-up from Pin Change	0	0	0	0	0	P	P	P
0X35	Bank 1, R35 TAPRDH	Bit Name	PRDA[9]	PRDA[8]	PRDA[7]	PRDA[6]	PRDA[5]	PRDA[4]	PRDA[3]	PRDA[2]
		Power-on	0	0	0	0	0	0	0	0
		/RESET and WDT	0	0	0	0	0	0	0	0
		Wake-up from Pin Change	P	P	P	P	P	P	P	P
0X36	Bank 1, R36 TBPRDH	Bit Name	PRDB[9]	PRDB[8]	PRDB[7]	PRDB[6]	PRDB[5]	PRDB[4]	PRDB[3]	PRDB[2]
		Power-on	0	0	0	0	0	0	0	0
		/RESET and WDT	0	0	0	0	0	0	0	0
		Wake-up from Pin Change	P	P	P	P	P	P	P	P

(Continuation)

Address	Bank Name	Reset Type	Bit 7	Bit 6	Bit 5	Bit 4	Bit 3	Bit 2	Bit 1	Bit 0
0X38	Bank 1, R38 TADTH	Bit Name	DTA[9]	DTA[8]	DTA[7]	DTA[6]	DTA[5]	DTA[4]	DTA[3]	DTA[2]
		Power-on	0	0	0	0	0	0	0	0
		/RESET and WDT	0	0	0	0	0	0	0	0
		Wake-up from Pin Change	P	P	P	P	P	P	P	P
0X39	Bank 1, R39 TBDTH	Bit Name	DTB[9]	DTB[8]	DTB[7]	DTB[6]	DTB[5]	DTB[4]	DTB[3]	DTB[2]
		Power-on	0	0	0	0	0	0	0	0
		/RESET and WDT	0	0	0	0	0	0	0	0
		Wake-up from Pin Change	P	P	P	P	P	P	P	P
0X3B	Bank 1, R3B PRDxL	Bit Name	0	0	0	0	PRDB[1]	PRDB[0]	PRDA[1]	PRDA[0]
		Power-on	0	0	0	0	0	0	0	0
		/RESET and WDT	0	0	0	0	0	0	0	0
		Wake-up from Pin Change	0	0	P	P	P	P	P	P
0X3C	Bank 1, R3C DTxL	Bit Name	0	0	0	0	DTB[1]	DTB[0]	DTA[1]	DTA[0]
		Power-on	0	0	0	0	0	0	0	0
		/RESET and WDT	0	0	0	0	0	0	0	0
		Wake-up from Pin Change	0	0	P	P	P	P	P	P

6.11.3 The Status of RST, T, and P of STATUS Register

A Reset condition is initiated by the following events:

- 1) A power-on condition
- 2) A high-low-high pulse on /RESET pin
- 3) Watchdog timer time-out

The values of T and P as listed in the following table are used to check how the processor wakes up.

■ Values of RST, T, and P after RESET:

Reset Type	T	P
Power on	1	1
/RESET during Operating mode	P*	P*
/RESET wake-up during Sleep mode	1	0
WDT during Operating mode	0	P*
WDT wake-up during Sleep mode	0	0
Wake-up on pin change during Sleep mode	1	0

* Previous status before reset

The table below shows the events that may affect the status of T and P.

■ Status of T and P Being Affected by Events

Event	T	P
Power on	1	1
WDTC instruction	1	1
WDT time-out	0	P*
SLEP instruction	1	0
Wake-up on pin change during Sleep mode	1	0

* Previous status before reset

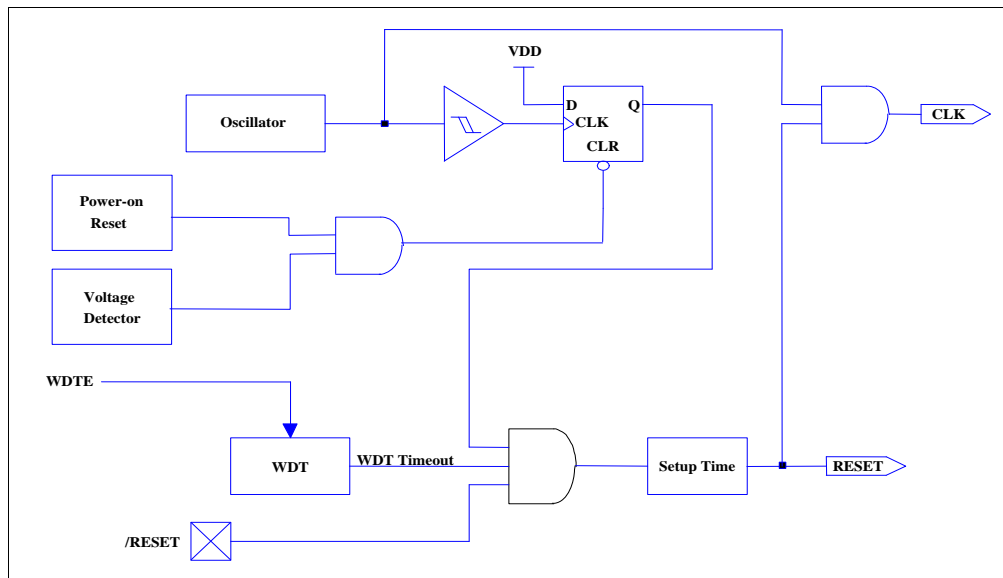

Figure 6-24 Controller Reset Block Diagram

6.12 Interrupt

6.12.1 Interrupt for EM78F644/642/641/544/542/541N

■ The EM78F644/544N has 13 interrupts (3 external, 10 internal) as listed below:

Interrupt Source		Enable Condition	Int. Flag	Int. Vector	Priority
Internal / External	Reset	-	-	0000	High 0
External	INT	ENI + EXIE=1	EXIF	0003	1
External	Port 6 pin change	ENI + ICIE=1	ICIF	0006	2
Internal	TCC	ENI + TCIE=1	TCIF	0009	3
Internal	SPI	ENI + SPIIE=1	SPIIF	0012	4
External	Comparator 2	ENI+COMP2IE=1	CMP2IF	0015	5
Internal	TC1	ENI + TC1IE=1	TC1IF	0018	6
Internal	UART Transmit	ENI + UTIE=1	TBEF	001B	7
Internal	UART Receive	ENI + URIE=1	RBFF	001E	8
Internal	UART Receive error	ENI+UERRIE=1	UERRIF	0021	9
Internal	TC2	ENI + TC2IE=1	TC2IF	0024	10
Internal	TC3	ENI + TC3IE=1	TC3IF	0027	11
Internal	PWMA	ENI+PWMAIE=1	PWMAIF	002A	12
Internal	PWMB	ENI+PWMBIE=1	PWMBIF	002D	13

- The **EM78F642/542N** has 6 interrupts (3 external, 3 internal) listed below:

Interrupt Source		Enable Condition	Int. Flag	Int. Vector	Priority
Internal / External	Reset	-	-	0000	High 0
External	INT	ENI + EXIE=1	EXIF	0003	1
External	Port 6 pin change	ENI + ICIE=1	ICIF	0006	2
Internal	TCC	ENI + TCIE=1	TCIF	0009	3
External	Comparator2	ENI+CMP2IE=1	CMP2IF	0015	4
Internal	TC2	ENI + TCIE2=1	TCIF2	0024	5
Internal	TC3	ENI + TCIE3=1	TCIF3	0027	6

- The **EM78F641/541N** has 5 interrupts (3 external, 2 internal) as listed below:

Interrupt Source		Enable Condition	Int. Flag	Int. Vector	Priority
Internal / External	Reset	-	-	0000	High 0
External	INT	ENI + EXIE=1	EXIF	0003	1
External	Port 6 pin change	ENI + ICIE=1	ICIF	0006	2
Internal	TCC	ENI + TCIE=1	TCIF	0009	3
External	Comparator 2	ENI+CMP2IE=1	CMP2IF	0015	4
Internal	TC3	ENI + TC3IE=1	TC3IF	0027	5

RE and RF are the Interrupt Status registers that record the interrupt requests in the relative flags/bits. IOCE and IOCF are the Interrupt Mask registers. The global interrupt is enabled by the ENI instruction and disabled by the DISI instruction. When one of the enabled interrupts occurs, the next instruction will be fetched from their individual address. The interrupt flag bit must be cleared by instructions before leaving the interrupt service routine and before interrupts are enabled to avoid recursive interrupts.

The flag (except ICIF bit) in the Interrupt Status Register (RF and RE) is set regardless of the status of its mask bit or the execution of ENI. The RETI instruction ends the interrupt routine and enables the global interrupt (the execution of ENI).

The external interrupt is equipped with an on-chip digital noise rejection circuit (input pulse of less than **8 system clock time** is eliminated as noise), **but in Low Crystal oscillator (LXT) mode, the noise rejection circuit is disabled**. When an interrupt (Falling edge) is generated by the External interrupt (when enabled), the next instruction will be fetched from Address 003H.

Before the interrupt subroutine is executed, the contents of ACC and the R3 and R4 registers are saved by hardware. If another interrupt occurs, the ACC, R3 and R4 will be replaced by the new interrupt. After the interrupt service routine is completed, ACC, R3, and R4 will be pushed back.

6.12.2 Interrupt for EM78F648/548N

- The EM78F648/548N has 18 interrupts (4 external, 14 internal) listed below:

Interrupt Source	Enable Condition	Int. Flag	Int. Vector	Priority	
Internal / External	Reset	-	-	0000	High 0
External	INT	ENI + EXIE=1	EXIF	0003	1
External	Port 6 pin change	ENI + ICIE=1	ICIF	0006	2
Internal	TCC	ENI + TCIE=1	TCIF	0009	3
Internal	LVD	ENI+LV DEN and LVDIE=1	LVDIF	000C	4
External	Comparator 1	ENI+CMP1IE=1	CMP1IF	000F	5
Internal	SPI	ENI + SPIIE=1	SPIIF	0012	6
External	Comparator 2	ENI+CMP2IE=1	CMP2IF	0015	7
Internal	TC1	ENI + TC1IE=1	TC1IF	0018	8
Internal	UART Transmit	ENI + UTIE=1	TBEF	001B	9
Internal	UART Receive	ENI + URIE=1	RBFF	001E	10
Internal	UART Receive error	ENI+UERRIE=1	UERRIF	0021	11
Internal	TC2	ENI + TC2IE=1	TC2IF	0024	12
Internal	TC3	ENI + TC3IE=1	TC3IF	0027	13
Internal	PWMA	ENI+PWMAIE=1	PWMAIF	002A	14
Internal	PWMB	ENI+PWMBIE=1	PWMBIF	002D	15
Internal	I2C Transmit	ENI+ I2CTIE	I2CTIF	0036	16
Internal	I2C Receive	ENI+ I2CRIE	I2CRIF	0039	17
Internal	I2C Stop	ENI+ I2CSTPIE	I2CSTPIF	003F	18

Bank 0 RC~RF are the Interrupt Status registers that record the interrupt requests in the relative flags/bits. Bank 0 R1C~R1F is the Interrupt Mask register. The global interrupt is enabled by the ENI instruction and disabled by the DISI instruction. When one of the interrupts (enabled) occurs, the next instruction will be fetched from their individual address. The interrupt flag bit must be cleared by instructions before leaving the interrupt service routine and before interrupts are enabled to avoid recursive interrupts.

The flag (except ICIF bit delete) in the Interrupt Status Register is set regardless of the status of its mask bit or the execution of ENI. The RETI instruction ends the interrupt routine and enables the global interrupt (the execution of ENI).

The External interrupt is equipped with digital noise rejection circuit (input pulse of less than **8 system clocks time** is eliminated as noise), **but in Low XTAL oscillator (LXT) mode the noise rejection circuit is disabled**. When an interrupt (Falling edge) is generated by the External interrupt (when enabled), the next instruction will be fetched from Address 003H.

Before the interrupt subroutine is executed, the contents of ACC and the R3 and R4 registers are saved by hardware. If another interrupt occurs, the ACC, R3 and R4 will be replaced by the new interrupt. After the interrupt service routine is completed, ACC, R3, and R4 will be pushed back.

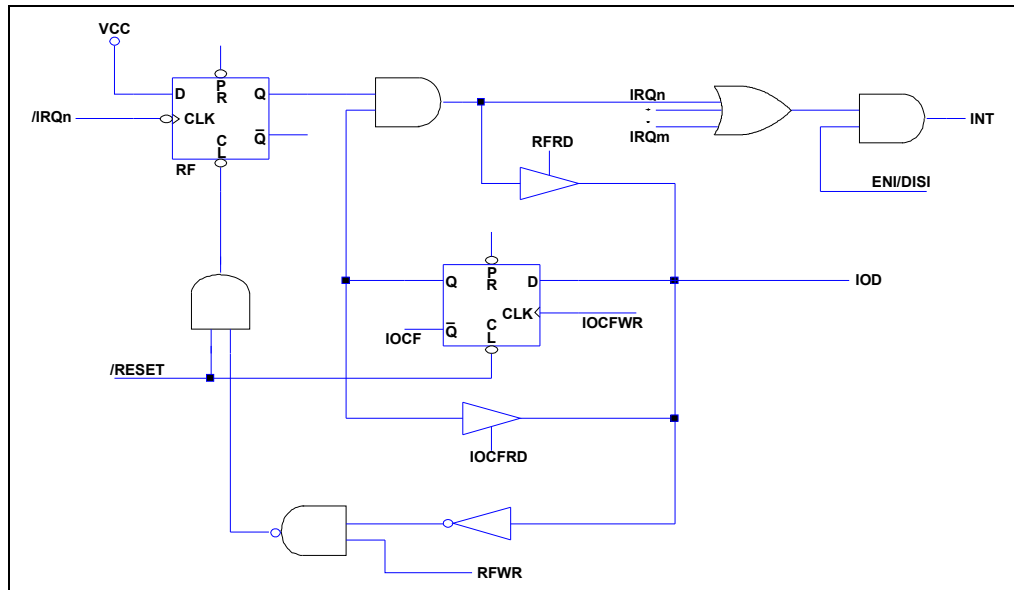

Figure 6-25a Interrupt Input Circuit Diagram

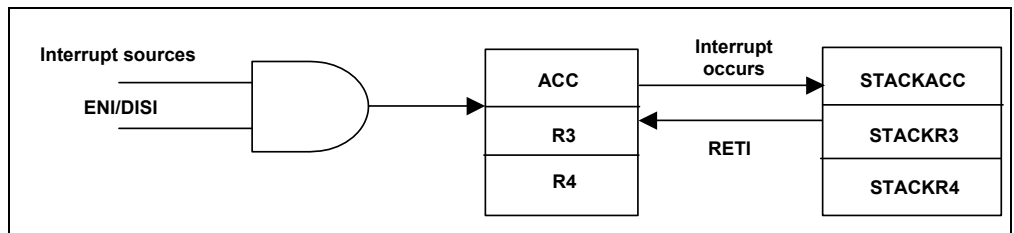

Figure 6-25b Interrupt Backup Diagram

6.13 LVD (Low Voltage Detector) for EM78F648/548N

When an unstable power source condition occurs, such as external power noise interference or EMS test condition, a violent power vibration is generated. At the same time, the V_{dd} becomes unstable as it maybe operating below working voltage. When the system is operating under low voltage condition, the IC kernel will automatically keep all register status.

6.13.1 LVD Level Control

LVD property is set at Bank 0 R12 (Section 6.3.15). Bits 1 and 0 operation mode is as follows.

Bit 7	Bit 6	Bit 5	Bit 4	Bit 3	Bit 2	Bit 1	Bit 0
0	0	0	0	LVDEN	/LVD	LVD1	LVD0

Bit 1~Bit 0 (LVD1~LVD0): Low Voltage Detect level control bits

6.13.2 LVD Interrupt

The LVD status and interrupt flag refers to Bank 0 RC (Section 6.3.9) and Bank 0 R1C (Section 6.3.20). Their respective Bit 7 operation mode is as follows.

■ LVD Interrupt Flag (Bank 0 RC)

Bit 7	Bit 6	Bit 5	Bit 4	Bit 3	Bit 2	Bit 1	Bit 0
LVDIF	0	SPIF	PWMBIF	PWMAIF	EXIF	ICIF	TCIF

Bit 7 (LVDIF): Low Voltage Detector Interrupt Flag

When LVD1, LVD0 = "0, 0", $V_{dd} > 2.2V$, LVDIF is "0", $V_{dd} \leq 2.2V$, set LVDIF to "1". LVDIF is reset to "0" by software.

When LVD1, LVD0 = "0, 1", $V_{dd} > 3.3V$, LVDIF is "0", $V_{dd} \leq 3.3V$, set LVDIF to "1". LVDIF is reset to "0" by software.

When LVD1, LVD0 = "1, 0", $V_{dd} > 4.0V$, LVDIF is "0", $V_{dd} \leq 4.0V$, set LVDIF to "1". LVDIF is reset to "0" by software.

When LVD1, LVD0 = "1, 1", $V_{dd} > 4.5V$, LVDIF is "0", $V_{dd} \leq 4.5V$, set LVDIF to "1". LVDIF is reset to "0" by software.

■ LVD Interrupt Enable (Bank 0 R1C)

Bit 7	Bit 6	Bit 5	Bit 4	Bit 3	Bit 2	Bit 1	Bit 0
LVDIE	0	SPIE	PWMBIE	PWMAIE	EXIE	ICIE	TCIE

Bit 7 (LVDIE): LVDIF interrupt enable bit

0: Disable LVDIF interrupt

1: Enable LVDIF interrupt

6.13.3 LVD Function Setup

To setup the LVD function, perform the following steps:

- 1) Set the LVDEN to "1", then use Bits 1, 0 (LVD1, LVD0) of Register RB to set the LVD interrupt level
- 2) Enable LVDIE
- 3) Wait for the LVD interrupt to occur
- 4) Clear the LVD interrupt flag

NOTE

- The internal LVD module uses the internal circuit to match low voltage detection. When the LVDEN is set to enable the LVD module, the current consumption will increase to about 10 μ A.
- During Sleep mode, the LVD module continues to operate. If the device voltage drops slowly and crosses the detection point, the LVDIF bit will be set and the device will not wake-up from Sleep mode. Until the other wake-up sources wakes-up the EM78F648/548N, the LVD interrupt flag setting will remain at priority status.
- When the system resets, the LVD flag is cleared.

Figure 6-26 below shows the LVD module detection point in an external voltage condition.

- When Vdd drops but above VLVD, LVDIF is kept at “0”.
- When Vdd drops below VLVD, LVDIF is set to “1”. If the global ENI is enabled, LVDIF is also set to “1” and the next instruction will branch to interrupt vector. The LVD interrupt flag is cleared to “0” by software.
- When Vdd drops below VRESET at less than 80 μ s, the system will keep all the register status and halts its operation, but oscillation remains active.
- When Vdd drops below VRESET at more than 80 μ s, system Reset will occur.

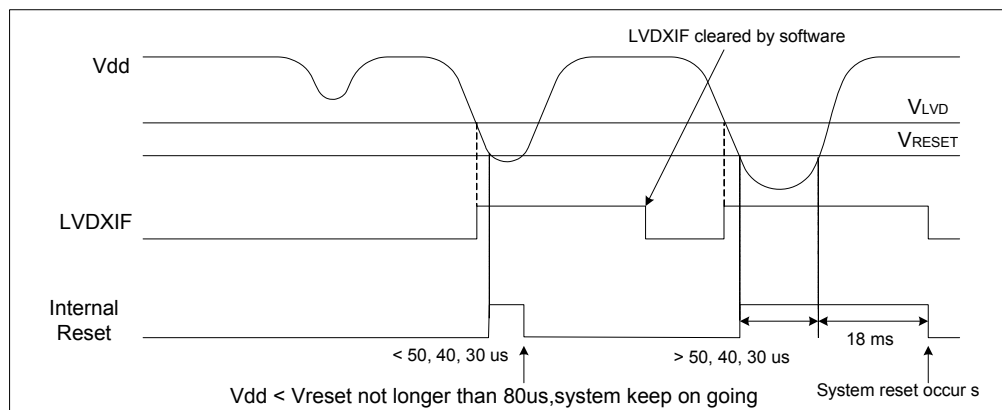

Figure 6-26 LVD Waveform Characteristics Showing Detection Point in an External Voltage Condition

6.14 Data EEPROM

The Data EEPROM is readable and writable during normal operation over the whole V_{DD} range. The operation for Data EEPROM is based on a single byte. A write operation makes an erase-then-write cycle to take place on the allocated byte.

The Data EEPROM memory provides high erase and write cycles. A byte write automatically erases the location and writes the new value.

The following are the steps to write to or read data from the EEPROM:

- 1) Set the **EEPC** bit to “1” for enable the EEPROM power
- 2) Write the address to EERA8~EERA0 (512 bytes EEPROM address)
- 3) A. • Set the **EEWE** bit to “1”, if the write function is employed
 - Write the 8-bit value of the data to be programmed (256 bytes EEPROM data)
 - Set the **WR** bit to “1”, then; execute write function
 B. Set the **RD** bit to “1”, then; execute read function
- 4) A. Wait for the **EEDF** or **WR** to be cleared
 B. Wait for the **EEDF** to be cleared
- 5) For the next conversion, go to Step 2 as required
- 6) To save power and make sure the EEPROM are data not used, clear the **EEPC**.

6.15 Oscillator

6.15.1 Oscillator Modes

The EM78F64x/F54xN can be operated in the four different oscillator modes, such as Internal RC oscillator mode (IRC), External RC oscillator mode (ERC), High XTAL oscillator mode (HXT), and Low XTAL oscillator mode (LXT). User can select one of them by programming OSC2, OSC1, and OSC0 in the Code Option register. The following table depicts how these four modes are defined.

The maximum operation frequencies of the crystal/resonator under different V_{DD} voltages are listed in the table.

■ Oscillator Modes defined by OSC2 ~ OSC0

Mode	OSC2	OSC1	OSC0
XT (XTAL Oscillator mode)	0	0	0
HXT (High XTAL Oscillator mode)	0	0	1
LXT1 (Low XTAL1 Oscillator mode)	0	1	0
LXT2 (Low XTAL2 Oscillator mode)	0	1	1
IRC mode, OSC0 (P54) acts as I/O pin	1	0	0
IRC mode, OSC0 (P54) acts as RCOU pin	1	0	1
ERC mode, OSC0 (P54) acts as I/O pin	1	1	0
ERC mode, OSC0 (P54) acts as RCOU pin	1	1	1

In LXT1, LXT2, XT, HXT, and ERC modes, OSCI and OSCO are used. These pins cannot be used as normal I/O pins. In IRC mode, P55 is used as normal I/O pin.

NOTE

1. Frequency range of HXT mode is 20 MHz ~ 6 MHz.
2. Frequency range of XT mode is 6 MHz ~ 1 MHz.
3. Frequency range of LXT1 mode is 1 MHz ~ 100kHz.
4. Frequency range of XT mode is 32kHz.

■ Summary of Maximum Operating Speed:

Conditions	VDD	Fxt Max. (MHz)
Two cycles with two clocks	2.5	4.0
	3.0	8.0
	5.0	20.0

6.15.2 Crystal Oscillator/Ceramic Resonators (XTAL)

EM78F64x/54xN can be driven by an external clock signal through the OSCI pin as illustrated below.

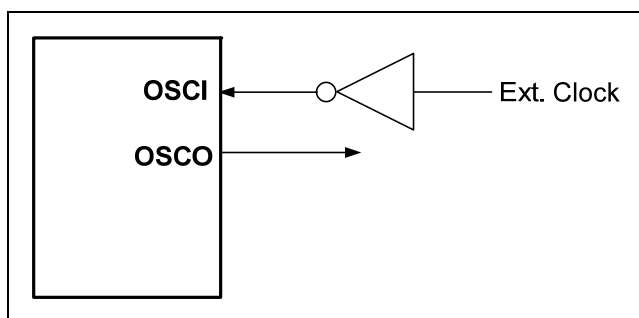

Figure 6-27a External Clock Input Circuit

In most applications, Pins OSCI and OSCO are connected with a crystal or ceramic resonator to generate oscillation as depicted in the circuit diagram below. The same thing applies under HXT or LXT mode. The following table (next page) provides the recommended values for C1 and C2. Since each resonator has its own attribute, you should refer to the pertinent resonator specification for appropriate C1/C2 values. RS, a serial resistor, may be necessary for AT strip cut crystal or low frequency mode.

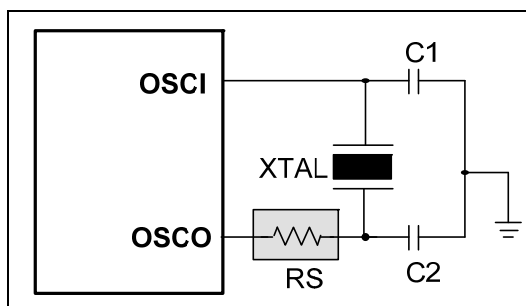

Figure 6-27b Crystal/Resonator Circuit

■ Capacitor Selection Guide for Crystal Oscillator or Ceramic Resonator:

Oscillator Type	Frequency Mode	Frequency	C1 (pF)	C2 (pF)
Ceramic Resonators	HXT	455kHz	100~150	100~150
		2.0 MHz	20~40	20~40
		4.0 MHz	10~30	10~30
Crystal Oscillator	LXT	32.768kHz	25	15
		100kHz	25	25
		200kHz	25	25
	HXT	455kHz	20~40	20~150
		1.0 MHz	15~30	15~30
		2.0 MHz	15	15
		4.0 MHz	15	15

6.15.3 External RC Oscillator Mode

For some applications that do not require a very precise timing calculation, the use of RC oscillator (see the figure below) offers a lot of cost savings. Nevertheless, it should be noted that the frequency of the RC oscillator is influenced by such factors as supply voltage, the values of the resistor (R_{ext}), the capacitor (C_{ext}), and even by the operation temperature. Moreover, the frequency also changes slightly from one chip to another due to the manufacturing process variations.

In order to maintain a stable system frequency, the values of the C_{ext} should be more than 20pF, and that the value of R_{ext} should be less than 1 M Ω . If the values cannot be kept within the prescribed range, the frequency can be easily affected by noise, humidity, and leakage.

The smaller the R_{ext} in the RC oscillator is, the faster its frequency will be. On the contrary, for very low R_{ext} values, for instance, 1 K Ω , the oscillator becomes unstable because the NMOS cannot discharge the current of the capacitance correctly.

Based on the above reasons, it must be kept in mind that all of the supply voltage, the operation temperature, the components of the RC oscillator, the package types, the PCB is layout, could affect the system frequency.

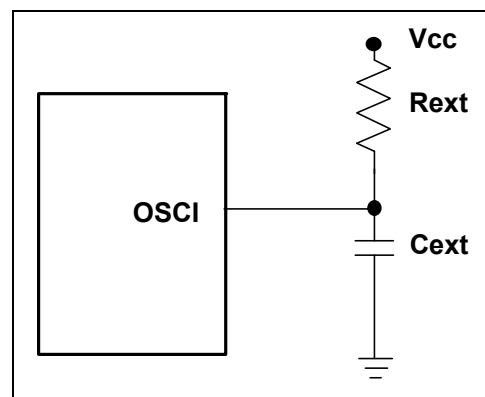

Figure 6-28 Circuit for External RC Oscillator Mode

■ RC Oscillator Frequencies:

Cext	Rext	Average Fosc 5V, 25°C	Average Fosc 3V, 25°C
20 pF	3.3k	3.5 MHz	3.2 MHz
	5.1k	2.5 MHz	2.3 MHz
	10k	1.30 MHz	1.25 MHz
	100k	140kHz	140kHz
100 pF	3.3k	1.27 MHz	1.21 MHz
	5.1k	850kHz	820kHz
	10k	450kHz	450kHz
	100k	48kHz	50kHz
300 pF	3.3k	560kHz	540kHz
	5.1k	370kHz	360kHz
	10k	196kHz	192kHz
	100k	20kHz	20kHz

Note: 1. Data are obtained from DIP package measurement.
 2. Data are provided for design reference only.

6.15.4 Internal RC Oscillator Mode

The EM78F64x/54xN series MCUs offer a versatile internal RC mode with default frequency value of 4 MHz. The internal RC oscillator mode has other frequencies (4 MHz, 16 MHz, 8 MHz, and 455kHz), that can be set by Code Option: RCM1 and RCM0. All these four main frequencies can be calibrated by programming the Code Option Bits C4~C0. The following tables show typical drift rates of the calibration.

■ F644/544N Internal RC Drift Rate (Ta=25°C, VDD=5 V± 5%, VSS=0V):

Internal RC	Drift Rate			
	Temperature (-40°C~85°C)	Voltage (2.4V~5.5V)	Process	Total
4 MHz	± 3%	± 5%	± 2.5%	± 10.5%
16 MHz*	± 3%	± 5%	± 2.5%	± 10.5%
8 MHz	± 3%	± 5%	± 2.5%	± 10.5%
455kHz	± 3%	± 5%	± 2.5%	± 10.5%

*16 MHz Operating Temperature: -40°C ~ 50°C

■ F642/542N Internal RC Drift Rate (Ta=25°C, VDD=5 V± 5%, VSS=0V):

Internal RC	Drift Rate			
	Temperature (-40°C~85°C)	Voltage (2.4V~5.5V)	Process	Total
1 MHz	± 5%	± 4%	± 2.5%	± 11.5%
4 MHz	± 5%	± 4%	± 2.5%	± 11.5%
8 MHz	± 5%	± 5%	± 2.5%	± 12.5%
16 MHz	± 5%	± 5%	± 2.5%	± 12.5%

■ **F641/541N** Internal RC Drift Rate ($T_a=25^{\circ}\text{C}$, $V_{DD}=5\text{V}\pm 5\%$, $V_{SS}=0\text{V}$)

Internal RC	Drift Rate			
	Temperature ($-40^{\circ}\text{C}\sim 85^{\circ}\text{C}$)	Voltage ($2.4\text{V}\sim 5.5\text{V}$)	Process	Total
4 MHz	$\pm 3\%$	$\pm 5\%$	$\pm 2.5\%$	$\pm 10.5\%$
16 MHz	$\pm 3\%$	$\pm 5\%$	$\pm 2.5\%$	$\pm 10.5\%$
8 MHz	$\pm 3\%$	$\pm 5\%$	$\pm 2.5\%$	$\pm 10.5\%$

■ **F648/548N** Internal RC Drift Rate ($T_a=25^{\circ}\text{C}$, $V_{DD}=5\text{V}\pm 5\%$, $V_{SS}=0\text{V}$)

Internal RC Frequency	Drift Rate			
	Temperature ($-40^{\circ}\text{C}\sim 85^{\circ}\text{C}$)	Voltage ($2.2\text{V}\sim 5.5\text{V}$)	Process	Total
455kHz	$\pm 5\%$	$\pm 5\%$	$\pm 4\%$	$\pm 14\%$
4 MHz	$\pm 5\%$	$\pm 5\%$	$\pm 4\%$	$\pm 14\%$
8 MHz	$\pm 5\%$	$\pm 5\%$	$\pm 4\%$	$\pm 14\%$
16 MHz	$\pm 5\%$	$\pm 5\%$	$\pm 4\%$	$\pm 14\%$

6.16 Power-on Considerations

Any microcontroller is not guaranteed to start operating properly before the power supply reaches its steady state. EM78F64x/54xN is equipped with a Power-On Voltage Detector (POVD) with a detection level of 2.0V. Power will work normally if the V_{dd} rises fast enough (50 ms or less). However, in critical applications, extra devices are still required to assist in solving power-up problems.

6.17 External Power-on Reset Circuit

The circuit diagram shown below implements an external RC to generate a reset pulse. The pulse width (time constant) should be kept long enough for V_{dd} to reach minimum operational voltage. Apply this circuit when the power supply has a slow rise time. Since the current leakage from the /RESET pin is about $\pm 5\ \mu\text{A}$, it is recommended that R should not be greater than 40 K Ω in order for the /RESET pin voltage to remain at below 0.2V. The diode (D) acts as a short circuit at the moment of power down. The capacitor (C) will discharge rapidly and fully. The current-limited resistor (R_{in}), will prevent high current or ESD (electrostatic discharge) from flowing into the /RESET pin.

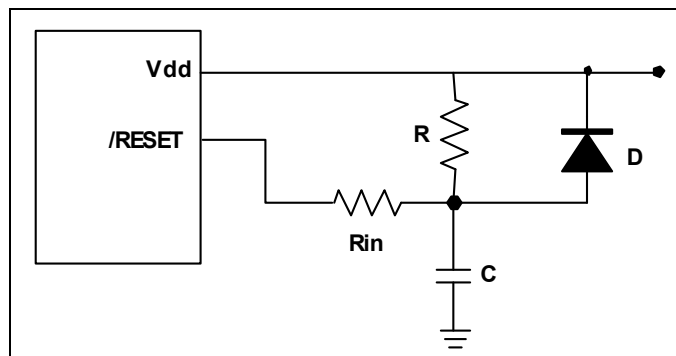

Figure 6-29 External Power-up Reset Circuit

6.18 Residue-Voltage Protection

When battery is replaced, device power (Vdd) is taken off but residue-voltage remains. The residue-voltage may trip below Vdd minimum, but not to zero. This condition may cause a poor power-on reset. Figures 6-30a and 6-30b show how to accomplish a proper residue-voltage protection circuit.

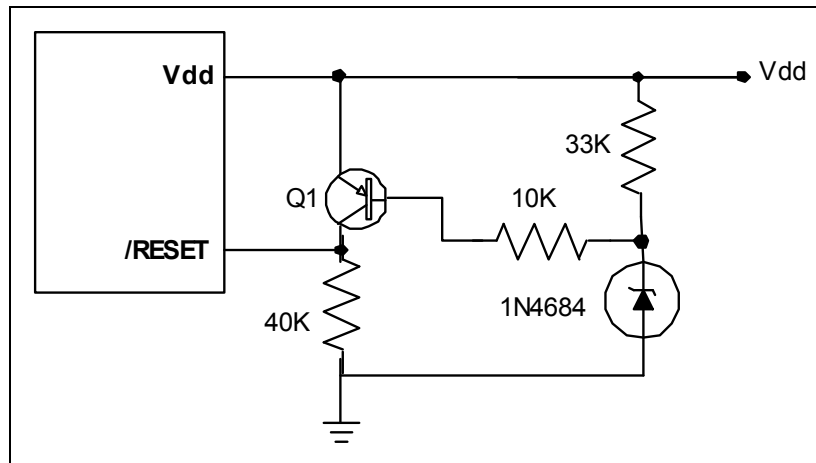

Figure 6-30a Residue Voltage Protection Circuit 1

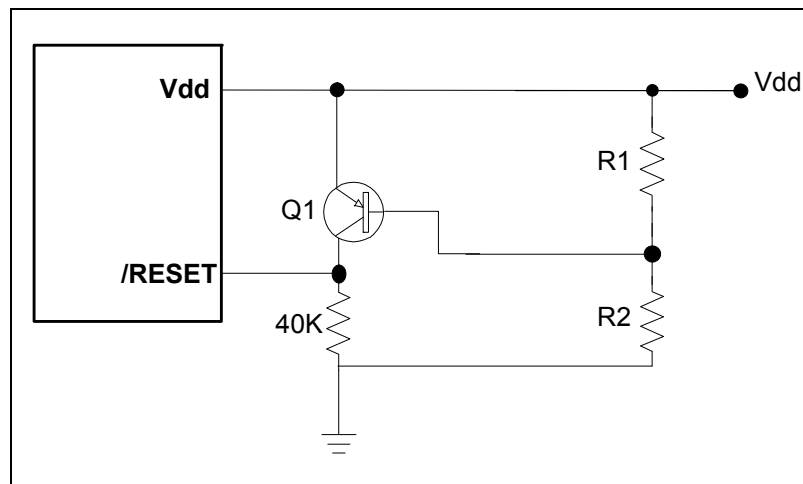

Figure 6-30b Residue Voltage Protection Circuit 2



6.19 Code Option Register

The EM78F648/644/642/641/548/544/542/541N have Code Option Words that are not part of the normal program memory. The option bits cannot be accessed during normal program execution.

Their respective Code Option Register and Customer ID Register arrangement distribution are as follows:

■ EM78F644/642/641/544/542/541N

Word 0	Word 1	Word 2
Bit 12 ~ Bit 0	Bit 12 ~ Bit 0	Bit 12 ~ Bit 0

■ EM78F648/548N

Word 0	Word 1	Word 2
Bit 14 ~ Bit 0	Bit 14 ~ Bit 0	Bit 14 ~ Bit 0

6.19.1 Code Option Register (Word 0)

6.19.1.1 EM78F644/642/641/544/542/541N Code Option Word 0

Word 0												
Bit 12	Bit 11	Bit 10	Bit 9	Bit 8	Bit 7	Bit 6	Bit 5	Bit 4	Bit 3	Bit 2	Bit 1	Bit 0
-	NRHL	NRE	RESET ENB	CLKS1	CLKS0	EN WDTB	OSC2	OSC1	OSC0	Protect		

Bit 12: Not used, set to "0" all the time.

Bit 11 (NRHL): Noise Rejection High/Low Pulse Define bit. INT pin is a falling edge trigger.

0: Pulses equal to $32/f_c$ [s] is regarded as signal (default)

1: Pulses equal to $8/f_c$ [s] is regarded as signal

NOTE

The noise rejection function is turned off in LXT2 and in Sleep mode.

Bit 10 (NRE): Noise Rejection Enable bit. The INT pin is a falling edge trigger.

0: Enable noise rejection (default)

1: Disable noise rejection

Note that in Low Crystal oscillator (LXT2) mode, the noise rejection circuit is always disabled.

Bit 9 (RESETENB): Reset Pin Enable Bit

0: P83 set to I/O pin (default)

1: P83 set to /RESET pin

NOTE

The "RESETENB" bit is NOT available in EM78F644/544N

Bit 8 ~ Bit 7 (CLKS1 ~ CLKS0): Instruction period option bit

Instruction Period	CLKS1	CLKS0
4 clocks (default)	0	0
2 clocks	0	1
8 clocks	1	0
16 clocks	1	1

Refer to the Instruction Set in Section 6.20.

NOTE

ELAN UICE only supports two or four clocks instruction period.

Bit 6 (ENWDTB): Watchdog Timer Enable bit

0: Disable (default)

1: Enable

Bit 5 ~ Bit 3 (OSC2 ~ OSC0): Oscillator Mode selection bits

Oscillator Modes as defined by OSC2 ~ OSC0:

Mode	OSC2	OSC1	OSC0
XT ¹ (Crystal oscillator mode) (default)	0	0	0
HXT ² (High Crystal oscillator mode)	0	0	1
LXT1 ³ (Low Crystal 1 oscillator mode)	0	1	0
LXT2 ⁴ (Low Crystal 2 oscillator mode)	0	1	1
IRC (Internal RC oscillator mode) P55, P54 act as I/O pin	1	0	0
IRC (Internal RC oscillator mode) P55 act as I/O pin P54 act as RCOU pin	1	0	1
ERC (External RC oscillator mode); P55 act as ERCin pin P54 act as I/O pin	1	1	0
ERC (External RC oscillator mode); P55 act as ERCin pin P54 act as RCOU pin with Open-Drain	1	1	1

¹ Frequency range of XT mode is 6 MHz ~ 1 MHz.

² Frequency range of HXT mode is 16 MHz ~ 6 MHz.

³ Frequency range of LXT1 mode is 1 MHz ~ 100kHz.

⁴ Frequency range of LXT2 mode is 32kHz.

Bit 2 ~ Bit 0 (Protect): Protect select bits as shown below:

Protect	Protect
1	Enable
0	Disable

6.19.1.1 EM78F648/548 Code Option Word 0

Word 0												
Bit 14	Bit 13	Bit 12	Bit 11	Bit 10	Bit 9	Bit 8	Bit 7	Bit 6	Bit 5	Bit 4	Bit 3	Bit 2 ~ Bit 0
COBS0	-	-	CLKS0	-	-	LVR1	LVR0	RESETEN	ENWDT	NRHL	NREB	Protect

Bit 14 (COBS0): IRC mode selection bit
0: Select IRC frequency from the code option
1: Select IRC frequency from the register

Bits 13~12: Not used, set to “0” all the time.

Bit 11 (CLKS0): Instruction period option bits

Instruction Period	CLKS0
4 clocks	0
2 clocks	1

Bits 10~9: Not used, set to “0” all the time.

Bits 8~7 (LVR1~LVR0): Low voltage reset enable bit

LVR1, LVR0	VDD reset level
00	NA
01	2.7V
10	3.7V
11	4.2V

Bit 6 (RESETEN): P83//RST pin selection bit
0: P83 pin
1: /RST pin

Bit 5 (ENWDT): WDT enable bit
0: Disable
1: Enable

Bit 4 (NRHL): Noise rejection high/low pulse definition bit
0: Pulses equal to $32/f_c$ [s] is regarded as signal
1: Pulses equal to $8/f_c$ [s] is regarded as signal

Bit 3 (NREB): Noise rejection enable bit
0: Enable
1: Disable

Bits 2~0 (Protect): Protect bits

Protect	Protect
1	Enable
0	Disable

6.19.2 Code Option Register (Word 1)

6.19.2.1 EM78F644/642/641/544/542/541N Code Option Word 1

Word 1												
Bit 12	Bit 11	Bit 10	Bit 9	Bit 8	Bit 7	Bit 6	Bit 5	Bit 4	Bit 3	Bit 2	Bit 1	Bit 0
COBS0	TCEN	"0"	"1"	C4	C3	C2	C1	C0	RCM1	RCM0	LVR1	LVR0

Bit 12 (COBS0): IRC mode selection bit

0: Select IRC frequency from the code option (default)

1: Select IRC frequency from the register

Bit 11 (TCEN): TCC enable bit

0: P77/TCC is set as P77 (default)

1: P77/TCC is set as TCC

NOTE

The TCEN must be set to "0" in EM78F641/541N

Bit 10: Not used, set to "0" all the time.

Bit 9: Not used, set to "1" all the time.

Bit 8 ~ Bit 4 (C4 ~ C0): Internal RC mode calibration bits.

C4 ~ C0 must be set to "0" only (auto-calibration).

Bit 3 ~ Bit 2 (RCM1 ~ RCM0): RC mode selection bits

RCM 1	RCM 0	Frequency (MHz)
0	0	4 (default)
0	1	16
1	0	8
1	1	455kHz

NOTE

The 455kHz frequency is NOT available in EM78F641/541N

Bit 1 ~ Bit 0 (LVR1 ~ LVR0): Low Voltage Reset Enable bits

LVR1	LVR0	Reset Level	Release Level
0	0	NA	NA
0	1	2.7V	2.9V
1	0	3.5V	3.7V
1	1	4.0V	4.2V

LVR1, LVR0="0, 0": LVR is disabled. The IC power-on reset is 2.0~2.1V (default).

LVR1, LVR0="0, 1": If Vdd < 2.7V, the IC will reset.

LVR1, LVR0="1, 0": If Vdd < 3.5V, the IC will reset.

LVR1, LVR0="1, 1": If Vdd < 4.0V, the IC will reset.

6.19.2.2 EM78F648/548N Code Option Word 1

Word 1														
Bit 14	Bit 13	Bit 12	Bit 11	Bit 10	Bit 9	Bit 8	Bit 7	Bit 6	Bit 5	Bit 4	Bit 3	Bit 2	Bit 1	Bit 0
HLFS	-	SHE	C4	C3	C2	C1	C0	RCM1	RCM0	-	OSC2	OSC1	OSC0	RCOD

Bit 14 (HLFS): Initialize CPU operation mode

0: Normal mode

1: Green mode

Bit 13: Not used, set to “1” all the time.

Bit 12 (SHE): System Halt Enable bit.

0: Disable

1: Enable

Bits 11~7 (C4~C0): IRC trim bits. This part will be auto setup by the writer

Bits 6~5 (RCM1~RCM0): IRC frequency selection bits

RCM 1	RCM 0	Frequency (MHz)
0	0	4 (default)
0	1	16
1	0	8
1	1	455kHz

Bit 4: Not used, set to “1” all the time.

Bits 3~1 (OSC2~OSC0): Oscillator mode selection bits

Mode	OSC2	OSC1	OSC0
XT (XTAL oscillator mode)	0	0	0
HXT (High XTAL oscillator mode)	0	0	1
LXT1 (Low XTAL1 oscillator mode)	0	1	0
LXT2 (Low XTAL2 oscillator mode)	0	1	1
IRC mode, OSC0 (P54) act as I/O pin	1	0	0
IRC mode, OSC0 (P54) act as RCOUT pin	1	0	1
ERC mode, OSC0 (P54) act as I/O pin	1	1	0
ERC mode, OSC0 (P54) act as RCOUT pin	1	1	1

Bit 0 (RCOD): Oscillator output or I/O port selection bit

RCOD	Pin Function
1	OSCO pin is open drain
0	OSCO output system clock (default)

6.19.3 Customer ID Register (Word 2)

6.19.3.1 EM78F644/642/641/544/542/541N Code Option Word 2

Word 2												
Bit 12	Bit 11	Bit 10	Bit 9	Bit 8	Bit 7	Bit 6	Bit 5	Bit 4	Bit 3	Bit 2	Bit 1	Bit 0
SC3	SC2	SC1	SC0	"0"	"1"	"0"	"0"	ID4	ID3	ID2	ID1	ID0

Bits 12 ~ 9 (SC3 ~ SC0): Calibrator of sub frequency (WDT frequency, auto calibration)

Bit 8: Not used, set to "0" all the time.

Bit 7: Not used, set to "1" all the time.

Bits 6 ~ 5: Not used, set to "0" all the time.

Bits 4 ~ 0 (ID4 ~ ID0): Customer's ID code.

6.19.3.2 EM78F648/548N Code Option Word 2

Word 1														
Bit14	Bit13	Bit12	Bit11	Bit10	Bit9	Bit8	Bit7	Bit6	Bit5	Bit4	Bit3	Bit2	Bit1	Bit0
SC3	SC2	SC1	SC0	"0"	"0"	ID8	ID7	ID6	ID5	ID4	ID3	ID2	ID1	ID0

Bits 14 ~ 11 (SC3 ~ SC0): Calibrator of sub frequency (WDT frequency, auto calibration)

Bits 10 ~ 9: Not used, set to "0" all the time.

Bits 8 ~ 0 (ID8 ~ ID0): Customer's ID code.

6.20 Instruction Set

Each instruction in the Instruction Set is a 13-bit word for EM78F664N/F662N/F661N/F564N/F562N/F561N and 15-bit for EM78F648/548N, divided into an OP code and one or more operands. Normally, all instructions are executed within one single instruction cycle (one instruction consists of two oscillator periods), unless the program counter is changed by instructions "MOV R2,A", "ADD R2,A", or by instructions of arithmetic or logic operation on R2 (e.g., "SUB R2,A", "BS(C) R2,6", "CLR R2", ·etc.). Under this condition, the execution takes two instruction cycles.

If for some reasons, the specification of the instruction cycle is not suitable you're your certain applications, try to modify the instruction as follows:

- A) Change one instruction cycle to consist of four oscillator periods.
- B) "LJMP", "LCALL", "TBRD", "RET", "RETL", "RETI", or the conditional skip ("JBS", "JBC", "JZ", "JZA", "DJZ", "DJZA") commands which were tested to be true, are executed within two instruction cycles. The instructions that are written to the program counter also take two instruction cycles.



Case (A) is selected by the Code Option bit called CLK1:0. One instruction cycle consists of two oscillator clocks if CLK1:0 is "01", and four oscillator clocks if CLK1:0 is "00".

Note that once the four oscillator periods within one instruction cycle is selected as in Case (A), the internal clock source to TCC should be CLK = Fosc/4, instead of Fosc/2, as indicated in Figure 6-11 in Section 6.4 *TCC/WDT and Prescaler*.

In addition, the Instruction Set also has the following features:

- 1) Every bit of any register can be set, cleared, or tested directly.
- 2) The I/O register can be regarded as general register. That is, the same instruction can operate on the I/O register.

6.20.1 Instruction Set Table

In the following symbols are used in the Instruction Set table shown below:

"R" represents a register designator that specifies which one of the registers (including operational registers and general purpose registers) is to be utilized by the instruction.

"b" represents a bit field designator that selects the value for the bit which is located in the register "R", and affects operation.

"k" represents an 8 or 10-bit constant or literal value.

■ Instruction Set table

Binary Instruction	Hex	Mnemonic	Operation	Status Affected
0 0000 0000 0000 000 0000 0000 0000	0000	NOP	No Operation	None
0 0000 0000 0001 000 0000 0000 0001	0001	DAA	Decimal Adjust A	C
0 0000 0000 0010	0002	CONTW	A → CONT	None ¹
0 0000 0000 0011 000 0000 0000 0011	0003	SLEP	0 → WDT, Stop oscillator	T, P
0 0000 0000 0100 000 0000 0000 0100	0004	WDTC	0 → WDT	T, P
0 0000 0000 rrrr	000r	IOW R	A → IOCR	None ^{1, 2}
0 0000 0001 0000 000 0000 0001 0000	0010	ENI	Enable Interrupt	None
0 0000 0001 0001 000 0000 0001 0001	0011	DISI	Disable Interrupt	None
0 0000 0001 0010 000 0000 0001 0010	0012	RET	[Top of Stack] → PC	None
0 0000 0001 0011 000 0000 0001 0011	0013	RETI	[Top of Stack] → PC, Enable Interrupt	None

(Continuation)

Binary Instruction	Hex	Mnemonic	Operation	Status Affected
0 0000 0001 0100	0014	CONTR	CONT → A	None ¹
0 0000 0001 rrrr	001r	IOR R	IOCR → A	None ^{1, 2}
0 0000 01rr rrrr 000 0001 rrrr rrrr	00rr 01rr	MOV R,A	A → R	None
0 0000 1000 0000 000 0010 0000 0000	0080 0200	CLRA	0 → A	Z
0 0000 11rr rrrr 000 0011 rrrr rrrr	00rr 03rr	CLR R	0 → R	Z
0 0001 00rr rrrr 000 0100 rrrr rrrr	01rr 04rr	SUB A,R	R-A → A	Z, C, DC
0 0001 01rr rrrr 000 0101 rrrr rrrr	01rr 05rr	SUB R,A	R-A → R	Z, C, DC
0 0001 10rr rrrr 000 0110 rrrr rrrr	01rr 06rr	DECA R	R-1 → A	Z
0 0001 11rr rrrr 000 0111 rrrr rrrr	01rr 07rr	DEC R	R-1 → R	Z
0 0010 00rr rrrr 000 1000 rrrr rrrr	02rr 08rr	OR A,R	A ∨ R → A	Z
0 0010 01rr rrrr 000 1001 rrrr rrrr	02rr 09rr	OR R,A	A ∨ R → R	Z
0 0010 10rr rrrr 000 1010 rrrr rrrr	02rr 0Arr	AND A,R	A & R → A	Z
0 0010 11rr rrrr 000 1011 rrrr rrrr	02rr 0Brr	AND R,A	A & R → R	Z
0 0011 00rr rrrr 000 1100 rrrr rrrr	03rr 0Crr	XOR A,R	A ⊕ R → A	Z
0 0011 01rr rrrr 000 1101 rrrr rrrr	03rr 0Drr	XOR R,A	A ⊕ R → R	Z
0 0011 10rr rrrr 000 1110 rrrr rrrr	03rr 0Err	ADD A,R	A + R → A	Z, C, DC
0 0011 11rr rrrr 000 1111 rrrr rrrr	03rr 0Frr	ADD R,A	A + R → R	Z, C, DC
0 0100 00rr rrrr 001 0000 rrrr rrrr	04rr 10rr	MOV A,R	R → A	Z
0 0100 01rr rrrr 001 0001 rrrr rrrr	04rr 11rr	MOV R,R	R → R	Z
0 0100 10rr rrrr 001 0010 rrrr rrrr	04rr 12rr	COMA R	/R → A	Z
0 0100 11rr rrrr 001 0011 rrrr rrrr	04rr 13rr	COM R	/R → R	Z
0 0101 00rr rrrr 001 0100 rrrr rrrr	05rr 14rr	INCA R	R+1 → A	Z
0 0101 01rr rrrr 001 0101 rrrr rrrr	05rr 15rr	INC R	R+1 → R	Z

(Continuation)

Binary Instruction	Hex	Mnemonic	Operation	Status Affected
0 0101 10rr rrrr 001 0110 rrrr rrrr	05rr 16rr	DJZA R	R-1 → A, skip if zero	None
0 0101 11rr rrrr 001 0111 rrrr rrrr	05rr 17rr	DJZ R	R-1 → R, skip if zero	None
0 0110 00rr rrrr 001 1000 rrrr rrrr	06rr 18rr	RRCA R	R(n) → A(n-1), R(0) → C, C → A(7)	C
0 0110 01rr rrrr 001 1001 rrrr rrrr	06rr 19rr	RRC R	R(n) → R(n-1), R(0) → C, C → R(7)	C
0 0110 10rr rrrr 001 1010 rrrr rrrr	06rr 1Arr	RLCA R	R(n) → A(n+1), R(7) → C, C → A(0)	C
0 0110 11rr rrrr 001 1011 rrrr rrrr	06rr 1Brr	RLC R	R(n) → R(n+1), R(7) → C, C → R(0)	C
0 0111 00rr rrrr 001 1100 rrrr rrrr	07rr 1Crr	SWAPA R	R(0-3) → A(4-7), R(4-7) → A(0-3)	None
0 0111 01rr rrrr 001 1101 rrrr rrrr	07rr 1Drr	SWAP R	R(0-3) ↔ R(4-7)	None
0 0111 10rr rrrr 001 1110 rrrr rrrr	07rr 1Err	JZA R	R+1 → A, skip if zero	None
0 0111 11rr rrrr 001 1111 rrrr rrrr	07rr 1Frr	JZ R	R+1 → R, skip if zero	None
0 100b brrr rrrr 010 0bbb rrrr rrrr	0xxx 2xrr	BC R,b	0 → R(b)	None ³
0 101b brrr rrrr 010 1bbb rrrr rrrr	0xxx 2xrr	BS R,b	1 → R(b)	None ⁴
0 110b brrr rrrr 011 0bbb rrrr rrrr	0xxx 3xrr	JBC R,b	if R(b)=0, skip	None
0 111b brrr rrrr 011 1bbb rrrr rrrr	0xxx 3xrr	JBS R,b	if R(b)=1, skip	None
1 00kk kkkk kkkk 100 kkkk kkkk kkkk	1kkk 4kkk	CALL k	PC+1 → [SP], (Page, k) → PC	None
1 01kk kkkk kkkk 101 kkkk kkkk kkkk	1kkk 5kkk	JMP k	(Page, k) → PC	None
1 1000 kkkk kkkk 110 0000 kkkk kkkk	18kk 60kk	MOV A,k	k → A	None
1 1001 kkkk kkkk 110 0100 kkkk kkkk	19kk 64kk	OR A,k	A ∨ k → A	Z
1 1010 kkkk kkkk 110 1000 kkkk kkkk	1Akk 68kk	AND A,k	A & k → A	Z
1 1011 kkkk kkkk 110 1100 kkkk kkkk	1Bkk 6Ckk	XOR A,k	A ⊕ k → A	Z

(Continuation)

Binary Instruction	Hex	Mnemonic	Operation	Status Affected
1 1100 kkkk kkkk 111 0000 kkkk kkkk	1Ckk 70kk	RETL k	k → A, [Top of Stack] @ PC	None
1 1101 kkkk kkkk 111 0100 kkkk kkkk	1Dkk 74kk	SUB A,k	k-A → A	Z, C, DC
1 1111 kkkk kkkk 111 1100 kkkk kkkk	1Fkk 7Ckk	ADD A,k	k+A → A	Z, C, DC
1 1110 1001 kkkk	1E9k	BANK k	K → R4(7:6)	None ¹
111 1010 1000 kkkk	7A0k	SBANK k	K → R1(4)	None ⁵
111 1010 0100 kkkk	7A4k	GBANK k	K → R1(0)	None ⁵
1 1110 1010 kkkk k kkkk kkkk kkkk 111 1010 1000 kkkk kkk kkkk kkkk kkkk	1EAK kkkk 7A8k kkkk	LCALL k	Next instruction : k kkkk kkkk kkkk PC+1 → [SP], k → PC	None
1 1110 1011 kkkk k kkkk kkkk kkkk 111 1010 1100 kkkk kkk kkkk kkkk kkkk	1EBk kkkk 7ACK kkkk	LJMP k	Next instruction: k kkkk kkkk kkkk k → PC	None
1 1110 11rr rrrr 111 1011 rrrr rrrr	1Err 7Brr	TBRD R	ROM[(TABPTR)] → R	None

¹ This instruction is applicable to EM78F644/642/641/544/542/541N only.

² This instruction is applicable to IOC5~IOC7, IOCA ~ IOCF only.

³ This instruction is not recommended for Interrupt Status Register operation.

⁴ This instruction cannot operate under Interrupt Status Register.

⁵ This instruction is applicable to EM78F648/548N only.

7 Timing Diagram

7.1 AC Test Input/Output Waveform

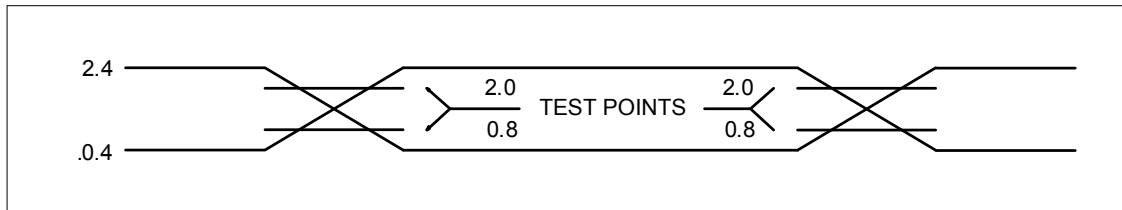

Note: AC Testing: Input are driven at 2.4V for logic "1," and 0.4V for logic "0"
Timing measurements are made at 2.0V for logic "1," and 0.8V for logic "0"

Figure 7-1a AC Test Timing Diagram

7.2 Reset Timing (CLK1:0 = "01")

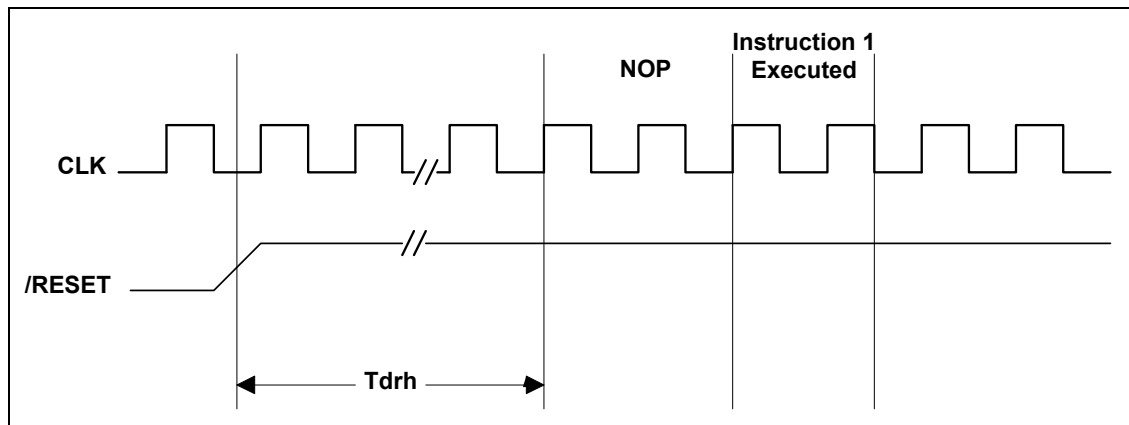

Figure 7-1b Reset Timing Diagram



8 Absolute Maximum Ratings

8.1 For EM78F648/548N

Items	Rating		
Temperature under bias	-40°C	to	85°C
Storage temperature	-65°C	to	150°C
Working voltage	2.3V	to	5.5V
Working frequency	DC	to	16 MHz
Input voltage	V _{ss} -0.3V	to	V _{dd} +0.5V
Output voltage	V _{ss} -0.3V	to	V _{dd} +0.5V

NOTE

These parameters are theoretical values only and have not been tested or verified.

9 DC Electrical Characteristics

9.1 For EM78F648/548N

■ Ta=25°C, VDD=5.0V±5%, VSS=0V

Symbol	Parameter	Condition	Min.	Typ.	Max.	Unit
Fxt	XTAL: VDD to 3V	Two cycles with two clocks	DC	-	8	MHz
	XTAL: VDD to 5V		DC	-	16	MHz
	ERC: VDD to 5V	R: 5.1KΩ, C: 100 pF	F-30%	370	F+30%	kHz
	IRC: VDD to 5V	4 MHz, 1 MHz, 455kHz, 8 MHz	F-2.5%	F	F+2.5%	Hz
IIL	Input Leakage Current for input pins	V _{IN} = VDD, VSS	-	-	±1	μA
IRC1	IRC: VDD to 5V	RCM0:RCM1=1:1	2.9	4	5.7	MHz
IRCE	Internal RC oscillator error per stage	-	±4.3	±4.5	±4.7	%
IRC2	IRC: VDD to 5V	RCM0:RCM1=1:0	5.8	8	11.4	MHz
IRC3	IRC: VDD to 5V	RCM0:RCM1=0:1	0.725	1	1.425	MHz
IRC4	IRC: VDD to 5V	RCM0:RCM1=0:0	330	455	645	kHz
VIHRC	Input High Threshold Voltage (Schmitt trigger)	OSCI in RC mode	3.9	4	4.1	V
IERC1	Sink current	V _I from low to high, V _I =5V	21	22	23	mA
VILRC	Input Low Threshold Voltage (Schmitt trigger)	OSCI in RC mode	1.7	1.8	1.9	V
IERC2	Sink current	V _I from high to low, V _I =2V	16	17	18	mA
IIL	Input Leakage Current for input pins	V _{IN} = VDD, VSS	-1	0	1	μA

(Continuation)

Symbol	Parameter	Condition	Min.	Typ.	Max.	Unit
VIH1	Input High Voltage (Schmitt trigger)	Ports 5, 6, 7, 8, 9	0.7V _{dd}	-	V _{dd} +0.3V	V
VIL1	Input Low Voltage (Schmitt trigger)	Ports 5, 6, 7, 8, 9	-0.3V	-	0.3V _{dd}	V
VIHT1	Input High Threshold Voltage (Schmitt trigger)	/RESET	0.7V _{dd}	-	V _{dd} +0.3V	V
VILT1	Input Low Threshold Voltage (Schmitt trigger)	/RESET	-0.3V	-	0.3V _{dd}	V
VIHT2	Input High Threshold Voltage (Schmitt trigger)	TCC, INT	0.7V _{dd}	-	V _{dd} +0.3V	V
VILT2	Input Low Threshold Voltage (Schmitt trigger)	TCC, INT	-0.3V	-	0.3V _{dd}	V
VIHX1	Clock Input High Voltage	OSCI in crystal mode	2.9	3.0	3.1	V
VILX1	Clock Input Low Voltage	OSCI in crystal mode	1.7	1.8	1.9	V
IOH1	Output High Voltage (Ports 5, 6, 7, 8, 9)	VOH = VDD - 0.5V (IOH =3.7mA)	-4.1	-4.45	-5	mA
IOL1	Output Low Voltage (Ports 5, 6, 7, 8, 9)	VOL = GND+ 0.5V (IOL =10mA)	11	12	13.5	mA
LVR1	Low voltage reset level	Ta= 25°C	2.4	2.7	3.02	V
		Ta= -40~85°C	2.07	2.7	3.37	V
LVR2	Low voltage reset level	Ta= 25°C	3.29	3.7	4.18	V
		Ta= -40~85°C	2.78	3.7	4.66	V
LVR3	Low voltage reset level	Ta= 25°C	3.71	4.2	4.71	V
		Ta= -40~85°C	3.18	4.2	5.26	V
IPH	Pull-high current	Pull-high active, Input pin at VSS	-70	-75	-80	μA
IPL	Pull-low current	Pull-low active, Input pin at V _{dd}	35	40	45	μA
ISB1	Power down current	All input and I/O pins at VDD Output pin floating, WDT disabled	0.6	2.0	2.5	μA
ISB2	Power down current	All input and I/O pins at VDD, Output pin floating, WDT enabled	6	7	8	μA
ICC1	Operating supply current for two clocks	/RESET= 'High', Fosc=32kHz (Crystal type,CLKS="0"), Output pin floating, WDT disabled	20	22	24	μA
ICC2	Operating supply current for two clocks	/RESET= 'High', Fosc=32kHz (Crystal type,CLKS="0"), Output pin floating, WDT enabled	25	27	29	μA
ICC3	Operating supply current for two clocks	/RESET= 'High', Fosc=4 MHz (Crystal type, CLKs="0"), Output pin floating, WDT enabled	1.5	1.6	1.7	mA
ICC4	Operating supply current for two clocks	/RESET= 'High', Fosc=10 MHz (Crystal type, CLKs="0"), Output pin floating, WDT enabled	2.1	2.2	2.3	mA

NOTE

- The parameters shown above are theoretical values only and have not been tested or verified.
- Data under “Min”, “Typ”, and “Max” columns are based on theoretical results at 25°C.
These data are for design reference only and have not been tested or verified.

9.1.1 Program Flash Memory Electrical Characteristics

Symbol	Parameter	Condition	Min.	Typ.	Max.	Unit
Tprog	Erase/Write cycle time	Vdd = 5.0V Temperature = -40°C ~ 85°C	-	-	-	ms
Treten	Data Retention		-	10	-	years
Tendu	Endurance time		-	100K	-	cycles

9.1.2 Data EEPROM Electrical Characteristics (for EM78F648N only)

Symbol	Parameter	Condition	Min.	Typ.	Max.	Unit
Tprog	Erase/Write cycle time	Vdd = 2.0~ 5.5V Temperature = -40°C ~ 85°C	-	6	-	ms
Treten	Data Retention		-	10	-	years
Tendu	Endurance time		-	1000K	-	cycles

9.1.3 Comparator Electrical Characteristics

Symbol	Parameter	Condition	Min.	Typ.	Max.	Unit
VOS	Input offset voltage ¹	RL = 5.1K	-	-	10	mV
Vcm	Input common-mode voltage range ²	-	GND	-	VDD	V
ICO	Supply current of Comparator	-	-	300	-	uA
TRS	Response time ³	Vin(-)=2.5V, Vdd=5V, CL=15p (comparator output load), Overdrive = 30mV	-	0.8	-	us
VS	Operating range	-	2.5	-	5.5	V

¹ The output voltage is in the unit gain circuitry and over the full input common-mode range.

² The input common-mode voltage or either input signal voltage should not be allowed to go negative by more than 0.3V. The upper end of the common-mode voltage range is VDD.

³ The response time specified is a 100 mV input step with 30 mV overdrive.

9.2 For EM78F644/544N

■ Ta=25°C, VDD=5.0V ± 5%, VSS=0V

Symbol	Parameter	Condition	Min.	Typ.	Max.	Unit
Fxt	Crystal: VDD to 3V	Two cycles with two clocks	DC	–	8	MHz
	Crystal: VDD to 5V		DC	–	16	MHz
	ERC: VDD to 5V	R: 5.1KΩ, C: 300 pF	F-30%	370	F+30%	kHz
	IRC: VDD to 5V	4 MHz, 16 MHz, 8 MHz, 455kHz	F-2.5%	F	F+2.5%	Hz
IIL	Input Leakage Current for Input pins	VIN = VDD, VSS	–	–	±1	μA
VIHRC	Input High Threshold Voltage (Schmitt Trigger)	OSCI in RC mode	–	3.5	–	V
IERC1	Sink current	VI from low to high, VI=5V	21	22	23	mA
VILRC	Input Low Threshold Voltage (Schmitt Trigger)	OSCI in RC mode	–	1.5	–	V
IERC2	Sink current	VI from high to low, VI=2V	16	17	18	mA
VIH1	Input High Voltage (Schmitt Trigger)	Ports 5, 6, 7, 8	0.7VDD	–	VDD+0.3V	V
VIL1	Input Low Voltage (Schmitt Trigger)	Ports 5, 6, 7, 8	-0.3V	–	0.3VDD	V
VIHT1	Input High Threshold Voltage (Schmitt Trigger)	/RESET	0.7VDD	–	VDD+0.3V	V
VILT1	Input Low Threshold Voltage (Schmitt Trigger)	/RESET	-0.3V	–	0.3VDD	V
VIHT2	Input High Threshold Voltage (Schmitt Trigger)	TCC, INT	0.7VDD	–	VDD+0.3V	V
VILT2	Input Low Threshold Voltage (Schmitt Trigger)	TCC, INT	-0.3V	–	0.3VDD	V
VIHX1	Clock Input High Voltage	OSCI in crystal mode	–	3.0	–	V
VILX1	Clock Input Low Voltage	OSCI in crystal mode	–	1.8	–	V
IOH1	Output High Voltage (Ports 5~8)	VOH = VDD-0.5V (IOH =3.7mA)	-3.3	-4.2	–	mA
IOL1	Output Low Voltage (Ports 5, 7, 8)	VOL = GND+0.5V	9	11	–	mA
IOL2	Output Low Voltage (Port 6)	VOL = GND+0.5V	14	18	–	mA
LVR1	Low voltage reset level	Ta= 25°C	2.4	2.7	3.02	V
		Ta= -40~85°C	2.07	2.7	3.37	V
LVR2	Low voltage reset level	Ta= 25°C	3.09	3.5	3.98	V
		Ta= -40~85°C	2.58	3.5	4.46	V
LVR3	Low voltage reset level	Ta= 25°C	3.51	4.0	4.51	V
		Ta= -40~85°C	2.98	4.0	5.06	V



(Continuation)

Symbol	Parameter	Condition	Min.	Typ.	Max.	Unit
IPH	Pull-high current	Pull-high active, Input pin at VSS	–	-70	-80	μA
IPL	Pull-low current	Pull-low active, Input pin at Vdd	–	20	30	μA
ISB1	Power down current	All input and I/O pins at VDD, Output pin floating, WDT disabled	–	1.0	1.5	μA
ISB2	Power down current	All input and I/O pins at VDD, Output pin floating, WDT enabled	–	8	10	μA
ICC1	Operating supply current for two clocks	/RESET= 'High', Fosc=32kHz (Crystal type, LKS1:0="01"), Output pin floating, WDT disabled	–	39	42	μA
ICC2	Operating supply current for two clocks	/RESET= 'High', Fosc=32kHz (Crystal type, LKS1:0="01"), Output pin floating, WDT enabled	–	39	42	μA
ICC3	Operating supply current at two clocks	/RESET= 'High', Fosc=455kHz (Crystal type, CLKS1:0="01"), Output pin floating, WDT enabled (*VDD = 3V)	–	110	120	μA
ICC4	Operating supply current for two clocks	/RESET = 'High', Fosc=455kHz (IRC type, CLKS1:0="01"), Output pin floating, WDT enabled (*VDD = 3V)	–	100	110	μA
ICC5	Operating supply current for two clocks	/RESET = 'High', Fosc = 4 MHz (Crystal type, CLKS1:0 = "01"), Output pin floating, WDT enabled	–	1.1	1.5	mA
ICC6	Operating supply current for two clocks	/RESET = 'High', Fosc = 10 MHz (Crystal type, CLKS1:0 = "01"), Output pin floating, WDT enabled	–	2.6	3	mA

NOTE

- The parameters shown above are theoretical values only and have not been tested or verified.
- Data under "Min", "Typ", and "Max" columns are based on theoretical results at 25°C.
These data are for design reference only and have not been tested or verified.

9.2.1 Program Flash Memory Electrical Characteristics

Symbol	Parameter	Condition	Min.	Typ.	Max.	Unit
Tprog	Erase/Write cycle time	Vdd = 5.0V Temperature = -40°C ~ 85°C	-	-	-	ms
Treten	Data Retention		-	10	-	years
Tendu	Endurance time		-	100K	-	cycles

9.2.2 Data EEPROM Electrical Characteristics (for EM78F644N only)

Symbol	Parameter	Condition	Min.	Typ.	Max.	Unit
Tprog	Erase/Write cycle time	Vdd = 2.5~ 5.5V Temperature = -40°C ~ 85°C	-	4.5	-	ms
Treten	Data Retention		-	10	-	years
Tendu	Endurance time		-	1000K	-	cycles

9.2.3 Comparator Electrical Characteristics

Symbol	Parameter	Condition	Min.	Typ.	Max.	Unit
VOS	Input offset voltage ¹	RL = 5.1K	-	-	10	mV
Vcm	Input common-mode voltage range ²	-	GND	-	VDD	V
ICO	Supply current of Comparator	-	-	200	-	uA
TRS	Response time ³	Vin(-)=2.5V, Vdd=5V, CL=15p (comparator output load), Overdrive = 30mV	-	0.7	-	us
TLRS	Large signal response time	Vin(-)=2.5V, Vdd=5V, CL=15p (comparator output load)	-	300	-	ns
VS	Operating range	-	2.5	-	5.5	V

¹ The output voltage is in the unit gain circuitry and over the full input common-mode range.

² The input common-mode voltage or either input signal voltage should not be allowed to go negative by more than 0.3V. The upper end of the common-mode voltage range is VDD.

³ The response time specified is a 100 mV input step with 30 mV overdrive.



9.3 EM78F642/542N

■ Ta=25°C, VDD = 5.0V ± 5%, VSS = 0V

Symbol	Parameter	Condition	Min.	Typ.	Max.	Unit
Fxt	Crystal: VDD to 3V	Two cycles with two clocks	DC	–	8	MHz
	Crystal: VDD to 4.5V		DC	–	16	MHz
	ERC: VDD to 5V	R: 5.1KΩ, C: 300 pF	F-30%	370	F+30%	kHz
	IRC: VDD to 5V	4 MHz, 16 MHz, 8 MHz, 455kHz	F-2.5%	F	F+2.5%	Hz
IIL	Input Leakage Current for Input pins	VIN = VDD, VSS	–	–	±1	μA
VIHRC	Input High Threshold Voltage (Schmitt Trigger)	OSCI in RC mode	–	3.5	–	V
IERC1	Sink current	VI from low to high, VI=5V	21	22	23	mA
VILRC	Input Low Threshold Voltage (Schmitt Trigger)	OSCI in RC mode	–	1.5	–	V
IERC2	Sink current	VI from high to low, VI=2V	16	17	18	mA
VIH1	Input High Voltage (Schmitt Trigger)	Ports 5, 6, 7, 8	0.7VDD	–	VDD+0.3V	V
VIL1	Input Low Voltage (Schmitt Trigger)	Ports 5, 6, 7, 8	-0.3V	–	0.3VDD	V
VIHT1	Input High Threshold Voltage (Schmitt Trigger)	/RESET	0.7VDD	–	VDD+0.3V	V
VILT1	Input Low Threshold Voltage (Schmitt Trigger)	/RESET	-0.3V	–	0.3VDD	V
VIHT2	Input High Threshold Voltage (Schmitt Trigger)	TCC, INT	0.7VDD	–	VDD+0.3V	V
VILT2	Input Low Threshold Voltage (Schmitt Trigger)	TCC, INT	-0.3V	–	0.3VDD	V
VIHX1	Clock Input High Voltage	OSCI in crystal mode	–	3.0	–	V
VILX1	Clock Input Low Voltage	OSCI in crystal mode	–	1.8	–	V
IOH1	Output High Voltage (Ports 5, 6, 7, 8)	VOH = VDD-0.5V (IOH =3.7mA)	-3.0	-4.2	–	mA
IOL1	Output Low Voltage (Ports 5, 7, 8)	VOL = GND+0.5V	14	18	–	mA
IOL2	Output Low Voltage (Port 6)	VOL = GND+0.5V	18	23	–	mA
LVR1	Low voltage reset level	Ta= 25°C	2.4	2.7	3.02	V
		Ta= -40~85°C	2.07	2.7	3.37	V
LVR2	Low voltage reset level	Ta= 25°C	3.09	3.5	3.98	V
		Ta= -40~85°C	2.58	3.5	4.46	V
LVR3	Low voltage reset level	Ta= 25°C	3.51	4.0	4.51	V
		Ta= -40~85°C	2.98	4.0	5.06	V
IPH	Pull-high current	Pull-high active, Input pin at VSS	–	-70	-80	μA
IPL	Pull-low current	Pull-low active, Input pin at Vdd	–	20	30	μA

(Continuation)

Symbol	Parameter	Condition	Min.	Typ.	Max.	Unit
ISB1	Power down current	All input and I/O pins at VDD, Output pin floating, WDT disabled	–	1.0	1.5	μA
ISB2	Power down current	All input and I/O pins at VDD, Output pin floating, WDT enabled	–	8	10	μA
ICC1	Operating supply current for two clocks	/RESET= 'High', Fosc=32kHz (Crystal type, LKS1:0="01"), Output pin floating, WDT disabled	–	37	40	μA
ICC2	Operating supply current for two clocks	/RESET= 'High', Fosc=32kHz (Crystal type, CLKS1:0="01"), Output pin floating, WDT enabled	–	39	43	μA
ICC3	Operating supply current for two clocks	/RESET= 'High', Fosc=455kHz (Crystal type, CLKS1:0="01"), Output pin floating, WDT enabled (VDD = 3V)	–	110	120	μA
ICC4	Operating supply current for two clocks	/RESET = 'High', Fosc=455kHz (IRC type, CLKS1:0="01"), Output pin floating, WDT enabled (VDD = 3V)	–	100	110	μA
ICC5	Operating supply current for two clocks	/RESET = 'High', Fosc = 4 MHz (Crystal type, CLKS1:0 = "01"), Output pin floating, WDT enabled	–	1.1	1.5	mA
ICC6	Operating supply current for two clocks	/RESET = 'High', Fosc = 10 MHz (Crystal type, CLKS1:0 = "01"), Output pin floating, WDT enabled	–	2.8	3	mA

NOTE

- The parameters shown above are theoretical values only and have not been tested or verified.
- Data under "Min.", "Typ.", and "Max." columns are based on theoretical results at 25°C.
These data are for design guidance only and have not been tested or verified.

9.3.1 Program Flash Memory Electrical Characteristics

Symbol	Parameter	Condition	Min.	Typ.	Max.	Unit
Tprog	Erase/Write cycle time	Vdd = 5.0V Temperature = -40°C ~ 85°C	–	–	–	ms
Treten	Data Retention		–	10	–	years
Tendu	Endurance time		–	100K	–	cycles

9.3.2 Data EEPROM Electrical Characteristics (for EM78F642N only)

Symbol	Parameter	Condition	Min.	Typ.	Max.	Unit
Tprog	Erase/Write cycle time	Vdd = 2.5 ~ 5.5V Temperature = -40°C ~ 85°C	–	4.5	–	ms
Treten	Data Retention		–	10	–	years
Tendu	Endurance time		–	1000K	–	cycles

9.3.3 Comparator Electrical Characteristics

Symbol	Parameter	Condition	Min.	Typ.	Max.	Unit
VOS	Input offset voltage ¹	RL = 5.1K	–	–	5	mV
Vcm	Input common-mode voltages range ²	–	GND	–	VDD	V
ICO	Supply current of Comparator	–	–	200	–	uA
TRS	Response time ³	Vin(-)=2.5V, Vdd=5V, CL=15p (comparator output load), Overdrive = 30mV	–	0.7	–	us
TLRS	Large signal response time	Vin(-)=2.5V, Vdd=5V, CL=15p (comparator output load)	–	260	–	ns
VS	Operating range	–	2.5	–	5.5	V

¹ The output voltage is in the unit gain circuitry and over the full input common-mode range.

² The input common-mode voltage or either input signal voltage should not be allowed to go negative by more than 0.3V. The upper end of the common-mode voltage range is VDD.

³ The response time specified is a 100 mV input step with 30 mV overdrive.

9.4 EM78F641/541N

■ Ta=25°C, VDD=5.0V±5%, VSS=0V

Symbol	Parameter	Condition	Min.	Typ.	Max.	Unit
Fxt	Crystal: VDD to 3V	Two cycles with two clocks	DC	–	8	MHz
	Crystal: VDD to 5V		DC	–	16	MHz
	ERC: VDD to 5V	R: 5.1KΩ, C: 300 pF	F-30%	370	F+30%	kHz
	IRC: VDD to 5V	4 MHz, 16 MHz, 8 MHz	F-2.5%	F	F+2.5%	Hz
IIL	Input Leakage Current for input pins	VIN = VDD, VSS	–	–	±1	μA
VIHRC	Input High Threshold Voltage (Schmitt Trigger)	OSCI in RC mode	–	3.5	–	V
IERC1	Sink current	VI from low to high, VI=5V	21	22	23	mA
VILRC	Input Low Threshold Voltage (Schmitt Trigger)	OSCI in RC mode	–	1.5	–	V
IERC2	Sink current	VI from high to low, VI=2V	16	17	18	mA
VIH1	Input High Voltage (Schmitt Trigger)	Ports 5, 6, 8	0.7VDD	–	VDD+0.3V	V
VIL1	Input Low Voltage (Schmitt Trigger)	Ports 5, 6, 8	-0.3V	–	0.3 VDD	V
VIHT1	Input High Threshold Voltage (Schmitt Trigger)	/RESET	0.7VDD	–	VDD+0.3V	V
VILT1	Input Low Threshold Voltage (Schmitt Trigger)	/RESET	-0.3V	–	0.3 VDD	V
VIHT2	Input High Threshold Voltage (Schmitt Trigger)	INT	0.7VDD	–	VDD+0.3V	V
VILT2	Input Low Threshold Voltage (Schmitt Trigger)	INT	-0.3V	–	0.3 VDD	V
VIHX1	Clock Input High Voltage	OSCI in crystal mode	–	3.0	–	V
VILX1	Clock Input Low Voltage	OSCI in crystal mode	–	1.8	–	V
IOH1	Output High Voltage (Ports 5, 6, 8)	VOH = VDD-0.5V (IOH =3.7mA)	-3.0	-4.2	–	mA
IOL1	Output Low Voltage (Ports 5, 8)	VOL = GND+0.5V	9	11	–	mA
IOL2	Output Low Voltage (Port 6)	VOL = GND+0.5V	15	18	–	mA
LVR1	Low voltage reset level	Ta= 25°C	2.4	2.7	3.02	V
		Ta= -40~85°C	2.07	2.7	3.37	V
LVR2	Low voltage reset level	Ta= 25°C	3.09	3.5	3.98	V
LVR3	Low voltage reset level	Ta= 25°C	3.51	4.0	4.51	V
		Ta= -40~85°C	2.98	4.0	5.06	V
IPH	Pull-high current	Pull-high active, Input pin at VSS	–	-70	-80	μA
IPL	Pull-low current	Pull-low active, Input pin at Vdd	–	20	30	μA



(Continuation)

Symbol	Parameter	Condition	Min.	Typ.	Max.	Unit
ISB1	Power down current	All input and I/O pins at VDD, Output pin floating, WDT disabled	–	1.0	1.5	μA
ISB2	Power down current	All input and I/O pins at VDD, Output pin floating, WDT enabled	–	8	10	μA
ICC1	Operating supply current for two clocks	/RESET= 'High', Fosc=32kHz (Crystal type, CLKS1:0="01"), Output pin floating, WDT disabled, HLP=1	–	37	40	μA
ICC2	Operating supply current for two clocks	/RESET= 'High', Fosc=32kHz (Crystal type, CLKS1:0="01"), Output pin floating, WDT enabled, HLP=1	–	39	43	μA
ICC3	Operating supply current for two clocks	/RESET= 'High', Fosc=455kHz (Crystal type, CLKS1:0="01"), Output pin floating, WDT enabled, HLP=1 (VDD = 3V)	–	110	120	μA
ICC4	Operating supply current for two clocks	/RESET = 'High', Fosc=4 MHz (Crystal type, CLKS1:0 = "01"), Output pin floating, WDT enabled	–	1.1	1.5	mA
ICC5	Operating supply current for two clocks	/RESET = 'High', Fosc=10 MHz (Crystal type, CLKS1:0 = "01"), Output pin floating, WDT enabled	–	2.7	3	mA

NOTE

- The parameters shown above are theoretical values only and have not been tested or verified.
- Data under "Min.", "Typ.", and "Max." columns are based on theoretical results at 25°C.
These data are for design reference only and have not been tested or verified.

9.4.1 Program Flash Memory Electrical Characteristics

Symbol	Parameter	Condition	Min.	Typ.	Max.	Unit
Tprog	Erase/Write cycle time	Vdd = 5.0V Temperature = -40°C ~ 85°C	-	-	-	ms
Treten	Data Retention		-	10	-	years
Tendu	Endurance time		-	100K	-	cycles

9.4.2 Data EEPROM Electrical Characteristics (for EM78F641N only)

Symbol	Parameter	Condition	Min.	Typ.	Max.	Unit
Tprog	Erase/Write cycle time	Vdd = 2.5~ 5.5V Temperature = -40°C ~ 85°C	-	4.5	-	ms
Treten	Data Retention		-	10	-	years
Tendu	Endurance time		-	1000K	-	cycles

9.4.3 Comparator Electrical Characteristics

Symbol	Parameter	Condition	Min.	Typ.	Max.	Unit
VOS	Input offset voltage ¹	RL = 5.1K	-	-	5	mV
Vcm	Input common-mode voltages range ²	-	GND	-	VDD	V
ICO	Supply current of Comparator	-	-	200	-	μA
TRS	Response time ³	Vin(-)=2.5V, Vdd=5V, CL=15p (comparator output load), Overdrive = 30mV	-	0.7	-	μs
TLRS	Large signal response time	Vin(-)=2.5V, Vdd=5V, CL=15p (comparator output load)	-	260	-	ns
VS	Operating range	-	2.5	-	5.5	V

¹ The output voltage is in the unit gain circuitry and over the full input common-mode range.

² The input common-mode voltage or either input signal voltage should not be allowed to go negative by more than 0.3V. The upper end of the common-mode voltage range is VDD.

³ The response time specified is a 100 mV input step with 30 mV overdrive.

10 AC Electrical Characteristics

NOTE

- The parameters shown below are theoretical values only and have not been tested or verified.
- Data under "Min.", "Typ.", and "Max." columns are based on theoretical results at 25°C.
These data are for design guidance only and have not been tested or verified.

10.1 EM78F648/548N

■ $-40 \leq T_a \leq 85^\circ\text{C}$, VDD=5V, VSS=0V

Symbol	Parameter	Conditions	Min.	Typ.	Max.	Unit
Dclk	Input CLK duty cycle	–	45	50	55	%
Tins	Instruction cycle time (CLKS1:0="01")	Crystal type	100	–	DC	ns
		RC type	500	–	DC	ns
Ttcc	TCC input period	–	(Tins+20)/N*	–	–	ns
Tdrh	Device reset hold time	–	11.8	16.8	21.8	ms
Trst	/RESET pulse width	Ta = 25°C	100	–	–	ns
Twdt	Watchdog timer period	Ta = 25°C	11.8	16.8	21.8	ms
Tset	Input pin setup time	–	–	0	–	ns
Thold	Input pin hold time	–	–	20	–	ns
Tdelay	Output pin delay time	Cload = 20 pF	–	50	–	ns

* N: Selected prescaler ratio

10.2 EM78F644/642/641/544/542/541N

■ $-40 \leq T_a \leq 85^\circ\text{C}$, VDD=5V, VSS=0V

Symbol	Parameter	Conditions	Min.	Typ.	Max.	Unit
Dclk	Input CLK duty cycle	–	45	50	55	%
Tins	Instruction cycle time (CLKS1:0="01")	Crystal type	100	–	DC	ns
		RC type	500	–	DC	ns
Ttcc	TCC input period	–	(Tins+20)/N*	–	–	ns
Tdrh	Device reset hold time	–	14	16	18	ms
Trst	/RESET pulse width	Ta = 25°C	2000	–	–	ns
Twdt	Watchdog timer period	Ta = 25°C	14	16	18	ms
Tset	Input pin setup time	–	–	0	–	ns
Thold	Input pin hold time	–	–	20	–	ns
Tdelay	Output pin delay time	Cload = 20 pF	–	50	–	ns

* N: Selected prescaler ratio

APPENDIX

A Package Type

Flash MCU	Package Type	Pin Count	Package Size
EM78F648/548NQ44J/S	QFP	44	10mm x 10mm
EM78F648/548ND40J/S	DIP	40	600 mil
EM78F648/548NK28J/S	Skinny DIP	28	300 mil
EM78F648/548ND28J/S	DIP	28	600 mil
EM78F648/548NSO28J/S	SOP	28	300 mil
EM78F644/544NK28J/S	Skinny DIP	28	300 mil
EM78F644/544NSO28J/S	SOP	28	300 mil
EM78F644/544NK24J/S	Skinny DIP	24	300 mil
EM78F644/544NSO24J/S	SOP	24	300 mil
EM78F642/542ND20J/S	DIP	20	300 mil
EM78F642/542NSO20J/S	SOP	20	300 mil
EM78F642/542NSS20J/S	SSOP	20	209mil
EM78F642/542ND18J/S	DIP	18	300 mil
EM78F642/542NSO18J/S	SOP	18	300 mil
EM78F641/541NAD16J/S	DIP	16	300 mil
EM78F641/541NASO16AJ/S	SOP	16	150 mil
EM78F641/541NMS10J/S	MSOP	10	118 mil

A.1 Green Products Compliance

These MCUs are Green products which do not contain hazardous substances. They complied with the third edition of Sony SS-00259 standard.

The Pb contents are less the 100 ppm and complied with Sony specifications.

Part No.	EM78F64x/54xNxJ/xS
Electroplate type	Pure Tin
Ingredient (%)	Sn: 100%
Melting point (°C)	232°C
Electrical resistivity ($\mu\Omega$ cm)	11.4
Hardness (hv)	8~10
Elongation (%)	>50%

B Packaging Configuration

B.1 EM78F648/548N

B.1.1 44-Pin QFP Package

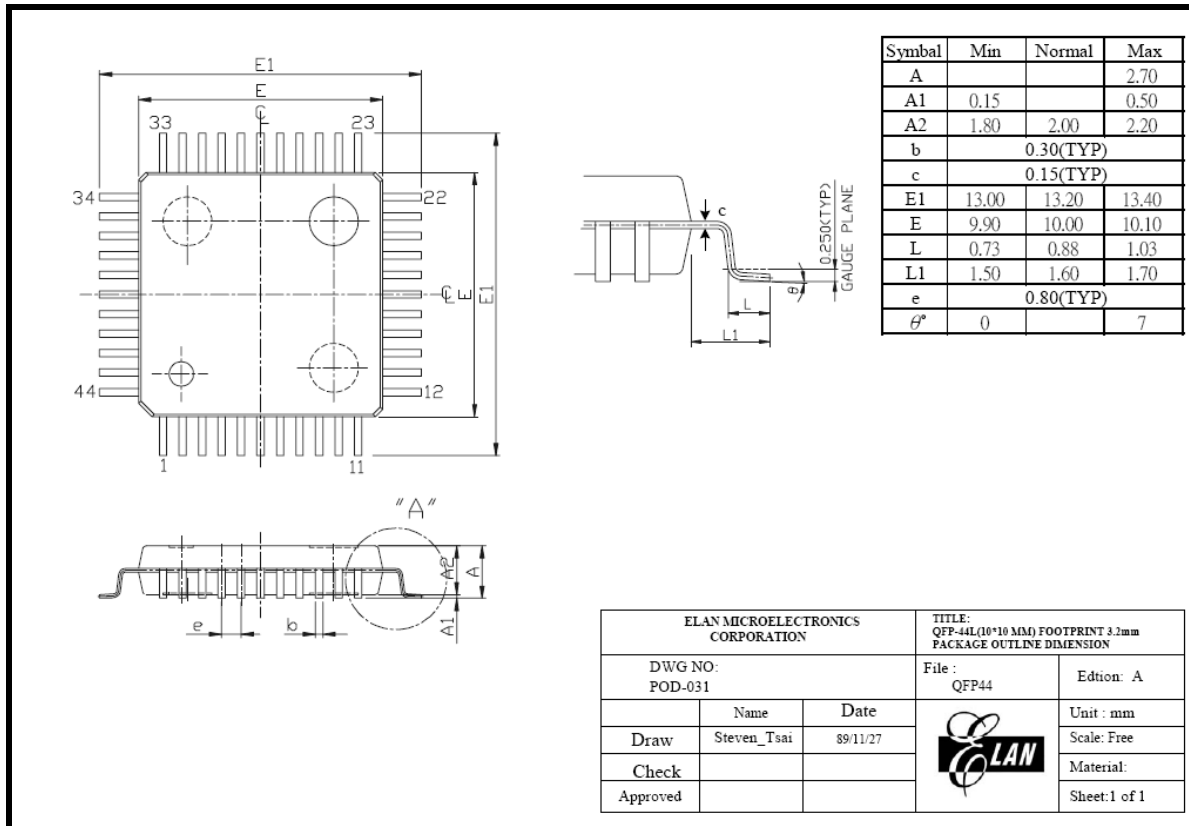

Figure B-1 EM78F648/548N 44-Pin QFP Package Type

B.1.2 40-Pin DIP Package

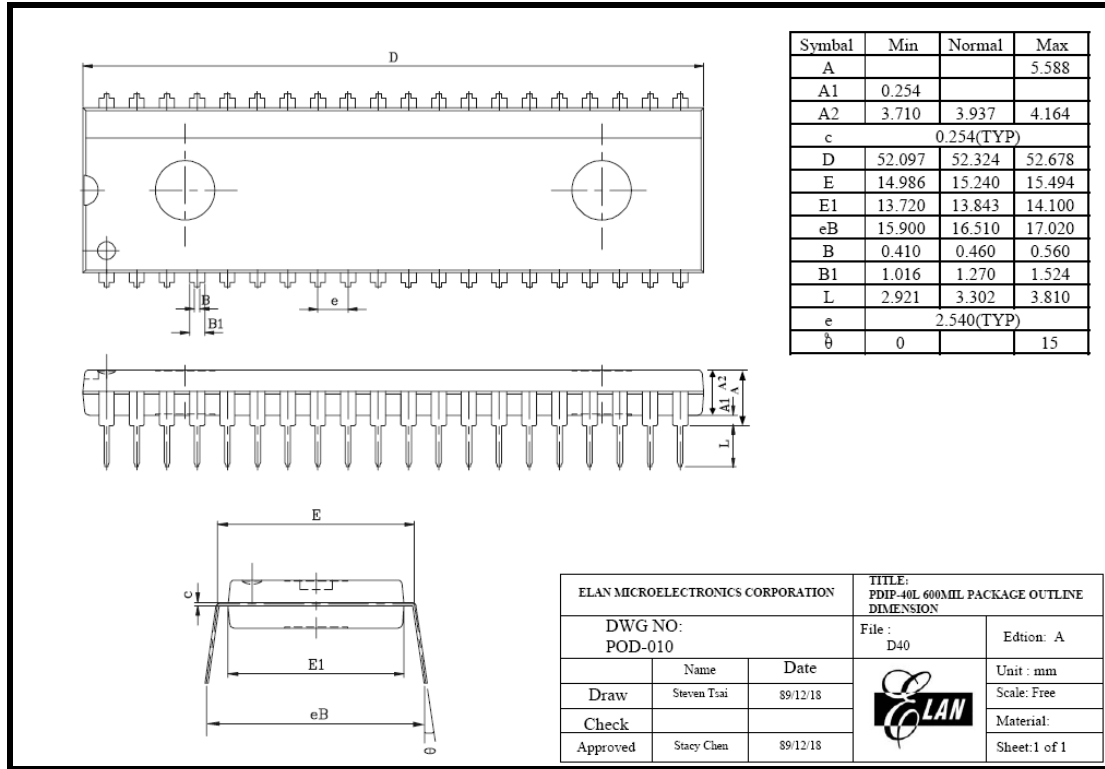

Figure B-2 EM78F648/548N 40-Pin DIP Package Type

B.1.3 28-Pin Skinny DIP Package

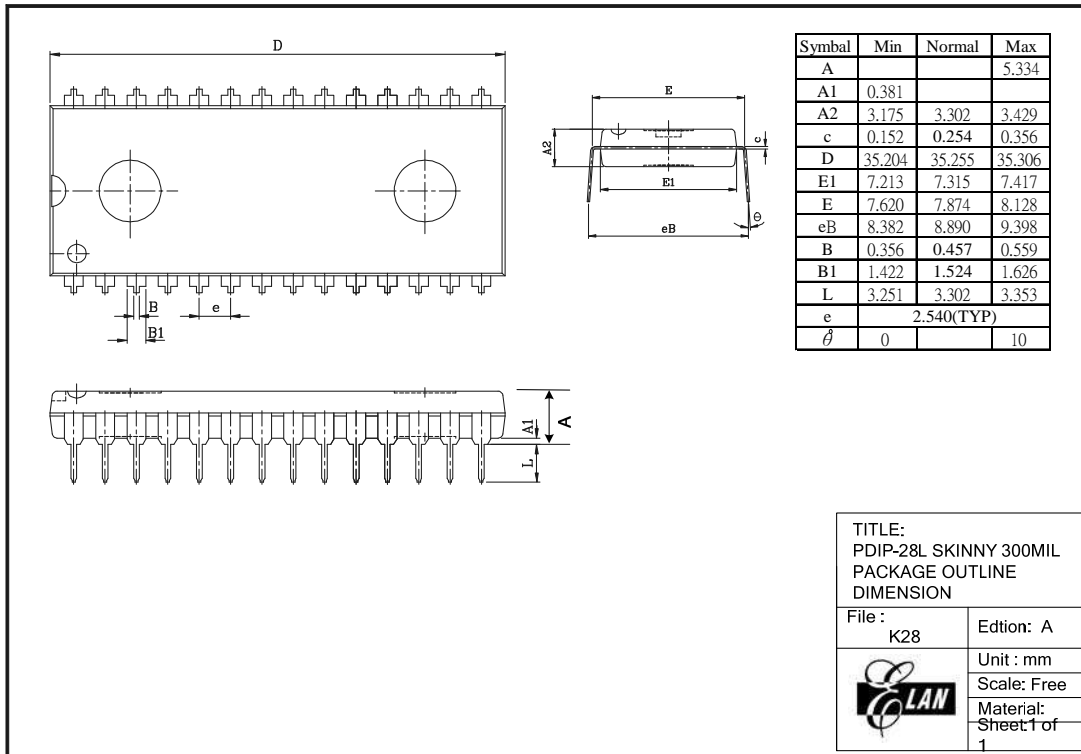

Figure B-3 EM78F648/548N 28-Pin Skinny DIP Package Type

B.1.4 28-Pin DIP Package

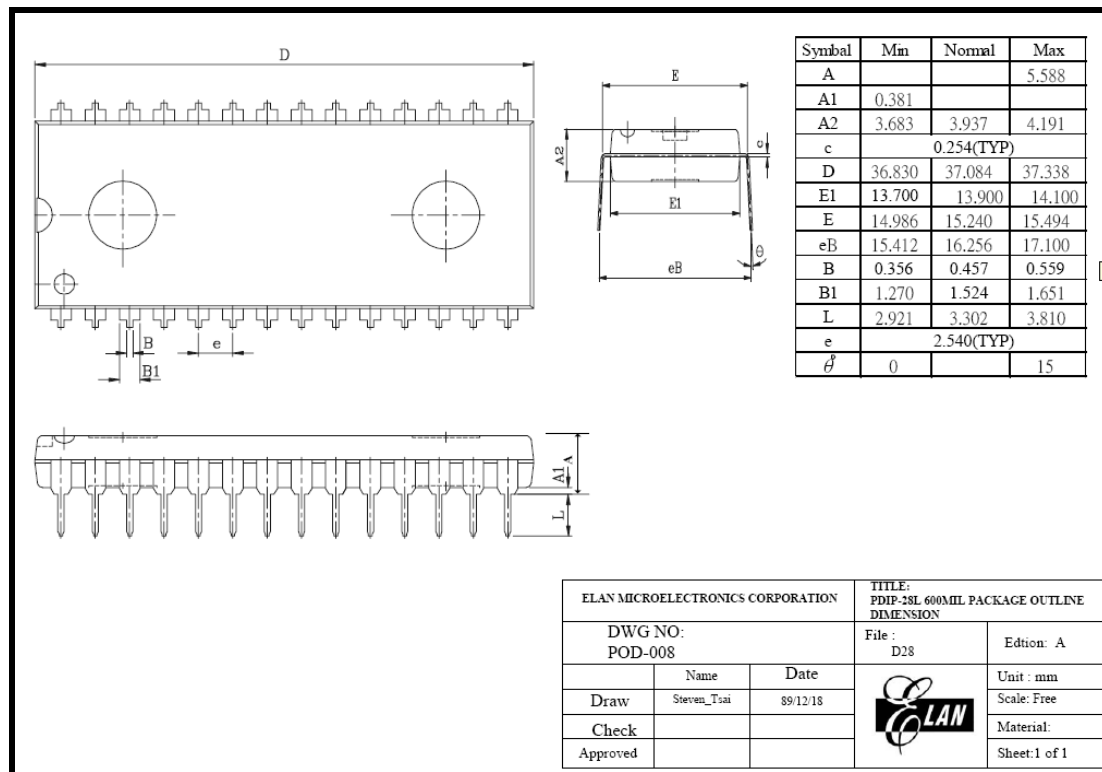

Figure B-4 EM78F648/548N 28-Pin DIP Package Type

B.1.5 28-Pin SOP Package

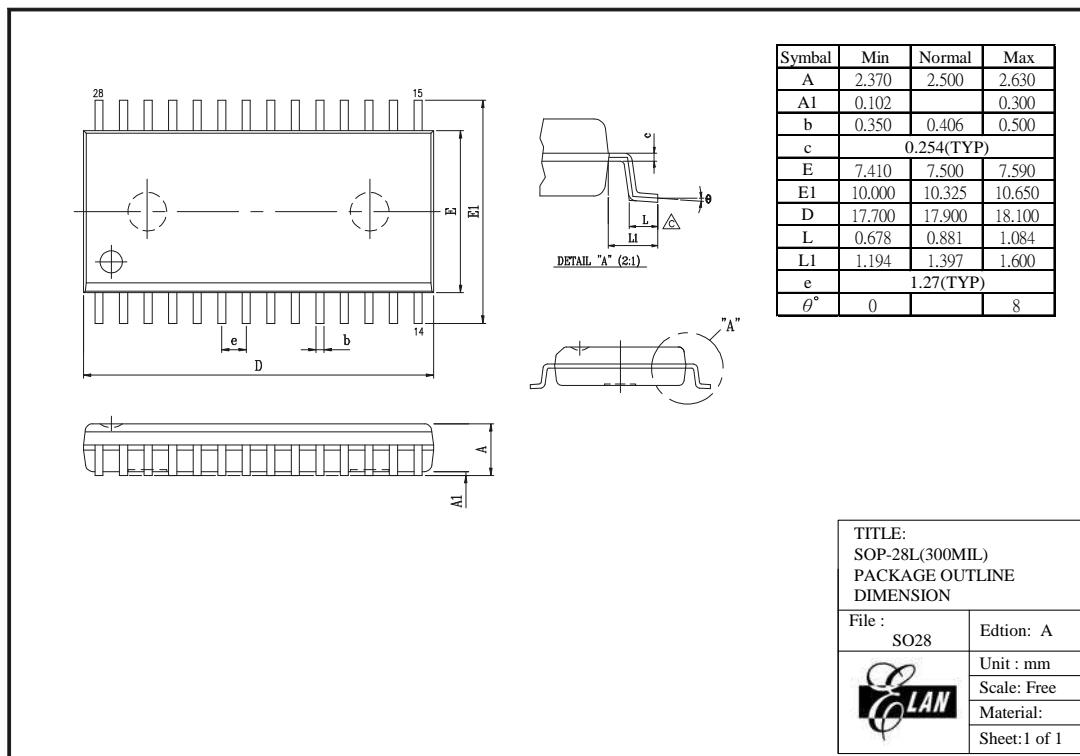

Figure B-5 EM78F648/548N 28-Pin SOP Package Type

B.2 EM78F644/544N

B.2.1 28-Pin Skinny DIP Package

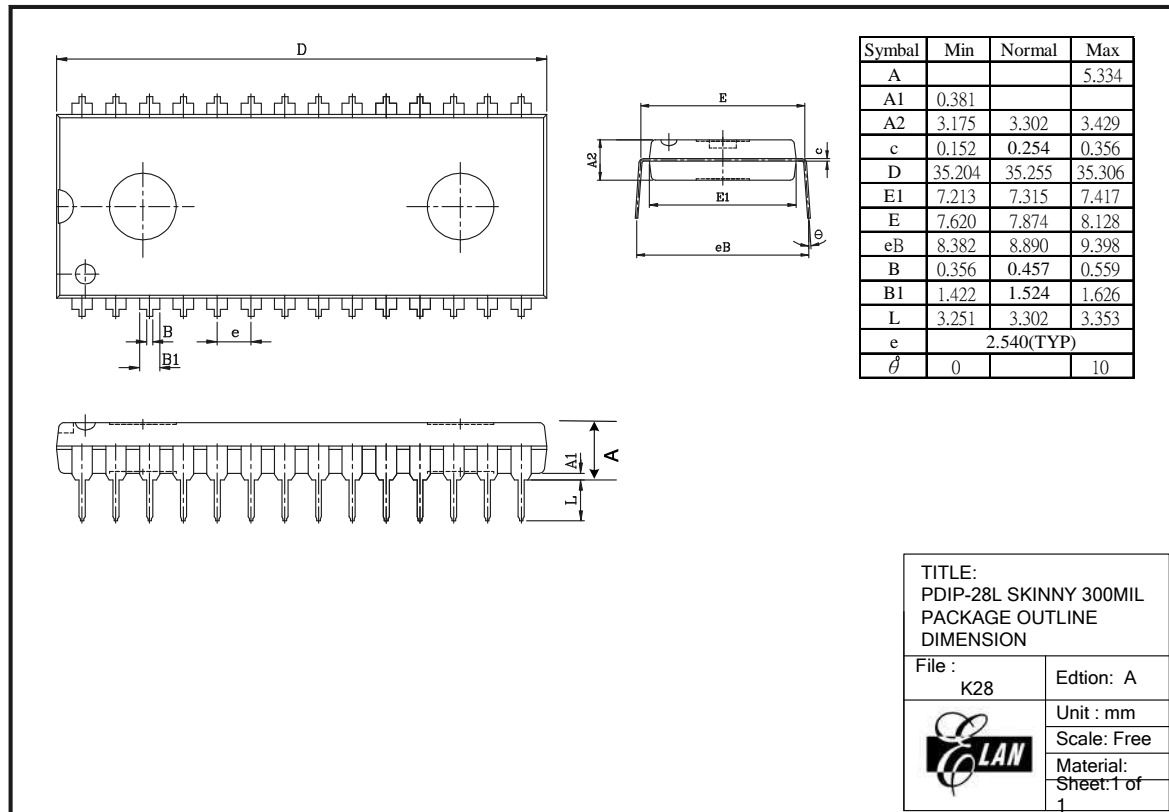

Figure B-6 EM78F644/544N 28-pin Skinny DIP Package Type

B.2.2 28-Pin SOP Package

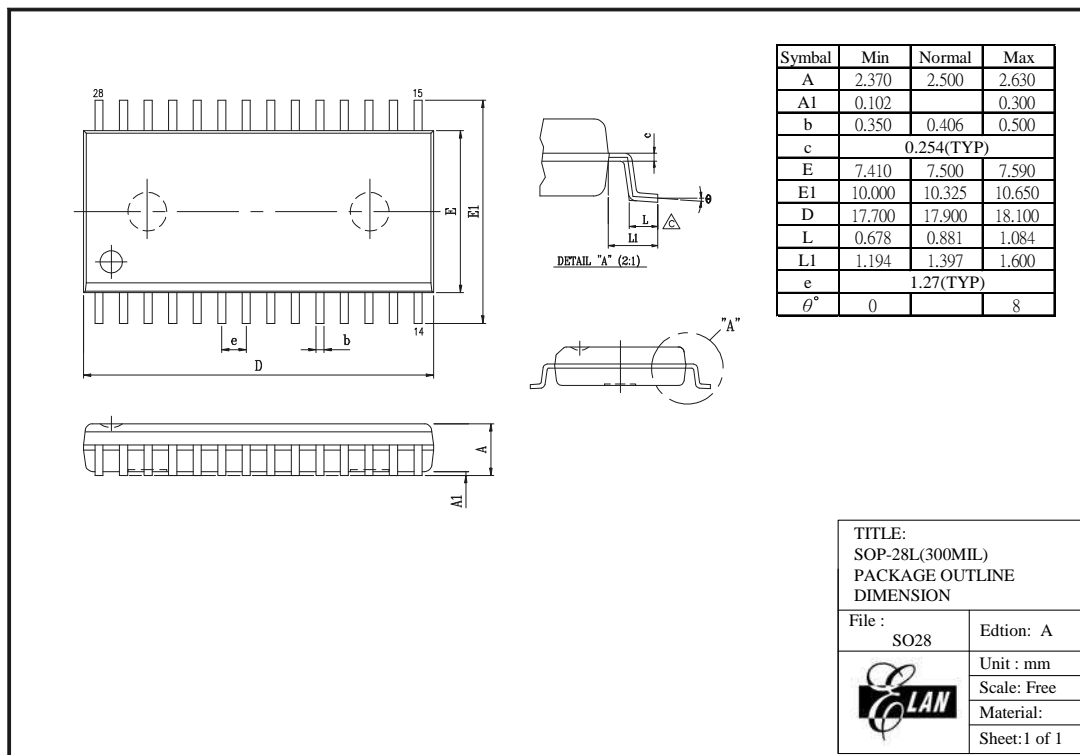

Figure B-7 EM78F644/544N 28-Pin SOP Package Type

B.2.3 24-Pin Skinny DIP Package

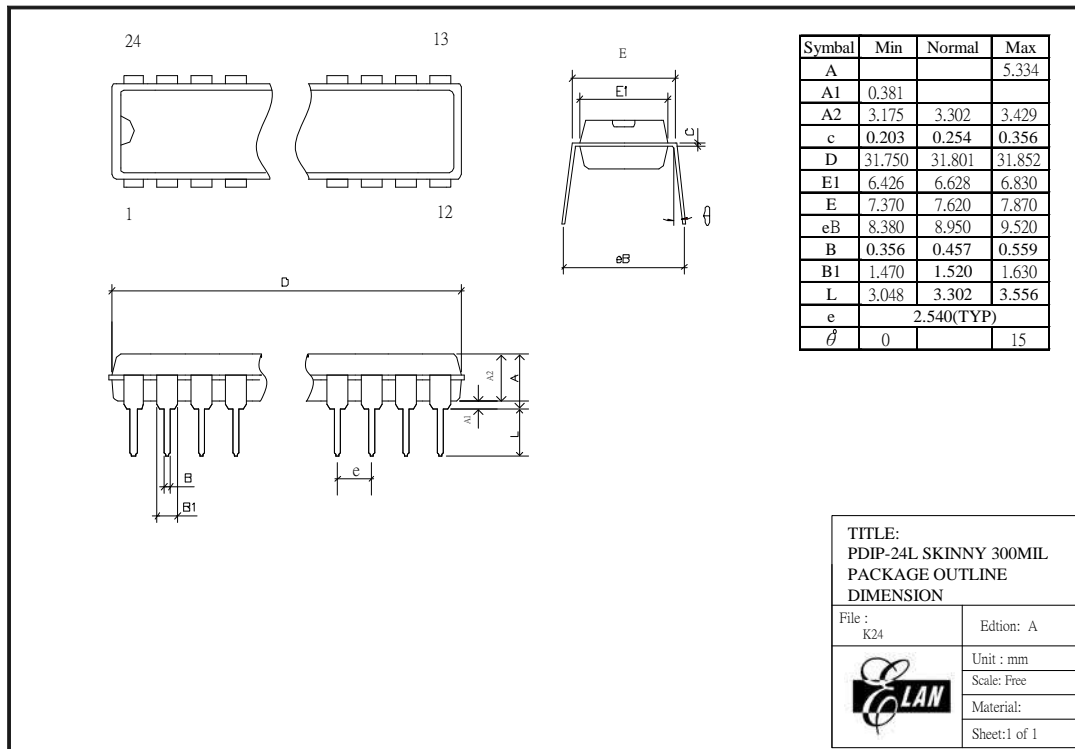

Figure B-8 EM78F644/544N 24-Pin Skinny DIP Package Type

B.2.4 24-Pin SOP Package

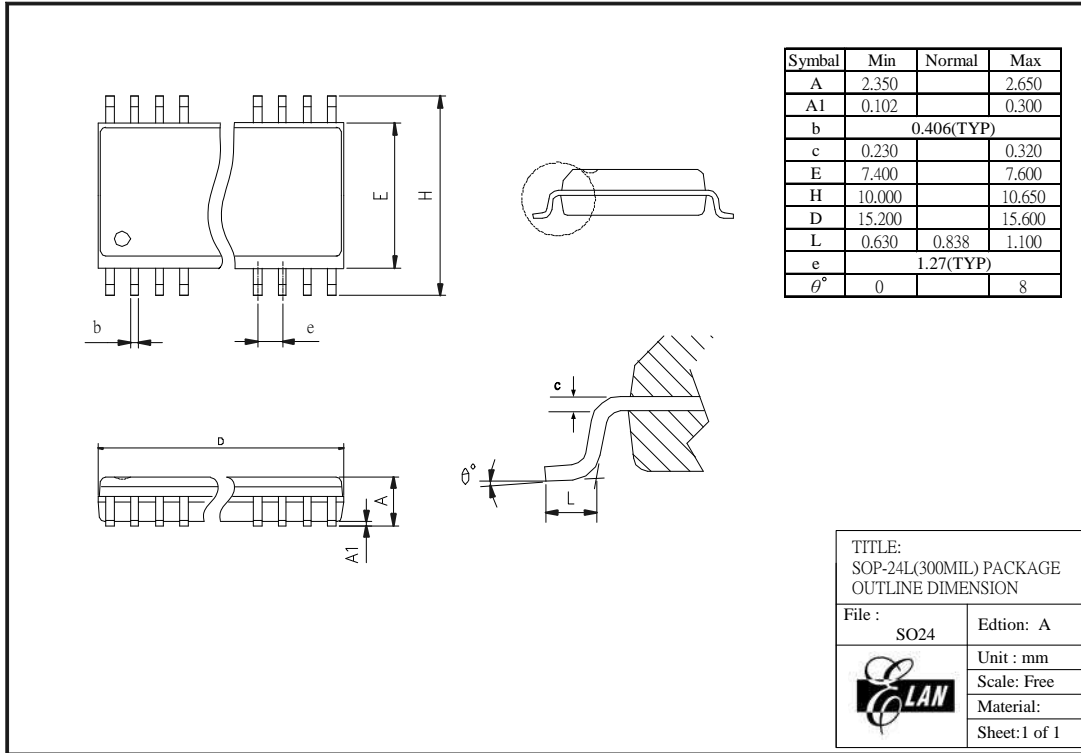

Figure B-9 EM78F644/544N 24-Pin SOP Package Type

B.3 EM78F642/542N

B.3.1 20-Pin DIP Package

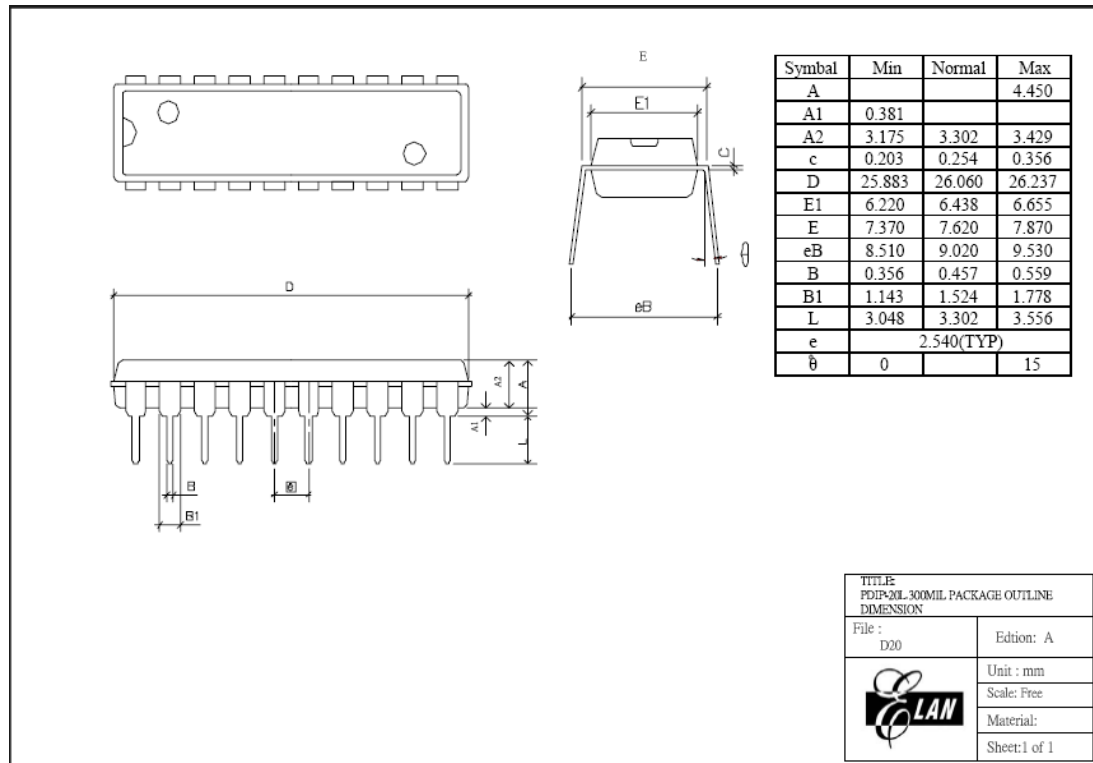

Figure B-10 EM78F642/542N 20-Pin DIP Package Type

B.3.2 20-Pin SOP Package

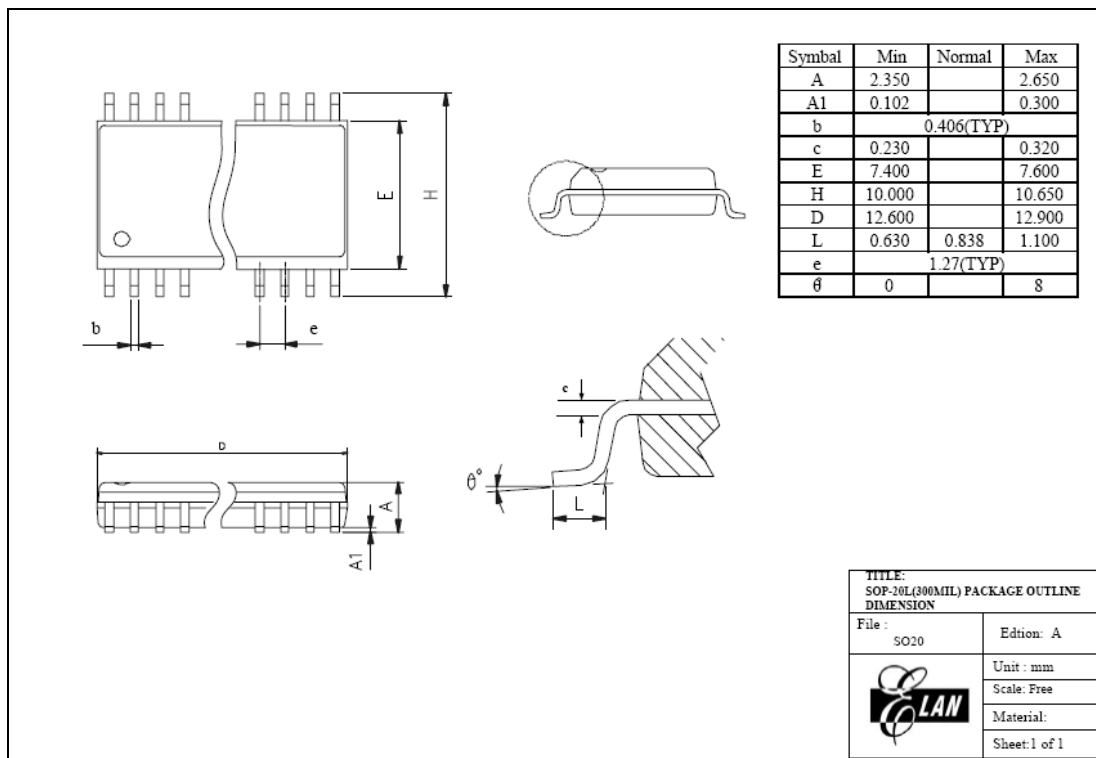

Figure B-11 EM78F642/542N 20-Pin SOP Package Type

B.3.3 20-Pin SSOP Package

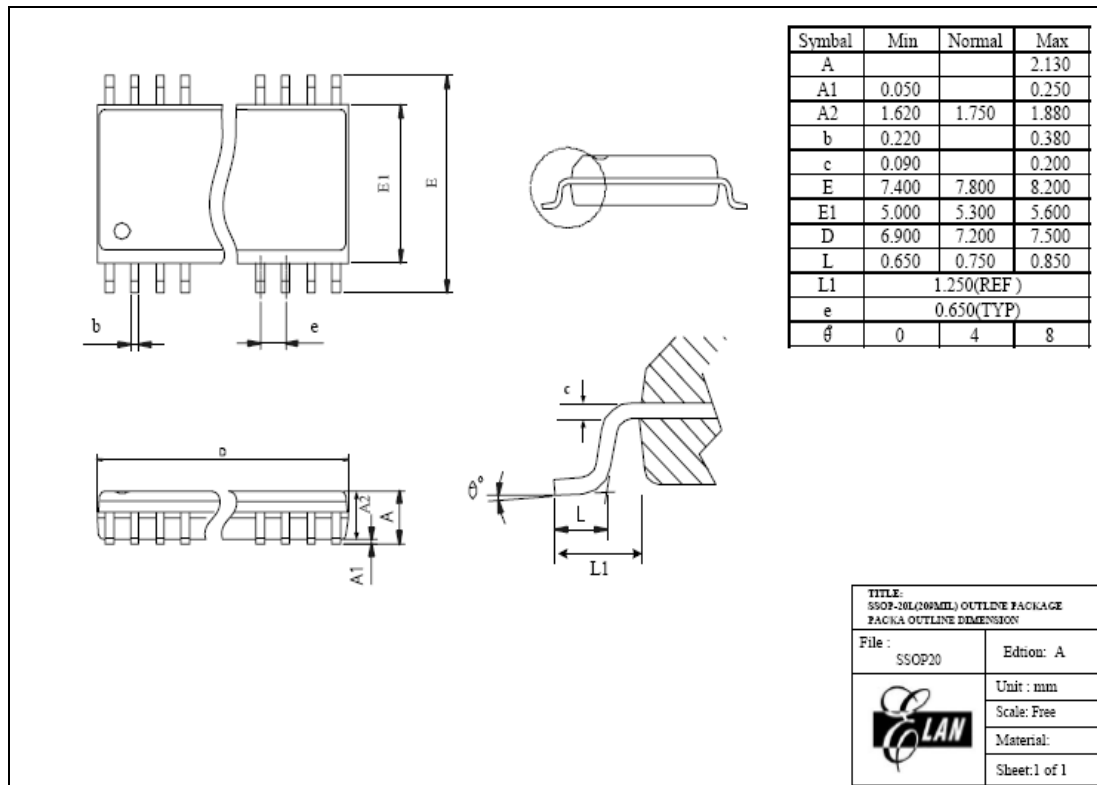

Figure B-12 EM78F642/542N 20-Pin SSOP Package Type

B.3.4 18-Pin DIP Package

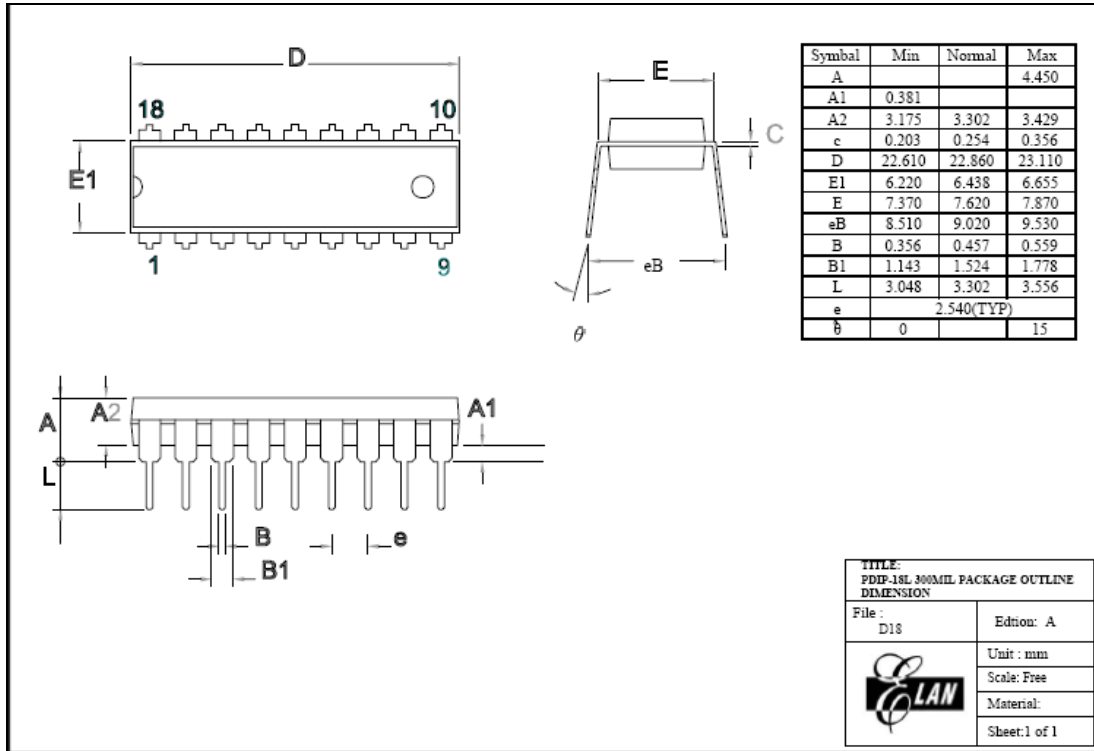

Figure B-13 EM78F642/542N 18-Pin DIP Package Type

B.3.5 18-Pin SOP Package

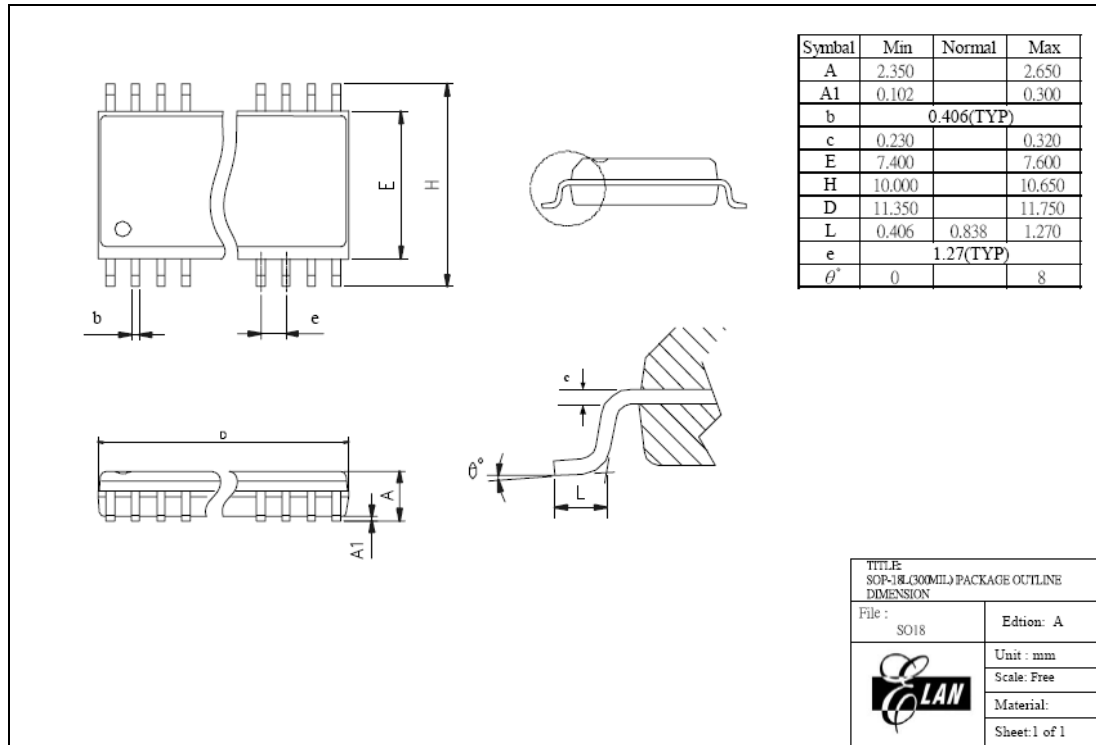

Figure B-14 EM78F642/542N 18-Pin SOP Package Type

B.4 EM78F641/541N

B.4.1 16-Pin DIP Package

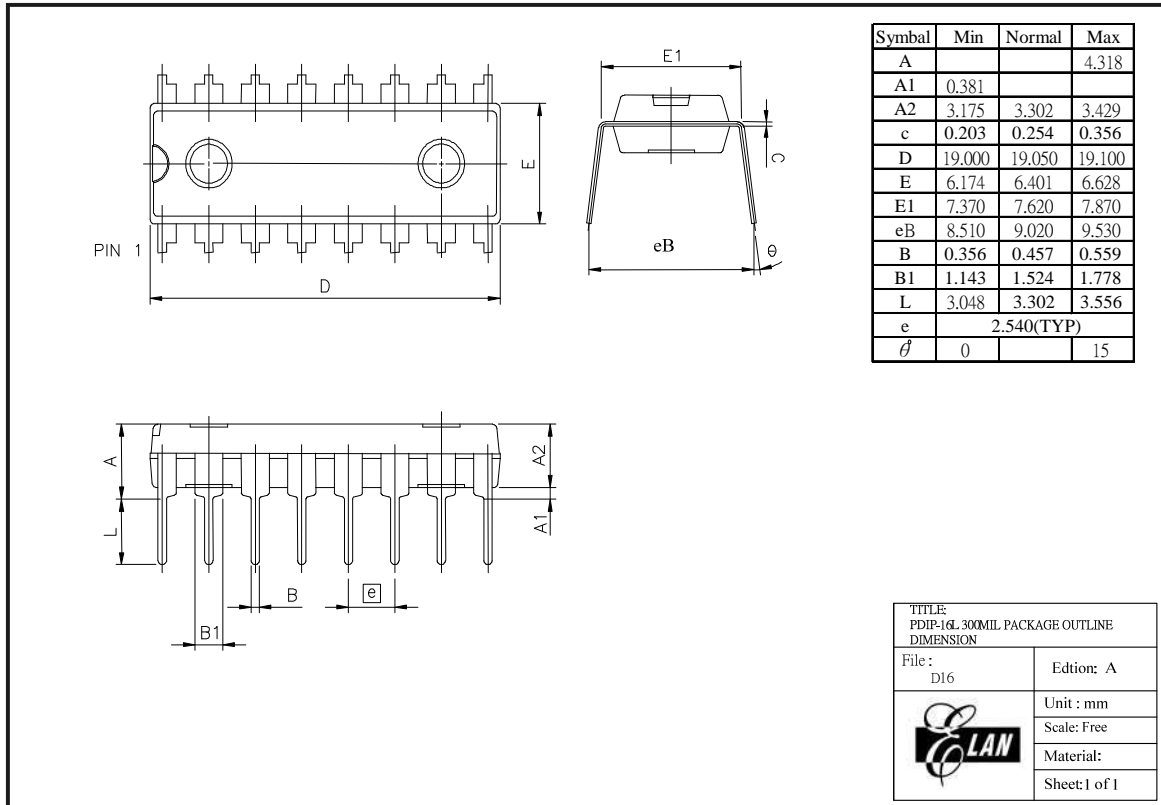

Figure B-15 EM78F641/541N 16-Pin DIP Package Type

B.4.2 16-Pin SOP Package

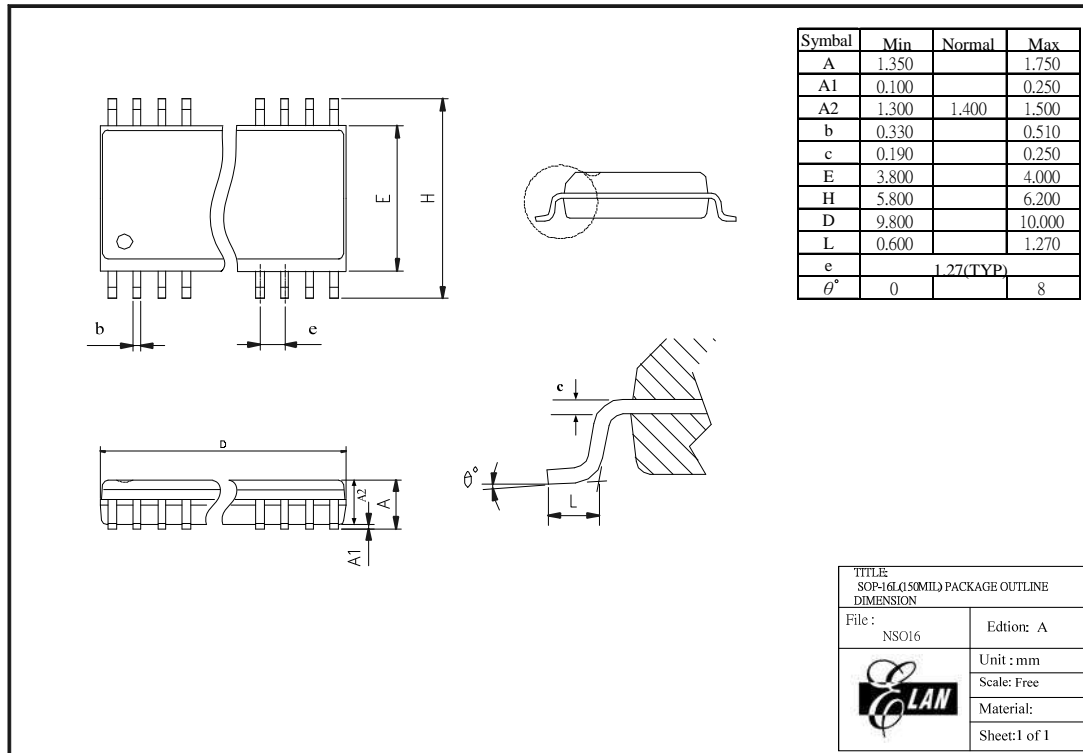

Figure B-16 EM78F641/541N 16-Pin SOP Package Type

B.4.3 10-Pin MSOP Package

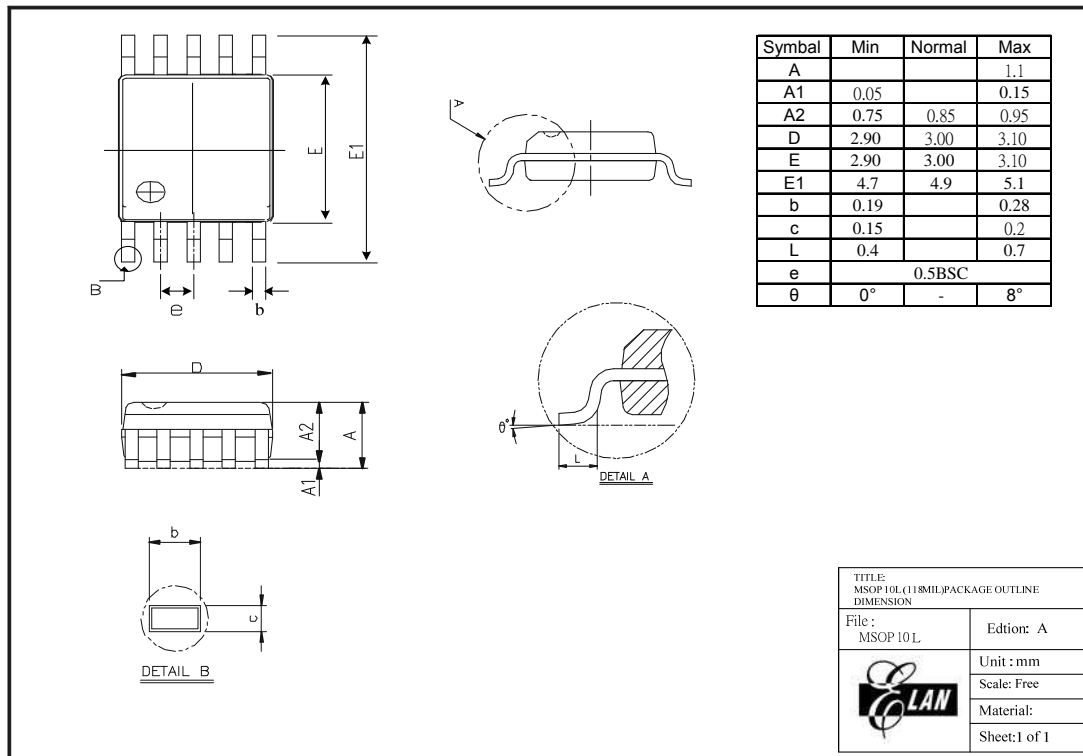

Figure B-17 EM78F641/541N 10-Pin MSOP Package Type

C Quality Assurance and Reliability

Test Category	Test Conditions	Remarks
Solderability	Solder temperature= $245 \pm 5^{\circ}\text{C}$, for 5 seconds up to the stopper using a rosin-type flux	-
Pre-condition	Step 1: TCT, 65°C (15 min)~ 150°C (15 min), 10 cycles	For SMD IC (such as SOP, QFP, SOJ, etc)
	Step 2: Bake at 125°C , TD (endurance) = 24 hrs	
	Step 3: Soak at $30^{\circ}\text{C}/60\%$, TD (endurance) = 192 hrs	
	Step 4: IR flow 3 cycles (Pkg thickness ≥ 2.5 mm or Pkg volume ≥ 350 mm ³ ---- $225 \pm 5^{\circ}\text{C}$) (Pkg thickness ≤ 2.5 mm or Pkg volume ≤ 350 mm ³ ---- $240 \pm 5^{\circ}\text{C}$)	
Temperature cycle test	-65°C (15 min)~ 150°C (15 min), 200 cycles	-
Pressure cooker test	TA = 121°C , RH = 100%, pressure=2 atm, TD (endurance) = 96 hrs	-
High temperature / High humidity test	TA= 85°C , RH=85% · TD (endurance) = 168, 500 hrs	-
High-temperature storage life	TA= 150°C , TD (endurance) = 500, 1000 hrs	-
High-temperature operating life	TA= 125°C , VCC = Max. operating voltage, TD (endurance) = 168, 500, 1000 hrs	-
Latch-up	TA= 25°C , VCC = Max. operating voltage, 150mA/20V	-
ESD (HBM)	TA= 25°C , $\geq \pm 3\text{KV} $	IP_ND,OP_ND,IO_ND IP_NS,OP_NS,IO_NS IP_PD,OP_PD,IO_PD,
ESD (MM)	TA= 25°C , $\geq \pm 300\text{V} $	IP_PS,OP_PS,IO_PS, VDD-VSS(+),VDD_VSS (-) mode

C.1 Address Trap Detect

The MCU is embedded with an “Address Trap Detect” feature. It is one of the fail-safe functions that detects MCU malfunction caused by noise or the like. Whenever the MCU attempts to fetch an instruction from a certain section of ROM, an internal recovery circuit is auto started. If a noise-caused address error is detected, the MCU will repeat execution of the program until the noise is eliminated. The MCU will then continue to execute the next program.