

SURFCOIL[®] SMT INDUCTORS

FEATURES

- Lead free, ROHS Compliant
- High Q
- High self-resonant frequency including nonmagnetic models in microwave range
- Shielded series use ferrite filled encapsulation to reduce external magnetic coupling
- Low DC resistance
- Carrier and reel packaging is standard
- Ten case sizes

SPECIFICATIONS

Electrical

- Inductance & Q, etc.: See tables
- Temperature range -20°C to $+85^{\circ}\text{C}$, except GLY, GLYC, GLZ, GLZB and GLZP Models are -40°C to $+85^{\circ}\text{C}$
 - Change of L = $\pm 10\%$ max, except GLX, GLY, GLYC, GLZ, GLZB and GLZP Models are $\pm 5\%$
 - Change of Q = $\pm 20\%$ max, except GLY, GLYC, GLZ, GLZB and GLZP Models are $\pm 25\%$
- Rated Current: See tables. Current rating is determined by either or both of the following conditions:
 1. Self heating raises SURFCOIL temperature 20°C
 2. Inductance value reduced by 10% from saturation effect

Mechanical (Chip Inductors)

- Suitable for wave flow soldering, infrared, and vapor phase reflow (typically over 90% coverage)
- Withstands soldering temperatures without damage
- Fully encapsulated and thermally cycled for stability and highest reliability

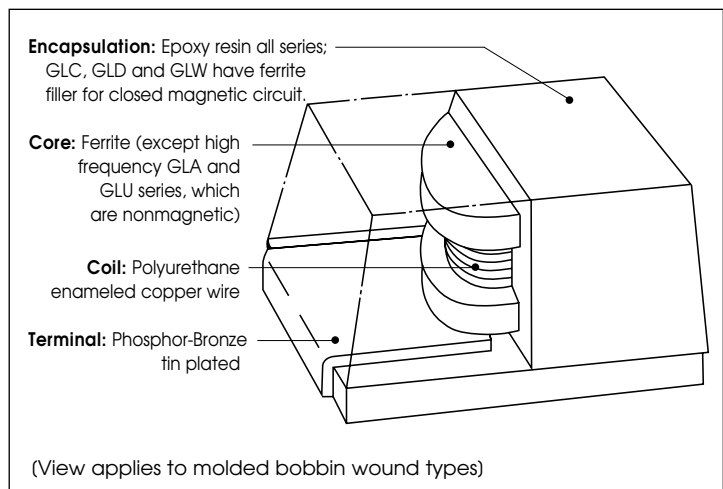
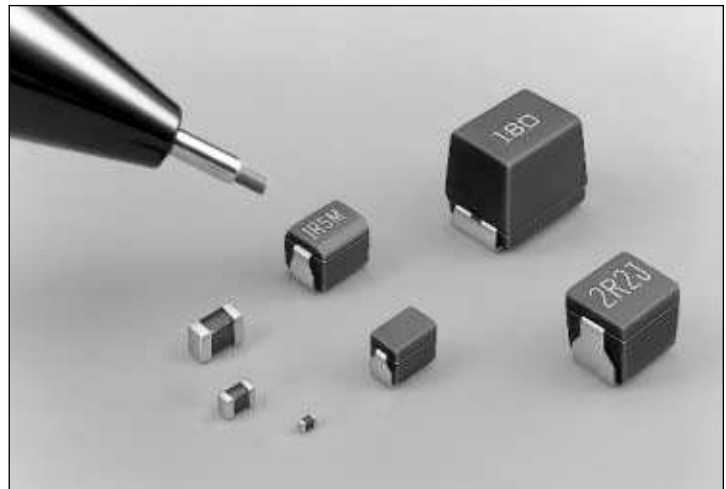
**Sprague-Goodman Electronics, Inc.**

1700 SHAMES DRIVE, WESTBURY, NY 11590
TEL: 516-334-8700 • FAX: 516-334-8771
E-MAIL: info@spraguegoodman.com

GLZ SERIES — LASER CUT 0402 SIZE

Inductance L (nH)	Standard Inductance Tolerance	Model No.	SRF (MHz) min	Q min	Q/L Test Freq. (MHz)	Rated Current (mA)	DCR (Ω) max
1.0	± 0.3 nH	GLZ1N030	6000	8	100	400	0.05
1.2	± 0.3 nH	GLZ1N225	6000	8	100	400	0.06
1.5	± 0.3 nH	GLZ1N520	6000	8	100	400	0.07
1.8	± 0.3 nH	GLZ1N817	6000	8	100	400	0.08
2.2	± 0.3 nH	GLZ2N214	6000	8	100	400	0.09
2.7	± 0.3 nH	GLZ2N711	5500	8	100	400	0.10
3.3	± 0.3 nH	GLZ3N309	5500	8	100	400	0.12
3.9	± 0.3 nH	GLZ3N908	5200	8	100	360	0.15
4.7	± 0.3 nH	GLZ4N706	4800	8	100	360	0.17
5.6	± 0.3 nH	GLZ5N605	4600	8	100	340	0.19
6.8	± 5%	GLZ6N805	4000	8	100	320	0.30
8.2	± 5%	GLZ8N205	3500	8	100	320	0.35
10.0	± 5%	GLZ10N05	2800	8	100	320	0.41
12.0	± 5%	GLZ12N05	2800	8	100	320	0.45
15.0	± 5%	GLZ15N05	2500	8	100	240	0.60
18.0	± 5%	GLZ18N05	2200	8	100	240	0.70
22.0	± 5%	GLZ22N05	2000	8	100	200	0.80
27.0	± 5%	GLZ27N05	1800	8	100	200	1.20
33.0	± 5%	GLZ33N05	1800	8	100	170	1.40
39.0	± 5%	GLZ39N05	1800	8	100	150	1.70
47.0	± 5%	GLZ47N05	1800	8	100	140	2.10
56.0	± 5%	GLZ56N05	1500	8	100	130	2.50
68.0	± 5%	GLZ68N05	1500	8	100	120	4.00
82.0	± 5%	GLZ82N05	1400	8	100	110	4.50
100.0	± 5%	GLZR1005	1200	8	100	90	5.50

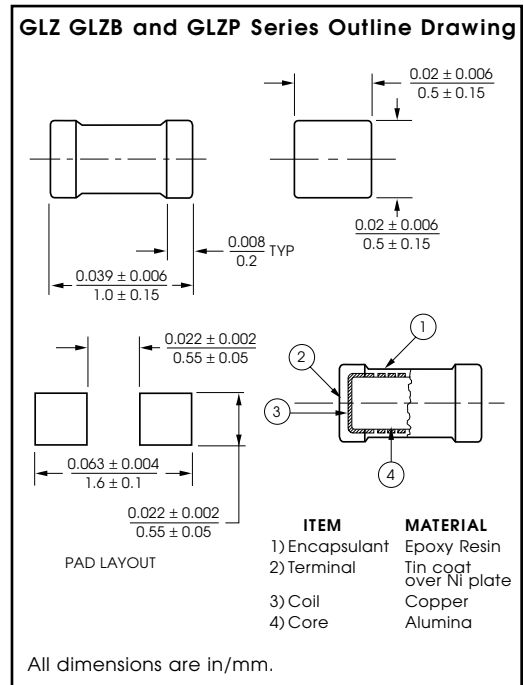
GLZB SERIES — HIGH Q LASER CUT 0402 SIZE

Inductance L (nH)	Standard Inductance Tolerance	Inductance Test Freq. (MHz)	Model No.	SRF (MHz) min	Q Typ (800 MHz)	Q min (100 MHz)	Rated Current (mA)	DCR (Ω) max
1.0	± 0.2 nH	100	GLZB1N020	6000	41	10	400	0.05
1.2	± 0.2 nH	100	GLZB1N217	6000	41	10	400	0.06
1.5	± 0.2 nH	100	GLZB1N513	6000	40	10	400	0.07
1.8	± 0.2 nH	100	GLZB1N811	6000	40	10	400	0.08
2.2	± 0.2 nH	100	GLZB2N209	6000	40	10	400	0.09
2.7	± 0.2 nH	100	GLZB2N707	5500	40	10	400	0.10
3.3	± 0.2 nH	100	GLZB3N306	5500	39	10	400	0.12
3.9	± 0.2 nH	100	GLZB3N905	5200	39	10	360	0.15
4.7	± 0.2 nH	100	GLZB4N704	4800	39	10	360	0.17
5.6	± 0.2 nH	100	GLZB5N604	4600	39	10	340	0.19
6.8	± 0.2 nH	100	GLZB6N803	4000	39	10	320	0.30
8.2	± 0.2 nH	100	GLZB8N202	3500	39	10	320	0.35
10.0	± 2%	100	GLZB10002	2800	39	10	320	0.41
12.0	± 2%	100	GLZB12002	2800	38	10	320	0.45
15.0	± 2%	100	GLZB15002	2500	36	10	240	0.60
18.0	± 2%	100	GLZB18002	2200	36	10	240	0.70
22.0	± 2%	100	GLZB22002	2200	36	10	200	0.80
27.0	± 2%	100	GLZB27002	1800	36	10	200	1.20
33.0	± 2%	100	GLZB33002	1800	35	10	170	1.40
39.0	± 2%	100	GLZB39002	1800	35	10	170	1.70

GLZP SERIES — HIGH CURRENT LOW DCR LASER CUT 0402 SIZE

Inductance L (nH)	Standard Inductance Tolerance	Model No.	SRF (GHz) min	Q min	Q/L Test Frequency (MHz)	Rated Current (A)	DCR (Ω) max
2.2	± 0.3 nH	GLZP2N214	5.3	7	100	1.9	0.04
2.7	± 0.3 nH	GLZP2N711	5.3	7	100	1.8	0.05
3.3	± 0.3 nH	GLZP3N309	5.0	7	100	1.5	0.07
3.9	± 0.3 nH	GLZP3N908	4.8	7	100	1.4	0.08
4.7	± 0.3 nH	GLZP4N706	4.6	7	100	1.3	0.10
5.6	± 0.3 nH	GLZP5N605	4.2	7	100	1.2	0.12
6.8	± 5%	GLZP6N805	4.0	7	100	1.1	0.16
8.2	± 5%	GLZP8N205	3.7	7	100	0.90	0.21
10.0	± 5%	GLZP10N05	3.2	7	100	0.75	0.26

Carrier and reel specifications on page 12.

GLY SERIES — LASER CUT 0603 SIZE

Inductance L (nH) (100 MHz)	Standard Inductance Tolerance*	Model No.	SRF (GHz) min	Q Typ (800 MHz)	Q min (100 MHz)	Rated Current (mA)	DCR (Ω) max
1.0	± 0.3 nH	GLY1N030	6.0	47	7	500	0.05
1.2	± 0.3 nH	GLY1N225	6.0	47	7	500	0.06
1.5	± 0.3 nH	GLY1N520	6.0	47	8	500	0.07
1.8	± 0.3 nH	GLY1N817	6.0	45	8	500	0.08
2.2	± 0.3 nH	GLY2N214	6.0	35	8	500	0.09
2.7	± 0.3 nH	GLY2N711	6.0	35	8	500	0.10
3.3	± 0.3 nH	GLY3N309	5.5	35	9	500	0.12
3.9	± 5%	GLY3N905	5.5	36	9	450	0.15
4.7	± 5%	GLY4N705	4.8	36	9	450	0.17
5.6	± 5%	GLY5N605	4.6	36	9	430	0.18
6.8	± 5%	GLY6N805	3.5	36	9	430	0.20
8.2	± 5%	GLY8N205	3.5	36	9	400	0.28
10.0	± 5%	GLY10N05	2.8	37	10	400	0.32
12.0	± 5%	GLY12N05	2.8	37	10	400	0.35
15.0	± 5%	GLY15N05	2.5	38	10	350	0.41
18.0	± 5%	GLY18N05	2.3	39	10	350	0.45
22.0	± 5%	GLY22N05	2.0	40	10	300	0.50
27.0	± 5%	GLY27N05	2.0	41	10	300	0.55
33.0	± 5%	GLY33N05	1.8	40	10	300	0.60
39.0	± 5%	GLY39N05	1.8	39	11	300	0.80
47.0	± 5%	GLY47N05	1.8	38	11	250	0.95
56.0	± 5%	GLY56N05	1.8	35	12	250	1.2
68.0	± 5%	GLY68N05	1.5	35	12	250	1.3
82.0	± 5%	GLY82N05	1.5	33	12	250	1.5
100.0	± 5%	GLYR1005	1.3	30	12	200	1.8
120.0	± 5%	GLYR1205	1.2	25	5	130	3.0
150.0	± 5%	GLYR1505	1.1	22	5	100	4.5
180.0	± 5%	GLYR1805	1.0	20	4	80	6.5
220.0	± 5%	GLYR2205	0.9	17	4	70	7.5

* ± 0.2 nH inductance tolerance is available for inductance values from 1.0 to 8.2 nH. ± 2% inductance tolerance is available for inductance values of 10.0 nH and up. Consult factory regarding these special units.

GLYC SERIES — HIGH CURRENT LOW DCR LASER CUT 0603 SIZE

Inductance L (nH) (100 MHz)	Standard Inductance Tolerance	Model No.	SRF (GHz) min	Q min (100 MHz)	Rated Current (A)	DCR (mΩ) max
2.2	± 10%	GLYC2N210	6.0	8	2.1	30
2.7	± 10%	GLYC2N710	5.0	8	2.1	30
3.3	± 10%	GLYC3N310	5.0	8	2.1	40
3.9	± 10%	GLYC3N910	5.2	9	2.1	40
4.7	± 10%	GLYC4N710	4.8	9	2.1	50
5.6	± 10%	GLYC5N610	4.6	9	2.1	55
6.8	± 10%	GLYC6N810	4.0	9	1.9	55
8.2	± 10%	GLYC8N210	3.5	9	1.7	60
10.0	± 10%	GLYC10N10	2.8	9	1.4	65
12.0	± 10%	GLYC12N10	2.5	9	1.3	80
15.0	± 10%	GLYC15N10	2.2	9	0.9	100
18.0	± 10%	GLYC18N10	2.0	9	0.8	120
22.0	± 10%	GLYC22N10	1.8	9	0.7	150

Carrier and reel specifications on page 12.

GLY and GLYC Series Outline Drawing

ITEM
 1) Encapsulant
 2) Terminal
 3) Coil
 4) Core

MATERIAL
 Epoxy Resin
 Tin coat over Ni plate
 Copper
 Alumina

All dimensions are in/mm.

TYPICAL Q VERSUS FREQUENCY—GLY AND GLYC Series

GLX SERIES — HIGH FREQUENCY NONMAGNETIC WIREWOUND 0805 SIZE

Inductance L (μH)	Standard Inductance Tolerance*	Model No.	SRF (MHz) min	Q min	Q/L Test Frequency (MHz)	Rated Current (mA)	DCR (Ω) max
0.010	± 10%	GLX10N10	2500	10	100	540	0.18
0.012	± 10%	GLX12N10	2500	10	100	535	0.23
0.015	± 10%	GLX15N10	2500	12	100	520	0.23
0.018	± 10%	GLX18N10	2000	12	100	480	0.29
0.022	± 10%	GLX22N10	2000	15	100	465	0.29
0.027	± 10%	GLX27N10	1800	15	100	455	0.34
0.033	± 10%	GLX33N10	1500	15	100	395	0.39
0.039	± 10%	GLX39N10	1500	15	100	390	0.40
0.047	± 10%	GLX47N10	1000	15	100	385	0.46
0.056	± 10%	GLX56N10	1000	15	100	360	0.51
0.068	± 10%	GLX68N10	800	15	100	340	0.57
0.082	± 10%	GLX82N10	800	15	100	330	0.62
0.10	± 10%	GLXR1010	800	8	25.2	285	0.86
0.12	± 10%	GLXR1210	600	8	25.2	275	0.99
0.15	± 10%	GLXR1510	600	10	25.2	230	1.47
0.18	± 10%	GLXR1810	600	10	25.2	195	1.61
0.22	± 10%	GLXR2210	500	10	25.2	170	1.83
0.27	± 10%	GLXR2710	300	10	25.2	165	1.95
0.33	± 10%	GLXR3310	200	10	25.2	160	2.16
0.39	± 10%	GLXR3910	150	10	25.2	150	2.37
0.47	± 10%	GLXR4710	150	10	25.2	145	2.56
0.56	± 10%	GLXR5610	100	10	25.2	140	2.69
0.68	± 10%	GLXR6810	100	10	25.2	130	3.02
0.82	± 10%	GLXR8210	80	10	25.2	125	3.38
1.00	± 10%	GLX1R010	80	8	7.96	120	3.87

*±5% Inductance tolerance is available for inductance values of 0.033 μH and up.

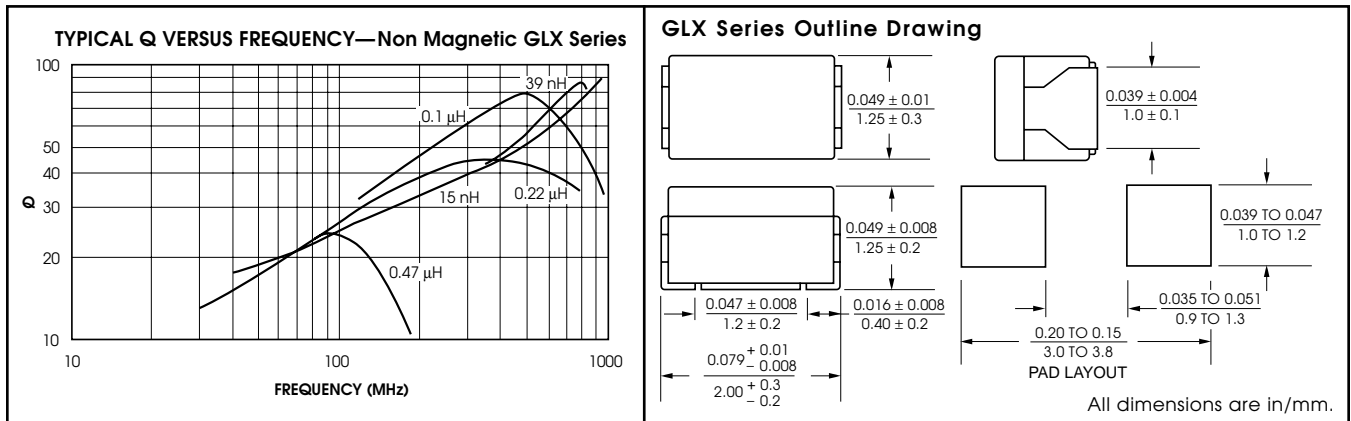

GLW SERIES — HIGH CURRENT MOLDED BOBBIN WOUND 1008 SIZE

Inductance L (μH)	Standard Inductance Tolerance	Model No.	SRF (MHz) min	Q min	Q/L Test Freq. (MHz)	Rated Current (mA)	DCR (Ω) max
1.0	± 20%	GLW1R020	95	10	7.96	475	0.45
1.5	± 20%	GLW1R520	85	10	7.96	435	0.55
2.2	± 20%	GLW2R220	65	10	7.96	390	0.65
3.3	± 20%	GLW3R320	55	8	7.96	340	0.85
4.7	± 20%	GLW4R720	43	8	7.96	285	1.2
6.8	± 10%	GLW6R810	39	8	7.96	275	1.3
10.0	± 10%	GLW10010	32	20	2.52	210	2.2
12.0	± 10%	GLW12010	25	20	2.52	195	2.7
15.0	± 10%	GLW15010	21	20	2.52	175	3.2
22.0	± 10%	GLW22010	18	20	2.52	160	4.0
33.0	± 10%	GLW33010	16	20	2.52	120	6.5

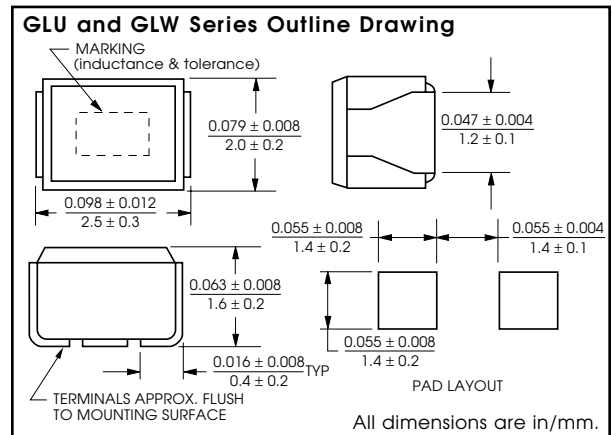

Carrier and reel specifications on page 12.

GLU SERIES — MOLDED BOBBIN WOUND 1008 SIZE

Inductance L (μH)	Standard Inductance Tolerance*	Model No.	SRF (MHz) min	Q min	Q/L Test Freq. (MHz)	Rated Current (mA)	DCR (Ω) max
0.22	± 10%	GLUR2210M	230	25	25.2	190	0.70
0.27	± 10%	GLUR2710M	210	25	25.2	180	0.75
0.33	± 10%	GLUR3310M	190	25	25.2	170	0.85
0.39	± 10%	GLUR3910M	175	25	25.2	160	0.95
0.47	± 10%	GLUR4710M	160	25	25.2	155	1.00
0.56	± 10%	GLUR5610M	150	25	25.2	150	1.10
0.68	± 10%	GLUR6810M	135	25	25.2	140	1.25
0.82	± 10%	GLUR8210M	125	25	25.2	130	1.40
1.00	± 10%	GLU1R010	115	25	7.96	195	0.65
1.20	± 10%	GLU1R210	100	25	7.96	180	0.75
1.50	± 10%	GLU1R510	90	25	7.96	170	0.85
1.80	± 10%	GLU1R810	85	25	7.96	160	0.95
2.20	± 10%	GLU2R210	80	25	7.96	155	1.05
2.70	± 10%	GLU2R710	75	25	7.96	145	1.20
3.30	± 10%	GLU3R310	65	25	7.96	135	1.30
3.90	± 10%	GLU3R910	60	25	7.96	130	1.40
4.70	± 10%	GLU4R710	55	25	7.96	125	1.55
5.60	± 10%	GLU5R610	50	25	7.96	120	1.75
6.80	± 10%	GLU6R810	45	25	7.96	115	1.95
8.20	± 10%	GLU8R210	40	25	7.96	105	2.20
10.0	± 5%	GLU10005	32	25	2.52	80	3.5
12.0	± 5%	GLU12005	30	25	2.52	75	3.8
15.0	± 5%	GLU15005	28	25	2.52	70	4.4
18.0	± 5%	GLU18005	25	25	2.52	65	5.0
22.0	± 5%	GLU22005	22	25	2.52	60	5.8
27.0	± 5%	GLU27005	21	20	2.52	115	6.3
33.0	± 5%	GLU33005	20	20	2.52	110	7.1
39.0	± 5%	GLU39005	18	20	2.52	90	9.5
47.0	± 5%	GLU47005	17	20	2.52	80	11.0
56.0	± 5%	GLU56005	16	20	2.52	75	12.1
68.0	± 5%	GLU68005	15	20	2.52	70	16.6
82.0	± 5%	GLU82005	13	20	2.52	65	19.0
100.0	± 5%	GLU10105	12	15	0.796	60	21.0

* ±5% Inductance tolerance is available for inductance values up to 8.2 μH. Carrier and reel specifications on page 12.

GLU SERIES — NONMAGNETIC HIGH FREQUENCY MOLDED BOBBIN WOUND 1008 SIZE

Inductance L (μH)	Standard Inductance Tolerance*	Model No.	SRF (MHz) min	Q min	Q/L Test Freq. (MHz)	Rated Current (mA)	DCR (Ω) max
0.010	± 10%	GLU10N10	2500	10	100	280	0.32
0.012	± 10%	GLU12N10	2200	10	100	270	0.34
0.015	± 10%	GLU15N10	1800	10	100	255	0.38
0.018	± 10%	GLU18N10	1550	10	100	250	0.40
0.022	± 10%	GLU22N10	1350	15	100	240	0.43
0.027	± 10%	GLU27N10	1150	15	100	230	0.47
0.033	± 10%	GLU33N10	1000	15	100	220	0.51
0.039	± 10%	GLU39N10	890	15	100	215	0.55
0.047	± 10%	GLU47N10	770	15	100.	205	0.59
0.056	± 10%	GLU56N10	670	15	100.	200	0.63
0.068	± 10%	GLU68N10	590	15	100.	190	0.68
0.082	± 10%	GLU82N10	520	15	100.	185	0.73
0.10	± 10%	GLUR1010	460	10	25.2	175	0.80
0.12	± 10%	GLUR1210	400	10	25.2	170	0.87
0.15	± 10%	GLUR1510	340	10	25.2	160	0.98
0.18	± 10%	GLUR1810	300	10	25.2	155	1.05
0.22	± 10%	GLUR2210	260	10	25.2	145	1.15
0.27	± 10%	GLUR2710	230	10	25.2	140	1.25
0.33	± 10%	GLUR3310	200	10	25.2	135	1.37
0.39	± 10%	GLUR3910	180	10	25.2	130	1.47
0.47	± 10%	GLUR4710	160	10	25.2	125	1.58
0.56	± 10%	GLUR5610	145	10	25.2	120	1.70
0.68	± 10%	GLUR6810	130	10	25.2	110	1.85
0.82	± 10%	GLUR8210	100	10	25.2	100	2.10

*±5% Inductance tolerance is available for inductance values of 0.033 μH and up. Carrier and reel specifications on page 12.

GLA SERIES — MOLDED BOBBIN WOUND 1210 SIZE

Inductance L (μH)	Standard Inductance Tolerance †	Model No.	SRF (MHz) min	Q min	Q/L Test Freq. (MHz)	Rated Current (mA)	DCR (Ω) max
0.22	± 10%	GLAR2210M	230	25	25.2	360	0.29
0.27	± 10%	GLAR2710M	210	25	25.2	345	0.32
0.33	± 10%	GLAR3310M	190	25	25.2	330	0.35
0.39	± 10%	GLAR3910M	175	25	25.2	305	0.39
0.47	± 10%	GLAR4710M	160	25	25.2	290	0.44
0.56	± 10%	GLAR5610M	150	25	25.2	275	0.49
0.68	± 10%	GLAR6810M	135	25	25.2	260	0.55
0.82	± 10%	GLAR8210M	125	25	25.2	245	0.61
1.00	± 10%	GLA1R010	115	30 *	7.96	230	0.69
1.20	± 10%	GLA1R210	100	30 *	7.96	215	0.75
1.50	± 10%	GLA1R510	90	30 *	7.96	210	0.75
1.80	± 10%	GLA1R810	85	30 *	7.96	200	0.82
2.20	± 10%	GLA2R210	80	30 *	7.96	190	0.95
2.70	± 10%	GLA2R710	75	30 *	7.96	180	1.1
3.30	± 10%	GLA3R310	65	30 *	7.96	180 *	1.2 *
3.90	± 10%	GLA3R910	60	30 *	7.96	175 *	1.3 *
4.70	± 10%	GLA4R710	55	30 *	7.96	165 *	1.5
5.60	± 10%	GLA5R610	50	30 *	7.96	160 *	1.6 *
6.80	± 10%	GLA6R810	45	30 *	7.96	150 *	1.8 *
8.20	± 10%	GLA8R210	40	30 *	7.96	140 *	2.0 *
10.0	± 10%	GLA10010	36	30	2.52	140 *	2.1 *
12.0	± 10%	GLA12010	33	30	2.52	125 *	2.5 *
15.0	± 10%	GLA15010	30	30	2.52	120 *	2.8 *
18.0	± 10%	GLA18010	27	30	2.52	110 *	3.3 *
22.0	± 10%	GLA22010	25	30	2.52	105 *	3.7 *
27.0	± 10%	GLA27010	22	30	2.52	90 *	5.0 *
33.0	± 10%	GLA33010	20	30	2.52	85 *	5.6 **
39.0	± 10%	GLA39010	20	30	2.52	80 *	6.4 **
47.0	± 10%	GLA47010	15	30	2.52	75	7.0
56.0	± 10%	GLA56010	15	30	2.52	70	8.0
68.0	± 10%	GLA68010	15	30	2.52	65	9.0
82.0	± 10%	GLA82010	11	30 *	2.52	60	10.0
100.0	± 10%	GLA10110	10	20 *	0.796	60	10.0
120.0	± 10%	GLA12110	10	20 *	0.796	55	11.0
150.0	± 10%	GLA15110	8	20	0.796	50	15.0
180.0	± 10%	GLA18110	7	20	0.796	50	17.0
220.0	± 10%	GLA22110	7	20	0.796	45	21.0

† Inductance values from 1.0 μH and up also available with ±5% inductance tolerance. Consult factory regarding these special units.
 * Rerated 12/91 **Rerated 6/97

GLAC SERIES — HIGH POWER LOW DCR SHIELDED MOLDED BOBBIN WOUND 1210 SIZE

Inductance L (μH)	Standard Inductance Tolerance	Model No.	SRF (MHz) min	Q min	Q/L Test Freq. (MHz)	Rated Current (mA)	DCR (Ω) max
1.0	± 20%	GLAC1R020	100	7	7.96	500	0.09
1.5	± 20%	GLAC1R520	80	7	7.96	390	0.10
2.2	± 20%	GLAC2R220	65	7	7.96	350	0.13
3.3	± 20%	GLAC3R320	50	7	7.96	270	0.16
4.7	± 20%	GLAC4R720	46	7	7.96	240	0.18
6.8	± 20%	GLAC6R820	36	7	7.96	200	0.25
10.0	± 10%	GLAC10010	29	10	2.52	160	0.34
15.0	± 10%	GLAC15010	25	10	2.52	145	0.42
22.0	± 10%	GLAC22010	18	10	2.52	115	0.65
33.0	± 10%	GLAC33010	16	10	2.52	95	0.91
47.0	± 10%	GLAC47010	13	10	2.52	80	1.30
68.0	± 10%	GLAC68010	10	10	2.52	60	1.95
100.0	± 10%	GLAC10110	8	20	0.796	50	3.12
150.0	± 10%	GLAC15110	7	20	0.796	45	4.03
220.0	± 10%	GLAC22110	5	20	0.796	35	7.15
330.0	± 10%	GLAC33110	4	20	0.796	30	9.23

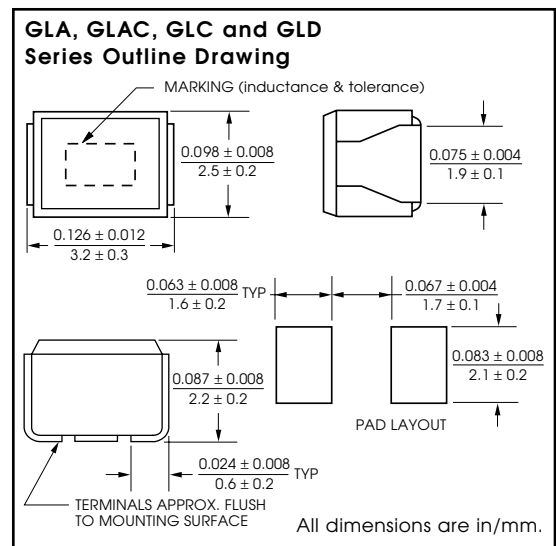

Carrier and reel specifications on page 12.

GLA SERIES — NONMAGNETIC HIGH FREQUENCY MOLDED BOBBIN WOUND 1210 SIZE

Inductance L (μH)	Standard Inductance Tolerance	Inductance Test Freq. (MHz)	Model No.	SRF (MHz) min	Q min	Q Test Frequency (MHz)	Rated Current (mA)	DCR (Ω) max
0.047	± 20%	100.0	GLA47N20	680	10	100.0	450	0.20
0.056	± 20%	100.0	GLA56N20	600	10	100.0	420	0.22
0.068	± 20%	100.0	GLA68N20	540	10	100.0	400	0.25
0.082	± 20%	100.0	GLA82N20	500	10	100.0	380	0.27
0.10	± 20%	100.0	GLAR1020	450	10	100.0	360	0.30
0.12	± 20%	25.2	GLAR1220	400	10	25.2	240	0.67
0.15	± 20%	25.2	GLAR1520	350	10	25.2	230	0.72
0.18	± 20%	25.2	GLAR1820	320	10	25.2	220	0.81
0.22	± 10%	1.0	GLAR2210	280	10	25.2	210	0.90
0.27	± 10%	1.0	GLAR2710	250	10	25.2	200	1.0
0.33	± 10%	1.0	GLAR3310	220	10	25.2	190	1.1
0.39	± 10%	1.0	GLAR3910	200	10	25.2	180	1.2
0.47	± 10%	1.0	GLAR4710	180	10	25.2	175	1.4
0.56	± 10%	1.0	GLAR5610	160	10	25.2	170	1.5
0.68	± 10%	1.0	GLAR6810	150	10	25.2	155	1.7
0.82	± 10%	1.0	GLAR8210	135	10	25.2	145	1.9
1.00	± 5%	1.0	GLA1R005	120	13	7.96	125	2.1
1.20	± 5%	1.0	GLA1R205	110	13	7.96	120	2.3
1.50	± 5%	1.0	GLA1R505	95	13	7.96	115	2.7
1.80	± 5%	1.0	GLA1R805	85	13	7.96	110	3.0
2.20	± 5%	1.0	GLA2R205	80	13	7.96	110	3.2
2.70	± 5%	1.0	GLA2R705	70	13	7.96	105	3.6
3.30	± 5%	1.0	GLA3R305	62	13	7.96	100	4.2
3.90	± 5%	1.0	GLA3R905	57	13	7.96	95	4.4
4.70	± 5%	1.0	GLA4R705	52	13	7.96	70	7.7
5.60	± 5%	1.0	GLA5R605	46	13	7.96	65	8.7
6.80	± 5%	1.0	GLA6R805	42	13	7.96	60	10.0
8.20	± 5%	1.0	GLA8R205	38	13	7.96	60	11.0

GLC SERIES — SHIELDED MOLDED BOBBIN WOUND 1210 SIZE

Inductance L (μH)	Standard Inductance Tolerance	Inductance Test Freq. (MHz)	Model No.	SRF (MHz) min	Q min	Q Test Frequency (MHz)	Rated Current (mA)	DCR (Ω) max
10.0	± 10%	1.0	GLC10010	30	40	5.0	18	1.8
12.0	± 10%	1.0	GLC12010	28	40	5.0	17	2.0
15.0	± 10%	1.0	GLC15010	25	40	5.0	15	2.2
18.0	± 10%	1.0	GLC18010	23	40	5.0	13	2.5
22.0	± 10%	1.0	GLC22010	20	40	5.0	12	2.8
27.0	± 10%	1.0	GLC27010	18	40	5.0	10	3.2
33.0	± 10%	1.0	GLC33010	17	40	5.0	10	3.5
39.0	± 10%	1.0	GLC39010	15	40	5.0	9	3.8
47.0	± 10%	1.0	GLC47010	14	40	5.0	8	4.0
56.0	± 10%	1.0	GLC56010	13	40	5.0	7	4.5
68.0	± 10%	1.0	GLC68010	12	40	1.5	6	5.0
82.0	± 10%	1.0	GLC82010	11	40	1.5	6	6.0
100.0	± 10%	1.0	GLC10110	10	40	1.5	5	7.0
120.0	± 10%	1.0	GLC12110	9	40	1.5	5	8.0
150.0	± 10%	0.1	GLC15110	5	40	1.5	5	9.0
180.0	± 10%	0.1	GLC18110	5	40	1.5	5	11.0
220.0	± 10%	0.1	GLC22110	4	40	1.5	5	12.0
270.0	± 10%	0.1	GLC27110	4	40	1.5	5	14.0

Carrier and reel specifications on page 12.

GLD SERIES — HIGH CURRENT SHIELDED MOLDED BOBBIN WOUND 1210 SIZE

Inductance L (μH)	Standard Inductance Tolerance	Model No.	SRF (MHz) min	Q min	Q/L Test Freq. (MHz)	Rated Current (mA)	DCR (Ω) max
1.0	± 20%	GLD1R020	150	7	7.96	600	0.15
1.5	± 20%	GLD1R520	110	7	7.96	550	0.18
2.2	± 20%	GLD2R220	80	7	7.96	500	0.23
3.3	± 20%	GLD3R320	58	7	7.96	400	0.28
4.7	± 20%	GLD4R720	46	7	7.96	350	0.34
6.8	± 20%	GLD6R820	38	7	7.96	300	0.42
10.0	± 10%	GLD10010	23	15	2.52	240	0.50
12.0	± 10%	GLD12010	21	15	2.52	230	0.60
15.0	± 10%	GLD15010	18	15	2.52	220	0.74
18.0	± 10%	GLD18010	17	15	2.52	205	0.90
22.0	± 10%	GLD22010	15	15	2.52	185	1.15
27.0	± 10%	GLD27010	13	15	2.52	165	1.45
33.0	± 10%	GLD33010	12	15	2.52	155	1.65
39.0	± 10%	GLD39010	11	15	2.52	145	1.90
47.0	± 10%	GLD47010	9.5	15	2.52	135	2.25
56.0	± 10%	GLD56010	8.5	15	2.52	110	3.30
68.0	± 10%	GLD68010	7.5	15	2.52	105	3.70
82.0	± 10%	GLD82010	7.0	15	2.52	100	4.20
100.0	± 10%	GLD10110	6.5	20	0.796	90	5.00
120.0	± 10%	GLD12110	6.0	20	0.796	75	7.00
150.0	± 10%	GLD15110	5.5	20	0.796	70	8.00
180.0	± 10%	GLD18110	5.0	20	0.796	65	9.50
220.0	± 10%	GLD22110	4.0	20	0.796	60	11.00
270.0	± 10%	GLD27110	3.5	20	0.796	55	14.50
330.0	± 10%	GLD33110	3.0	20	0.796	50	16.00

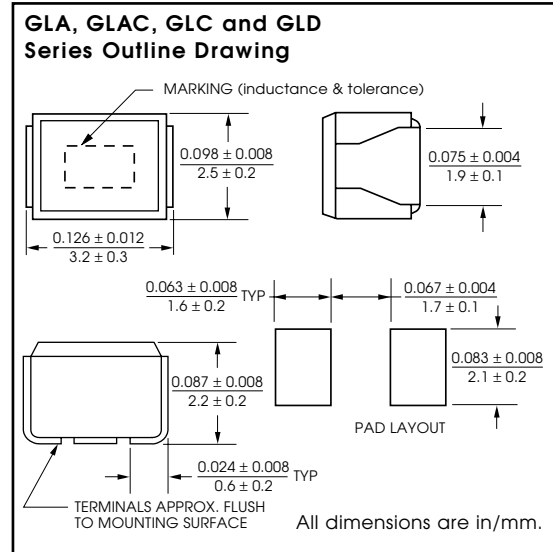

GLBP SERIES — HIGH CURRENT LOW DCR SHIELDED MOLDED BOBBIN WOUND 1812 SIZE

Inductance L (μH)	Standard Inductance Tolerance	Model No.	SRF (MHz) min	Q min	Q/L Test Freq. (MHz)	Rated Current (mA)	DCR (Ω) max
10.0	± 10%	GLBP10010	19	10	2.52	360	0.65
12.0	± 10%	GLBP12010	17	10	2.52	340	0.70
15.0	± 10%	GLBP15010	15	10	2.52	320	0.80
18.0	± 10%	GLBP18010	14	10	2.52	310	0.90
22.0	± 10%	GLBP22010	13	10	2.52	300	1.00
27.0	± 10%	GLBP27010	11	10	2.52	270	1.20
33.0	± 10%	GLBP33010	10	10	2.52	250	1.40
39.0	± 10%	GLBP39010	9.5	10	2.52	230	1.60
47.0	± 10%	GLBP47010	8.5	10	2.52	210	1.90
56.0	± 10%	GLBP56010	8.0	10	2.52	190	2.20
68.0	± 10%	GLBP68010	7.0	10	2.52	170	2.60
82.0	± 10%	GLBP82010	6.5	10	2.52	160	3.50
100.0	± 10%	GLBP10110	6.0	20	0.796	150	4.00
120.0	± 10%	GLBP12110	5.5	20	0.796	130	4.50
150.0	± 10%	GLBP15110	5.0	20	0.796	120	6.50
180.0	± 10%	GLBP18110	4.5	20	0.796	110	7.50
220.0	± 10%	GLBP22110	4.0	20	0.796	90	9.00

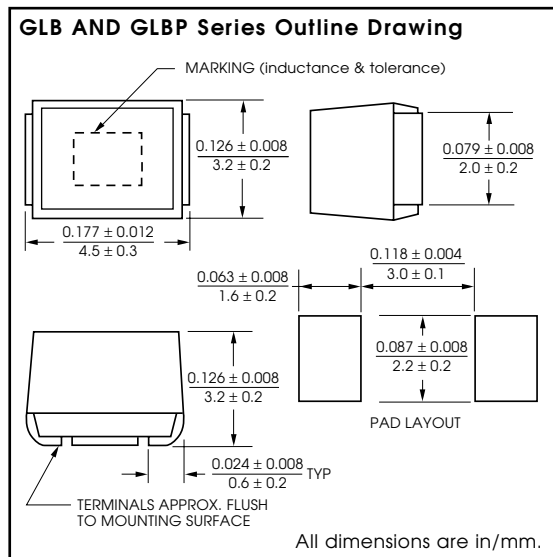

Carrier and reel specifications on page 12.

GLB SERIES — MOLDED BOBBIN WOUND 1812 SIZE

Inductance L (μH)	Standard Inductance Tolerance*	Inductance Test Freq. (MHz)	Model No.	SRF (MHz) min	Q min	Q Test Frequency (MHz)	Rated Current (mA)	DCR (Ω) max
0.22	± 20%	1.0	GLBR2220	230	30	25.20	700	0.30
0.27	± 20%	1.0	GLBR2720	200	30	25.20	650	0.32
0.33	± 20%	1.0	GLBR3320	180	30	25.20	630	0.35
0.39	± 20%	1.0	GLBR3920	155	30	25.20	620	0.37
0.47	± 20%	1.0	GLBR4720	135	30	25.20	580	0.40
0.56	± 20%	1.0	GLBR5620	120	30	25.20	560	0.42
0.68	± 20%	1.0	GLBR6820	105	30	25.20	530	0.48
0.82	± 20%	1.0	GLBR8220	90	30	25.20	500	0.50
1.00	± 20%	1.0	GLB1R020	80	30	25.20	470	0.52
1.20	± 20%	1.0	GLB1R220	70	30	25.20	460	0.55
1.50	± 20%	1.0	GLB1R520	60	30	25.20	430	0.61
1.80	± 20%	1.0	GLB1R820	50	30	7.96	410	0.61
2.20	± 20%	1.0	GLB2R220	45	50	7.96	410	0.61
2.70	± 20%	1.0	GLB2R720	43	50	7.96	400	0.61
3.30	± 20%	1.0	GLB3R320	39	50	7.96	380	0.66
3.90	± 20%	1.0	GLB3R920	36	50	7.96	360	0.74
4.70	± 20%	1.0	GLB4R720	33	50	5.00	350	0.81
5.60	± 20%	1.0	GLB5R620	30	50	5.00	330	0.88
6.80	± 20%	1.0	GLB6R820	26	50	5.00	310	1.00
8.20	± 20%	1.0	GLB8R220	24	50	5.00	250	1.60
10.0	± 10%	1.0	GLB10010	22	50	5.00	235	1.8
12.0	± 10%	1.0	GLB12010	20	50	5.00	225	1.9
15.0	± 10%	1.0	GLB15010	18	50	5.00	215	2.1
18.0	± 10%	1.0	GLB18010	16	50	2.52	205	2.3
22.0	± 10%	1.0	GLB22010	15	50	2.52	195	2.6
27.0	± 10%	1.0	GLB27010	13	50	2.52	185	2.9
33.0	± 10%	1.0	GLB33010	12	50	2.52	175	3.1
39.0	± 10%	1.0	GLB39010	10	50	2.52	165	3.6
47.0	± 10%	1.0	GLB47010	9.7	50	2.52	130	4.2
56.0	± 10%	0.1	GLB56010	9.0	40	2.52	125	4.7
68.0	± 10%	0.1	GLB68010	8.2	40	2.52	115	5.3
82.0	± 10%	0.1	GLB82010	7.5	40	2.52	110	5.9
100.0	± 10%	0.1	GLB10110	6.7	40	2.52	105	8.8
120.0	± 10%	0.1	GLB12110	6.1	40	1.50	100	10.0
150.0	± 10%	0.1	GLB15110	5.5	40	1.50	95	11.0
180.0	± 10%	0.1	GLB18110	5.1	40	1.50	85	13.0
220.0	± 10%	0.1	GLB22110	4.5	40	0.796	85	13.0
270.0	± 10%	0.1	GLB27110	4.1	40	0.796	80	14.0
330.0	± 10%	0.1	GLB33110	3.7	40	0.796	75	16.0
390.0	± 10%	0.1	GLB39110	3.3	40	0.796	70	19.0
470.0	± 10%	0.1	GLB47110	3.3	30	0.796	55	31.0
560.0	± 10%	0.1	GLB56110	2.7	30	0.796	50	35.0
680.0	± 10%	0.1	GLB68110	2.5	30	0.796	50	39.0
820.0	± 10%	0.1	GLB82110	2.4	30	0.796	45	45.0
1000.0	± 10%	0.1	GLB10210	2.1	30	0.796	40	53.0

* Inductance values from 1.00 to 8.2 μH also available with ±10% inductance tolerance.
Inductance values from 10.0 μH and up also available with ±5% inductance tolerance.
Consult factory regarding these special units.

Carrier and reel specifications on page 12.

GL06 SERIES — ECONOMY SURFACOIL® AIR CORE INDUCTORS

Inductance L (nH)	Standard Inductance Tolerance*	Model No.	Q min	Q/L Test Frequency (MHz)	ID (in/mm)	B (in/mm)	L (in/mm)	C (in/mm)	D (in/mm)
1.65	± 10%	GL06A01N6510	100	800	0.018/0.45	0.061/1.55	0.088/2.23	0.04/1.00	0.10/2.6
2.55	± 10%	GL06A02N5510	100	800	0.020/0.52	0.052/1.32	0.090/2.29	0.04/1.00	0.10/2.6
3.85	± 10%	GL06A03N8510	100	800	0.020/0.52	0.058/1.46	0.098/2.50	0.04/1.00	0.10/2.6
5.40	± 5%	GL06A05N4005	100	800	0.021/0.54	0.106/2.69	0.84/2.14	0.04/1.00	0.10/2.6
5.60	± 5%	GL06A05N6005	100	800	0.021/0.54	0.059/1.50	0.164/4.16	0.112/2.85	0.18/4.5
7.15	± 5%	GL06A07N1505	100	800	0.026/0.65	0.064/1.62	0.172/4.38	0.112/2.85	0.18/4.5
8.80	± 5%	GL06A08N8005	100	800	0.026/0.65	0.064/1.62	0.165/4.19	0.112/2.85	0.18/4.5
9.85	± 5%	GL06A09N8505	100	800	0.026/0.65	0.065/1.65	0.163/4.15	0.112/2.85	0.18/4.5
12.55	± 5%	GL06A12N5505	100	800	0.030/0.7	0.061/1.55	0.163/4.15	0.112/2.85	0.18/4.5

*Tighter tolerances are available, consult factory.

GL12 SERIES — ECONOMY SURFACOIL® AIR CORE INDUCTORS

Inductance L (nH)	Standard Inductance Tolerance*	Model No.	Q min	Q/L Test Frequency (MHz)	ID (in/mm)	B (in/mm)	L (in/mm)	C (in/mm)	D (in/mm)
2.5	± 10%	GL12A02N5010	100	150	0.053/1.35	0.091/2.3	0.11/2.9	0.065/1.65	0.17/4.2
5.0	± 10%	GL12A05N0010	100	150	0.053/1.35	0.082/2.1	0.135/3.45	0.065/1.65	0.17/4.2
8.0	± 10%	GL12A08N0010	100	150	0.061/1.55	0.10/2.6	0.15/3.7	0.065/1.65	0.17/4.2
12.5	± 10%	GL12A12N5010	100	150	0.060/1.53	0.11/2.7	0.2/4	0.065/1.65	0.17/4.2
18.5	± 10%	GL12A18N5010	100	150	0.061/1.55	0.10/2.6	0.135/3.45	0.065/1.65	0.17/4.2
17.5	± 10%	GL12A17N5010	100	150	0.061/1.55	0.11/2.7	0.25/6.4	0.19/4.7	0.29/7.3
22.5	± 5%	GL12A22N5005	100	150	0.061/1.55	0.11/2.7	0.27/6.8	0.19/4.7	0.29/7.3
28.0	± 5%	GL12A28N0005	100	150	0.061/1.55	0.11/2.7	0.26/6.6	0.19/4.7	0.29/7.3
35.5	± 5%	GL12A35N5005	100	150	0.061/1.55	0.11/2.8	0.24/6.2	0.19/4.7	0.29/7.3
43.0	± 5%	GL12A43N0005	100	150	0.061/1.55	0.11/2.8	0.26/6.6	0.19/4.7	0.29/7.3

*Tighter tolerances are available, consult factory.

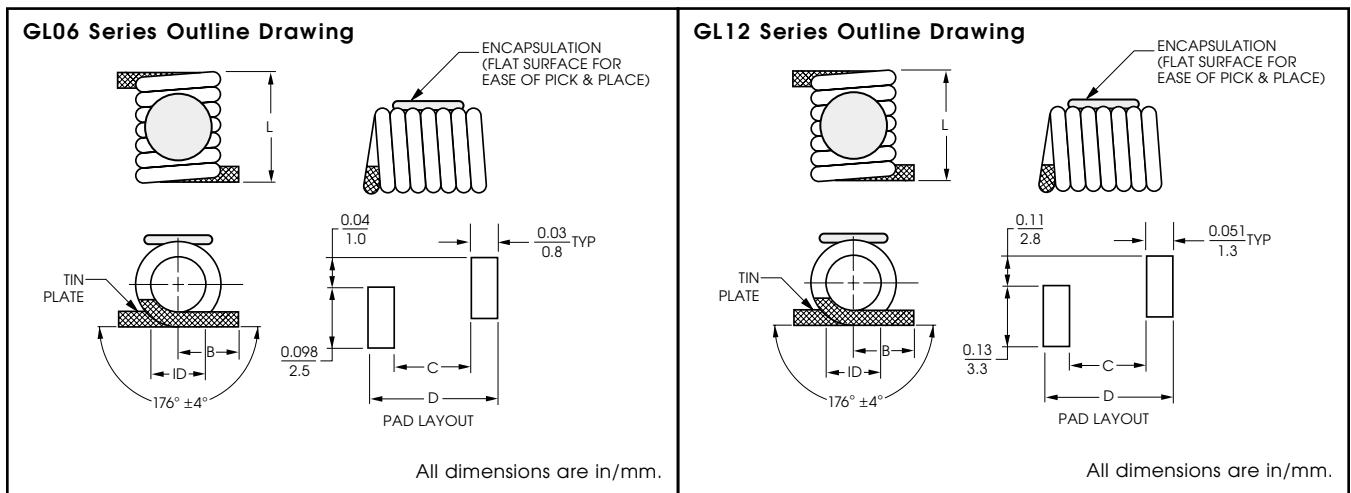

Carrier and reel specifications are on the web at www.spraguegoodman.com/800/800p1/html

GL15 SERIES — ECONOMY SURFCOIL® AIR CORE INDUCTORS

Inductance L (nH)	Standard Inductance Tolerance*	Model No.	Q min	Q/L Test Frequency (MHz)	ID (in/mm)	B (in/mm)	L (in/mm)
22.0	150	GL15A22N0005	100	150	0.096/2.45	0.1/3	0.2/5
27.0	150	GL15A27N0005	100	150	0.08/2.2	0.1/3	0.18/4.5
33.0	150	GL15A33N0005	100	150	0.096/2.45	0.1/3	0.21/5.3
39.0	150	GL15A39N0005	100	150	0.087/2.2	0.1/3	0.19/4.9
47.0	150	GL15A47N0005	100	150	0.098/2.5	0.11/2.8	0.19/4.8
56.0	150	GL15A56N0005	100	150	0.091/2.3	0.12/3.1	0.12/4.7
68.0	150	GL15A68N0005	100	150	0.100/2.55	0.11/2.8	0.17/4.4
82.0	150	GL15A82N0005	100	150	0.098/2.5	0.12/3.1	0.18/4.5
100.0	150	GL15AR100005	100	150	0.096/2.45	0.1/3	0.18/4.6
120.0	150	GL15AR120005	100	150	0.11/2.8	0.1/3	0.18/4.6

*Tighter tolerances are available, consult factory.

GL25 SERIES — ECONOMY SURFCOIL® AIR CORE INDUCTORS

Inductance L (nH)	Standard Inductance Tolerance*	Model No.	Q min	Q/L Test Frequency (MHz)	ID (in/mm)	B (in/mm)	L (in/mm)
90.0	50	GL25A90N0005	90	50	0.12/3.05	0.1/3	0.35/8.8
111.0	50	GL25AR1110005	90	50	0.12/3.05	0.1/3	0.35/8.8
130.0	50	GL25AR130005	90	50	0.12/3.05	0.11/2.9	0.34/8.6
150.0	50	GL25AR150005	90	50	0.128/3.25	0.1/3	0.33/8.4
169.0	50	GL25AR169005	90	50	0.128/3.25	0.1/3	0.33/8.4
206.0	50	GL25AR206005	90	50	0.128/3.25	0.1/3	0.3/8
222.0	50	GL25AR222005	90	50	0.128/3.25	0.13/3.3	0.33/8.5
246.0	50	GL25AR246005	90	50	0.128/3.25	0.14/3.5	0.4/9
307.0	50	GL25AR307005	90	50	0.13/3.4	0.13/3.3	0.34/8.6
380.0	50	GL25AR380005	90	50	0.14/3.5	0.12/3.1	0.33/8.4
422.0	50	GL25AR422005	90	50	0.14/3.6	0.12/3.1	0.33/8.5
491.0	50	GL25AR491005	90	50	0.14/3.6	0.124/3.15	0.33/8.5
538.0	50	GL25AR538005	90	50	0.144/0.365	0.1/3	0.34/8.6

*Tighter tolerances are available, consult factory.

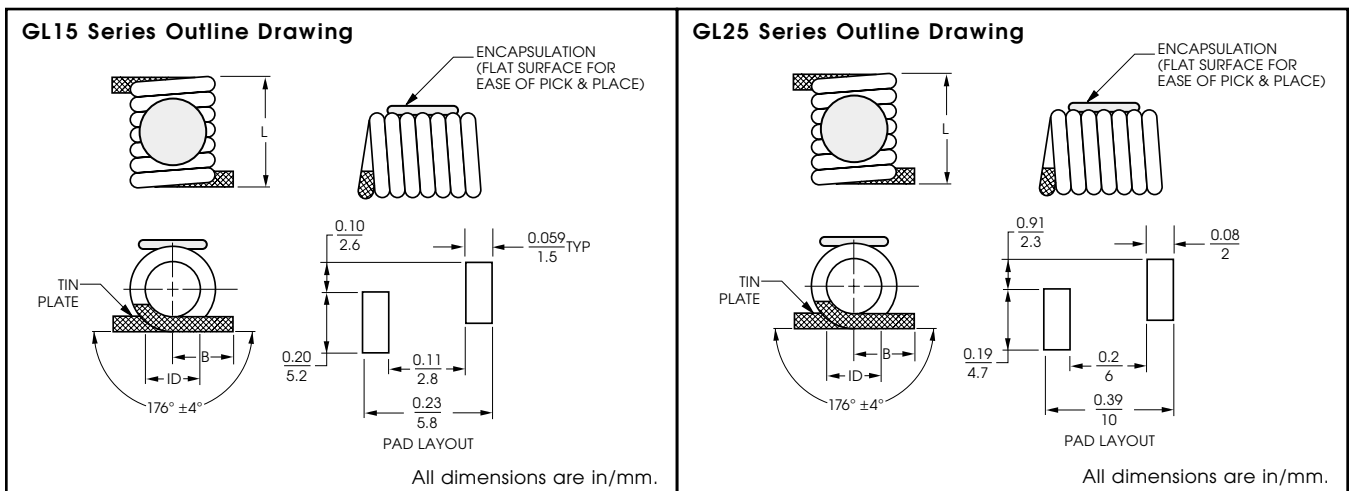

Carrier and reel specifications are on the web at www.spraguegoodman.com/800/800p1/html

CARRIER SPECIFICATIONS

Model Series	Dimension	A	B	C	D	E	F	G	H	K	L	M	N
	Tolerance	$\pm \frac{0.008}{0.2}$	$\pm \frac{0.008}{0.2}$	$\pm \frac{0.012}{0.3}$	$\pm \frac{0.002}{0.05}$	$\pm \frac{0.004}{0.1}$	$\pm \frac{0.004}{0.1}$	$\pm \frac{0.002}{0.05}$	$\pm \frac{0.004}{0.1}$	$\pm \frac{0.008}{0.2}$	$\pm \frac{0.002}{0.05}$	$\pm \frac{0.004}{0.1}$ -0	$\pm \frac{0.004}{0.1}$
GLA, GLAC, GLC, GLD		$\frac{0.11}{2.8}$	$\frac{0.14}{3.6}$	$\frac{0.31}{8.0}$	$\frac{0.14}{3.5}$	$\frac{0.069}{1.75}$	$\frac{0.16}{4.0}$	$\frac{0.079}{2.0}$	$\frac{0.16}{4.0}$	$\frac{0.091}{2.3}$	$\frac{0.01}{0.3}$	$\frac{0.059}{1.5}$	—
GLB, GLBP		$\frac{0.14}{3.6}$	$\frac{0.19}{4.9}$	$\frac{0.472}{12.0}$	$\frac{0.22}{5.5}$	$\frac{0.069}{1.75}$	$\frac{0.31}{8.0}$	$\frac{0.079}{2.0}$	$\frac{0.16}{4.0}$	$\frac{0.13}{3.4}$	$\frac{0.01}{0.3}$	$\frac{0.059}{1.5}$	—
GLU, GLW		$\frac{0.095}{2.4}$	$\frac{0.11}{2.9}$	$\frac{0.31}{8.0}$	$\frac{0.14}{3.5}$	$\frac{0.069}{1.75}$	$\frac{0.16}{4.0}$	$\frac{0.079}{2.0}$	$\frac{0.16}{4.0}$	$\frac{0.073}{1.85}$	$\frac{0.01}{0.3}$	$\frac{0.059}{1.5}$	$\frac{0.043}{1.1}$
GLX		$\frac{0.057}{1.45}$	$\frac{0.089}{2.25}$	$\frac{0.31}{8.0}$	$\frac{0.14}{3.5}$	$\frac{0.069}{1.75}$	$\frac{0.16}{4.0}$	$\frac{0.079}{2.0}$	$\frac{0.16}{4.0}$	$\frac{0.055}{1.4}$	$\frac{0.0098}{0.25}$	$\frac{0.059}{1.5}$	$\frac{0.043}{1.1}$
GLY, GLYC		$\frac{0.039}{1.0}$	$\frac{0.071}{1.8}$	$\frac{0.31}{8.0}$	$\frac{0.14}{3.5}$	$\frac{0.069}{1.75}$	$\frac{0.16}{4.0}$	$\frac{0.079}{2.0}$	$\frac{0.16}{4.0}$	$\frac{0.039}{1.0}$	$\frac{0.0098}{0.25}$	$\frac{0.059}{1.5}$	—
GLZ, GLZB, GLZP		$\frac{0.028}{0.71}$	$\frac{0.048}{1.21}$	$\frac{0.31}{8.0}$	$\frac{0.14}{3.5}$	$\frac{0.069}{1.75}$	$\frac{0.16}{4.0}$	$\frac{0.079}{2.0}$	$\frac{0.16}{4.0}$	—	—	—	—

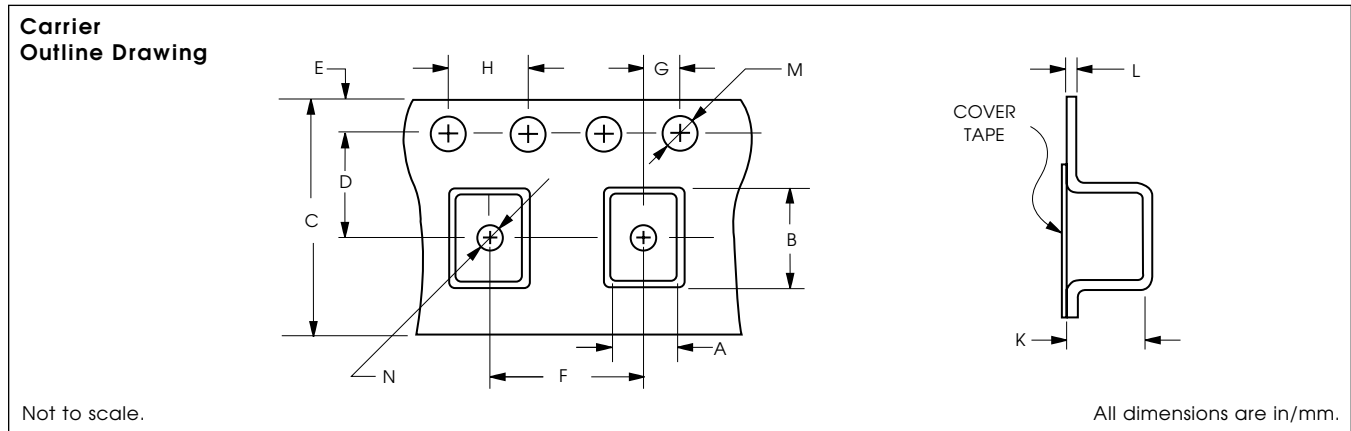

REEL SPECIFICATIONS

Model Series	Dimension	Qty	A	B	C	D	E	T	W
	Tolerance	—	$\pm \frac{0.079}{2.0}$	$\pm \frac{0.02}{0.5}$	$\pm \frac{0.02}{0.5}$	$\pm \frac{0.03}{0.8}$	$\pm \frac{0.02}{0.5}$	$\pm \frac{0.02}{0.5}$	$\pm \frac{0.01}{0.3}$
GLA, GLAC, GLC, GLD, GLU, GLW		2,000	$\frac{7.01}{178}$	$\frac{2.4}{60}$	$\frac{0.51}{13}$	$\frac{0.83}{21}$	$\frac{0.079}{2.0}$	$\frac{0.043}{1.1}$	$\frac{0.35}{9.0}$
GLX, GLY, GLYC		3,000	$\frac{7.01}{178}$	$\frac{2.4}{60}$	$\frac{0.51}{13}$	$\frac{0.83}{21}$	$\frac{0.079}{2.0}$	$\frac{0.043}{1.1}$	$\frac{0.35}{9.0}$
GLB, GLBP		500	$\frac{7.01}{178}$	$\frac{2.4}{60}$	$\frac{0.51}{13}$	$\frac{0.83}{21}$	$\frac{0.079}{2.0}$	$\frac{0.043}{1.1}$	$\frac{0.51}{13}$
GLZ, GLZB, GLZP		10,000	$\frac{7.01}{178}$	$\frac{2.4}{60}$	$\frac{0.51}{13}$	$\frac{0.83}{21}$	$\frac{0.079}{2.0}$	$\frac{0.043}{1.1}$	$\frac{0.35}{9.0}$

Reel Outline Drawing

Not to scale. All dimensions are in/mm.