

## MICA DIELECTRIC COMPRESSION TRIMMER CAPACITORS

### FEATURES

- Very large capacitance ranges
- High Q
- Good RF current handling capability
- Many forms and mounting styles



### SPECIFICATIONS

**Operating Temperature Range:** -35°C to +85°C

**Maximum Capacitance:** When set at the tight position (tight defined as 28 oz-in/2.0 kg-cm), the maximum capacitance will be no less than the value indicated in the table.

**Minimum Capacitance:** When adjusting screw is rotated 3 turns from tight position (2 turns for types 1, 5, and 9), the minimum capacitance will be no greater than the value indicated in the table.

Voltage:	Working (VDC)	Dielectric Withstanding (VDC)
Type 1	250	500
Types 2, 3, 4	175	350
Type 5	500	1000
Types 6, 7, 8	250	500
Type 9	2000	2700

**Insulation Resistance:** 100,000 megohms min at 25°C

**Q:** Minimum Q at 1 MHz per graph (for units which have nominal maximum capacitance ≤ 1000 pF).

**Dissipation Factor:** Maximum DF = 0.004 at 1 kHz (for units which have nominal maximum capacitance > 1000 pF).

**Capacitance change with temperature** (capacitor set at 1/4 to 1/2 turn from the tight position):

$$\begin{aligned} \text{Types 1, 5, 9} &= \pm (2.5\% + 0.3 \text{ pF}) \\ \text{Types 2, 3, 4, 6, 7, 8} &= \pm (1.5\% + 0.3 \text{ pF}) \end{aligned}$$

**Capacitance drift with temperature** (capacitor set at 1/4 to 1/2 turn from the tight position):

$$\begin{aligned} \text{Types 1, 5, 9} &= \pm (2.0\% + 0.5 \text{ pF}) \\ \text{Types 2, 3, 4, 6, 7, 8} &= \pm (1.5\% + 0.5 \text{ pF}) \end{aligned}$$

**Q vs Capacitance**  
(1 MHz)

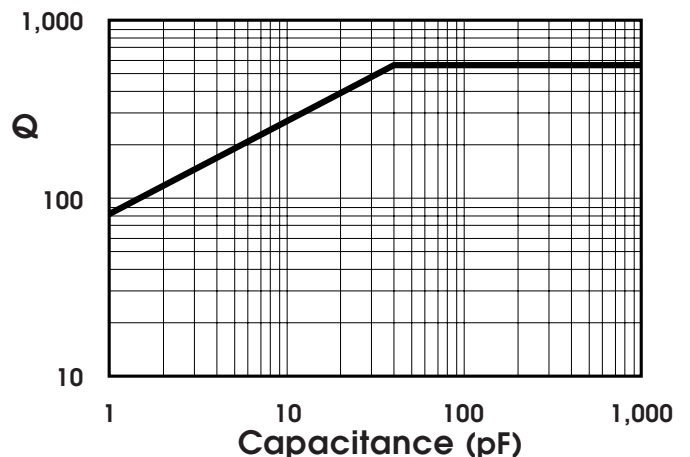

**Sprague-Goodman Electronics, Inc.**

1700 SHAMES DRIVE, WESTBURY, NY 11590  
 TEL: 516-334-8700 • FAX: 516-334-8771  
 E-MAIL: info@spraguegoodman.com

## PART NUMBERING SYSTEM

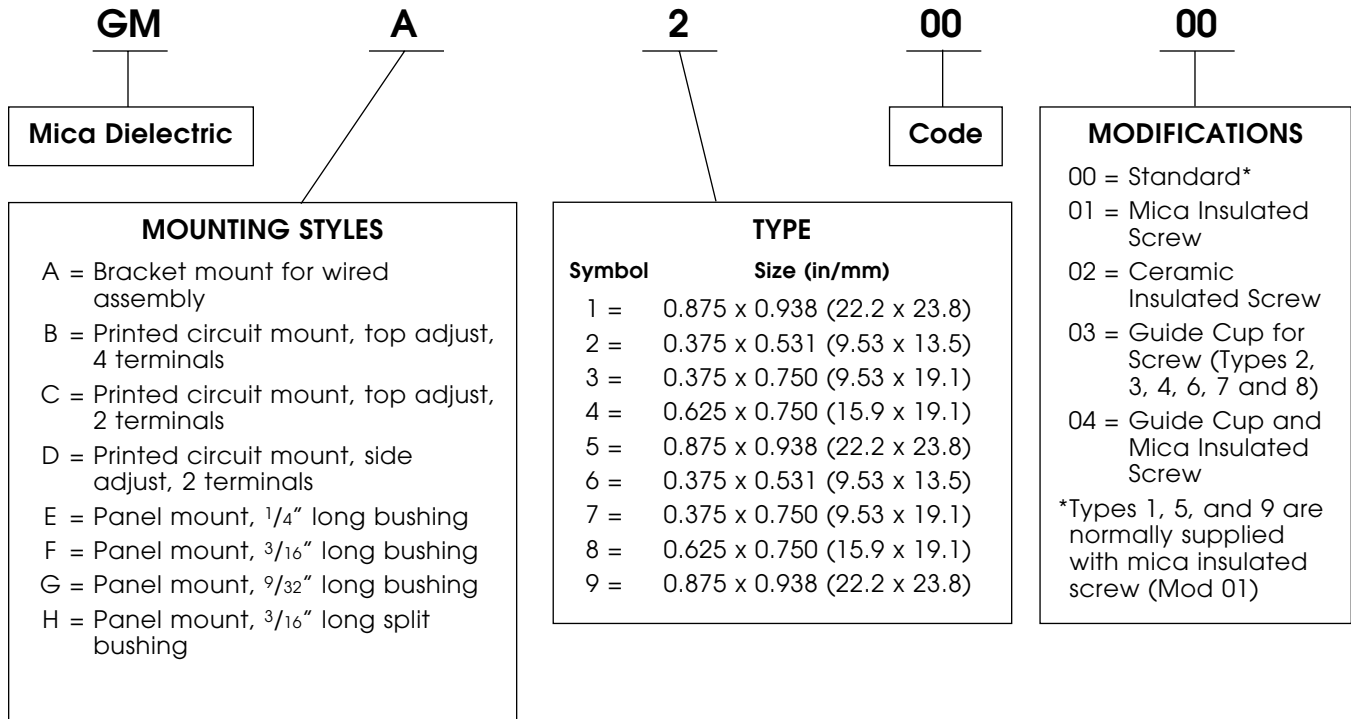

- MOUNTING STYLES**
- A = Bracket mount for wired assembly
  - B = Printed circuit mount, top adjust, 4 terminals
  - C = Printed circuit mount, top adjust, 2 terminals
  - D = Printed circuit mount, side adjust, 2 terminals
  - E = Panel mount, 1/4" long bushing
  - F = Panel mount, 3/16" long bushing
  - G = Panel mount, 9/32" long bushing
  - H = Panel mount, 3/16" long split bushing

**TYPE**

Symbol	Size (in/mm)
1 =	0.875 x 0.938 (22.2 x 23.8)
2 =	0.375 x 0.531 (9.53 x 13.5)
3 =	0.375 x 0.750 (9.53 x 19.1)
4 =	0.625 x 0.750 (15.9 x 19.1)
5 =	0.875 x 0.938 (22.2 x 23.8)
6 =	0.375 x 0.531 (9.53 x 13.5)
7 =	0.375 x 0.750 (9.53 x 19.1)
8 =	0.625 x 0.750 (15.9 x 19.1)
9 =	0.875 x 0.938 (22.2 x 23.8)

- MODIFICATIONS**
- 00 = Standard\*
  - 01 = Mica Insulated Screw
  - 02 = Ceramic Insulated Screw
  - 03 = Guide Cup for Screw (Types 2, 3, 4, 6, 7 and 8)
  - 04 = Guide Cup and Mica Insulated Screw
- \*Types 1, 5, and 9 are normally supplied with mica insulated screw (Mod 01)

### Types 2 and 6

Capacitance Range (pF)		Model No. <sup>1</sup>
min	max	
2.5	7	GM_20000
4	20	GM_20200
8	45	GM_20300
12	65	GM_20400
16	90	GM_20500
25	115	GM_20600
55	285	GM_20700
90	340	GM_20800

<sup>1</sup> Insert letter A, B, C, or D in blank space for mounting style required.  
 For type 6, substitute 6 for 2 in the fourth character of the catalog number.  
 Example: GMA20200 becomes GMA60200

### Types 3 and 7

Capacitance Range (pF)		Model No. <sup>2</sup>
min	max	
2.5	12	GM_30000
3.5	25	GM_30100
7.0	40	GM_30200
16.0	100	GM_30300
25.0	150	GM_30400
40.0	200	GM_30500
56.0	250	GM_30600
75.0	300	GM_30700
95.0	350	GM_30800
115.0	400	GM_30900
130.0	450	GM_31000
150.0	500	GM_31100
170.0	550	GM_31200
200.0	600	GM_31300
220.0	650	GM_31400
240.0	700	GM_31500

<sup>2</sup> Insert letter A, B, C, or D in blank space for mounting style required.  
 For type 7, substitute 7 for 3 in the fourth character of the catalog number.  
 Example: GMA30200 becomes GMA70200

### Types 4 and 8

Capacitance Range (pF)		Model No. <sup>3</sup>
min	max	
3	15	GM_40000
5	30	GM_40100
10	80	GM_40200
20	180	GM_40300
45	280	GM_40400
75	380	GM_40500
105	480	GM_40600
140	580	GM_40700
175	680	GM_40800
215	790	GM_40900
260	900	GM_41000
300	1000	GM_41100
330	1100	GM_41200
360	1200	GM_41300
380	1300	GM_41400
420	1400	GM_41500

<sup>3</sup> Insert letter A, B, C, or D in blank space for mounting style required.  
 For type 8, substitute 8 for 4 in the fourth character of the catalog number.  
 Example: GMA40200 becomes GMA80200

## SPRAGUE-GOODMAN MICA DIELECTRIC TRIMMER CAPACITORS TYPES 2, 3 and 4 (175 WVDC) TYPES 6, 7 and 8 (250 WVDC)

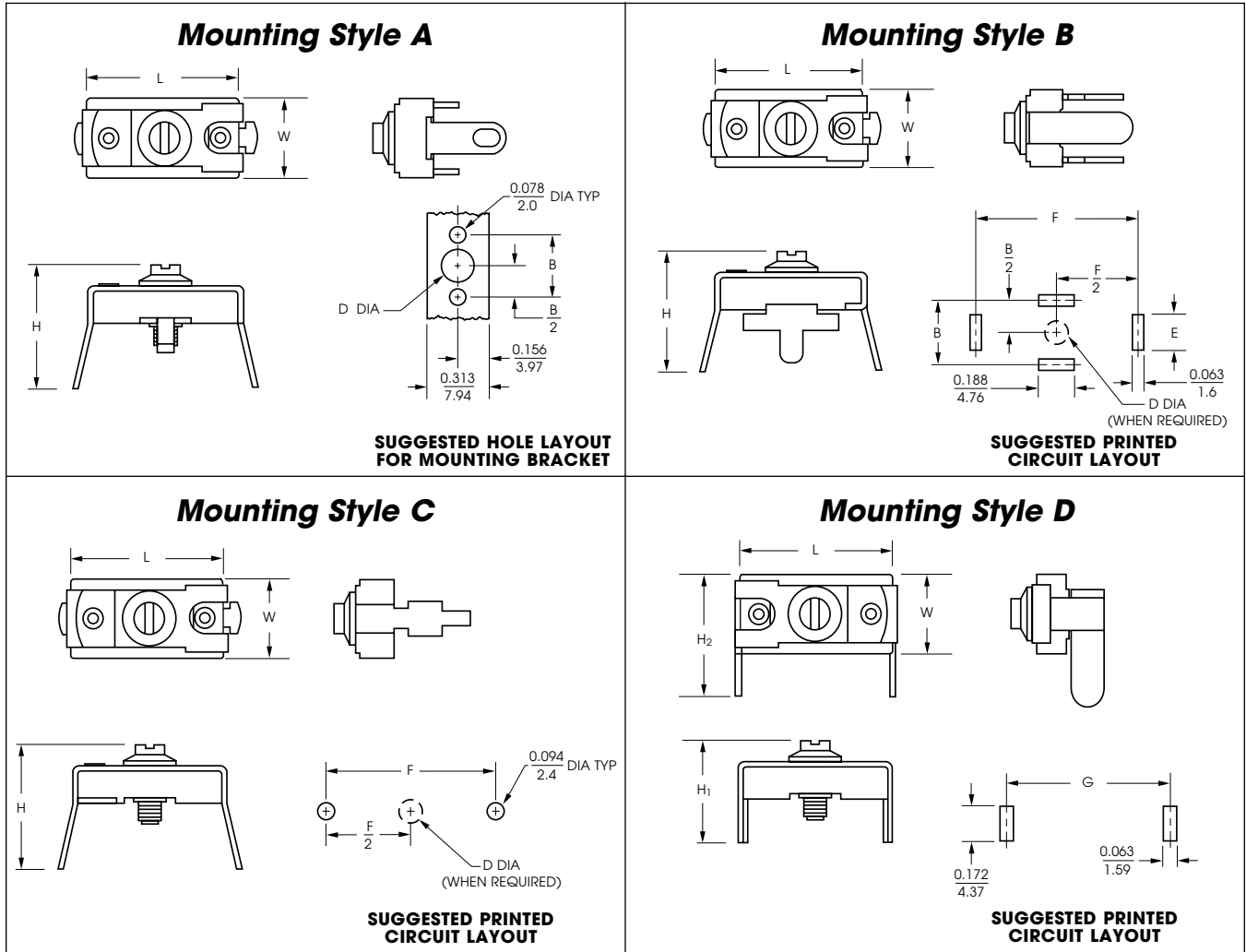

Type	L	W	H	H <sub>1</sub>	H <sub>2</sub>	B	D	E	F	G
2 & 6	$\frac{0.531}{13.5}$	$\frac{0.375}{9.53}$	$\frac{0.719}{18.3}$	$\frac{0.563}{14.3}$	$\frac{0.719}{18.3}$	$\frac{0.315}{8.00}$	$\frac{0.175}{4.45}$	$\frac{0.188}{4.76}$	$\frac{0.563}{14.3}$	$\frac{0.594}{15.1}$
3 & 7	$\frac{0.750}{19.1}$	$\frac{0.375}{9.53}$	$\frac{0.781}{19.8}$	$\frac{0.625}{15.9}$	$\frac{0.625}{15.9}$	$\frac{0.315}{8.00}$	$\frac{0.175}{4.45}$	$\frac{0.188}{4.76}$	$\frac{0.813}{20.6}$	$\frac{0.781}{19.8}$
4 & 8	$\frac{0.750}{19.1}$	$\frac{0.625}{15.9}$	$\frac{0.781}{19.8}$	$\frac{0.563}{14.3}$	$\frac{0.969}{24.6}$	$\frac{0.546}{13.9}$	$\frac{0.206}{5.23}$	$\frac{0.281}{7.14}$	$\frac{0.813}{20.6}$	$\frac{0.813}{20.6}$

Dimensions are in/mm.

# SPRAGUE-GOODMAN MICA DIELECTRIC TRIMMER CAPACITORS TYPES 1, 5 and 9

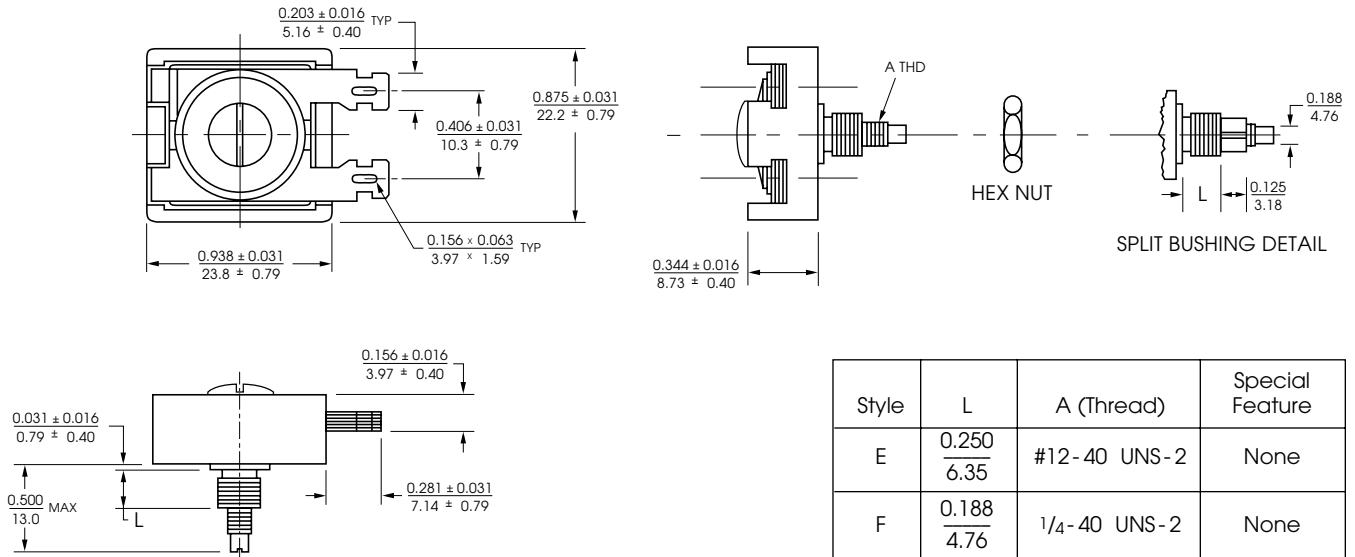

Style	L	A (Thread)	Special Feature
E	$\frac{0.250}{6.35}$	#12-40 UNS-2	None
F	$\frac{0.188}{4.76}$	1/4-40 UNS-2	None
G	$\frac{0.281}{7.14}$	1/4-40 UNS-2	None
H	$\frac{0.188}{4.76}$	1/4-40 UNS-2	Split Bushing

Dimensions are in/mm.

## Type 1

Working Voltage: 250 VDC		Model No. <sup>4</sup>
Test Voltage: 500 VDC		
Capacitance Range (pF)		Model No. <sup>4</sup>
min	max	
15	130	GM__10201
65	340	GM__10301
115	550	GM__10401
190	760	GM__10501
275	970	GM__10601
350	1180	GM__10701
450	1390	GM__10801
550	1600	GM__10901
650	1890	GM__11001
780	2110	GM__11101
880	2330	GM__11201
1150	2605	GM__11301
1300	2830	GM__11401
1400	3055	GM__11501

## Type 5

Working Voltage: 500 VDC		Model No. <sup>4</sup>
Test Voltage: 1000 VDC		
Capacitance Range (pF)		Model No. <sup>4</sup>
min	max	
15	120	GM__50201
65	320	GM__50301
100	500	GM__50401
180	690	GM__50501
265	880	GM__50601
340	1070	GM__50701
425	1260	GM__50801
525	1415	GM__50901
615	1600	GM__51001
730	1785	GM__51101
800	1970	GM__51201
1000	2155	GM__51301
1100	2340	GM__51401
1200	2525	GM__51501

## Type 9

Working Voltage: 2000 VDC		Model No. <sup>4</sup>
Test Voltage: 2700 VDC		
Capacitance Range (pF)		Model No. <sup>4</sup>
min	max	
10	48	GM__90201
45	105	GM__90301
70	160	GM__90401
95	230	GM__90501
100	270	GM__90601
170	350	GM__90701
190	380	GM__90801
250	480	GM__90901

<sup>4</sup> Insert letter E, F, G or H in blank space for mounting style (Style H not available in Type 9). Model numbers are shown with the "01" modification, calling for a mica insulated screw, which is the way types 1, 5, and 9 are normally supplied.