



ZD3213

600mA Regulated Charge Pump for White LEDs



Features

- Input Supply Voltage from 2.9V to 5V
- 600mA Output Current
- Low Noise, Variable Frequency Operation
- Super Low Quiescent current of typical 500 μ A.
- 3 Levels of Regulated Output
- 2-Bit Control For Torch, Red-Eye and Flash Mode Function
- Regulated Output Voltage or Current
- 2 Phase, 2X Charge Pump For High Efficiency
- Automatic Soft-Start limits Inrush Current
- Internal Thermal Shutdown
- No Inductors
- $I_{cc} < 1\mu$ A in Shutdown
- Available in 10-Pin MSOP Green Packages
- Enhanced Output Current of 800mA (ZD3215) Versions Available

Applications

- White LED Flash/Torch for Cellular Phones
- Digital Cameras, Camcorders and GPS Receivers
- General Lighting, Flash, or Strobe Applications
- LCD Module Backlighting
- Programmable DC/DC Boost Converter

Pin Configuration

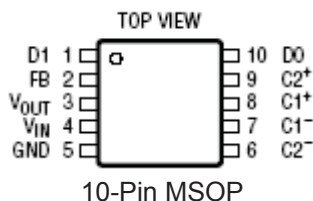

General Description

The ZD3213 is a low noise, super low quiescent current, regulated charge pump DC/DC converter that uses 2 phase conversion for high power output applications such as flash and torch White LED applications. The part can be used to produce a regulated voltage or current of up to 600mA from a 2.9V to 5V input. Low external parts count make the ZD3213 ideally suited for small, battery-powered applications.

An internal 2-bit DAC allows LED current to be adjusted for LED brightness control. The ZD3213 also has thermal shutdown protection and can survive a continuous short-circuit from V_{out} to GND. High switching frequency enables the use of small external capacitors. A low current shutdown feature disconnects the load from V_{in} and reduces quiescent current to less than 1 μ A.

The ZD3213 is available in a 10-pin MSOP Green Package.

Ordering Information

Part Number	Temperature Range	Package Type
ZD3213LEU	-40°C to +85°C	10-Pin MSOP
ZD3213EVB	n/a	Evaluation Board

Please contact the factory for pricing and availability on Tape-on-Reel and Green Package option.

Typical Application

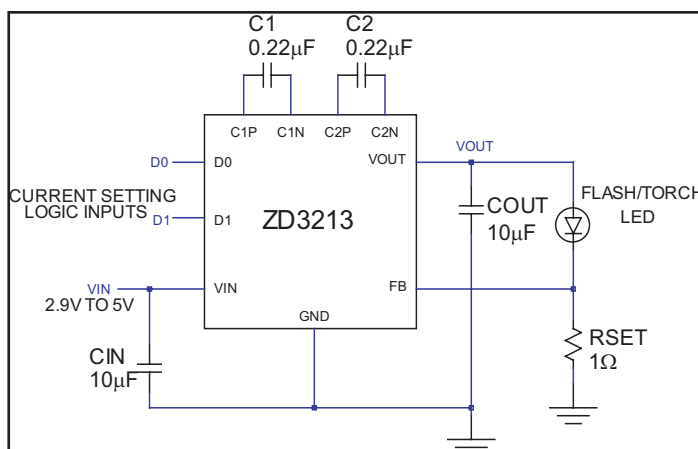

Current Setting Logic Inputs Truth Table

D1	D0	Mode ($R_{SET}=1.0\Omega$)
0	0	Shutdown
0	1	250mA (Torch)
1	0	500mA (Red-Eye)
1	1	600mA (Flash)

Specifications subject to change without notice



Absolute Maximum Ratings

These are stress ratings only and functional operation of the device at these ratings or any other above those indicated in the operation sections of the specifications is not implied. Exposure to absolute maximum rating conditions for extended periods of time may affect reliability.

V_{IN} , V_{OUT} to GND	-0.3V to 6V
D0, D1	-0.3V to $V_{IN} + 0.3V$
V_{OUT} Short-Circuit Duration	Indefinite
Operation Temperature Range	-40°C to +85°C
Storage Temperature	-65°C to +150°C
Lead Temperature (Soldering, 10 sec.)	300°C

Power Dissipation Per Package	
10-pin MSOP Thermal Resistance (θ_{JA}) 157°C/W

Note 1: Based on long-term current density limitations

Note 2: The ZD3213 is guaranteed to meet performance specifications from -40°C to 85°C.

Storage Considerations

Storage in a low humidity environment is preferred. Large high density plastic packages are moisture sensitive and should be stored in Dry Vapor Barrier Bags. Prior to usage, the parts should remain bagged and stored below 40°C and 60%RH. If the parts are removed from the bag, they should be used within 168 hours or stored in an environment at or below 20%RH. If the above conditions cannot be followed, the parts should be baked for 12 hours at 125°C in order to remove moisture prior to soldering. Zywyn ships product in Dry Vapor Barrier Bags with a humidity indicator card and desiccant pack. The humidity indicator should be below 30%RH. The MSL of this product is 3.

The information furnished by Zywyn has been carefully reviewed for accuracy and reliability. Its application or use, however, is solely the responsibility of the user. No responsibility of the use of this information become part of the terms and conditions of any subsequent sales agreement with Zywyn. Specifications are subject to change without no responsibility for any infringement of patents or other rights of third parties which may result from its use. No license or proprietary rights are granted by implication or otherwise under any patent or patent rights of Zywyn Corporation.

Electrical Characteristics

Specifications are at $T_A = 25^\circ\text{C}$. $V_{IN} = 3.6\text{V}$, $C_1=C_2=0.22\mu\text{F}$, $C_{OUT}=C_{IN}=10\mu\text{F}$; unless otherwise noted.

Parameter	Condition	Min	Typ	Max	Units
Input Power Supply V_{IN} Operating Voltage I_{CC} Operating Current I_{SHDNB} Shutdown Current I_{FB}	$I_{OUT} = 0\text{mA}$, $V_{IN} = D0 = D1 = 3.6\text{V}$ $D1 = D0 = 0\text{V}$ $V_{FB} = 0.8\text{V}$	2.9	0.5	5.0 1 1	V mA μA nA
Torch Mode I_{OUT} V_{FB}	$D1=0\text{V}$, $D0=V_{IN}$; $2.9\text{V} \leq V_{IN} \leq 4.5\text{V}$; $R_{SET}=1.0\Omega$ $D1=0\text{V}$, $D0=V_{IN}$; $2.9\text{V} \leq V_{IN} \leq 4.5\text{V}$; $I_{OUT}=10\text{mA}$	180	250 230	280	mA mV
Red-Eye Mode I_{OUT} V_{FB}	$D1=V_{IN}$, $D0=0\text{V}$; $V_{IN}=3.3\text{V}$; $RSET=1.0\Omega$; Pulse Width=50ms~300ms; 1Hz max $D1=V_{IN}$, $D0=0\text{V}$; $I_{OUT}=10\text{mA}$	380	500 450	530	mA mV
Flash Mode I_{OUT} V_{FB}	$D1=D0=V_{IN}$; $V_{IN}=3.6\text{V}$; $RSET=1.0\Omega$; Pulse Width=50ms~300ms; 1Hz max $D1=D0=V_{IN}$; $I_{OUT}=10\text{mA}$	500	600 600	700	mA mV
Charge Pump Efficiency	$D1=0\text{V}$, $D0=V_{IN}$; $V_{IN}=3.0\text{V}$; $I_{OUT}=200\text{mA}$		65		%
Data Input, D0, D1 High Level Input Voltage (V_{IH}) Low Level Input Voltage (V_{IL}) Input Current (I_{IH}) Input Current (I_{IL})	$V_{IN}=3.6\text{V}$; $V_{IN}=3.6\text{V}$; $D1 = D0 = V_{IN}$ $D1 = D0 = 0\text{V}$	1.5 -1 -1		0.4 1 1	V V μA μA

Current Setting D1, D0 Truth Table

D1	D0	Mode	Application
0	0	Shutdown	Power Down
0	1	250mA	Torch Function
1	0	500mA	Red-Eye Function
1	1	600mA	Flash Function

Based on feedback resistor R_{SET} of 1.0Ω with rating at 0.5W .

Block Diagram

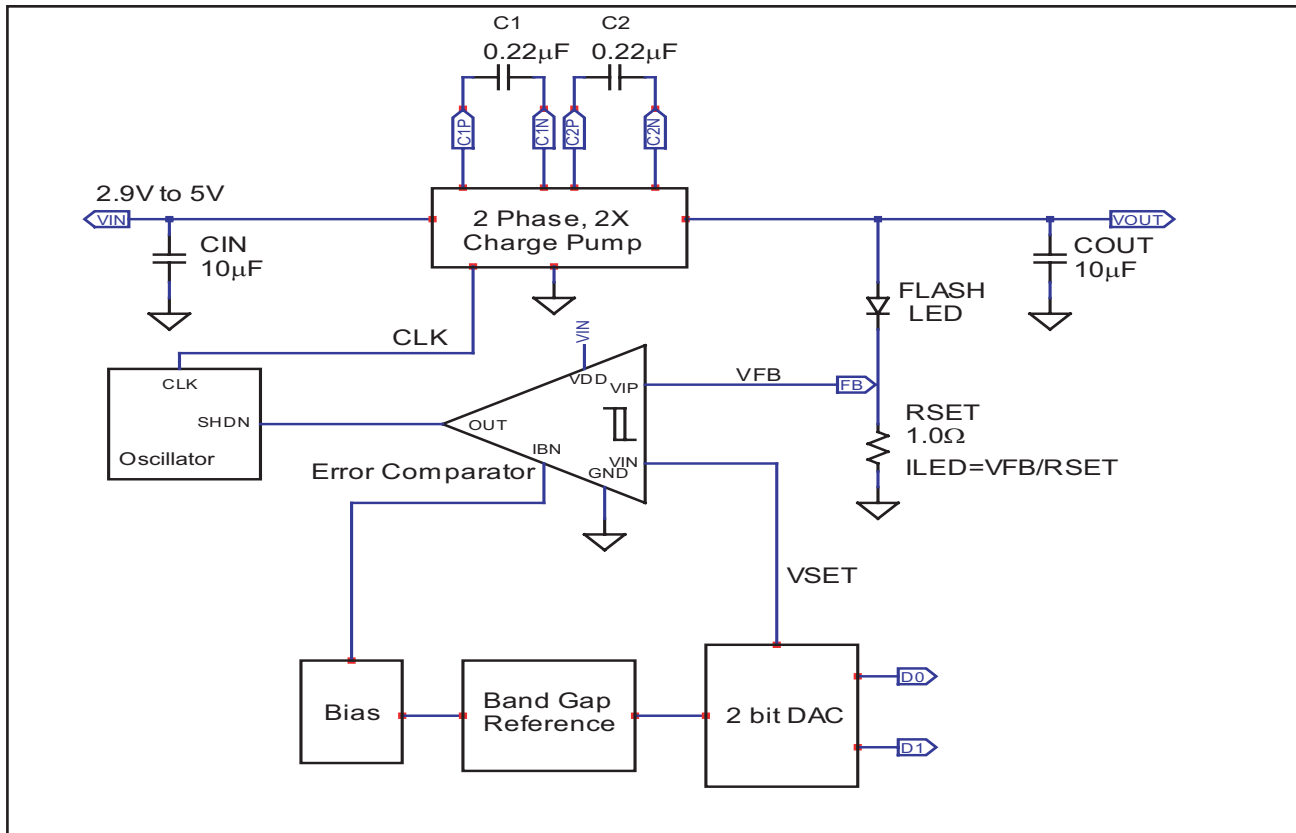

Block diagram of ZD3213 high power flash LED driver with external components

Pin Description

Pin Name	Pin Number	Pin Function
D1, D0	1, 10	Control Inputs. D0 and D1 determines either torch, red-eye, or flash setting
FB	2	Feedback Pin. Input for the regulation contro loop. LED current is equal to VFB / RSET
VOUT	3	VOUT is the output of the charge pump. A low ESR, 10µF ceramic capacitor is required from VOUT to GND
VIN	4	Input Supply Voltage. VIN should be bypassed with a 10µF low ESR ceramic capacitor
GND	5	Ground Pin for the charge pump and control circuitry. This pin should be connected directly to a low impedance local ground plane.
C2-, C1-, C1+, C2+	6. 7. 8. 9	Charge Pump Flying Capacitor Pins. A 0.22µF, low ESR ceramic capacitor should be connected from C1+ to C1- and from C2+ to C2-.

Circuit Description

The ZD3213 uses a state-of-the-art switched capacitor, fractional conversion, charge pump to boost V_{OUT} by as much as twice the input voltage. The charge pump switches are driven by a two-phase, non-overlapping clock that assures low EMI designs. The two-phase clock alternately charges the flying capacitors and boosts the output voltage with a variable frequency.

Adjustable, Regulated Output

Regulation is provided by a feedback loop from the FB pin to the charge pump modulator, resulting in stable output voltages over the devices wide operating range. The regulated output can be adjusted with the control pins, D0 and D1. The ZD3213 integrates a digital-to-analog converter to allow dynamic, digital control of the regulated voltage. Table 1 shows the feedback Set Point Voltage as a function of D0 and D1.

D1	D0	Operation Mode	Output ($R_{SET}=1.0\Omega$)
0	0	Shutdown	0mA
0	1	Torch Application	250mA
1	0	Red-Eye Application	500mA
1	1	Flash Application	600mA

Table 1. Feedback Control Voltage Settings

Controlled Power-Down

The ZD3213 has a low-power shutdown mode controlled by the control pins, D0 and D1. When both control pins are held at a low logic level, the ZD3213 enters power down mode and draws only leakage current from the V_{IN} supply. All internal circuitry is disabled and V_{OUT} is disconnected from V_{IN} . D0 and D1 control inputs are high impedance CMOS inputs and should not be left floating. Ensure that they are always driven with valid logic levels.

Shutdown Current

When the ZD3213 is placed in shutdown mode and while the V_{OUT} is still at a positive voltage, regulators feedback circuit will draw $5\mu A$ of current. To minimize the current draw, a bleed resistor of $10k\Omega$ to $100k\Omega$ can be used to draw down V_{OUT} during shutdown.

Voltage or Current Programming of the ZD3213

The ZD3213 is configurable to regulate either voltage or current. In white LED applications, the ratio of the feedback set point and a sense resistor controls the current through the white LED, as shown in Figure 1

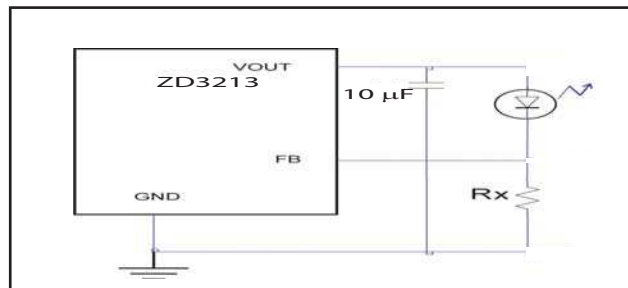

Figure 1 Current Control Mode

This configuration requires the largest amount of output capacitance to maintain stability, due to the high loop gain caused by relatively low impedance of the white LED as compared to the sense resistor.

In constant voltage applications. The output voltage is set by the ratio of two resistors and the feedback set point, as shown in Figure 2. $V_{OUT} = \text{set point voltage} * (1 + R1/R2)$. The closed-loop output resistance is impacted by the resistor ratio $R1:R2$, the higher the ratio, the higher the output resistance. The output resistance is 0.35Ω with a nominal gain of 1. Typically the total resistance of the voltage divider, $R1:R2$, will be in the range of several $k\Omega$ to $1M\Omega$.

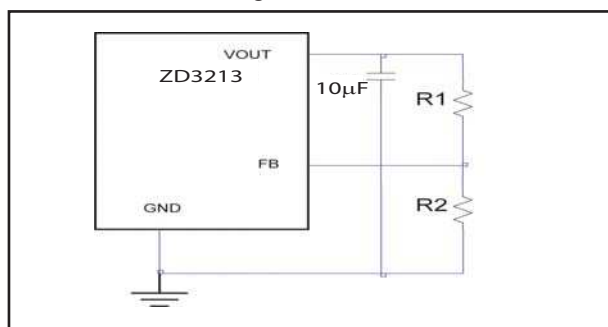
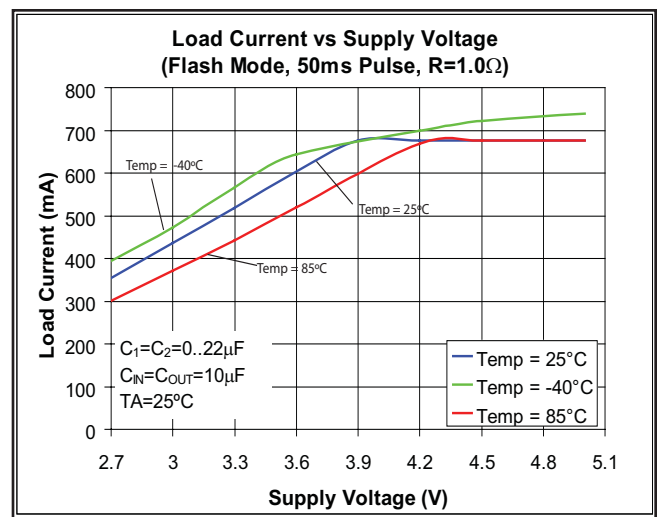
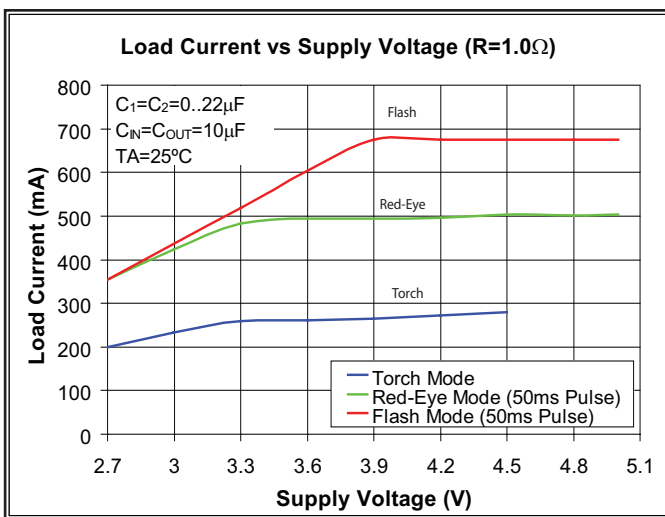
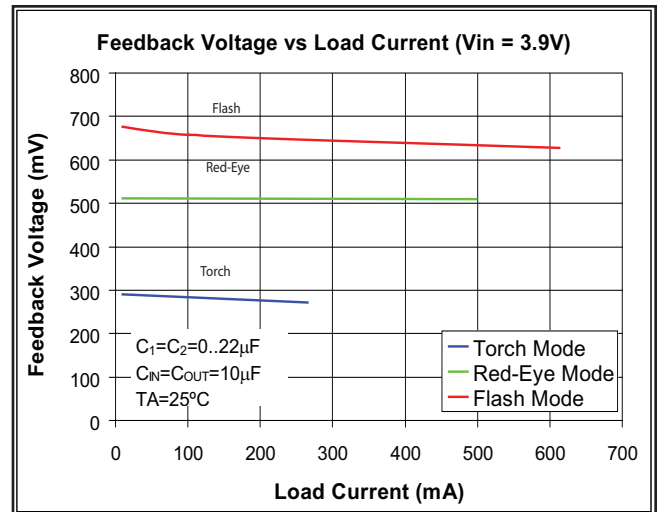
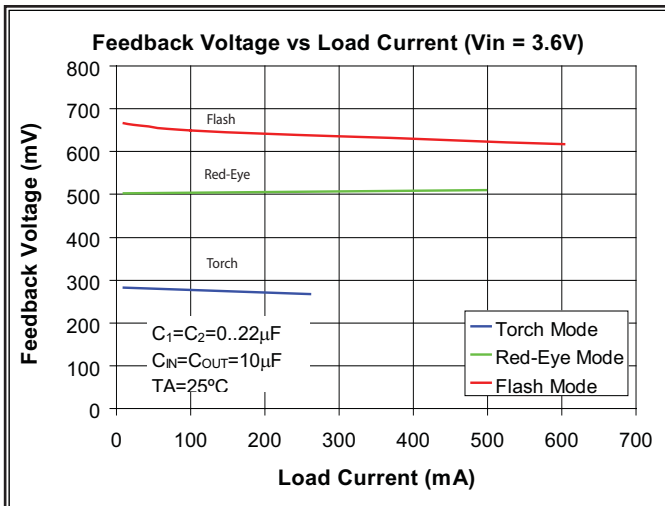
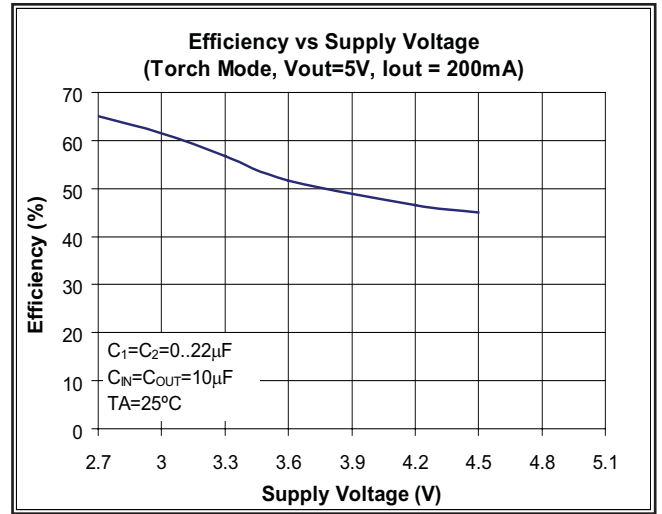
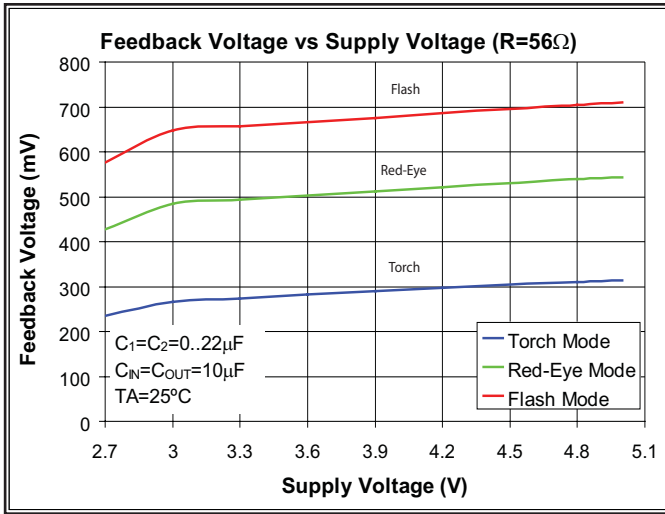
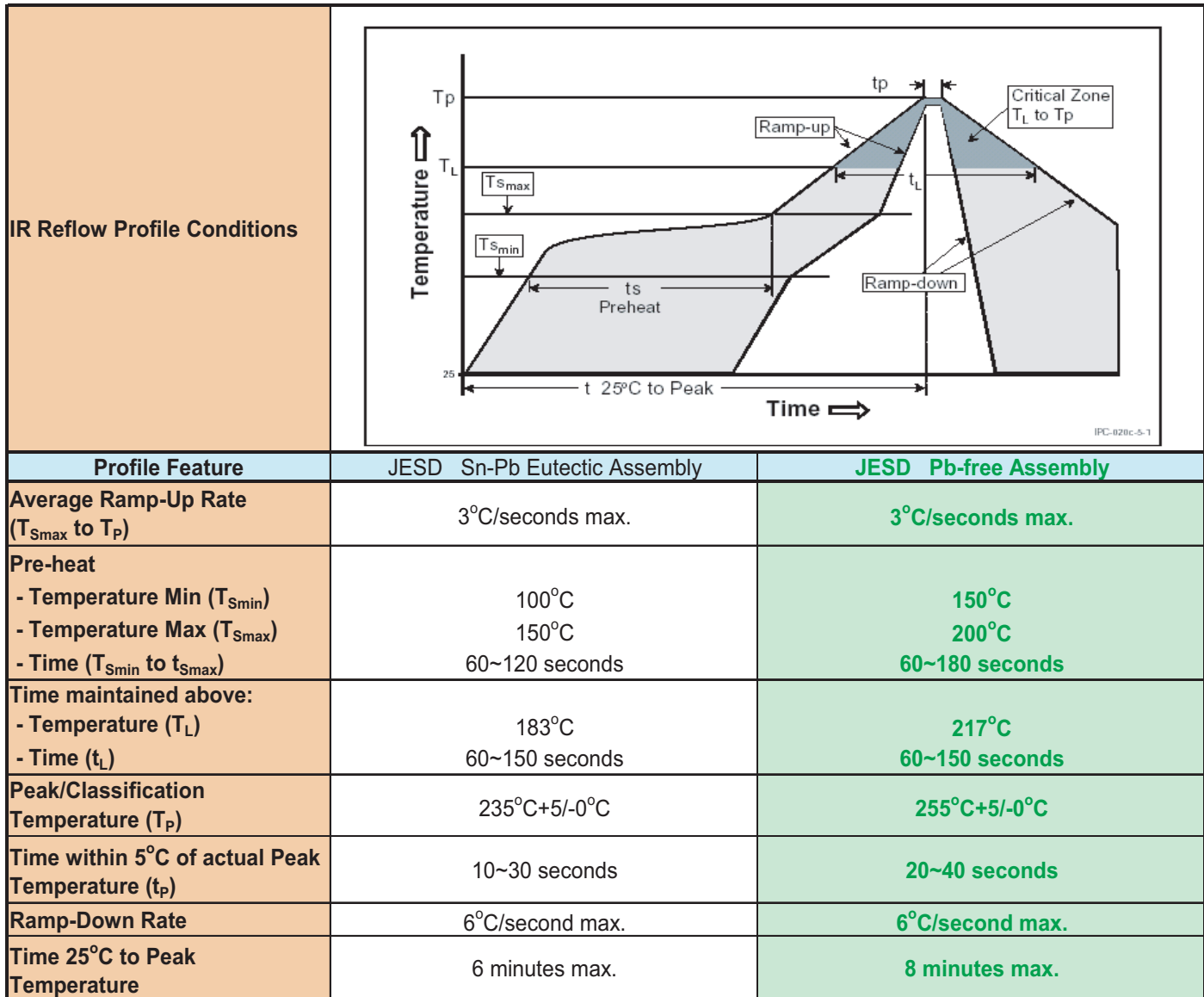

Figure 2. Voltage Control Mode

Typical Performance Characteristics



Green Package SMD IR Reflow Profile Information



Zywyn Green Packages are Pb-free and RoHS compliance.

Package Information

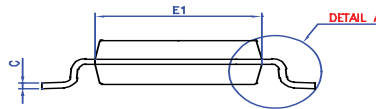
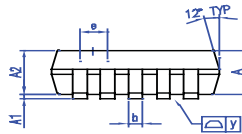
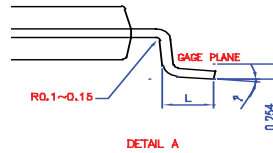
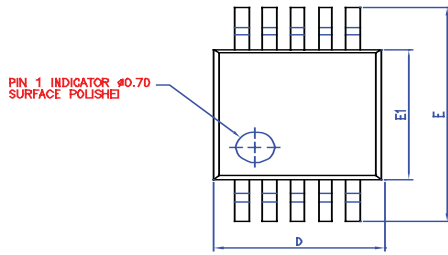

- ▲ NOTE :
1. CONTROLLING DIMENSION : mm
 2. LEAD FRAME MATERIAL : OLIN C7025
 3. DIMENSION "D" DOES NOT INCLUDE MOLD FLASH, TIE BAR BURRS AND GATE BURRS. MOLD FLASH, TIE BAR BURRS AND GATE BURRS SHALL NOT EXCEED 0.006"[0.15mm]" PER END. DIMENSION "E1" DOES NOT INCLUDE INTERLEAD FLASH. INTERLEAD FLASH SHALL NOT EXCEED 0.010"[0.25mm]" PER SIDE.
 4. DIMENSION "b" DOES NOT INCLUDE DAMBAR PROTRUSION. ALLOWABLE DAMBAR PROTRUSION SHALL BE 0.003"[0.08mm]" TOTAL IN EXCESS OF THE "b" DIMENSION AT MAXIMUM MATERIAL CONDITION. DAMBAR CANNOT BE LOCATED ON THE LOWER RADIUS OR THE FOOT. MINIMUM SPACE BETWEEN PROTRUSION AND AN ADJACENT LEAD TO BE 0.0028"[0.07mm]".
 5. TOLERANCE : ±0.010"[0.25mm]" UNLESS OTHERWISE SPECIFIED.
 6. OTHERWISE DIMENSION FOLLOW ACCEPTABLE SPEC.

SYMBOLS	DIMENSIONS IN MILLIMETERS			DIMENSIONS IN INCHES		
	MIN	NOM	MAX	MIN	NOM	MAX
A	0.81	1.02	1.22	0.032	0.040	0.048
▲ A1	0.05	—	0.15	0.002	—	0.006
A2	0.78	0.86	0.97	0.030	0.034	0.038
b	0.15	0.20	0.26	0.0059	0.0078	0.0098
C	0.13	0.15	0.23	0.005	0.006	0.009
D	2.90	3.00	3.10	0.114	0.118	0.122
E	4.80	4.90	5.00	0.189	0.193	0.197
E1	2.90	3.00	3.10	0.114	0.118	0.122
e	—	0.50	—	—	0.0196	—
L	0.40	0.53	0.66	0.016	0.021	0.026
▲ y	—	—	0.076	—	—	0.003
Ø	0"	3"	6"	0"	3"	6"

10-Pin MSOP

CUSTOMER :		ZYWYN CORPORATION	
APPROVED BY	DATE	TITLE:	
DRAW BY: <i>Viet Chen</i>	6/21/00	10L MSOP PACKAGE OUTLINE DRAWING	
CHECK BY: <i>Bill Wang</i>	6/20/00	DWG. NO.	PO-MSOP-003
APPROVAL: <i>David Lee</i>	6/20/00	REV.	1
APPROVAL: <i>Frank Ho</i>	6/20/00	UNIT :	mm
		SCALE :	12/1
		SHEET :	1 OF 1

Evaluation Board Information

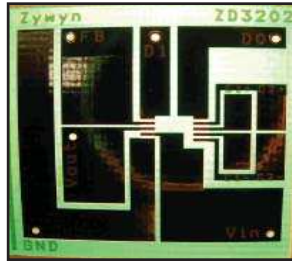
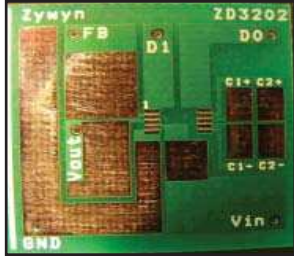

ZD3213EVB Evaluation Board Component Side Layout

ZD3213EVB Evaluation Board Solder Side Layout

Part Marking Information

TOPSIDE MARK INSTRUCTIONS:

← Line 1
← Line 2

Pin 1 Indicator (mold dimple)

Line 1: Zywyn Part Number "ZD32"
Line 2: Zywyn Part Number "13LU"

Note: Pin # 1 "Δ" Indicator Required if no Mold Dimple

BOTTOMSIDE MARK INSTRUCTIONS:

← Line 1
← Line 2

Line 1: Lot Number: XXXX.XX (Mark only the 4 characters underlined)
Line 2: Date Code: (Last 2 digits of Prod. Year & Prod. Work Week)

10-pin MSOP

Zywyn Corporation

Headquarters and Sales Office

1270 Oakmead Parkway, Suite 201 • Sunnyvale, CA 94085 • Tel: (408) 733-3225 • Fax: (408) 733-3206

Email: sales@zywyn.com • www.zywyn.com

Zywyn Corporation reserves the right to make changes to any products described herein. Zywyn does not assume any liability arising out of the application or use of any product or circuit described herein; neither does it convey any license under its patent rights nor the rights of others.

© 2010 Zywyn Corporation

