



High-Voltage Inductorless Regulated 4-Channel LED Driver

Features

- Drives 4 Channels of Multiple LED Strings with Matched, Regulated Current Sources of 80mA ~ 150mA
- No External Capacitors or Inductors Required (except Input Decoupling Capacitor)
- Low Drop-Out Current Sources Provide Excellent Current Regulation Over Wide Supply Operation
- Up To 150mA per Channel
- Input Supply Range +4.5V to +16V
- Dimming can be achieved with PWM Control of EN Pin or DC Voltage Level Control of the ISET Pin current
- Excellent Current Matching of each LED channel, 1.5% typ, within Each LED String
- LED Current Set with Single External Resistor, RSET
- Thermal Shutdown Protection
- Available in 2mm X 3mm 8-pin DFN Green Package

Applications

- Cellular Phones and Smartphones
- LCD Panel Display Backlighting
- LCD Module Backlighting
- PDAs and Portable Media Players
- Digital Camera and Camcorders
- Avionics and Navigation Displays
- Decorative Lighting
- Industrial Lighting
- Traffic Lighting
- Torch and Flash Lighting

Pin Configuration

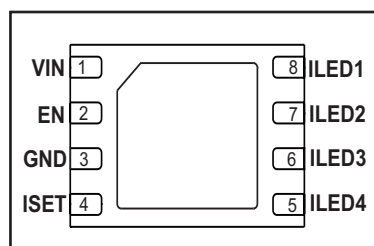

8-Pin 2x3 DFN
with Exposed Bottom Pad

General Description



The ZD3315 contains 4 channels of linear regulated, low drop out current sources, specifically designed to drive up to 4 strings of LED's with 150mA sourcing current per channel. Each LED string operates individually by terminating to an internal, regulated current sink, which provides matched and consistent LED current over a wide input supply range. The LED currents are set by an external resistor, RSET, connected to the ISET pin. The EN pin provides a chip enable function and can be used with a PWM pulse to achieve a dimming control function. Dimming can also be achieved by applying a DC voltage through the RSET or a resistor network at the ISET pin.

The ZD3315 is available in a 2mm x 3mm 8-pin DFN green

Ordering Information

Part Number	Temperature Range	Package Type
ZD3315LED	-40°C to +85°C	8-Pin 2x3 DFN
ZD3315EVB	n/a	Evaluation Board

Please contact the factory for pricing and availability on Tape-on-Reel option.

Typical Application

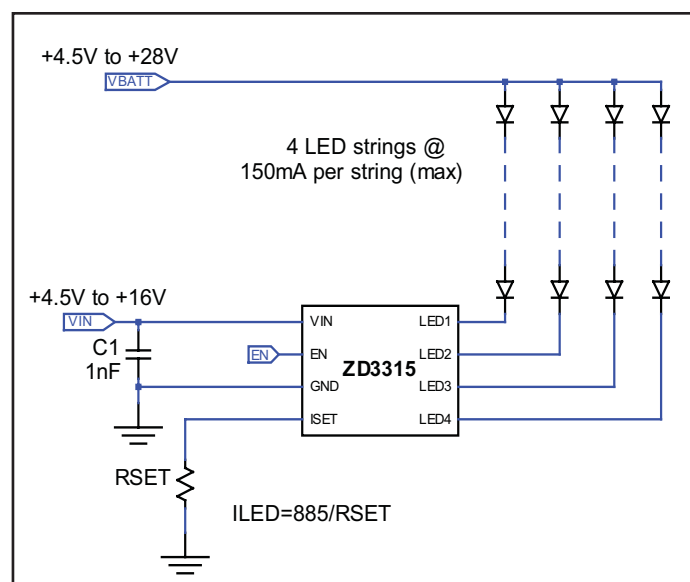

Figure 1. ZD3315 driving 4 channels of LED strings in series in dual power supply mode.

Specifications subject to change without notice

Absolute Maximum Ratings

These are stress ratings only and functional operation of the device at these ratings or any other above those indicated in the operation sections of the specifications is not implied. Exposure to absolute maximum rating conditions for extended periods of time may affect reliability.

Input Voltages, VIN, EN, LED_{1~4} +20V
ISET +6V

Extended Commercial

Operating Temperature -40°C to +85°C
Maximum Junction Temperature, T_J +150°C
Storage Temperature -65°C to +150°C
Lead Temperature (Soldering, 10sec.) 300°C

Power Dissipation Per Package

2x3 8-pin DFN 1.1W
Package Thermal Resistance
Θ_{JA}* 120°C/W

Storage Considerations

Storage in a low humidity environment is preferred. Large high density plastic packages are moisture sensitive and should be stored in Dry Vapor Barrier Bags. Prior to usage, the parts should remain bagged and stored below 40°C and 60%RH. If the parts are removed from the bag, they should be used within 168 hours or stored in an environment at or below 20%RH. If the above conditions cannot be followed, the parts should be baked for 12 hours at 125°C in order to remove moisture prior to soldering. Zywyn ships product in Dry Vapor Barrier Bags with a humidity indicator card and desiccant pack. The humidity indicator should be below 30%RH. The MSL of this product is 3.

The information furnished by Zywyn has been carefully reviewed for accuracy and reliability. Its application or use, however, is solely the responsibility of the user. No responsibility of the use of this information become part of the terms and conditions of any subsequent sales agreement with Zywyn. Specifications are subject to change without the responsibility for any infringement of patents or other rights of third parties which may result from its use. No license or proprietary rights are granted by implication or otherwise under any patent or patent rights of Zywyn Corporation.

Electrical Characteristics

T_A = +25°C, VIN = EN = +5V, VLED_{1~4}=1V, RSET = 10kΩ; unless otherwise noted.

Parameter	Condition	Min	Typ	Max	Units
Operating Voltage (VIN)		4.5		16	V
ILED Current Scale Factor, K	ILED=[(Scale Factor)/(RSET)] for ILED = 88~150mA	796	885	973	
MAX LED Current (per channel)	RSET=6.2KΩ, VLED=1.5V, Average of ILED _{1~4}		150		mA
Supply Current (ICC)	RSET = 10kΩ		3	4.5	mA
ILED in OFF Mode	EN=0V, VLED < 5V		1		μA
LED Current Line Voltage Regulation	ILED change per VIN volt change		0.2		%/V
LED Current Load Voltage Regulation	ILED=100mA, VLED=0.4V~5V		2		%/V
LED Current Matching	RSET = 10kΩ		± 1.5	± 3	%
ISET Pin Voltage			1.5		V
EN Voltage High, V _{IH}		2		VIN	V
EN Voltage Low, V _{IL}		0		0.6	V
EN Pin Bias Current			10		μA
Thermal Shutdown Temperature			150		°C

* measured in natural convection at T_A = 25°C on a low effective thermal conductivity test board of JEDEC 51-3 thermal measurement standard.

Block Diagram

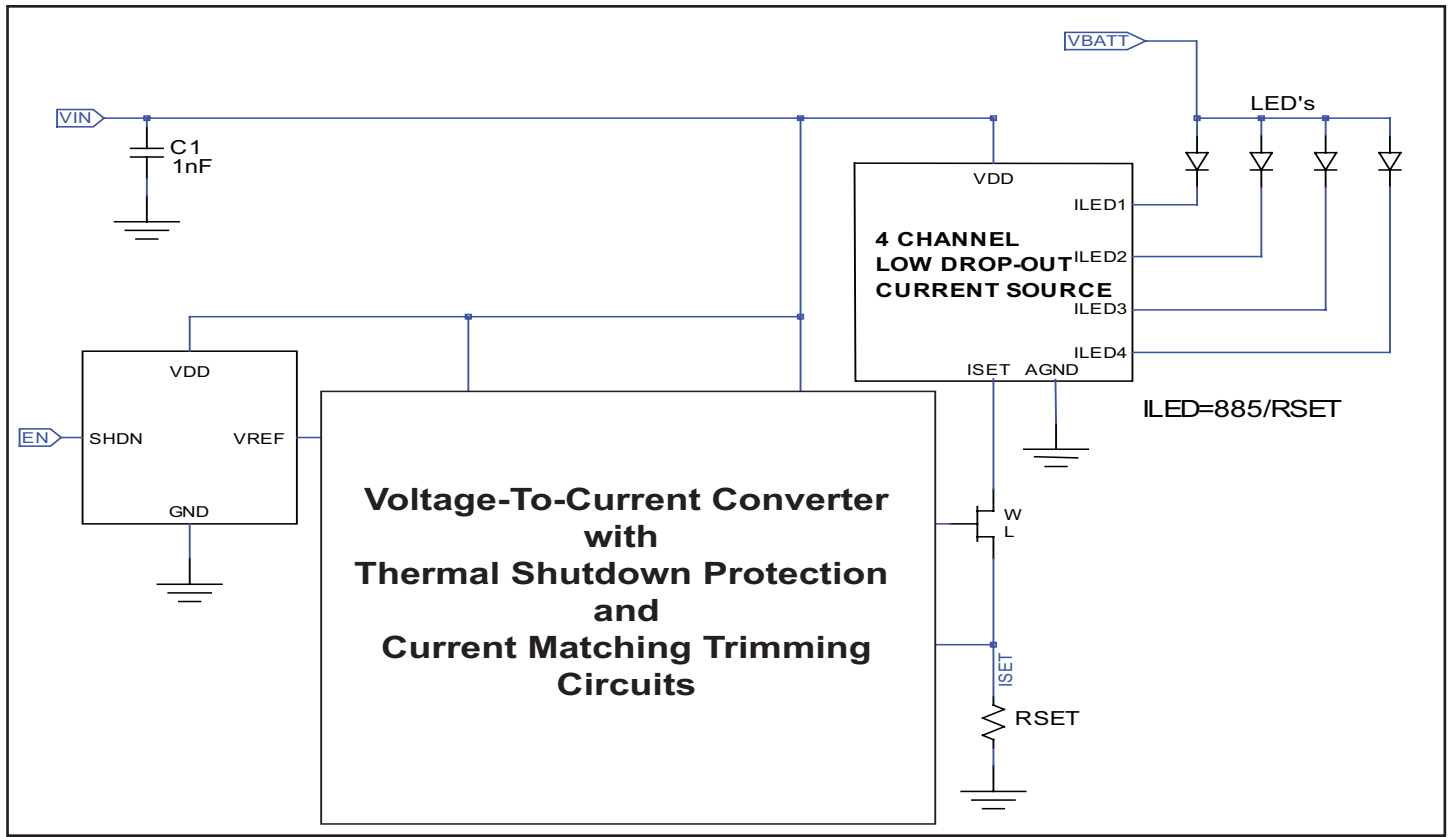

Fig.2. ZD3315 Typical Block Diagram

Pin Description

Pin Number	Pin Name	Pin Function
1	VIN	Input Supply Voltage Pin. Decouple with 1nF capacitor.
2	EN	Chip ENABLE Pin. Active high "H".
3	GND	Supply Return (Ground). Exposed pad needs to be connected to circuit ground.
4	ISET	Sets ILED Current with External Resistor. $I_{LED} = (885)/(R_{SET})$
5	ILED4	LED Current Source #4.
6	ILED3	LED Current Source #3.
7	ILED2	LED Current Source #2.
8	ILED1	LED Current Source #1.

Circuit Description

The ZD3315 contains 4 channels of linear regulated, low drop out current sources, specifically designed to drive up to 4 strings of LED's with 150mA sourcing current per channel. Each LED string operates individually by terminating to an internal, regulated current sink, which provides matched and consistent LED current over a wide input supply range. The LED currents are set by an external resistor, RSET, connected to the ISET pin. The EN pin provides a chip enable function and can be used with a PWM pulse to achieve a dimming control function or a DC voltage can be inserted into the ISET pin to control the LED currents..

Power Dissipation and Thermal Shutdown

For thermal performance, the GND pin and exposed pad of the ZD3315 should be connected to a strong ground plane for heat sinking and noise protection.

The power dissipation of the ZD3315 is determined by the sum of the ILED currents on each channel multiplied by VLED. ($P_D = V_{LED} \times I_{LED}$) This result should be kept under 1.1W for safe operation in $T_A = 25^\circ\text{C}$. The maximum power dissipation on the package can be calculated using the formula:

$$P_{D(MAX)} = (T_{J(MAX)} - T_A) / \theta_{JA} = (150^\circ\text{C} - T_A) / (120^\circ\text{C/W})$$

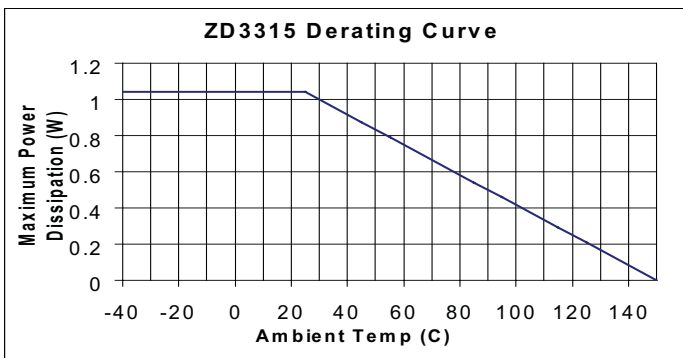

Figure 3. Derating curve for ZD3315.

The ZD3315 contains an internal temperature sensor that shuts down the output regulator when the die temperature exceeds $+150^\circ\text{C}$. The constant current output is enabled again when the die temperature drops below $+140^\circ\text{C}$. This characteristic is evident when the LEDs are cycling between ON and OFF as the device repeatedly overheats and cools off.

Current Programming of the ZD3315

The ZD3315 is configurable to regulate current on 4 strings of LEDs. A resistor R_{SET} is connected from the I_{SET} pin to GROUND and the I_{LED} current is determined by the equation

$$I_{LED} = 885 / R_{SET}$$

where RSET is in the range of $[10\text{K}\Omega \geq R_{SET} \geq 5.9\text{K}\Omega]$

Enable Pin

The EN pin of the ZD3315 can be tied to the VIN pin (+16V max.) or to a logic high (+5V) to turn on the device, or to GND to put the device into shutdown mode.

PWM Dimming

The output string of series LEDs can be dimmed by applying an input pulse-width modulated signal (100Hz to 5kHz) to the enable EN pin. This allows for a wide range of dimming gradient. The dimming is proportional to the PWM duty cycle, which can range from 10% to 90%. The device is in shutdown mode when PWM is at LOGIC LOW "0" state, and is fully-on when PWM is at a LOGIC HIGH "1" state.

Analog Voltage Dimming

To allow for LED current amplitude adjustment as well as linear dimming, ISET can be connected to an analog voltage through the resistor, RSET, where RSET is in the range of $10\text{K}\Omega \geq R_{SET} \geq 5.9\text{K}\Omega$. The ISET pin is typically regulated at 1.5V.

As shown in Figure 4, when the DC voltage is set at 0V for example, the I_{LED} current is positioned at its default value which is calculated from the equation,

$$[I_{LED}] = [885 / (R_{SET})]$$

Increasing the DC voltage from 0V to 1.5V will dim the LEDs in linear proportion with decreased in the I_{LED} current. Setting the DC voltage at midpoint upon device power-up can control the dimming up and down function.

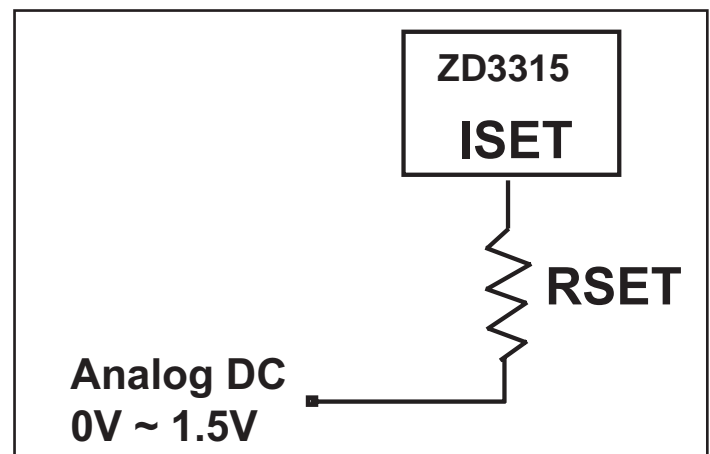

Figure 4. Analog dimming using analog DC voltage.

Input Operation Description

Single Power Supply Mode

The ZD3315 can be operated using a supply voltage of 4.5V ~ 16V connected to the VIN (Pin 1). This voltage range of 4.5V ~ 16V can be connected to the ANODE of the LED string(s), depending on application and the total forward voltage of the LED string(s).

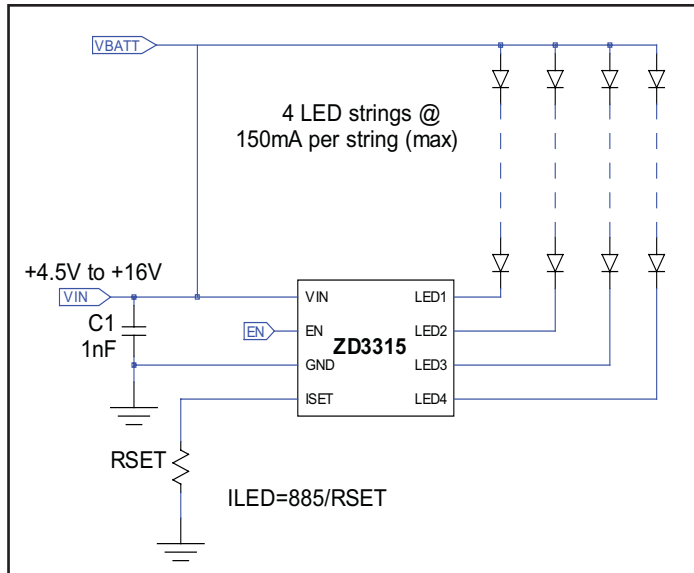

Figure 5. ZD3315 driving 4 channels of LED strings in series in single power supply mode with VIN = VBATT = 4.5V ~ 16V.

Dual Power Supply Configuration

The VIN pin of the ZD3315 can be connected to a voltage source of 4.5V to 16V. The anode of the LED string(s), VBATT, can be connected separately to another voltage source in the range of 4.5V to 28V, depending on the application and the number of LEDs in series per string being used. Caution must be taken to ensure the LED pins are within the maximum VLED specification limits, for thermal shutdown consideration. See page 4 for reference.

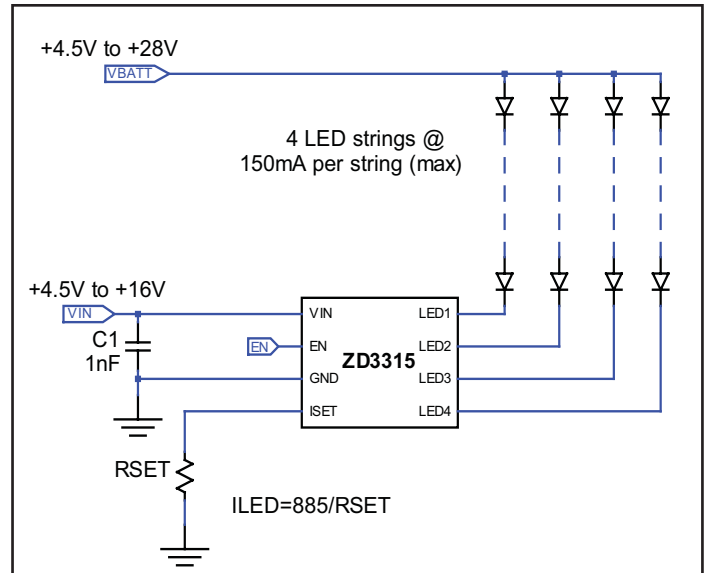
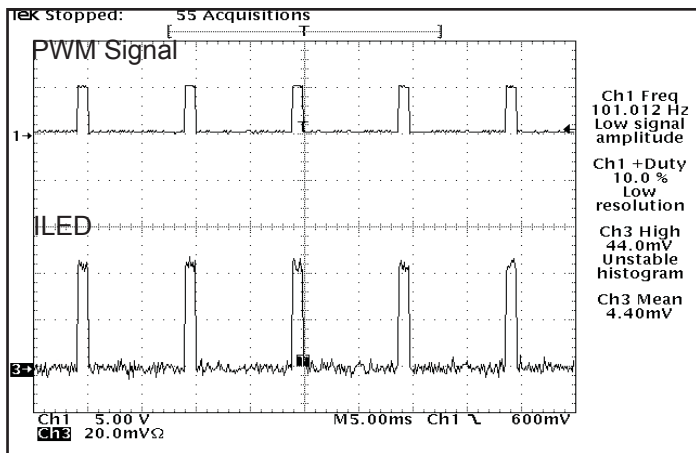

Figure 6. Dual power supply configuration.

Typical Performance Characteristics

$V_{Forward-LED} = 3.2V$, $V_{IN} = 5V$, $T_A = 25^\circ C$ Unless Otherwise stated.



PWM Function; 100Hz 10% Duty Cycle

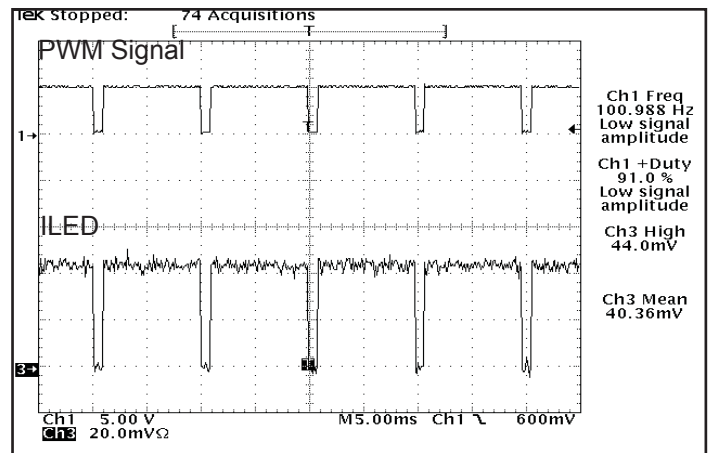

PWM Function; 100Hz 90% Duty Cycle

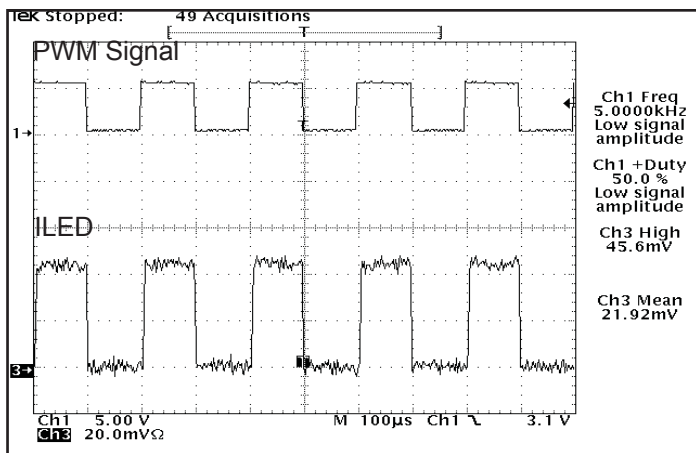

PWM Function; 5kHz 50% Duty Cycle

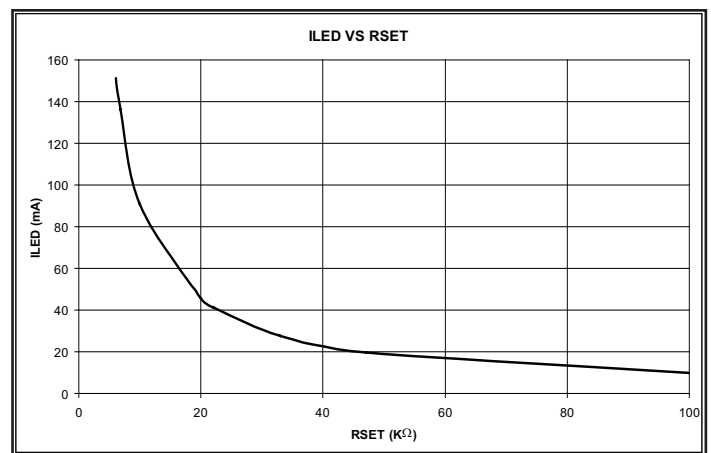

LED current (ILED) vs RSET (per channel)

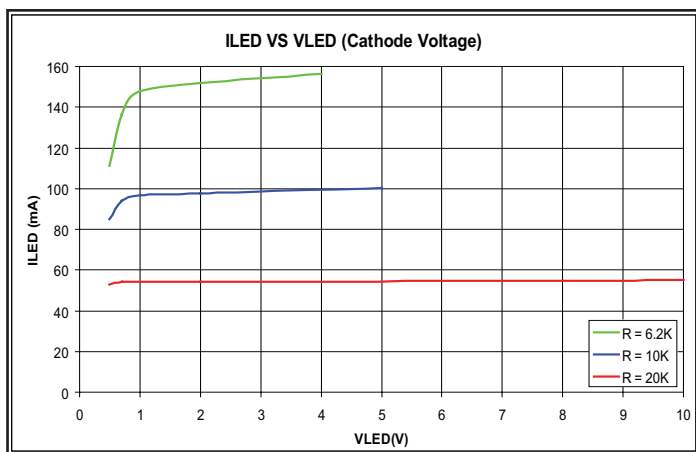

Load Voltage Regulation; LED current (ILED) vs VLED per channel with respect to RSET setting.

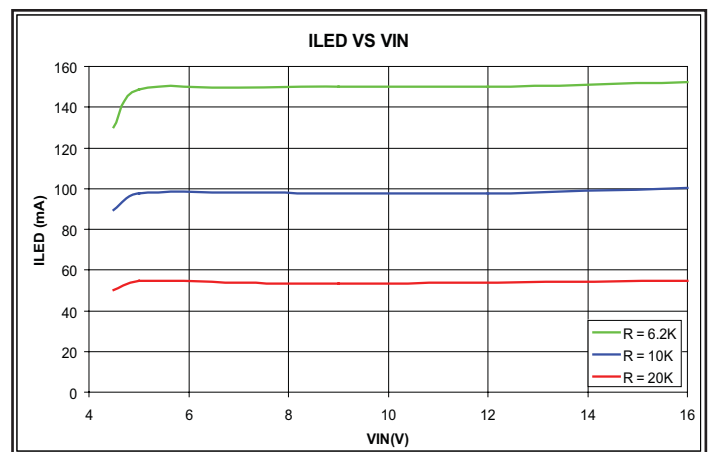

Line Voltage Regulation; LED current (ILED) vs VIN per channel with respect to RSET setting.

Green Package SMD IR Reflow Profile Information

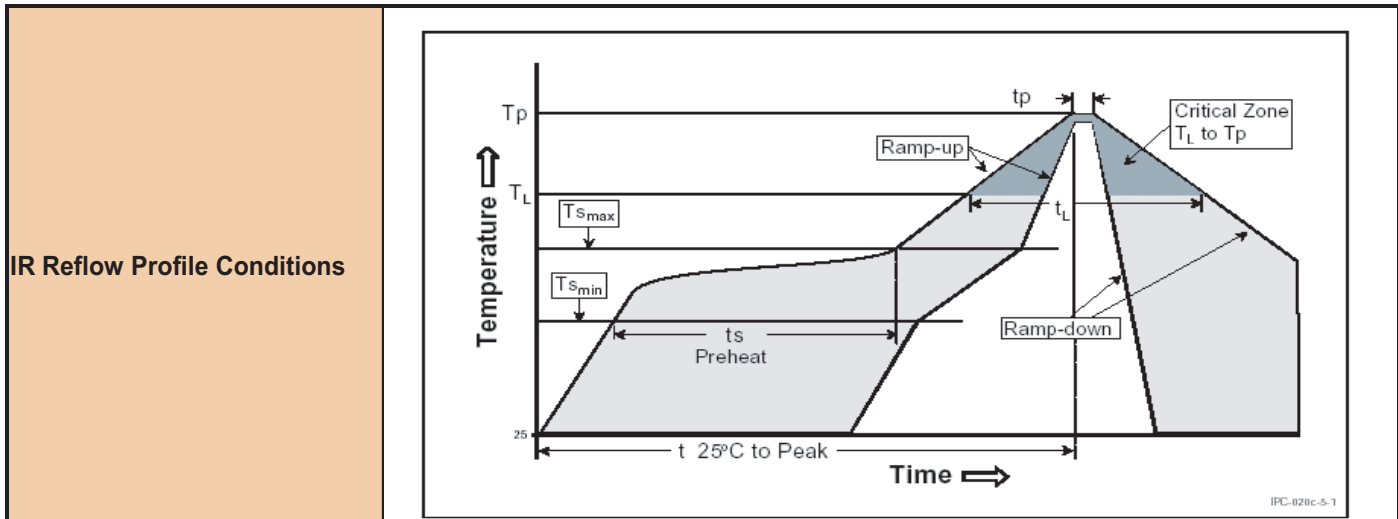

Profile Feature	JESD Sn-Pb Eutectic Assembly	JESD Pb-free Assembly
Average Ramp-Up Rate (T_{Smax} to T_P)	3°C/seconds max.	3°C/seconds max.
Pre-heat		
- Temperature Min (T_{Smin})	100°C	150°C
- Temperature Max (T_{Smax})	150°C	200°C
- Time (T_{Smin} to t_{Smax})	60~120 seconds	60~180 seconds
Time maintained above:		
- Temperature (T_L)	183°C	217°C
- Time (t_L)	60~150 seconds	60~150 seconds
Peak/Classification Temperature (T_P)	235°C+5/-0°C	255°C+5/-0°C
Time within 5°C of actual Peak Temperature (t_p)	10~30 seconds	20~40 seconds
Ramp-Down Rate	6°C/second max.	6°C/second max.
Time 25°C to Peak Temperature	6 minutes max.	8 minutes max.

Zywyn Green Packages are Pb-free and RoHS compliance.

Package Information

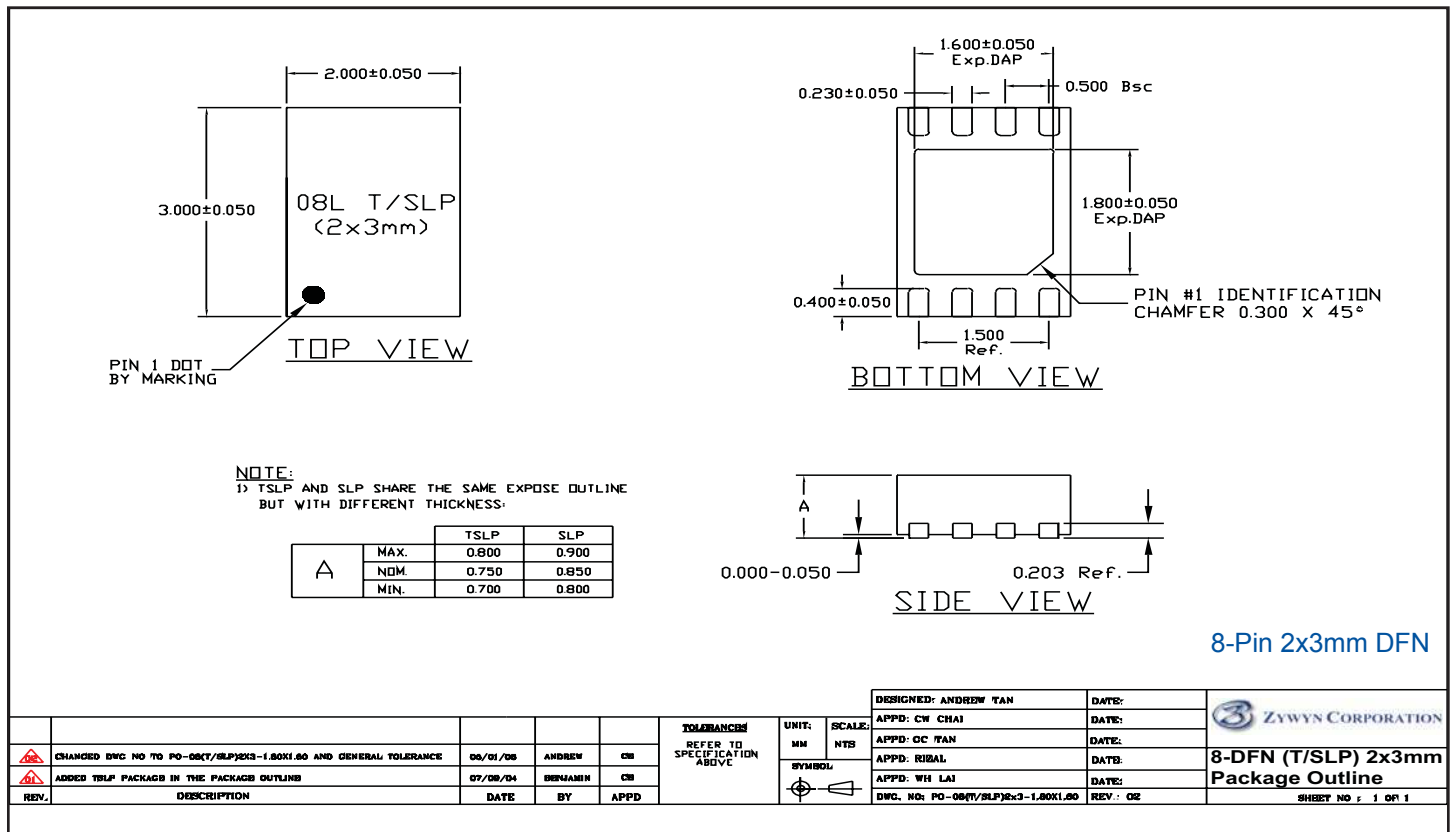

Evaluation Board Information

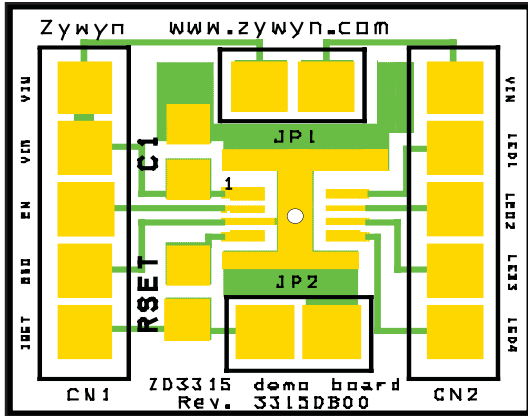

ZD3315EVB Evaluation Board Top Side With Components Layout

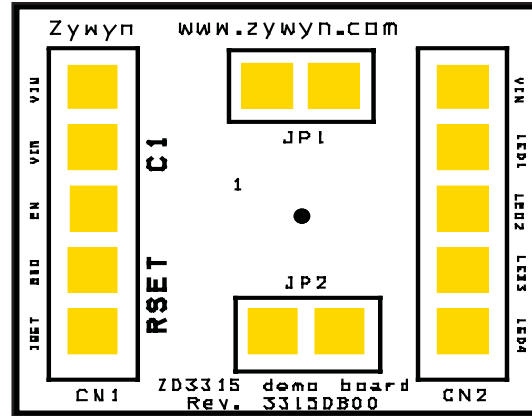

ZD3315EVB Evaluation Board Bottom Side Layout

Part Marking Information

TOPSIDE MARK INSTRUCTIONS:

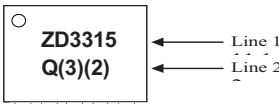

Line 1: Zywyn Part Number "ZD3315"
 Line 2: Zywyn's Part Identification Code "Q(3)(2)"
 where (3) is a 2-character Lot # code
 (2) is a 1-character date-code
 Refer to Zywyn's WLED Part Marking Table for details.

BOTTOMSIDE MARK INSTRUCTIONS:



No Backside marking.

2x3 8-DFN

Zywyn Corporation

Headquarters and Sales Office

1270 Oakmead Parkway, Suite 201 • Sunnyvale, CA 94085 • Tel: (408) 733-3225 • Fax: (408) 733-3206

Email: sales@zywyn.com • www.zywyn.com

Zywyn Corporation reserves the right to make changes to any products described herein. Zywyn does not assume any liability arising out of the application or use of any product or circuit described herein; neither does it convey any license under its patent rights nor the rights of others.

© 2011 Zywyn Corporation