

PICAXE MICRO-ROBOT

Contents:

- Section 1 - General Information
- Section 2 - AXE120 Contents
- Section 3 - Optional Upgrades
- Section 4 - Initial Assembly
- Section 5 - Power Supply
- Section 6 - Serial Cable and Software
- Section 7 - Inputs
- Section 8 - Additional Outputs
- Section 9 - Motor Outputs / Speed Control
- Section 10 - Sample Speed Control Program
- Section 11 - Circuit Diagram
- Section 12 - Using the AXE122 Bumper Switch kit
- Section 13 - Using the AXE121 Line Follower kit
- Section 14 - Using the SRF004/005 Ultrasonic kit
- Section 15 - Using the AXE040 Infra-Red kit



1) General Information:

The PICAXE micro-robot system provides an exciting, economical introduction to the world of robotics. The system can be fully customised by the end user, with the capacity to add 5 input sensors and 4 output devices (in addition to the default motor/gearbox outputs).

The micro-robot base unit consists of a plastic enclosure (120 x 80mm) which houses the 4 AA batteries (not supplied), the two central 0.46W motors and the 42:1 ratio gearboxes. This base unit is then fitted with the pre-soldered control board, which contains the PICAXE-18 microcontroller (can be upgraded to PICAXE-18A or 18X if desired). The PICAXE-18 microcontroller can be programmed 'on-board' by simply connecting the AXE026 download cable into the socket provided. The user can then develop their own simple BASIC or flowchart control program using the free PICAXE 'Programming Editor' software.

A unique feature of the control board is its custom 'PWM motor speed controller' chip. This controls the speed of the motors, which gives the user fully programmable speed control of the micro-robot. This allows the micro-robot to move in any direction at a range of user-selected speeds.

Various 'add-on' modules for the micro-robot are also separately available (modules can be used simultaneously if desired). These include line follower, infra-red control and ultrasonic range finding options. Naturally the user can also build their own sensors to produce their own custom robot!

2) AXE120 Contents:

- PICAXE micro-robot control PCB (printed circuit board)
- Micro-robot chassis/gearbox unit
- 4 M2.5 6mm screws

Also supplied in starter pack AXE120S:

- AXE026 PICAXE download cable
- BAS805 PICAXE 'Programming Editor' software (or download free from www.picaxe.co.uk)
- AXE122 Bumper switch pack

Also required (not supplied):

- 4 x AA cells (alkaline recommended - part BAT002)

3) Optional Upgrades:

- AXE122 Bumper switch pack (see page 7)
- AXE121 Line Follower module (see page 8)
- SRF004 Ultrasonic Range Finder module (see page 10)
- AXE040 Infra-red Remote Control kit (see page 11)
- SPE002 Piezo Sounder (see page 3)

4) Initial Assembly

- 1) Remove all of the light green (or blue) colour protective coating over the spare solder pads on the bottom of the control PCB. Use an offcut of wire to clear any holes that are blocked.
- 2) Place the control PCB on top of the buggy and secure in place with the 4 screws.
- 3) Connect the power and motor wires to the headers provided. Take care that no wires are caught on the wheels.



5) Power Supply

The micro-robot is designed to run from 6V via 4xAA cells ($4 \times 1.5V = 6V$ with alkaline cells).

Insert the cells into the plastic base, ensuring correct polarity. Make sure the brass contacts make good contact - after several insertions/removals it may be necessary to bend the brass contacts slightly. Take care not to dislodge the brass strip that runs down the side of the chassis to connect the two sets of batteries together.

If using rechargeable cells, only 4.8V will be supplied to the micro-robot, which will reduce the speed ($4 \times 1.2V = 4.8V$). If desired, this problem can be partially overcome by soldering a wire link between the two pads at the top of the 18 pin PICAXE microcontroller. This bypasses the safety diode D1, which produces a 0.7V drop to the micro-robot. This therefore increases the voltage to the micro-robot from 4.1V to 4.8V, but also removes the safety feature, and so accidental reversed connection of the batteries could damage all the chips on the control board.

6) Serial Cable and Software

For programming the micro-robot, the PICAXE serial download cable AXE026 connects into the socket provided on the control PCB.

If your computer does not have a 9 way serial port for the AXE026 download cable, use the AXE027 USB cable instead of AXE026.

The Programming Editor software is used to program the PICAXE microcontroller on the control PCB to control the micro-robot. This software is free and can be downloaded from www.picaxe.co.uk

7) Inputs

The micro-robot has 5 inputs. The various optional upgrade modules use certain inputs as shown in the table below. If not already used by an upgrade, these inputs are available for general use. Inputs 1,2,6,7 all have a 10k pull-down resistor on the control PCB. Input 0 has a 4k7 pull-up resistor on the control PCB.

Therefore the input switch can be simply connected between the two pads provided in each of the input positions. No other electronic components are required.

Module	Out3	In0	In1	In2	In6	In7
line follower			X	X	X	
infrared		X				
ultrasonic	X					X

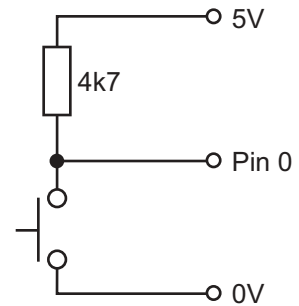
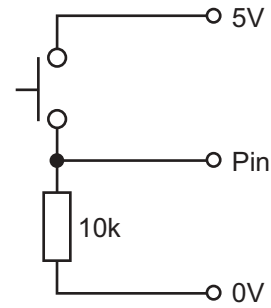

8) Additional Outputs

The micro-robot motors are controlled by outputs 4 to 7 (see section 9). Output3 is used by the optional SRF004 ultrasonic range finder. Outputs 0, 1 and 2 are available for general use, via the sets of pads at the rear of the micro-robot.

Each output set has three pads (0V, V+ and output pin connection). The output pin connection connects via the resistor (R-0, R-2 or R-2) to the microcontroller. Therefore this resistor **must** be fitted (with an appropriate value for the desired output device) for the output to operate correctly.

Adding an LED

Solder a 330R (orange orange brown gold) resistor in the appropriate resistor position (R-0 to R-2 for output 0 to 2). Solder the LED positive (long) leg in the top hole and the short leg in bottom hole. Switch the LED on and off by using 'high' and 'low' commands.

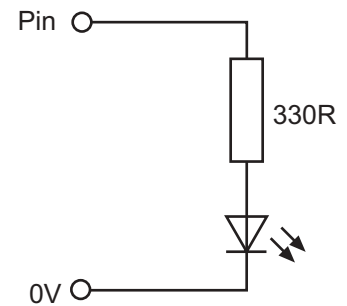

Adding a piezo sounder

Solder a wire link (e.g. discarded resistor leg) in the appropriate resistor position (R-0 to R-2 for output 0 to 2). Solder the piezo positive (red) wire in the top hole and the black wire in bottom hole. Use the 'sound' command to generate beep sounds.

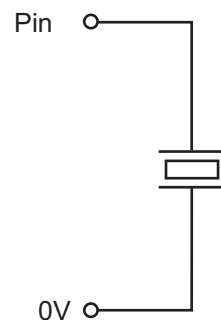

Adding a radio control servo.

Solder a 330R (orange orange brown gold) resistor in the appropriate resistor position (R-0 to R-2 for output 0 to 2). Solder a three pin header in the output connector. Connect the servo to the header with the black wire in position marked '-' (the bottom hole). Note you will require to upgrade the original PICAXE-18 microcontroller to a PICAXE-18A or PICAXE-18X to use the 'servo' command.

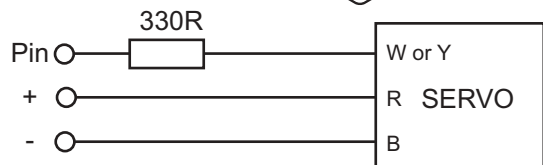
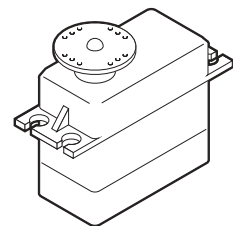

9) Motor Outputs / Speed Control:

The micro-robot motor/gearboxes can be controlled to make the robot turn, and the speed of the motor can also be adjusted. The motors are controlled by PICAXE output 4 to 7.

The table shows how to control the direction of the robot.
 To move forwards use the command **let pins = %10100000**
 To move backwards use the command **let pins = %01010000**

The speed of the robot is controlled by a technique called PWM (pulse width modulation), where the output is rapidly switched on and off at high frequency. By varying the 'on' time to 'off' time ratio, the speed of the micro-robot motors can be varied. The PWM pulsing function is provided continuously by the 8 pin speed controller chip fitted to the control board.

7	6	5	4	Direction Control
0	0	0	0	Stop
1	0	1	0	Forward
1	0	0	1	Turn Left
0	1	0	1	Reverse
0	1	1	0	Turn Right
				Speed Control
0	Pulse	1	1	Set Speed Left
1	1	0	Pulse	Set Speed Right

The speed of each motor can be adjusted individually, although it is more common to keep both motors running at roughly the same speed. Speed is adjusted by first setting two pins high, and then using a 'pulsout' command, followed by a number between 50 (slow) and 255 (fast). Note that numbers less than 50 will probably cause the gearbox to stall. See sample program in section 10 for an example.

Note that it is normal for DC motors to run at slightly different speeds due to manufacturing tolerances of each motor - this is NOT a fault, and may cause the robot to veer slightly to one side when moving in a straight line. It may be possible to set each motor at slightly different speeds to compensate this veer e.g. left motor at speed 50 and right motor at speed 51. Experiment to find the best values for your motors.

On power up the motors default to speed 128. Note that as the PWM speed controller chip takes a few microseconds to initialise after power-up, each micro-robot PICAXE program should always start with a 'pause 100' command to allow the chip to initialise. before speed data is transmitted.

10) Sample program

This sample program starts the micro-robot forwards at full speed . If input2 or input 6 is activated, the micro-robot then reverses for 3 seconds at slow speed, turns and then starts going forwards again.

```

symbol speedR = b1
symbol speedL = b2

        pause 100                ` motor controller start-up pause
main:
    let speedR = 255              ` maximum speed
    let speedL = 255              ` maximum speed
    gosub set_speed               ` set the speed
    let pins = %10100000          ` buggy forward
lp1:
    if input6 is on or input2 is on then stopit
    goto lp1                      ` loop around

stopit:
    let pins = %00000000          ` stop
    let speedL = 60                ` set slow speed
    let speedR = 60                ` set slow speed
    gosub set_speed               ` set the speed
    let pins = %01010000          ` reverse
    pause 3000                    ` wait 3 seconds
    let pins = %10010000          ` turn
    pause 2000                    ` wait 2 seconds
    goto main                     ` loop

set_speed:
    let pins = %00110000          ` set left speed
    pulsout 6,speedL              ` send a pulse of length in 'speedL'
    pause 10                      ` short delay
    let pins = %11000000          ` set right speed
    pulsout 4,speedR              ` send a pulse of length in 'speedR'
    pause 10                      ` short delay
    return

```

12) Using the AXE122 Bumper Switch Kit

The optional bumper switch kit (part AXE111) provides two long arm ‘bumper’ switches that can be connected to any of the inputs (0,1,2,6,7) marked on the PCB.

However make sure these inputs are not already in use by another module before soldering. The module input/output usage is as follows:

Module	Out3	In0	In1	In2	In6	In7
line follower			X	X	X	
infrared		X				
ultrasonic	X					X



Kit Contents/ Assembly:

- 2 micro switch
- 2 plastic spacer
- 2 M3 20mm bolts
- 2 double wire connectors (may be supplied as triple wire connectors)

- 1) If the double wire connectors are supplied with three wires, use a pair of scissors to cut off the spare wire, as only two wires are required.
- 2) Solder one wire of each pair to the ‘C’ terminal on the switch, and the other wire to the ‘NO’ connector on the switch.
- 3) Solder the other end of the wire pair to the selected input holes on the micro-robot. The wires can be soldered either way around.
- 4) Carefully bend the last 10mm of the switch as shown in the photograph. This helps stop the switch ‘jamming’ on obstacles.
- 5) Use the plastic spacers and M3 screws to mount the switches in position. Note that the screw is tightened directly into the plastic hole on the switch body.

Sample program:

This sample program stops the micro-robot if input2 or input 6 is activated.

```

main:
    pause 100                \ motor controller start-up pause
    let pins = %10100000    \ buggy forward
lp1:
    if input6 is on or input2 is on then stopit
    goto lp1                \ loop around

stopit:
    let pins = %00000000    \ stop
    goto stopit
    
```

13) Using the AXE121 Line Follower Kit

The optional infra-red line-followr kit (part AXE121) allows the AXE120 micro-robot to follow a line drawn on the floor. Three infra-red sensors are used to detect the edges of the line, so that the micro-robot can follow the line.

IMPORTANT NOTES:

Do not remove ST-7L INFRARED SENSORS from the separate packet until required, as the infrared sensors and EL-7L infrared LEDs look identical - do not mix up! IR1-3, Q1-3 and C1-3 are mounted on the BOTTOM of the PCB

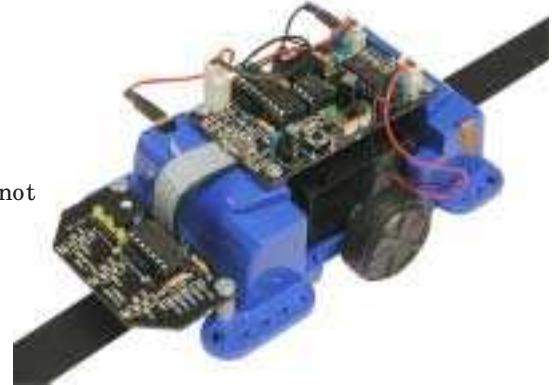

Kit Contents/ Assembly:

- Hardware
- PCB
- 5 pin CABLE
- 2x M3 nuts
- 2x M3 20mm bolts
- 2x nylon spacers

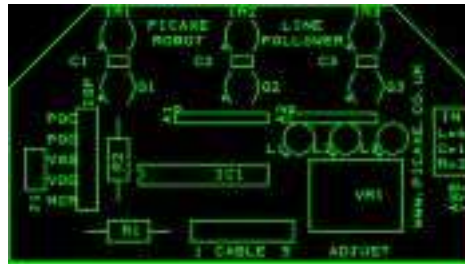

Components mounted on TOP of PCB (ie solder on bottom of PCB)

- IC1 14 pin IC socket and pre-programmed PIC16F676
- R1 4k7 resistor (yellow violet red gold)
- R2 12R resistor (brown red black gold)
- A1 4k7 resistor array (marked 472G)
- A2 1k resistor array (marked 102G)
- VR1 100k preset
- L1-3 3mm yellow LED

- 1) Solder the two resistors R1 (4k7) and R2 (12R) in position.
- 2) Solder the IC1 14 pin socket and VR1 preset in position.
- 3) Solder the three yellow LEDs L1-3 in position, making sure the long leg is in the hole marked +.
- 4) Solder resistor arrays A1 and A2 in position. Make sure the ink 'dot' at the end of the array aligns with the dot marked on the PCB (to the left).
- 5) Solder the 5 core cable in the position marked CABLE
- 6) Place the microcontroller into the 14 pin socket, ensuring pin1 (dent) faces the left hand side.



Note that the positions marked ISP and JP1 are not normally used.

Components mounted on BOTTOM of PCB (ie solder on top of PCB)

- C1-3 100nF capacitors
- IR1-3 3mm infrared (clear) LED EL-7L
- Q1-3 3mm infrared phototransistor ST-7L

- 1) Solder the three capacitors C1-3 in position. These act as a 'wall' between the infrared LED and phototransistor, to ensure only reflected light is detected.
- 2) Solder the three clear infrared LEDs IR1-3 in position, making sure the long leg is in the hole marked +. Make sure the LED sits 'flat' and straight on the PCB.
- 3) Solder the three ST-7L phototransistors Q1-3 in position, making sure the long leg is in the hole marked +. Make sure the phototransistor sits 'flat' on the PCB.



Connecting to micro-robot and testing.

- 1) Remove control PCB from top of the micro-robot.
- 2) Solder the 5 pin cable to the main micro-robot control PCB. Use the **INNER** set of 5 holes marked 'CABLE', not the outer SRF005 connector. The cable should come from below the control PCB, so that you are soldering on the top of the control PCB.
- 3) Use the M3 nuts, bolts and spacers to mount the line follower module at the front of the micro-robot as shown.
- 4) Replace control PCB on top of micro-robot.
- 5) Switch the micro-robot on. Hold the micro-robot above a black line (e.g. black insulation tape) on white background. Each yellow LED should come on as the corresponding sensor is moved over a black line. Use the preset resistor to adjust the sensitivity.

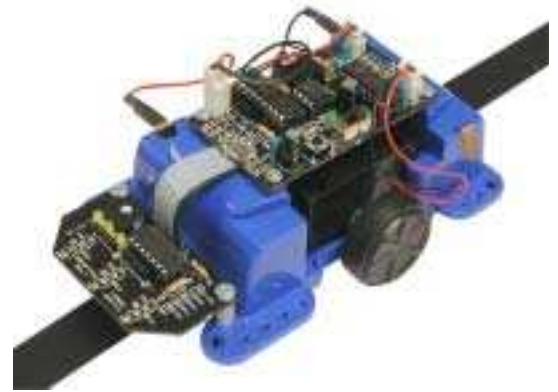

Note - ensure you connect the cable to the inner CABLE holes on the microbot PCB (not the outer SRF005 connection holes!)

Advanced Use Only (optional adjustments).

- 1) Solder a jumper link or switch in position JP1 to invert colours (ie to follow a white line on a black background).
- 2) The PIC16F676 can be re-programmed (if desired, by users familiar with assembler code) via the header marked ISP.

Operation.

The pre-programmed PIC16F676 micro-controller cycles each infra-red LED/sensor pair in turn. Each LED is quickly switched on and off by itself to create a burst of light. The amount of light reflected from the ground is then measured by the infra-red sensor (white and black backgrounds reflect different amounts of light). If the reflected light level indicates a black line, the corresponding output LED is lit.

Sample program.

This sample program shows how to follow a line. It is a simple program using no speed control - naturally you can be more creative, and, for instance, adjust the program so the micro-robot goes faster when over the black line, or adjust the program so that it 'hunts down' the nearest black line - be creative!

```

init: pause 100                \ motor controller start up pause
main:
    if input1 is on then go_f   \ forward
    if input2 is on then go_l   \ left
    if input6 is on then go_r   \ right
    goto go_s                   \ stop as no line nearby

go_f: let pins = %10100000     \ go forward
    goto main

go_l: let pins = %00100000     \ go left
    goto main

go_r: let pins = %10000000     \ go right
    goto main

go_s:
    let pins = %00000000       \ stop - not over line!
    goto main

```

14) Using the SRF004 / SRF005 Ultrasonic Range Finder

The optional ultrasonic range finder (part SRF004 or SRF005) allows the micro-robot to detect obstacles in front of it. The ultrasonic range sensor detects objects in its path and can be used to calculate the range to the object. It is sensitive enough to detect a 3cm diameter broom handle at a distance of over 2m. In use the PICAXE sends a trigger pulse to the ultrasonic unit (output 3), and then times how long the ultrasonic echo takes (input 7). This gives the distance to the nearest object.

See the SRF004 or SRF005 datasheet for further information on how the module operates.



Required:

SRF004 or SRF005 module (supplied with 5 pin header)
CON041 5 pin socket

Assembly:

- 1) Remove control PCB from top of the micro-robot.
- 2) Solder the 5 pin socket (part CON041) in the **outer** position marked SRF004.
- 3) **SRF004** - Solder the 5 pin header (supplied with SRF004) to the SRF004 module, taking care not to overheat the small pads whilst soldering.
SRF005 - Cut off the 4th 'mode' pin from the 5 pin header (see diagram), so that no connection is made to the mode pin on the module. Solder the remaining 4 pins to the SRF005 module, taking care not to overheat the small pads whilst soldering.
- 4) Replace control PCB on top of micro-robot.
- 5) Push the ultrasonic module into the CON041 socket.



Sample program:

This sample program stops the micro-robot if an object is detected within 10cm.

```

symbol trig = 3           \ Define output pin for Trigger pulse
symbol echo  = 7         \ Define input pin for Echo pulse
symbol range = w1        \ 16 bit word variable for range

main:
    pause 100            \ motor controller start-up pause
    let pins = %10100000 \ buggy forward

lp1:
    pulsout trig,2       \ produce 20uS trigger pulse
    pulsin echo,1,range  \ measures the range in 10uS steps
    pause 10             \ SRF004 mandatory recharge period

    \ now convert range to cm (divide by 5.8)
    \ and stop if there is an object closer than 10 cm
    let range = range * 10 / 58 \ multiply by 10 then divide by 58
    if range < 10 then stopit
    goto lp1             \ loop around if > 30

stopit:
    let pins = %00000000 \ stop
    goto stopit

```

15) Using the AXED40 Infra-red Upgrade

The optional infra-red upgrade (part AXED40) allows the micro-robot to be remote controlled from a TV style remote control. An infra-red sensor (LED020) is soldered onto the micro-robot control PCB

Please note the standard PICAXE-18 chip supplied on the micro-robot control board must be upgraded to a PICAXE-18A or PICAXE-18X chip to use this upgrade.

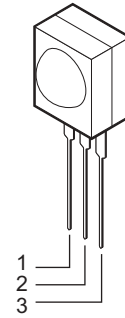

AXED40 Contents:

- Infra-red remote transmitter (part TVR010)*
 - Infra-red remote control receiver (part LED020)
 - 4.7uF capacitor
 - 2 resistors (not required as micro-robot already has these pre-fitted to control PCB)
- *requires 3x AAA batteries (not supplied)

Assembly:

- 1) Remove control PCB from top of the micro-robot.
- 2) Solder the remote control receiver in position IR, curved side facing forwards. It is recommended that the sensor is left on 'long' legs so it is above other parts.
- 3) Solder the 4.7uF capacitor in position C6, making sure the long +ve leg is correctly aligned.
- 4) Replace control PCB on top of micro-robot.
- 5) Program the transmitter with code C-2-1-2 (see below)

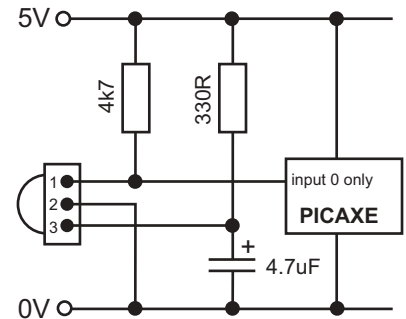

Programming the transmitter.

Before use (or after battery change) the transmitter must be programmed as follows:

1. Insert 3 AAA size batteries, preferably alkaline.
2. Press 'C'. The LED should light.
3. Press '2'. The LED should flash.
4. Press '1'. The LED should flash.
5. Press '2'. The LED should flash and then go out.

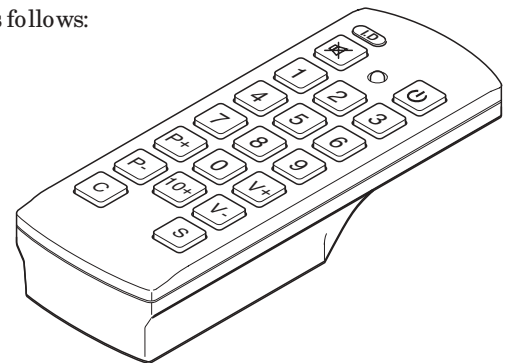

Sample Program.

A sample program to provide remote-control of the micro-robot.

```

main: pause 100
lp1:  infrain    'wait for new signal
      if infra = 2 then go_f 'forward
      if infra = 8 then go_b 'backward
      if infra = 6 then go_r 'right
      if infra = 4 then go_l 'left
      if infra = 5 then go_s 'stop
      goto lp1

go_f: let pins = %10100000
      goto lp1
go_b: let pins = %01010000
      goto lp1
      (cont...)
go_l: let pins = %10010000
      goto lp1
go_r: let pins = %01100000
      goto lp1
go_s: let pins = %00000000
      goto lp1
      (cont...)
    
```